

A Guide to Setting Up Your Classroom Aquarium

...for Hatching and raising salmonids



**using an undergravel filter
with an Airlift System**



Setting Up a Classroom Aquarium

This booklet is intended as a guide for teachers who want to hatch trout, steelhead or salmon in their classroom. All three species are salmonids and require pretty much the same conditions to survive. There are many methods which have proven successful in hatching and raising fish, the following are based on my experiences hatching and raising fish for over 40 years and participating in Trout in the Classroom for 9 years.

*...Ed Huff
Mission Peak
Fly Anglers*

Equipment:

Aquarium - A 10 gallon aquarium is recommended. Other sizes will work but this size has proven to be a good compromise between cost and reliability. It is recommended that you do not use an aquarium smaller than 10 gallons because larger aquariums provide a more stable environment. Aquariums larger than 10 gallons require correspondingly larger chillers and chillers are a significant part of the initial set-up cost.

Insulating Jacket - Trout and salmon fry require cool water so an insulating jacket must be provided to prevent heat loss. Fabrication of the insulating jacket is not covered in this guide. The commonly used material is polystyrene foam (Styrofoam) sheets, cut to fit around all 4 sides and the top and bottom of the aquarium. Notches will need to be cut in the rear of the jacket to clear airline tubing and the probe. The top will need a notch to clear the chiller and provide adequate air circulation. The front panel is generally hinged to allow viewing access and the top is removable to allow for maintenance.

Filtration/Aeration - There are many systems available to provide circulation, filtration and aeration in the aquarium. The most commonly used systems in our program employ under-gravel filter plates combined with a method to circulate the water throughout the aquarium. These systems operate by drawing water down through the gravel and into a space under the gravel that is provided by the installation of filter plates. The water is then drawn up through filter riser tube(s) and back into the aquarium. The lift is provided by an airlift system comprised of air stones and an external air pump (refer to the illustrations on page 3). The primary job of this system is to provide circulation for the even distribution of oxygen and temperature. (The creation of a natural biological filtration cycle takes longer than the program will be active. The fish will be released before any meaningful populations of nitrifying bacteria are established.)

Substrate - Although hatchery reared trout or salmon are not placed in gravel, gravel is used in the classroom situation to provide a more natural appearing environment for the students. When selecting gravel, water worn river gravel is a good choice. It has smooth edges and is generally inert. A good source for this gravel is aquarium shops. Some teachers are experimenting with white gravel. It doesn't look as natural, but it makes the eggs more visible. A good rule of thumb is 2 pounds of gravel for each gallon of water. This will provide sufficient depth for the filter system.

Chiller - Some method must be provided to keep the aquarium cool. There are several systems available and which manufacturer you choose is not as important as ensuring the chiller is capable of meeting the necessary requirements. Typical aquarium temperatures in classroom situations run from the mid 50's to the low 60's. Your target temperature should be around 55° F (13° C), 24 hours a day. Remember, these animals are coldblooded and their metabolism speeds up as the temperature goes up. This means that at higher temperatures, they will spend less time in their various life stages. Your sponsor will be able help you choose the best chiller for your situation. The chiller covered in this guide is the "Ice Probe" manufactured by Nova Tec. The *Ice Probe* is a thermoelectric chiller capable of pulling down an insulated aquarium 20 degrees below ambient.

Water - Generally, there are two sources for water: bottled spring water and tap water. Bottled spring water is the most often used water source. It is commonly available in 2.5 gallon containers and can be used as is. Do not use de-ionized or distilled water, as these do not contain elements that are required by your fish. If you elect to use tap water, it must be treated to remove chemicals that have been added to destroy bacteria. Chlorine has traditionally been used to purify



drinking water and is easily removed by aeration and/or the use of de-chlorinators (sodium thiosulfate) available from pet stores. Many public utilities are switching to the use of chloramines. Chloramines are a combination of ammonia and chlorine and are much more stable than chlorine alone. Aeration and/or the use of de-chlorinators are not effective on chloramines. You must use a product intended for use on chloramines. These are available at your local aquarium store.

Additional Equipment – In addition to the equipment listed on page 1, you will also need a few other items to complete setting up the aquarium and monitoring the system:

Airline tubing: flexible airline tubing is available in all aquarium shops and some hardware stores. Most aquarium systems use 3/16 inch diameter clear vinyl tubing. You will need 4 feet or more depending on where you locate the air pump.

Airstones: If they are not provided with the filter, you will need 2 airstones. They are available at all pet stores that sell tropical fish.

2-gang air valve: you will need this valve to distribute the air to 2 airstones. They are available at all pet stores that sell tropical fish.

Thermometer: there are generally two versions available in the aquarium trade; a simple alcohol-based unit using a small glass tube mounted on an aluminum base and a digital unit with a probe. The alcohol-based thermometers are inexpensive but hard to read and not particularly accurate. The digital ones are more expensive but easier to read in both Fahrenheit and Celsius and they are more accurate.

Turkey baster: a baster is necessary to gently remove any unwanted debris and dead eggs without disturbing the developing fish. Purchase a plastic one rather than a glass one, you may have to enlarge the tip to allow the unwanted eggs to pass through.

Siphon tube: a siphon tube will be needed if you wish to change the water or drain the aquarium prior to release. A 48 inch length of 5/8 inch inside diameter clear vinyl tubing will work fine. If you can locate a 12 inch length of 5/8 inch diameter rigid plastic tubing to slip into the end of the vinyl tubing it will make the siphon much easier to use.

Net: a small aquarium net, a 3 inch size works well.

Cleaning the Aquarium and Equipment

Proper cleaning of the aquarium and any related equipment is necessary to prevent fish losses due to toxicity, disease and parasites. A fish's relationship to its environment is much closer than it is for land dwelling animals. Pollutants such as residual cleaning solutions, decomposing plant or animal matter as well as disease organisms could all cause the early demise of your fish. Removal of these elements is relatively simple if you follow a few guidelines. Thoroughly rinse all equipment that will come in contact with water during the hatching and rearing process. Use straight tap water, do not use soaps or detergents. Wash your hands carefully before you begin, removing all residual soap, hand creams or perfumes.

Cleaning agents are a common cause of fish deaths. When collecting buckets and other paraphernalia to use for cleaning the aquarium do not use any that have been previously used with cleaning solutions. Even trace amounts can stress or kill fish.

After assembling all of the equipment, place those to be washed in your clean bucket and rinse thoroughly. After the equipment is washed place the gravel in the bucket and fill with tap water. Using your hands, reach in and stir the gravel to loosen dirt and debris. Pour the cloudy water off the top being careful not to lose any gravel. Repeat this process until the water runs clear.

If you feel you have had problems with aquatic parasites in the past, the best solution to prevent contaminated equipment from re-infecting the fish is to rinse all items thoroughly and dry them **completely**. Aquatic parasites cannot survive a dry environment.

If you need to sterilize the gravel here are two methods:

A bath in a mild chlorine solution. The solution is prepared by adding 1 part household bleach to 10 parts water (1 cup of bleach to 10 cups of water). You should wear protective eyewear and disposable gloves and beware of splashes. Let the gravel soak for at least 30 minutes. Rinse thoroughly in fresh water and, if possible, allow to dry. If there is no time to dry the rinsed gravel, fill the aquarium and add a de-chlorinator (available at your local pet shop) at the suggested dosage.

Boiling the gravel. Place the gravel in a suitable container, cover with water and boil for at least 15 to 20 minutes, allowing it to cool before use.



Setting Up the Aquarium

Make sure all the components have been thoroughly cleaned and rinsed.

Start by selecting a suitable location: The aquarium should not be near a strong light or heat source (such as a window), it should be located for easy access by the students, it needs to be near an electrical outlet (that is on 24 hours a day) and it must be placed on a sturdy table or shelf. Make sure your selected location is flat and able to support at least 100 pounds (water is heavy, it weighs 8.3 pounds per gallon).

Before you add anything to to aquarium, slide the empty aquarium into the foam insulating jacket and place it in the location you have selected.

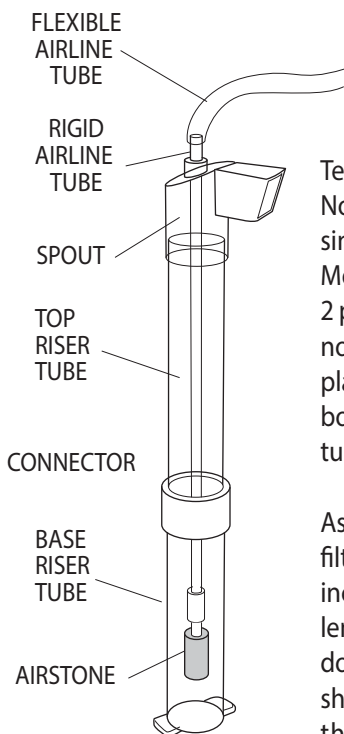
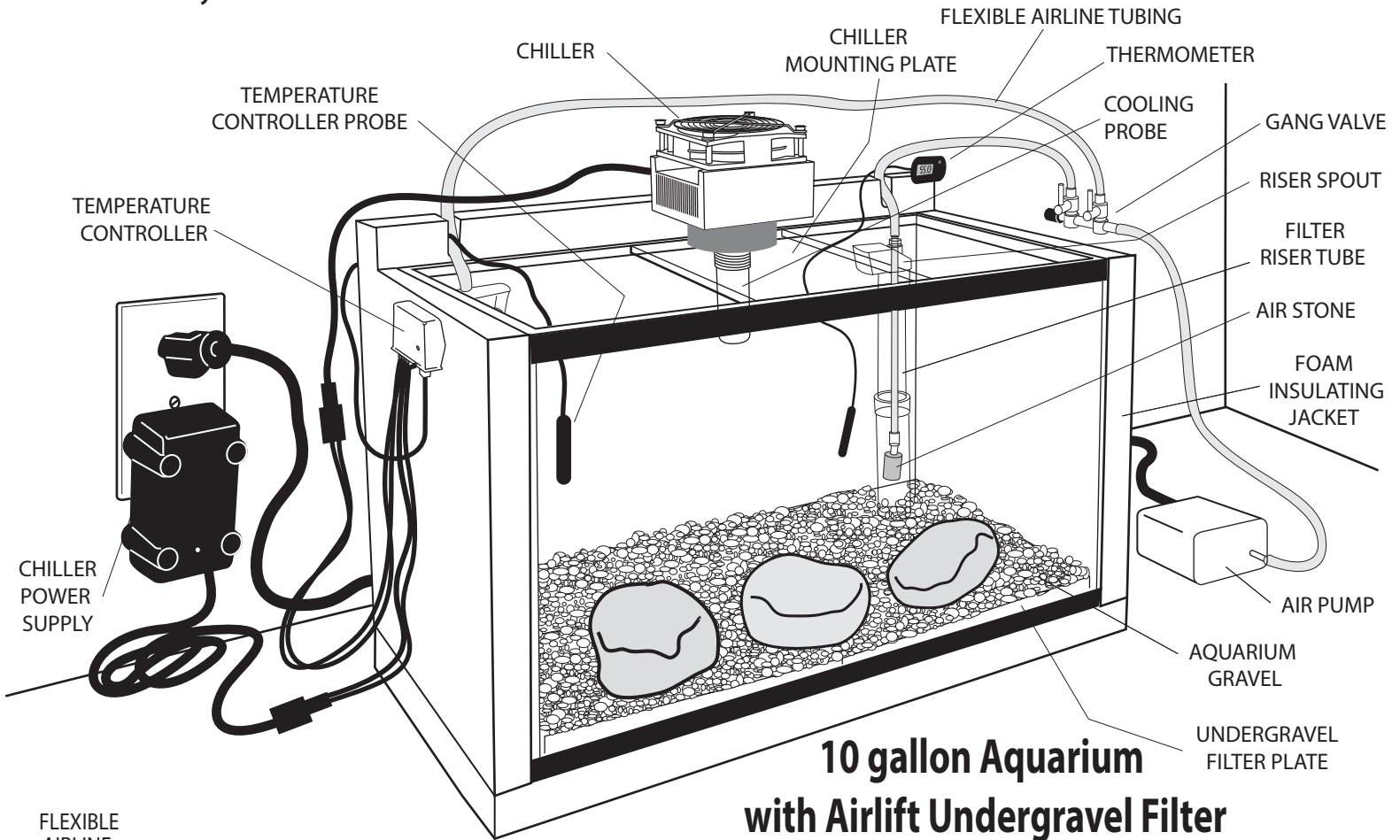

Installing the Filter

Ten gallon aquariums generally use 2 filter plates. Normally the 2 plates are joined together to form a single plate that covers the bottom of the aquarium. Most suppliers supply clips that you can use to hold the 2 plates together. For our purposes joining the 2 plates is not critical and the system will function fine as separate plates. Place the individual or joined plates in the bottom of the aquarium with the sockets for the riser tubes in the back.

Assemble the riser tubes before inserting them into the filter plates. Begin by installing the airstones. Attach 18 inch lengths of flexible airline tubing to two 9 inch lengths of rigid airline tubing. Thread the rigid tubing down through the top of each riser tube spout. Using a short length of flexible tubing, attach the rigid tubes to the airstones and slide the assembled spouts with



airstones onto the top riser tubes. Slide each of the top riser tubes through the connectors and into the base tubes. Now insert each tube assembly into its location on the back corners of the filter plates (see illustration). Adjust the airline tubing so that the airstones are near the bottom. Rotate the spouts so that they will direct the water flow towards the chiller.

Locate a 2-gang air valve in a convenient location (usually somewhere along the back of the aquarium). Connect each of the airlines coming out of the riser tubes to the outlet sides of each of the valves (see the illustration on the previous page). Place the air pump in a convenient location and cut a piece of airline tubing to connect from the air pump to the inlet side of the gang valve. You may have to cut some small notches in the rear side of the foam jacket to allow the airline tubing to pass from the top of the riser tubes, under the top and out to the gang valve.

To help prevent the alevins from burrowing under the gravel and ending up under the filter plates I recommend you add some fiberglass window screen (**do not use aluminum screen**). To add the window screen pick up some common fiberglass window screen from the hardware store. Trim the screen so that it is approximately $\frac{1}{2}$ inch larger than the inside dimensions of your aquarium and cut notches in the back corners to clear the two lift tubes. Normal household scissors work well for this operation. Lay the screen on top of the filter plates and arrange it so that it rides slightly up all four sides of the aquarium.



Adding the Gravel



Begin adding the gravel in the center of the aquarium. This will hold the screen in place while you add the rest of the gravel. After adding the rest of the gravel, spread it out towards the edges. Level the gravel out, sloping it from back to front. Making the back slightly higher than the front will help keep the eggs near the front where the students can observe them. After the fry are up and swimming the slope will concentrate any unwanted debris towards the front of the aquarium where it can be siphoned up.

Many teachers add large stones to create a more natural appearing environment. Arrange the stones near the front of the aquarium. Since the alevins often try to hide under the stones, keeping the stones near the front of the aquarium will make the alevins easier to see. Use smooth, hard stones and avoid porous stones or those with many cavities. As with everything else, rinse thoroughly.

Adding the Water

Adjusting the aquarium's temperature later on will be much simpler if you start with water that is close to the desired temperature of around 55° F. Storing your water supply outside prior to use is a good way to start with cooler water. If you are using bottled spring water from 2.5 gallon containers, it is easier if you remove the valve body from the container before you begin. Place the container on the floor with the valve facing up. If you grasp the inner part of the valve and pull out past the stop the whole assembly will come out, greatly improving the flow. Punch a small vent hole in the top corner to also improve flow. If you are using tap water, add the water treatment at this time at the manufacturers recommended dose. To prevent the water from disturbing the gravel while filling, place a clean saucer in the bottom of the aquarium and pour into the center of it. The water should be added until the level is even with the bottom edge of the aquarium's top frame. This level should be maintained throughout the hatching and raising process. This is especially important if you are using Nova Tec's chiller as the cooling probe needs to be as deeply immersed as possible to maintain its efficiency.

Installing the Chiller

A plastic plate of ¼ inch thick Plexiglas, or similar material, should be cut 6 inches wide and the proper length to fit snugly on the ledge inside the frame of the aquarium. A 1¼ inch hole is cut into the plate to allow the chiller's cooling probe to enter the water. Install the chiller on the plate by inserting the probe into the plate and, using the nut provided, attach it securely. Rotate the chiller so that the power cord faces to the rear. Center the plastic plate holding the chiller and set it between the aquarium's frame. The chiller cools by removing heat from the water and dissipating it via the unit's fan and finned heat sink. When you add the foam top remember that the cooling fins and fan on the top of the chiller need adequate clearance to allow for proper heat dissipation. Attach the chiller power cord plug to the temperature controller and the temperature controller plug to the power supply (see illustration on page 3). The plugs are keyed and will only fit one way. Install a thermometer. If your budget allows it, the digital thermometers seem to be more accurate and are much easier to read.

After the chiller is installed, start the air pump, open both valves fully and adjust the air flow. Do this by turning down one or both of the valves on the gang-valve until the flow of bubbles in each filter tube is approximately equal. Let everything run for ten minutes or more to stabilize before beginning to adjust the chiller's temperature controller.

Adjusting the Temperature Controller

If possible, try to get the aquarium water near to the desired temperature before attempting to adjust the chiller. Leaving the water containers outside prior to using them is one way to start with cool water. You can also lower the temperature by floating some water bottles that have been frozen. To prepare these bottles start by washing them thoroughly and filling them with tap water. Leave a little air space at the top to allow for the ice to expand and place them in a freezer. When frozen, place them in the aquarium. Use your thermometer to measure the temperature. Plug the chiller's power supply into a suitable electrical outlet. The fan will begin to run (it is designed to run continuously). If the green light comes on, rotate the adjusting screw on the temperature controller counterclockwise until the light on the chiller just goes out (see illustration). Use a miniature screwdriver to make adjustments to the controller. If the thermometer indicates the desired temperature, turn the adjusting screw until the light just goes on and you're set. If the temperature is too warm, turn the adjusting screw another quarter turn counterclockwise. Wait until the chiller has cooled the water further and either the light goes out or the desired temperature has been reached (this can take up to 24 hours). Check the temperature, if it is still too warm turn the adjustment screw another quarter turn. You have to continue this procedure until the desired temperature is reached. If, when the desired temperature is reached, the green light is still on, turn it clockwise until the light just goes out, then carefully turn it counterclockwise until it just comes back on. This can be a pretty slow process. It is much faster to use frozen water bottles to move things along. This is another reason to begin setting up the aquarium a week or more prior to the arrival of the eggs

NOTE: On some models of the temperature controller, the temperature adjusting screw is located on the bottom.!

NOTE: It is a good idea to tag your electrical cords asking the janitor or others not to disconnect the power to the aquarium.



Storing the Aquarium and Equipment

There are two primary rules to follow to prepare everything for storage: thoroughly rinse everything and thoroughly dry everything. Gravel should be rinsed in a bucket as you did when setting up the aquarium and then spread out on a plastic sheet and allowed to dry. After it is dry store it in a cloth or mesh bag that will allow the gravel to breathe.

For more help and information go to: www.wildlife.ca.gov and click on Classroom Aquarium Education Program

