



# APPENDIX A

---

## Scoping Report



*This page intentionally left blank*

# **BALLONA WETLANDS RESTORATION PROJECT SCOPING REPORT**

## **PREPARED FOR:**

California Department of Fish and Wildlife  
Region 5  
3888 Ruffin Road  
San Diego, CA 92123  
Contact: David Lawhead  
858-627-3997

and

Los Angeles & San Bernardino Counties Section  
U.S. Army Corps of Engineers  
Regulatory Division  
915 Wilshire Blvd.  
Los Angeles, CA 90017

## **PREPARED BY:**

ICF International  
1 Ada, Suite 100  
Irvine, CA 92618  
Contact: Donna McCormick  
949-333-6600

**January 2014**



ICF International. 2014. Ballona Wetlands Restoration Project Scoping Report. January. (ICF Project #658.09.) Irvine, CA. Prepared for California Department of Fish and Wildlife, San Diego, CA and U.S. Army Corps of Engineers, Los Angeles, CA.



# Ballona Wetlands Restoration Project Scoping Report

---

## 1.0 Introduction

This report summarizes the public involvement activities implemented during the scoping phase of the environmental review process for the Ballona Wetlands Restoration Project. The **California Department of Fish and Wildlife (CDFW)**<sup>1</sup> and the U.S. Army Corps of Engineers (USACE) are jointly preparing an Environmental Impact Report/ Environmental Impact Statement (EIR/EIS) for the Ballona Wetlands Restoration Project. Public input on the Ballona Wetlands Restoration Project was sought during the scoping process to help identify alternatives and issues to be addressed in the Draft EIR/EIS.

## 2.0 Scoping Period Outreach

At the state level, CDFW is the designated lead agency for the EIR because most of the Ballona Wetlands project site is owned by CDFW. At the federal level, USACE is designated lead agency for the EIS because the proposed action requires USACE approval of permits. The Ballona Wetlands Restoration Project will follow the dual track of both CEQA and NEPA as the environmental impacts of the project are assessed.

The basic purposes of CEQA and NEPA are to inform governmental decision makers and the public about the potential, significant environmental effects of proposed activities and identify the ways to mitigate the environmental impacts. The lead agencies are required to analyze the environmental impacts of the project and must also look to the impacts of reasonable alternatives, including a “no project alternative” (under CEQA) and a “no action alternative” (under NEPA).

Each process requires a public notice that a project is being considered—a Notice of Preparation (NOP) under CEQA and a Notice of Intent (NOI) under NEPA. CDFW and USACE released their NOP and NOI for public review in August 2012. Both documents can be viewed on the Ballona Wetlands Restoration Project website ([www.ballonarestoration.org](http://www.ballonarestoration.org)) and are available in Attachment A.

The scoping period was originally set at 30 days and scheduled to close on September 10, 2012; however, it was later extended to 60 days and ended on October 23, 2012.

---

<sup>1</sup> At the time, this agency was known as the California Department of Fish and Game (CDFG).



## 2.1 Noticing

The NOP was received by the State Clearinghouse and the Los Angeles County Recorder on July 27, 2013. The NOI was published in the Federal Register on July 25, 2012. Copies of the notices are available in Attachment A.

## 2.2 Advertising

An advertisement announcing the public scoping meeting was placed in *The Argonaut* on August 2, 2012. A copy of the advertisement is available in Attachment B.

## 2.3 Scoping Meeting

CDFW and USACE held a joint public scoping meeting for both the NOP and NOI on Thursday, August 16, 2012 from 4:00 to 7:00 p.m. The meeting took place at the Fiji Gateway entrance to the Ballona Wetlands at 13720 Fiji Way, Marina del Rey, CA 90292. Various materials were available for public review at the scoping meeting, including handouts, comment cards, and presentation boards on easels. Representatives from CDFW and USACE attended the meeting, as well as staff from the California Coastal Conservancy and the Santa Monica Bay Restoration Commission, who are sponsoring the project, and their consultant team.

## 2.4 Commenters

A summary of commenters who submitted letters, emails, and comment cards on the NOP and NOI during the scoping period is presented in Table 1. Copies of comments submitted at the public scoping meeting and during the scoping period are available in Attachment C.

**Table 1. Summary of Commenters**

Date	Agency/ Organization	Commenter	Format
Scoping Comments Received at the Scoping Meeting			
8/16/2012		Eric Andres	Comment card
8/16/2012		Fran Bibian	Comment card
8/16/2012		Fran Bibian	Comment card
8/16/2012		Ellen Brennan	Letter delivered at scoping meeting
8/16/2012		Carolyn Glassman	Comment card
8/16/2012		Carolyn Glassman	Comment card
8/16/2012		Adam Kliszewski	Comment card
8/16/2012		Michael Lutz	Comment card
8/16/2012		Ingrid Moeller	Comment card
8/16/2012		Elizabeth Pollock	Comment card
8/16/2012		Al Sattler	Comment card
8/16/2012		DeAna Vitela-Hayashi	Business card left at scoping meeting
8/16/2012	Grassroots Coalition	Patricia McPherson	Copies of emails and letters left at scoping meeting
8/16/2012	Sierra Club	Joe Young	Letter left at scoping meeting



<b>Date</b>	<b>Agency/ Organization</b>	<b>Commenter</b>	<b>Format</b>
<b>Scoping Comments Received during the Comment Period</b>			
7/31/2012		Janice Hahn	Letter to Jo-Ellen Darcy, U.S. Army
8/2/2012	Native American Heritage Commission	Dave Singleton	Letter to David Lawhead, CDFW
8/2/2012		William Ballough	Email to Daniel Swenson, USACE
8/3/2012		Howard Hackett	Email to Donna McCormick, ICF
8/7/2012		Anita Gutierrez	Email to Donna McCormick, ICF
8/13/2012		Susan Herrschaft	Email to Daniel Swenson, USACE
8/13/2012		Colleen Phillips	Email to Elena Tuttle, SMBRF
8/13/2012	Vista del Mar Neighbors Association of Playa del Rey	Julie Inouye and Dr. Michael Rubottom	Email to Donna McCormick, ICF and Shelley Luce, Santa Monica Bay Restoration Commission
8/14/2012		Cynthia Cannady	Email to Donna McCormick, ICF
8/14/2012		Lisa de Vincent	Email to Donna McCormick, ICF
8/14/2012		Art Lee	Email to Donna McCormick, ICF
8/14/2012		Colleen Phillips	Email to Donna McCormick, ICF
8/14/2012		Karen Thiers	Email to Donna McCormick, ICF
8/14/2012		Ashley Wilson	Email to Donna McCormick, ICF
8/16/2012		Carolyn Anderson	Email to Donna McCormick, ICF
8/16/2012		Christopher McKinnon	Email to Donna McCormick, ICF
8/16/2012		Lucien Plauzoles	Email to Donna McCormick, ICF
8/16/2012	Grassroots Coalition	Patricia McPherson	Email to Donna McCormick, ICF
8/16/2012	Sierra Club	Joe Young	Letter to Daniel Swenson, USACE and David Lawhead, CDFW
8/18/2012		Mary Prismon	Email to Donna McCormick, ICF
8/19/2012		April de Stefano	Email to Donna McCormick, ICF
8/20/2012		Barbara Yang	Email to Donna McCormick, ICF
8/21/2012	California Cultural Resource Preservation Alliance, Inc.	Patricia Martz	Letter to Daniel Swenson, USACE
8/21/2012		Rosie Puntillo	Email to Donna McCormick, ICF
8/24/2012	Department of Conservation	Syndi Pompa	Letter to Donna McCormick, ICF
8/24/2012		Walter Lamb	Email to Donna McCormick, ICF
8/29/2012		Fernanda Braga	Email to Donna McCormick, ICF
8/29/2012		Eddie Chan	Email to Donna McCormick, ICF
8/29/2012		Alana & Michael Getz	Email to Donna McCormick, ICF



<b>Date</b>	<b>Agency/ Organization</b>	<b>Commenter</b>	<b>Format</b>
8/29/2012		Barsam Kasravi	Email to Donna McCormick, ICF
8/29/2012		Julie Thomas Knap	Email to Donna McCormick, ICF
8/29/2012		Tanya & Todd Leeloy	Email to Donna McCormick, ICF
8/29/2012		Kevin Lohman	Email to Donna McCormick, ICF
8/29/2012		Ulrik Knap	Email to Donna McCormick, ICF
9/4/2012		Nikol Lohman	Email to Donna McCormick, ICF
9/4/2012		Liesbeth Maggiotto	Email to Donna McCormick, ICF
9/4/2012		Erin Mays	Email to Donna McCormick, ICF
9/9/2012		Tanya Lindsley	Email to Donna McCormick, ICF
9/10/2012		Ruben Cruz	Email to Daniel Swenson, USACE
9/10/2012	Marina del Rey Convention & Visitors Bureau	Bev Moore	Email to Donna McCormick, ICF
9/21/2012		Liisa Bishop	Email to Donna McCormick, ICF
9/26/2012		Bruce Schelden	Comment Card
9/26/2012		Lew Weinfeld	Email to Donna McCormick, ICF
10/4/2012		Alice Goldstein	Email to Donna McCormick, ICF
10/8/2012		Allen Frankel	Letter to David Lawhead, CDFW and Terri Steward, CDFW
10/13/2012		Hawley Almstedt	Email to Donna McCormick, ICF
10/14/2012		Rosemarie Kornarens	Email to Donna McCormick, ICF
10/15/2012	Los Angeles Audubon	Travis Longcore	Letter to Daniel Swenson, USACE
10/17/2012		Sandra Glass	Email to Donna McCormick, ICF
10/18/2012		Louise Steiner	Letter to Daniel Swenson, USACE
10/29/2012		Louise Steiner	Letter to David Lawhead, CDFW and Terri Steward, CDFW
10/20/2012		Douglas Fay	Email to Daniel Swenson, USACE
10/20/2012		Sue Sass	Email to Charles Piechowski, SMBRF
10/21/2012		Donna Murray	Letter to David Lawhead, CDFW and Terri Steward, CDFW
10/21/2012		Rick Pine	Email to Donna McCormick, ICF
10/22/2012		Stephanie Beckmar	Comment card
10/22/2012		Michele Bigelow	Email to Donna McCormick, ICF
10/22/2012		Joe Cadwallader	Email to Donna McCormick, ICF
10/22/2012		Molly Curtis	Comment card
10/22/2012		Scott Garvey	Email to Donna McCormick, ICF; Daniel Swenson, USACE; and David Lawhead, CDFW
10/22/2012		Lauren Gottlieb	Letter to Daniel Swenson, USACE; David Lawhead, CDFW; and Terri Stewart, CDFW
10/22/2012		Cindy Grant	Comment card





<b>Date</b>	<b>Agency/ Organization</b>	<b>Commenter</b>	<b>Format</b>
10/22/2012		Steffi Jones	Email to Donna McCormick, ICF
10/22/2012		Travis Longcore	Email to Donna McCormick, ICF
10/22/2012		Donna Murray	Email to Donna McCormick, ICF
10/22/2012		Susan Roughen	Comment card
10/22/2012	Friends of Ballona	David Kay	Email to Donna McCormick, ICF and Daniel Swenson, USACE
10/22/2012	Grassroots Coalition	Patricia McPherson	Email to Daniel Swenson, USACE and David Lawhead, CDFW
10/23/2012	U.S. Fish and Wildlife Service	Jonathan Snyder	Email to Daniel Swenson, USACE
10/23/2012		Michele Bigelow	Email to Donna McCormick, ICF
10/23/2012		Bruce Campbell	Email to Donna McCormick, ICF; Daniel Swenson, USACE; and David Lawhead, CDFW
10/23/2012		Natalie Carrere	Email to Donna McCormick, ICF
10/23/2012		Mike Chamness	Email to Donna McCormick, ICF; Daniel Swenson, USACE; and David Lawhead, CDFW
10/23/2012		Joyce Dillard	Email to Daniel Swenson, USACE
10/23/2012		Douglas Fay	Email to David Lawhead, CDFW and Daniel Swenson, USACE
10/23/2012		Margot Griswold	Email to Donna McCormick, ICF; Daniel Swenson, USACE; and David Lawhead, CDFW
10/23/2012		Susan Herrschaft	Email to Donna McCormick, ICF; Daniel Swenson, USACE; and David Lawhead, CDFW
10/23/2012		Mary Knight	Email to David Lawhead, CDFW and Daniel Swenson, USACE
10/23/2012		Jim Lamm	Email to Donna McCormick, ICF
10/23/2012		Keith Linker	Email to Donna McCormick, ICF
10/23/2012		Barbara Lonsdale	Email to Donna McCormick, ICF; Daniel Swenson, USACE; and David Lawhead, CDFW
10/23/2012		Ramona Merryman	Email to Donna McCormick, ICF; Daniel Swenson, USACE; and David Lawhead, CDFW
10/23/2012		Anita Miller	Comment card
10/23/2012		Cliff Moser	Email to Donna McCormick, ICF
10/23/2012		Jack Neff	Email to Donna McCormick, ICF; Daniel Swenson, USACE; and David Lawhead, CDFW
10/23/2012		Leslie Purcell	Email to Donna McCormick, ICF; Daniel Swenson, USACE; and David Lawhead, CDFW
10/23/2012		Kerry Rasmussen	Email to Donna McCormick, ICF
10/23/2012		Gary Stickel	Email to Donna McCormick, ICF; Daniel Swenson, USACE; and David Lawhead, CDFW
10/23/2012		Lola Verdurer Terrell	Email to Donna McCormick, ICF
10/23/2012		John Ulloth	Email to Donna McCormick, ICF; Daniel Swenson, USACE; and David Lawhead, CDFW



<b>Date</b>	<b>Agency/ Organization</b>	<b>Commenter</b>	<b>Format</b>
10/23/2012	Ballona Institute & Wetlands Defense Fund	Marcia Hanscom and Robert Roy van de Hoek	Letter to Daniel Swenson, USACE; David Lawhead, CDFW; and Donna McCormick, ICF
10/23/2012	Ballona Wetlands Land Trust	Walter Lamb	Email to Donna McCormick, ICF; Daniel Swenson, USACE; and David Lawhead, CDFW
10/23/2012	Ballona Ecosystem Education Project	Rex Frankel	Email to Donna McCormick, ICF and Daniel Swenson, USACE
10/23/2012	Ballona Ecosystem Education Project	Rex Frankel	Email to Donna McCormick, ICF and Daniel Swenson, USACE
10/23/2012	Heal the Bay	Katherine Pease	Email to Donna McCormick, ICF
10/23/2012	Sierra Club	Marcia Hanscom	Letter to Daniel Swenson, USACE; David Lawhead, CDFW; and Donna McCormick, ICF
10/23/2012	Southern California Gas Company	Anthony Klecha	Email to Daniel Swenson, USACE
10/23/2012	California Native American Heritage Commission	Dave Singleton	Email to Donna McCormick, ICF
<b>Scoping Comments Received After the Deadline</b>			
10/24/2012		Westley Eftekhari	Email to Donna McCormick, ICF
10/24/2012		Donald Owens	Comment card
10/24/2012	Grassroots Coalition	Patricia McPherson	Email to Daniel Swenson, USACE and David Lawhead, CDFW
10/25/2012		David Jacobs	Email to Donna McCormick, ICF
11/13/2012		Kathy Knight	Email to Daniel Swenson, USACE and David Lawhead, CDFW
11/17/2012		Cliff Moser	Email to Donna McCormick, ICF
11/1/2013	Grassroots Coalition	Patricia McPherson	Letter to Colonel Kimberly Colloton
<b>Scoping Comments Follow Up</b>			
10/25/2012	Native American Heritage Commission	David Singleton	Email to David Lawhead, CDFW



## 2.5 Comments Received

A summary of comments received during the scoping period is presented in Table 2. This list is sorted by the chapters or sections of the EIR/EIS where the comment topics will be addressed. Copies of comments submitted at the public scoping meeting and during the scoping period are available in Attachment C.

**Table 2. Summary of Comments Received during the NOP/NOI Scoping Period**

Resource	Comment Summary
General/Overall	<ul style="list-style-type: none"> <li>• Consider impacts/mitigation for maintenance activities; assign responsibilities for mitigation.</li> </ul>
1.0 Introduction	<ul style="list-style-type: none"> <li>• Identify lead agencies and other agencies/parties involved.</li> <li>• Provide history of Ballona Wetlands (previous tidal influence)/substantiate claim of previous tidal influence/support historic justification.</li> </ul>
2.0 Purpose and Need/Goals and Objectives	<ul style="list-style-type: none"> <li>• How was the goal of estuarine habitat established?</li> <li>• What is the purpose and need?</li> <li>• Discuss objectives related to end-of-pipe pollutions treatment, flood protection, mitigation for other projects (LA Port), and date to which restoration is being targeted.</li> <li>• What is the purpose of relocating Ballona Creek?</li> <li>• Protection of groundwater and groundwater wells.</li> <li>• Address Congressional house document 389 and US Public Law 780.</li> <li>• Presence of non-permitted drains put in by and for Playa Vista.</li> <li>• Need to substantiate the claim that the Reserve has witnessed hydrological degradation.</li> <li>• Ballona is predominantly a seasonal freshwater system that did not perform with a daily ebb and flow of tidal waters.</li> </ul>
3.0 Project Description and Alternatives	<ul style="list-style-type: none"> <li>• Comments requested consideration of various complete alternatives.               <ul style="list-style-type: none"> <li>○ Ballona Wetlands Education Project (BEEP) alternative.</li> <li>○ Friends of Ballona Wetlands conceptual plan.</li> <li>○ “Process oriented historical treatment” alternative.                   <ul style="list-style-type: none"> <li>▪ Focus on heterogeneous brackish to fresh and seasonally variable habitats.</li> <li>▪ Specifically address recovery of taxa that were historically present and are now special-status.</li> <li>▪ Replicate processes such as scour.</li> <li>▪ Maintain beneficial artificial processes such as sediment expulsion and contaminant bypass by flood control channel.</li> <li>▪ Do not unduly penetrate freshwater and riparian areas with new drainage channels.</li> <li>▪ Work with existing landscape to mitigate ancillary impacts and undo earth movement; coordinate with necessary infrastructure enhancement and roadwork.</li> <li>▪ Retain flood tidal channel and levees to expel sediment from system; bypass contaminants during first flush; provide flood protection; use tide gates if needed in response to sea-level rise.</li> <li>▪ Use multiple gates (multiple inflow, single outflow) and drop to flood channel to provide scour to lateral marsh channels—</li> </ul> </li> </ul> </li> </ul>



Resource	Comment Summary
	<p>minimize velocity and sediment import on incoming tide; allow bypass of first-flush contaminants; general scouring flow by manipulating gates.</p> <ul style="list-style-type: none"> <li>▪ Replicate seasonal wetland dynamics through gates or closures.</li> <li>▪ Use existing raised roadbeds as partitions for habitat management.</li> <li>▪ Area B                             <ul style="list-style-type: none"> <li>• Surround/support existing freshwater wetland with seasonally variable wetlands.</li> <li>• Integrate tidal operation of North Area B with existing flood control channel.</li> <li>• Avoid draining areas with freshwater resources/potential, with tidal/drainage channels.</li> <li>• Manage Area B south of Culver as winter wet seasonal or intermittent freshwater to brackish wetland with reduction of current channels, using freshwater marsh to generate seasonal hydrology (using existing spillway).</li> <li>• Provide greater connection to flood control channel in Area B north of Culver by additional upstream tide gate, designed and operated to generate scour near openings to channel and integrate Ballona Creek tidal function as appropriate; remove roadbeds and oil field structures to facilitate surface flow penetration of spring tides; operate to maximize penetration of high tide and support seasonal perched water; enhance brackish conditions.</li> <li>• Raise Culver to accommodate higher water and protect against sea-level rise and tsunamis, including spans to permit integration and communication between wetland areas.</li> <li>• Use area between Culver and Jefferson as summer-closed habitat with intermittent openings to tides in winter through gate or valve; sustain endangered tidewater gobies; source freshwater from adjacent freshwater marsh; use gate or valve to channel to generate tidal conditions.</li> </ul> </li> <li>▪ Area C                             <ul style="list-style-type: none"> <li>• Recover freshwater flow from Ballona channel to generate range of intermittent fresh to brackish environments with flow through to Area A.</li> <li>• Convey Ballona Creek water in low area immediately west of 90 and south of Culver; transport by gates or pumps to Area C north of Culver.</li> <li>• Area C north of Culver—replicate perched/flood deeper water (1 meter) condition in winter for waterfowl; drawdown in spring to provide foraging for least tern; use fill to raise portions of adjacent Culver and Lincoln.</li> <li>• Convey fresh/brackish water outflow to Area A by culvert under raised span on Lincoln to functionally connect Area A and C.</li> </ul> </li> <li>▪ Area A                             <ul style="list-style-type: none"> <li>• Gates or connections to Area C, flood control channel, Marina, to interconnect wet landscape.</li> <li>• Brackish water flow from Area C permits variable</li> </ul> </li> </ul>



Resource	Comment Summary
	<p>salinity/intermittent brackish conditions.</p> <ul style="list-style-type: none"> <li>• Gates to permit muting tides and scour management.</li> <li>• Varying amounts of upland.</li> <li>• Gates to flood channel and marina permit scour and closure; import water from Area C; allows alternation of tidal and perched brackish conditions.</li> <li>• Perched or muted conditions seasonally permit isolation of muted tide high marsh suitable for clapper rails reproduction in late spring.</li> <li>• Restoration following topography.</li> <li>• Prioritize restoration of lower north and east portions.</li> <li>• Maintain high ground adjacent to levees and around former oil field structures to southwest as upland.</li> </ul> <ul style="list-style-type: none"> <li>○ “No bulldozing” alternative.                     <ul style="list-style-type: none"> <li>▪ Small incremental changes.</li> <li>▪ Small changes to levees to permit more tidal access.</li> <li>▪ Removal nonnative plants.</li> <li>▪ Addition of perimeter bike path, viewing platforms, paths.</li> <li>▪ Preservation of uplands, dunes, salt pan.</li> <li>▪ Ability to enhance tidal hydrology.</li> <li>▪ Labor requirements.</li> <li>▪ Continued degradation.</li> <li>▪ Loss of social/economic/watershed values/services.</li> <li>▪ Ability to restore hydrologically functional restoration (recontouring, compaction to meeting engineering/construction standards).</li> <li>▪ Ability to be constructed with volunteer workers (qualifications, training, safety).</li> <li>▪ Completion timeline.</li> </ul> </li> <li>○ “Go slow” alternative.                     <ul style="list-style-type: none"> <li>▪ Slow down restoration.</li> <li>▪ Gradual, natural restoration, by hand, with small equipment, using students/community groups.</li> <li>▪ Experimental, over time; using community to grow plants and plant them.</li> </ul> </li> <li>○ Contiguous habitats.                     <ul style="list-style-type: none"> <li>▪ Raise Culver Boulevard instead of levees.</li> <li>▪ Relocate flood protection and roadways/utilities to outside edge (or raise out of flood zone on causeways to allow hydrologic continuity).</li> <li>▪ Raise Culver and Jefferson to allow water and animals to pass under.</li> <li>▪ Elevate Culver and Lincoln 3–4 meters to remove them from flood/tsunami hazard.</li> </ul> </li> <li>○ Lower cost/lower risk alternative.</li> <li>○ Acquire rather than restore alternative.                     <ul style="list-style-type: none"> <li>▪ North end of southern remnant of Ballona Lagoon in Playa del Rey.</li> <li>▪ Railway right-of-way adjacent to southwest edge of western end of 90 Freeway [Toyota dealership land].</li> </ul> </li> </ul>



Resource	Comment Summary
	<ul style="list-style-type: none"> <li>▪ Retail garden center between 90 Freeway lanes.</li> <li>▪ Caltrans right-of-way land not in use.</li> <li>▪ Dismantle 90 Freeway.</li> <li>○ Increased management only alternative.                             <ul style="list-style-type: none"> <li>▪ Remove homeless.</li> <li>▪ Increase patrols.</li> <li>▪ Stop dumping.</li> <li>▪ Clean up.</li> <li>▪ Bringing in researchers and observers.</li> <li>▪ Build visitors center.</li> <li>▪ Remove unauthorized uses (Gordon’s lot, defacto alleyway, etc.).</li> </ul> </li> <li>○ Return to 1800s alternative:                             <ul style="list-style-type: none"> <li>▪ Restoration plan based on site conditions existing before man began altering the land (200 years ago).</li> <li>▪ Balance of the eco-types: salt marsh, freshwater marsh, upland communities.</li> <li>▪ Return to the 1800s creeks.</li> <li>▪ New small channels (20-foot wide) entering Area A through Fisherman’s Village site and Area B through Los Angeles city-owned beach parcel (Del Rey Lagoon) going east through box culvert under Argonaut Place, then east into Area B via alley known as Culver Place, daylighting into the wetlands immediately south of the back dune.</li> </ul> </li> <li>○ Wildlife Friendly Alternative.                             <ul style="list-style-type: none"> <li>▪ Based on detailed, seasonal, unbiased baseline surveys of species and ecosystem.</li> <li>▪ Protect all rare and imperiled species and habitat.</li> <li>▪ Acquire more land: nine open spaces on edges of BW that are threatened by development.</li> <li>▪ Underground utility wires that cross BW.</li> <li>▪ Community-based restoration to remove nonnative plants using hand tools (no poisons or bulldozers).</li> <li>▪ Remove dead palms along Culver.</li> <li>▪ Secure reserve with fences to prevent dog, cat, and human trampling.</li> <li>▪ Calm traffic and encourage wildlife crossings.</li> <li>▪ Provide viewing platforms at four city-owned properties abutting BW and walking trail on Cabora Drive, with view areas, scopes, and interpretive signs.</li> <li>▪ Provide parking collaboratively with business and residential communities.</li> <li>▪ Restore plants and animals, with nesting platforms for bald eagles and osprey. Reintroduce roadrunner, Los Angeles sunflower, pocket mouse, California quail.</li> <li>▪ Apply rejuvenation principles.                                     <ul style="list-style-type: none"> <li>• 21st century, incremental, community involved ecosystem rejuvenation in harmony with natural laws; no industrial-scale habitat conversion, no major bulldozing.</li> <li>• Recognize resiliency of ecosystems; identify areas that require</li> </ul> </li> </ul> </li> </ul>



Resource	Comment Summary
	<p>no more than observation.</p> <ul style="list-style-type: none"> <li>• Give priority to acquisition/addition of additional unprotected parcels of land over restoration activities to increase habitat enhancing buffer zones, reduce animal road fatalities.</li> <li>• Utilize existing access (bike path, south levee); install walking/biking path around perimeter.</li> <li>• Utilize existing infrastructure (old railway bridge supports, etc.) and sustainable materials to create wildlife, bicycle, and walking linkages that go over or under roads and waterways that divide the refuge.</li> <li>• Underground all power, telephone, and cable lines and remove majority of street lighting.</li> <li>• Give priority to endangered, threatened, and imperiled species.</li> </ul> <ul style="list-style-type: none"> <li>○ Reduced scale alternatives                     <ul style="list-style-type: none"> <li>▪ Only add inlets from creek, remove invasive plants.</li> <li>▪ Do not remove channel; provide trails.</li> <li>▪ Do not remove trails.</li> <li>▪ Lesser management of wetlands.</li> <li>▪ Dig a few small channels to bring water into the wetlands; new small ocean access channels dug from Del Rey Lagoon on south side and through Fisherman’s Village on north; trail system and current habitat mix; preserve levees and bike path; small channels from creek near ocean where water is cleaner; use groundwater wells to provide upstream source of water in newly created creeks running through the wetlands.</li> <li>▪ Less disturbance (retain dunes, salt pans, and brackish salt marsh with native species; retain levees; use tide gates and active management; explicit protection for rare/endangered species present prior to 1880s; has biodiversity as goal).</li> <li>▪ Less movement of soil in Area A.</li> <li>▪ Not eliminating of surfaces in Area B.</li> </ul> </li> <li>○ Increased scale alternatives.                     <ul style="list-style-type: none"> <li>▪ Adding Del Rey Lagoon.</li> <li>▪ Adding land to project (between access road to 90 and townhomes abutting Area C).</li> <li>▪ Acquire additional land upstream, construct treatment wetland before discharging into Ballona Creek.</li> <li>▪ Acquire useful adjacent lands.</li> <li>▪ Add bike paths: Along 90 Freeway between Culver and Venice Beach; over old railroad bridge on south side of creek, circling around wetlands; connecting bluff paths below LMU through Playa vista to PDR; network through wetlands.</li> <li>▪ Expand to include watershed cleanup.</li> <li>▪ Acquire bluff for upland habitat.</li> <li>▪ Include adjacent water bodies (Marina del Rey harbor, Oxford Lagoon, Del Rey Lagoon, Venice canals, Santa Monica Bay).</li> </ul> </li> <li>○ No-project alternative.                     <ul style="list-style-type: none"> <li>▪ Continued degradation.</li> <li>▪ Loss of social/economic/watershed values/services.</li> </ul> </li> </ul>



Resource	Comment Summary
	<ul style="list-style-type: none"> <li>• Comments requested specific features be included in alternatives.               <ul style="list-style-type: none"> <li>○ Self-sustaining methods.</li> <li>○ Replacement of trails on new levees.</li> <li>○ Additional bikeways.</li> <li>○ Fiji Way access.</li> <li>○ Removal of levees and concrete from western end.</li> <li>○ Nature reserve with walking and hiking trails.</li> <li>○ Tide gates and preservation of freshwater areas.</li> <li>○ Path between Playa del Rey and freshwater marsh.</li> <li>○ Do not restrict bike routes.</li> <li>○ No access to Area C from La Villa Marina, improved fencing/walls, allow wildlife/water movement.</li> <li>○ Provide upper salt marsh and upland habitat as refuge for wading birds (light-footed clapper rail) during high tides and to support pollinators of salt marsh plants (salt marsh bird's beak).</li> <li>○ Include long-term management plan (inspections to identify maintenance needs, control of unauthorized access to habitats, fence maintenance, trash removal, restoration of habitats if disturbed by unauthorized use).</li> <li>○ Access (trails, boardwalks, overlooks).</li> <li>○ Limited parking to control amount of access.</li> <li>○ More tidal flow into Areas B and C.</li> <li>○ Allow marsh areas to treat Ballona Creek water.</li> <li>○ Small treatment wetlands along boundaries to treat offsite stormwater runoff.</li> <li>○ Maximize potential to sequester carbon dioxide in trees and wetland vegetation.</li> <li>○ Protect and create nesting habitat, rookeries, perches.</li> <li>○ Shut down SOCALGAS/ Semptra.</li> <li>○ More brackish wetland, less saltwater.</li> <li>○ Replace Culver with complete street—fewer car lanes, more bike lanes, hiking path, bike service station, observation platform on old railway bridge.</li> <li>○ Include comprehensive restoration of natural processes to wetlands, including tidal flow; maintain freshwater circulation; and support healthy ecosystems.</li> <li>○ Target greatest need for restoration first.</li> <li>○ Incorporate climate change into project planning, changes in temperature, increases in ocean acidity.</li> <li>○ Walking trail for south levee, Cabora Drive.</li> </ul> </li> <li>• Comments requested information be included in alternative descriptions.               <ul style="list-style-type: none"> <li>○ Project as treatment wetland.</li> <li>○ Maintenance activities.</li> <li>○ Access to publicly owned areas.</li> <li>○ Schedule for implementation/describe timing.</li> <li>○ Describe/show bike paths.</li> <li>○ Provide habitat maps for each alternative, with phasing.</li> <li>○ Discuss jurisdiction and oversight in future (who will operate/maintain).</li> </ul> </li> </ul>





Resource	Comment Summary
	<ul style="list-style-type: none"> <li>○ Freshwater circulation (what this means in relation to Ballona Creek).</li> <li>○ Flood control facilities (what property would be protected by levees).</li> <li>○ Earthmoving estimates for each alternative.</li> <li>○ Purpose and size of levees.</li> <li>○ Relationship to Port of LA wetland banking (if any).</li> <li>○ Provide illustrative plans.</li> <li>○ Relationship to freshwater marsh.</li> <li>○ Provide clear plans for specific wildlife benefits such as accommodation of wintering waterfowl or migrating shore birds.</li> </ul>
4.1 Geology	<ul style="list-style-type: none"> <li>● Analyze stability of Playa del Rey Bluffs.</li> <li>● Analyze increased liquefaction potential.</li> <li>● Analyze increase in subsidence.</li> <li>● Use current information.</li> <li>● Analyze earthquakes, liquefaction, tsunami risk.</li> <li>● Evaluate Lincoln Boulevard fault, including impacts related to flooding, aquifer.</li> </ul>
4.2 Paleontology	<ul style="list-style-type: none"> <li>● None.</li> </ul>
4.3 Water Resources	<ul style="list-style-type: none"> <li>● Evidence shows that Ballona would not be self-sustaining. <ul style="list-style-type: none"> <li>○ Sites that undergo drastic bulldozing and dredging are not self-sustaining.</li> </ul> </li> <li>● Analyze exposure to upstream pollution and mitigation.</li> <li>● Analyze flooding. <ul style="list-style-type: none"> <li>○ Address flooding hazards to nearby roadways, Marina del Rey, and other beach-front areas.</li> </ul> </li> <li>● Analyze sea level rise.</li> <li>● Analyze impaired waters issue. <ul style="list-style-type: none"> <li>○ Consider cleaning up stream before it reaches wetlands.</li> <li>○ Address issue: Under 303(d), an impaired waterway cannot further pollute another waterway; therefore, Ballona Creek cannot be allowed to flow into the wetlands. Water must be treated to tertiary levels first.</li> <li>○ Evaluate upstream flood control and contamination control.</li> </ul> </li> <li>● Study groundwater hydrology. <ul style="list-style-type: none"> <li>○ Analyze impacts to Ballona aquifer, groundwater, groundwater uses, saltwater intrusion.</li> <li>○ Analyze aquifer dewatering (ongoing at Playa Vista).</li> <li>○ Analyze Ballona aquifer, potential saltwater intrusion.</li> <li>○ Evaluate Lincoln Boulevard fault, including impacts related to flooding, aquifer.</li> <li>○ Evaluate impact of flooding wetlands on aquifer, and subsequently impacts to drinking water.</li> <li>○ Consequences of groundwater removal.</li> </ul> </li> <li>● Analyze impacts related to scour.</li> <li>● Analyze impacts related to trash and contamination. <ul style="list-style-type: none"> <li>○ Analyze impacts of trash on ocean if levees removed.</li> </ul> </li> <li>● Analyze impacts related to sedimentation. <ul style="list-style-type: none"> <li>○ Analyze impacts of sedimentation from relocating levees.</li> <li>○ Evaluate sediment impacts from contributing areas upstream.</li> <li>○ Consider consequences of sediment supply and reworking of</li> </ul> </li> </ul>



Resource	Comment Summary
	<p>sediments; project will likely draw significant sediment into the system; potential increased dredging.</p> <ul style="list-style-type: none"> <li>• Analyze how surface fresh/salt water will interact.</li> <li>• Analyze existing hydrology/hydrological dynamics of Ballona Creek outflow channel, interaction with bay, 303 waters, jetty, and wetland flows.</li> <li>• Discuss NPDES.                         <ul style="list-style-type: none"> <li>○ Consider age of pipelines and stormdrains and relation to Ballona (NPDES MS4 permit).</li> </ul> </li> <li>• Model first flush runoff to show if concentration would be significant.</li> <li>• Address impacts of sedimentation at mouth (littoral drift or sediment transport from creek); will inlet need periodic dredging; potential impact of maintaining BW as lagoon or ocean estuary.</li> <li>• Analyze saltwater contamination; protection of freshwater resources.</li> <li>• Evaluate impact of levees on water flow.</li> <li>• There is no justified need for any further flood control as the Ballona Channel provides adequate flood control.                         <ul style="list-style-type: none"> <li>○ Levees are used by the public for recreation and crew teams of multiple universities that have equipment and buildings adjacent to the channel.</li> <li>○ Per NOAA documentation, levee removal will invite toxic pollution of Ballona Wetlands.</li> <li>○ Science shows that a 6-square-mile area would be required to attempt to cleanse the toxins out of the water and sediment.</li> </ul> </li> <li>• Discuss tidal influence, sea-level rise, and tsunamis.</li> <li>• Consider pollution of Southern California Bight (as applicable).</li> <li>• Consider TMDL Storm Means data, including inadequacies in upland watershed.</li> <li>• Consider beneficial impacts of enhanced tidal flow.</li> <li>• Provide metrics for determining improvement in hydrology.</li> <li>• Analyze impacts related to macroalgal blooms.</li> <li>• Determine beneficial impacts to water quality and hydrology.                         <ul style="list-style-type: none"> <li>○ Evaluate beneficial impacts related to improvement of water quality of Ballona Creek, Marina del Rey harbor.</li> <li>○ Demonstrate beneficial and negative impacts of each alternative related to hydrology.</li> </ul> </li> <li>• Need to provide freshwater hydrological studies.                         <ul style="list-style-type: none"> <li>○ Need to quantify the damage done by allowing undisclosed drainage devices in the wetlands.</li> </ul> </li> </ul>
4.4 Biological Resources	<ul style="list-style-type: none"> <li>• Analyze impacts to existing wildlife.                         <ul style="list-style-type: none"> <li>○ Analyze impacts related to levees creating barriers for movement of fish, amphibians, reptiles, and invertebrates.</li> <li>○ Analyze impacts on wildlife from large levees.</li> <li>○ Analyze impact of flooding wetlands wildlife.</li> <li>○ Analyze possible impacts to wildlife from impacts to underground gas storage.</li> <li>○ Analyze impacts to wildlife (not just special-status).</li> <li>○ Analyze impacts on wildlife from extensive trail network (maintenance, people wandering off trail).</li> <li>○ Study wildlife use of adjacent water bodies (Marina del Rey harbor,</li> </ul> </li> </ul>



Resource	Comment Summary
	<p>Oxford Lagoon, Del Rey Lagoon, Venice Canals, Santa Monica Bay).</p> <ul style="list-style-type: none"> <li>○ Analyze impacts to small mammals.</li> <li>○ Analyze impacts to wildlife from construction traffic, air pollution, machinery.</li> <li>○ Address road kill impacts.</li> <li>○ Analyze impacts to wildlife from construction commuter traffic.</li> <li>○ Analyze impacts to birds who favor existing habitat mix.</li> <li>○ Analyze beneficial impacts to birds from proposed habitat mixes.</li> <li>● Analyze impacts to species.                         <ul style="list-style-type: none"> <li>○ Provide information about habitat needs for native special-status species (least tern, rails) or historical seasonal habitats (for tidewater goby, stickleback, reptiles, amphibians [south coast garter snake]).</li> <li>○ Analyze impacts to white-tailed kite, western meadowlark, California gnatcatcher, least Bell's vireo, blue-gray gnatcatcher, great blue heron, northern harrier, burrowing owl, great egret, ash-throated flycatcher, yellow-headed blackbird, Bullock's oriole, lazuli bunting, blue grosbeak, hooded oriole, barn owl, great horned owl, and tree swallow.</li> <li>○ Analyze impacts to western tiger swallowtail butterfly, monarch butterfly, El Segundo blue butterfly, pygmy blue butterfly, wandering skipper, painted lady butterfly, Acmon blue butterfly, mourning cloak, buckeye butterfly, Mormon metalmark, and red admiral.</li> <li>○ Analyze impacts to spiders, moths, mushroom and fungi, lichen, submerged aquatic vegetation, ant/ant-like species, dragonflies and damselflies, and beetles.</li> <li>○ Study species over time.</li> <li>○ Belding's savannah sparrow impacts.</li> <li>○ Analyze impact to ground-nesting bee species.</li> <li>○ Analyze impacts to burrowing owls.</li> <li>○ Address impacts to blue butterfly, shrike, kites, harriers, great blue heron.</li> <li>○ Cumulative impacts of Fisherman's Village, boat storage on egrets and herons.</li> <li>○ Address impacts to special-status species and freshwater species.</li> <li>○ Consider impacts to dunes at west end and El Segundo blue butterflies.</li> <li>○ Analyze construction impacts to burrowing species.</li> <li>○ Analyze annual flooding impacts to mid and high marsh species (nesting, burrowing).</li> <li>○ Analyze impacts to each special-status species.</li> <li>○ Analyze impacts on animals and plants, especially in upland habitats.</li> <li>○ Consider impacts from water quality, wildlife diversity, and public recreation and determine how these will affect species (which will gain, which will lose).</li> <li>○ Analyze impacts to species from flooding saltpan (i.e., loggerhead shrike).</li> <li>○ Analyze impacts to species from speed of restoration in sections.</li> <li>○ Analyze impacts to species from adding saltwater marsh.</li> <li>○ Analyze impacts to endemic species.</li> <li>○ Analyze impacts to California brown pelican and cross-eyed bubo.</li> <li>○ Provide qualitative and quantitative assessments of resources (USFWS</li> </ul> </li> </ul>



Resource	Comment Summary
	<p>species list).</p> <ul style="list-style-type: none"> <li>○ Provide new inventories and species counts.</li> <li>○ Evaluate impacts to coastal prairies and upland species, food chain (near, mid, far-term).</li> <li>○ Discuss impacts to species during construction.</li> <li>○ Discuss how species will be relocated during construction (special-status and non-special-status).</li> <li>○ Discuss how rare plants will be relocated.</li> <li>○ Provide species impact reports for all species and new species that will be introduced.</li> <li>○ Analyze impacts to species from soil elevation.</li> <li>○ Analyze impacts to species from changes in water/soil salinity and pH.</li> <li>○ Analyze potential reintroduction of: Los Angeles sunflower, saltmarsh bird's beak, Pacific pocket mouse, Ventura marsh milk-vetch, California quail, greater roadrunner, bald eagle (nesting), osprey (nesting), tidewater goby (all alternatives including no-build).</li> <li>○ Analyze impacts to least bittern, California brown pelican, redhead, peregrine falcon, white-tailed kite, elegant tern, California least tern, loggerhead shrike, Clark's marsh wren, Belding's savannah sparrow, large-billed savannah sparrow, yellow-headed blackbird, brant, northern harrier, western snowy plover, long-billed curlew, royal tern, burrowing owl, Vaux's swift, willow flycatcher, California Swainson's thrush, yellow warbler, American bittern, white-faced ibis, common moorhen, Pacific golden-plover, red knot, Wilson's phalarope, California quail, black-bellied plover, Bonaparte's gull, American pipit, western meadowlark, blue grosbeak, American white pelican, black skimmer, marbled murrelet, short-eared owl, horned lark, olive-sided flycatcher, bank swallow, yellow-breasted chat, light-footed clapper rail, black tern, bald eagle, fulvous whistling-duck, California black rail, sandhill crane, mountain plover, long-eared owl, Bell's sage sparrow, California gnatcatcher, snowy egret, great egret, black-necked stilt, red-tailed hawk, Cooper's hawk, American kestrel, common yellowthroat, and ash-throated flycatcher.</li> <li>○ Analyze impacts to El Segundo blue butterfly.</li> <li>○ Analyze impacts to Lewis' evening primrose.</li> <li>○ Analyze beneficial impacts related to restoring habitat for endangered and sensitive species in Ballona Wetlands.</li> <li>○ Analyze negative impacts to endangered and sensitive species in Ballona Wetlands.</li> <li>● Analyze impacts to existing habitats.             <ul style="list-style-type: none"> <li>○ Impacts of berms on habitat.</li> <li>○ Analyze impacts to subtidal habitat currently present in flood channel related to elimination of sediment redistribution.</li> <li>○ Analyze impacts related to elimination of natural surfaces and drainage, further isolation from marginal upland habitat.</li> <li>○ Analyze loss of upland habitat.</li> <li>○ Analyze impacts to great blue heron habitat.</li> <li>○ Assess direct, indirect, and cumulative impacts to fish and wildlife habitats.</li> <li>○ Include detailed maps and tables of habitat types (acres and</li> </ul> </li> </ul>



Resource	Comment Summary
	<p>locations).</p> <ul style="list-style-type: none"> <li>○ Provide up-to-date habitat information.</li> <li>○ Analyze impacts to habitats from concrete, steel, other unnatural materials.</li> <li>○ Analyze beneficial impacts to habitat.</li> <li>● Analyze impacts related to desiccation of marginal riparian habitat.</li> <li>● Analyze impacts to wetlands.</li> <li>● Analyze impacts related to first flush contaminants, facilitating eutrophic conditions and concentrating specific anthropogenic toxins in restoration area, exacerbated by sediment reworking.</li> <li>● Analyze impacts from visitors.                         <ul style="list-style-type: none"> <li>○ Analyze impacts from human contact (trampling, littering).</li> </ul> </li> <li>● Analyze exposure to upstream pollution and mitigation.</li> <li>● Consider National Audubon Society Important Bird Area.</li> <li>● Consider impacts to natural freshwater seep near old cottonwood tree near dunes.</li> <li>● Consider impacts to large salt panne and 1000s of migrating birds that use it.</li> <li>● Consider values of and impacts to current habitats.</li> <li>● Include thorough survey of native plants; consider collecting (as mitigation).</li> <li>● Analyze impacts on migratory birds from change in hydrology.</li> <li>● Analyze impacts to biodiversity.</li> <li>● Analyze impacts to ecosystem integrity.</li> <li>● Analyze impacts to migrating birds/nesting birds; mitigate.</li> <li>● Analyze impacts to feral cats (humane mitigation - trap, spay, release/relocate).</li> <li>● Consider maintenance of dynamic emerging wetlands without intervention (dredging, detention basin cleanup, etc.).</li> <li>● Discuss CDFW permits.</li> <li>● Consider benefits to listed species (including those that would be more likely to occur: Tidewater goby, California least tern).</li> <li>● Consider dynamic nature of estuarine habitat (short-term annual rainfall fluctuations, long-term sea level rise).</li> <li>● Discuss methodology of analysis (thoroughness, timing).</li> <li>● Evaluate impact of maintenance activities.</li> <li>● Evaluate impacts of earthmoving on plants/wildlife; how long to reestablish.</li> <li>● Analyze impacts to seasonal pond soil crusts during restoration or impacts to ecological systems if lost.</li> <li>● Address significance and impacts to Ballona Tule Fog.</li> <li>● Analyze impacts on marsh and inhabitants of year-round tidal openings.</li> <li>● Discuss equilibrium of existing ecosystems.</li> <li>● Discuss relationship to EPA wetlands avoidance criteria.</li> <li>● Demonstrate beneficial and negative impacts of each alternative related to trash removal.</li> <li>● Demonstrate beneficial and negative impacts of each alternative related to invasive species.</li> <li>● Analyze beneficial impacts of enhanced tidal flow.</li> </ul>



Resource	Comment Summary
	<ul style="list-style-type: none"> <li>• Evaluate each alternative for loss of native species and habitat types.</li> <li>• Analyze impacts of fertilizers used in replanting efforts</li> <li>• Analyze impacts to vegetation, ichthyofauna, herpetofauna, mammals, benthic vertebrates, and terrestrial invertebrates.</li> <li>• Analyze impacts from irrigation, if necessary.</li> <li>• Analyze impacts to herbivore species.</li> <li>• Analyze impacts related to macroalgal blooms.</li> <li>• Analyze impacts related to exotic plant invasions.</li> </ul>
5.1 Cultural Resources	<ul style="list-style-type: none"> <li>• Document consultation with NAHC.</li> <li>• Respect confidentiality.</li> <li>• Include human remains mitigation.</li> <li>• Consider preservation over mitigation through excavation.</li> <li>• Discuss importance of site archaeologically and historically, and as sacred site.</li> <li>• Discuss former use of Ballona Wetlands by native peoples.</li> <li>• Include pre-survey, monitoring, and recording to preserve/protect resources.</li> <li>• Analyze impacts to human graves.</li> <li>• Consult with Tongva.</li> <li>• Analyze impacts to cultural, historical, and religious resources.</li> </ul>
5.2 Land Use and Socioeconomics	<ul style="list-style-type: none"> <li>• Analyze consistency with Local Coastal Plan/Coastal Act.</li> <li>• Analyze compatibility of Area C with La Villa Marina neighborhood.</li> <li>• Discuss coastal zone permits.</li> <li>• Fully consider existing SoCalGas infrastructure and need to maintain full-time all-weather access for heavy equipment (Playa del Rey Storage Facility [natural gas storage field] and gas processing plant located immediately adjacent to southern boundary of project; multiple monitoring wells and associated piping located within project).</li> <li>• Analyze future use for gas extraction.</li> </ul>
5.3 Visual Resources	<ul style="list-style-type: none"> <li>• Analyze impacts of berms in Area C.</li> <li>• Analyze impacts of levees on views of Santa Monica Bay.</li> <li>• Consider impacts to views of wetlands.</li> </ul>
5.4 Transportation	<ul style="list-style-type: none"> <li>• Analyze impacts to La Villa Marina Street (nonissue if no gateway there).</li> <li>• Analyze traffic impacts (Culver/Playa del Rey area).</li> <li>• Analyze parking Impacts (Gordon’s Market lot).</li> <li>• Analyze impacts to pedestrian/ bikes during construction.</li> <li>• Analyze impacts to bike trails.</li> <li>• Analyze impacts to bike trail (length, accessibility).</li> <li>• Analyze construction and operational impacts on La Villa Marina (especially if construction or long-term access to Area C from here).</li> <li>• Analyze impact to creek trail (lengthening, visual access).</li> <li>• Analyze impacts during construction.</li> <li>• Analyze construction traffic in neighborhoods, on Lincoln, Culver, 90, Mindanao Fiji Way, Jefferson.</li> <li>• Analyze impacts related to use of Culver as Tsunami Escape Route.</li> </ul>
5.5 Air Quality	<ul style="list-style-type: none"> <li>• Analyze emissions/increased vehicles (hot spot at Gordon’s Market parking lot).</li> <li>• Analyze impacts during construction.</li> </ul>



Resource	Comment Summary
5.6 Greenhouse Gases	<ul style="list-style-type: none"> <li>• None.</li> </ul>
5.7 Noise	<ul style="list-style-type: none"> <li>• Analyze traffic noise (Culver).</li> <li>• Analyze vibration impacts from construction on existing condos.</li> </ul>
5.8 Hazards	<ul style="list-style-type: none"> <li>• Analyze impacts to neighbors health and safety (during construction).</li> <li>• Analyze impacts from SoCalGas ops and oilfield gas migration.</li> <li>• Address procedures and safety measures per DOGGR.</li> <li>• Analyze risk of upset from methane, oil.</li> <li>• Analyze safety impact to La Villa Marina neighborhood (near Area C).</li> <li>• Analyze impacts related to pollution, cleanup, well abandonment, and gas infusion.</li> <li>• Study impacts of earthwork on oilfield gas migration hazards, BTEX and H<sub>2</sub>S in oil gases.</li> <li>• Study impacts on leaking gases in gravel zone and effect of tidal action.</li> <li>• Study corrosion impacts of introducing saltwater and facilitating H<sub>2</sub>S on SoCalGas wells.</li> <li>• Study potential for more gas migration with tidal inundation.</li> <li>• Analyze nearby GeoTracker sites.</li> <li>• Analyze effects on Playa del Rey natural gas storage reservoir.</li> <li>• Analyze methane gas release due to subsidence.</li> <li>• Analyze impacts from/on SoCalGas and Sempra facilities (leaks, leaching, soils, water).</li> <li>• Analyze dredging (toxic materials).</li> <li>• Analyze impacts related to methane seeps.</li> <li>• Analyze impacts to underground gas storage from flooding wetlands with seawater and construction activities.</li> </ul>
5.9 Public Services and Recreation	<ul style="list-style-type: none"> <li>• Analyze impacts related to access to restoration area for first responders and vector control.</li> <li>• Analyze demonstrate beneficial and negative impacts of each alternative.</li> <li>• Analyze impacts to trails.</li> <li>• Analyze impacts related to eliminating current use of channel by UCLA and LMU crew teams.</li> </ul>
5.10 Utilities and Energy Use	<ul style="list-style-type: none"> <li>• None.</li> </ul>
6.1 Environmental Justice	<ul style="list-style-type: none"> <li>• None.</li> </ul>
6.2 Cumulative	<ul style="list-style-type: none"> <li>• None.</li> </ul>
6.3 Growth Inducing	<ul style="list-style-type: none"> <li>• None.</li> </ul>





**Attachment A**  
**Notice of Preparation and Notice of Intent**



# Notice of Completion & Environmental Document Transmittal

Mail to: State Clearinghouse, P.O. Box 3044, Sacramento, CA 95812-3044 (916) 445-0613  
For Hand Delivery/Street Address: 1400 Tenth Street, Sacramento, CA 95814

SCH # **2012071090**

## Project Title: Ballona Wetlands Restoration Project

Lead Agency: California Dept of Fish & Game Contact Person: David Lawhead  
Mailing Address: 3883 Ruffin Road Phone: 858-627-3997  
City: San Diego Zip: 92123 County: San Diego

Project Location: County: Los Angeles City/Nearest Community: Marina del Rey

Cross Streets: Hwy 1 & Fiji Way Zip Code: 90292

Longitude/Latitude (degrees, minutes and seconds): 33 ° 58 ' 33.83" N / 118 ° 26 ' 20.26" W Total Acres: 600

Assessor's Parcel No.: \_\_\_\_\_ Section: \_\_\_\_\_ Twp.: \_\_\_\_\_ Range: \_\_\_\_\_ Base: \_\_\_\_\_

Within 2 Miles: State Hwy #: 1 & 90 Waterways: Ballona Creek, Santa Monica Bay

Airports: Los Angeles Int'l Railways: \_\_\_\_\_ Schools: Multiple

## Document Type:

CEQA:  NOP  Draft EIR NEPA:  NOI Other:  Joint Document  
 Early Cons  Supplement/Subsequent EIR  EA  Final Document  
 Neg Dec (Prior SCH No.) \_\_\_\_\_  Draft EIS  Other: \_\_\_\_\_  
 Mit Neg Dec Other: \_\_\_\_\_  FONSI

## Local Action Type:

General Plan Update  Specific Plan  Rezone  Annexation  
 General Plan Amendment  Master Plan  Prezone  Redevelopment  
 General Plan Element  Planned Unit Development  Use Permit  Coastal Permit  
 Community Plan  Site Plan  Land Division (Subdivision, etc.)  Other: Restoration

## Development Type:

Residential: Units \_\_\_\_\_ Acres \_\_\_\_\_  
 Office: Sq.ft. \_\_\_\_\_ Acres \_\_\_\_\_ Employees \_\_\_\_\_  
 Commercial: Sq.ft. \_\_\_\_\_ Acres \_\_\_\_\_ Employees \_\_\_\_\_  
 Industrial: Sq.ft. \_\_\_\_\_ Acres \_\_\_\_\_ Employees \_\_\_\_\_  
 Educational: \_\_\_\_\_  
 Recreational: \_\_\_\_\_  
 Water Facilities: Type \_\_\_\_\_ MGD \_\_\_\_\_

Transportation: Type \_\_\_\_\_  
 Mining: Mineral \_\_\_\_\_  
 Power: Type \_\_\_\_\_  
 Waste Treatment: Type \_\_\_\_\_  
 Hazardous Waste: Type \_\_\_\_\_  
 Other: 600 acres of wetland restoration

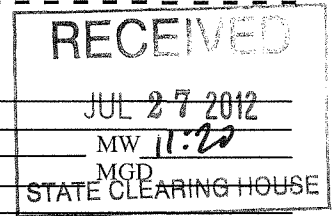

## Project Issues Discussed in Document:

Aesthetic/Visual  Fiscal  Recreation/Parks  Vegetation  
 Agricultural Land  Flood Plain/Flooding  Schools/Universities  Water Quality  
 Air Quality  Forest Land/Fire Hazard  Septic Systems  Water Supply/Groundwater  
 Archeological/Historical  Geologic/Seismic  Sewer Capacity  Wetland/Riparian  
 Biological Resources  Minerals  Soil Erosion/Compaction/Grading  Growth Inducement  
 Coastal Zone  Noise  Solid Waste  Land Use  
 Drainage/Absorption  Population/Housing Balance  Toxic/Hazardous  Cumulative Effects  
 Economic/Jobs  Public Services/Facilities  Traffic/Circulation  Other: \_\_\_\_\_

## Present Land Use/Zoning/General Plan Designation:

## Project Description: (please use a separate page if necessary)

The Ballona Wetlands Ecological Reserve is located in the western portion of the city of Los Angeles (partially within unincorporated Los Angeles County), south of Marina Del Rey and north of Playa Del Rey. The entire project site is held by the State of California, with part owned by CDFG and part owned by SLC. The site is bisected by and includes a channelized span of Ballona Creek, and it is traversed by Culver Boulevard, Jefferson Boulevard, and Lincoln Boulevard. The project entails restoring, enhancing, and creating native coastal wetland and upland habitats in the approximately 600-acre Ecological Reserve. The reserve comprises previously filled and dredged coastal wetland and upland habitat that would be restored by increasing tidal flow throughout the project area, removing invasive species, and planting native vegetation.

Note: The State Clearinghouse will assign identification numbers for all new projects. If a SCH number already exists for a project (e.g. Notice of Preparation or previous draft document) please fill in.

Revised 2010

**FILED**

JUL 27 2012

DEAN C. LOGAN  
REGISTRAR-RECORDER/COUNTY CLERK  
B. EVANS DEPUTY

**NOTICE OF PREPARATION OF A  
DRAFT ENVIRONMENTAL IMPACT REPORT**

**Ballona Wetlands Restoration Project**

**Introduction**

The California Department of Fish & Game (CDFG), the State Coastal Conservancy (Conservancy), and the California State Lands Commission (SLC) are considering a large-scale restoration of the Ballona Wetlands, a State-owned Ecological Reserve located in the western portion of the city and county of Los Angeles. As the primary landowner, project proponent, and permitting agency for the state, CDFG is serving as the lead agency under the California Environmental Quality Act (CEQA). The project will require permits from the U.S. Army Corps of Engineers, Los Angeles District (Corps), who will serve as lead agency under the National Environmental Policy Act (NEPA). The agencies are examining the environmental consequences associated with implementing the project. CDFG is hereby issuing this Notice of Preparation (NOP) that they will be preparing a draft environment impact report (EIR) to satisfy the environmental review requirements of CEQA. The Corps is also issuing a separate Notice of Intent to prepare a draft environment impact statement (EIS) to satisfy the requirements of NEPA. The two documents will be prepared as a joint document (EIS/EIR). This notice solicits input as to the content of environmental review for the project from the public and federal, state, and local agencies relevant to their respective statutory responsibilities.

**Project Location**

The Ballona Wetlands Ecological Reserve is located in the western portion of the city of Los Angeles (partially within unincorporated Los Angeles County), south of Marina Del Rey and north of Playa Del Rey, as shown in Figure 1. The site is approximately 1.5 miles west of Interstate 405 and approximately 0.25 mile east of Santa Monica Bay. The entire project site is held by the State of California, with part owned by CDFG and part owned by SLC. The site is bisected by and includes a channelized span of Ballona Creek, and it is traversed by Culver Boulevard, Jefferson Boulevard, and Lincoln Boulevard. An aerial photograph of the project site is shown in Figure 2.

**Project Summary and Proposed Action**

The project entails restoring, enhancing, and creating native coastal wetland and upland habitats in the approximately 600-acre Ecological Reserve. The reserve comprises previously filled and dredged coastal wetland and upland habitat that would be restored by increasing tidal flow throughout the project area, removing invasive species, and planting native vegetation. Figure 3 shows a conceptual design of the proposed restoration. The main components of the project are:

- Habitat restoration of estuarine wetland and upland habitats connected to a realigned Ballona Creek.
- Removal of existing Ballona Creek levees and realignment of Ballona Creek to restore a more meandering channel.
- Construction of new levees to replace the existing Ballona Creek levees and to allow restoration of tidally influenced wetlands while providing flood protection for Culver Boulevard and surrounding areas.
- Installation of water control structures, including culverts with self-regulating tide gates or similar structures, to provide a full range of tides up to an elevation acceptable for flood management and storm drainage, while protecting against some storm events.
- Maintenance of existing levels of flood protection for areas surrounding the Ballona Wetlands site and inclusion of flood hazard management measures into the restored wetlands.

12 0046154

THIS NOTICE WAS POSTED  
ON JUL 30 2012  
UNTIL AUG 28 2012  
REGISTRAR-RECORDER/COUNTY CLERK

CEFC 0046154  
JUL 8 2012

- Provision of erosion protection as an integral part of the restoration design.
- Modification of infrastructure and utilities as necessary to implement the restoration project.
- Improving public access by realigning existing trails, creating new trails, repairing existing fences, constructing overlook platforms, and providing other visitor-oriented facilities.
- Long-term operations and management activities including inspections, repairs, clean-up, vegetation maintenance, and related activities.

As this project is anticipated to be implemented over the course of several years, the project would include an adaptive management component whereby lessons learned from initial stages would be considered as further work is planned, designed, and implemented, allowing maximum realization of project objectives and minimization of on- and offsite environmental impacts. Additionally, the restoration and flood management approaches to the project will consider the effects of future sea-level rise, per the California Governor's Executive Order S-13-08 and the Conservancy's Climate Change Policy, adopted June 4, 2009.

The primary federal action associated with this project is the issuance by the Corps of permits pursuant to Clean Water Act Section 404 and Section 408. The 404 permit is required for dredge and fill of material within jurisdictional waters of the U.S.; the 408 permit is required for demolition of the concrete-lined flood control channel and realignment of Ballona Creek. The Corps and CDFG also anticipate formally consulting with the U.S. Fish and Wildlife Service under Section 7 of the Endangered Species Act, with the State Historic Preservation Officer under Section 106 of the National Historic Preservation Act, and with the Native American Heritage Commission regarding this project.

**Potential Environmental Effects**

The project's effects with respect to the following environmental issue areas will be analyzed and addressed in the EIS/EIR: aesthetics, air quality and greenhouse gas emissions, biological resources, cultural resources, geology and soils, hazards and hazardous materials, hydrology and water quality, land use and planning, noise, public services, recreation, sea-level rise, traffic, and utilities. Additional issues may be identified during the scoping process. The EIS/EIR will consider direct, indirect, and cumulative impacts, and will present a coequal level of detail for impact analysis on a reasonable range of alternatives to the project, including the No Action/No Project Alternative.

**Scoping Process**

CDFG and the Corps will conduct a public scoping meeting for the EIS/EIR to receive agency and public comment regarding the appropriate scope and preparation of the environmental document. Potential significant issues to be addressed in the EIS/EIR include aesthetics, air quality and greenhouse gas emissions, biological resources, cultural resources, geology and soils, hazards and hazardous materials, hydrology and water quality, land use and planning, noise, public services, recreation, sea-level rise, traffic, and utilities. Additional issues may be identified in during the scoping process. Comments are invited from the public and affected agencies.

A public scoping meeting to receive input on the scope of the EIS/EIR will be conducted on August 16, 2012, beginning at 4:00 pm at the Fiji Gateway entrance to the Ballona Wetlands (13720 Fiji Way, Marina del Rey, CA 90292, across from Fisherman's Village and the Los Angeles County Department of Beaches and Harbors). Participation in the public meeting by federal, state, and local agencies and other interested persons and organizations is encouraged. If you have any questions regarding the meeting, please contact Donna McCormick at (949) 333-6611 (Donna.Mccormick@icfi.com).

Written comments on the scope of environmental review may be submitted at the scoping meeting or sent to the address listed below. Comments will be accepted until September 10, 2012.

Ballona Wetlands Restoration Project  
C/O Donna McCormick  
1 Ada, Suite 100  
Irvine, CA 92816

or by email to:  
Donna.McCormick@icfi.com

Additional information on the project and the environmental review process is available on the Ballona Wetlands Restoration website at: [www.ballonarestoration.org](http://www.ballonarestoration.org).

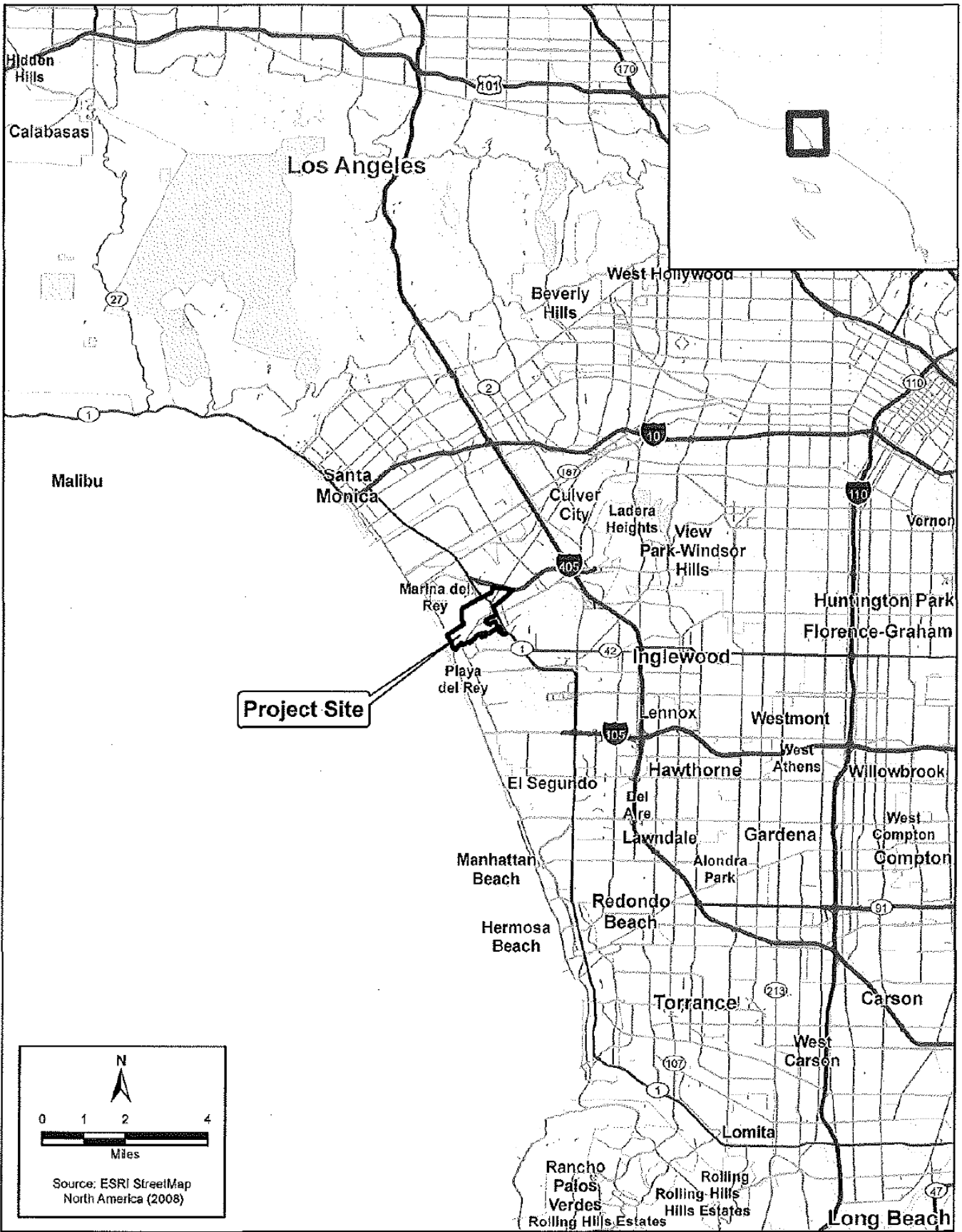

k:\san diego\projects\coastal\_concurrency\6553\_09\_ballops\_wetlands.mxd\ref1\_refloc.mxd TZ 110-07-10



12 0046154

Figure 1  
Regional Location



Source: Digital Globe Imagery, 2008



**Figure 2**  
**Project Site**

12 0046154

K:\san\_cfe\proj\projects\acastel\_conservancy\6518\_09\_helloma\_wetlands\msodoc\Fig03\_proposed\_project.ai SS (04.30.12)

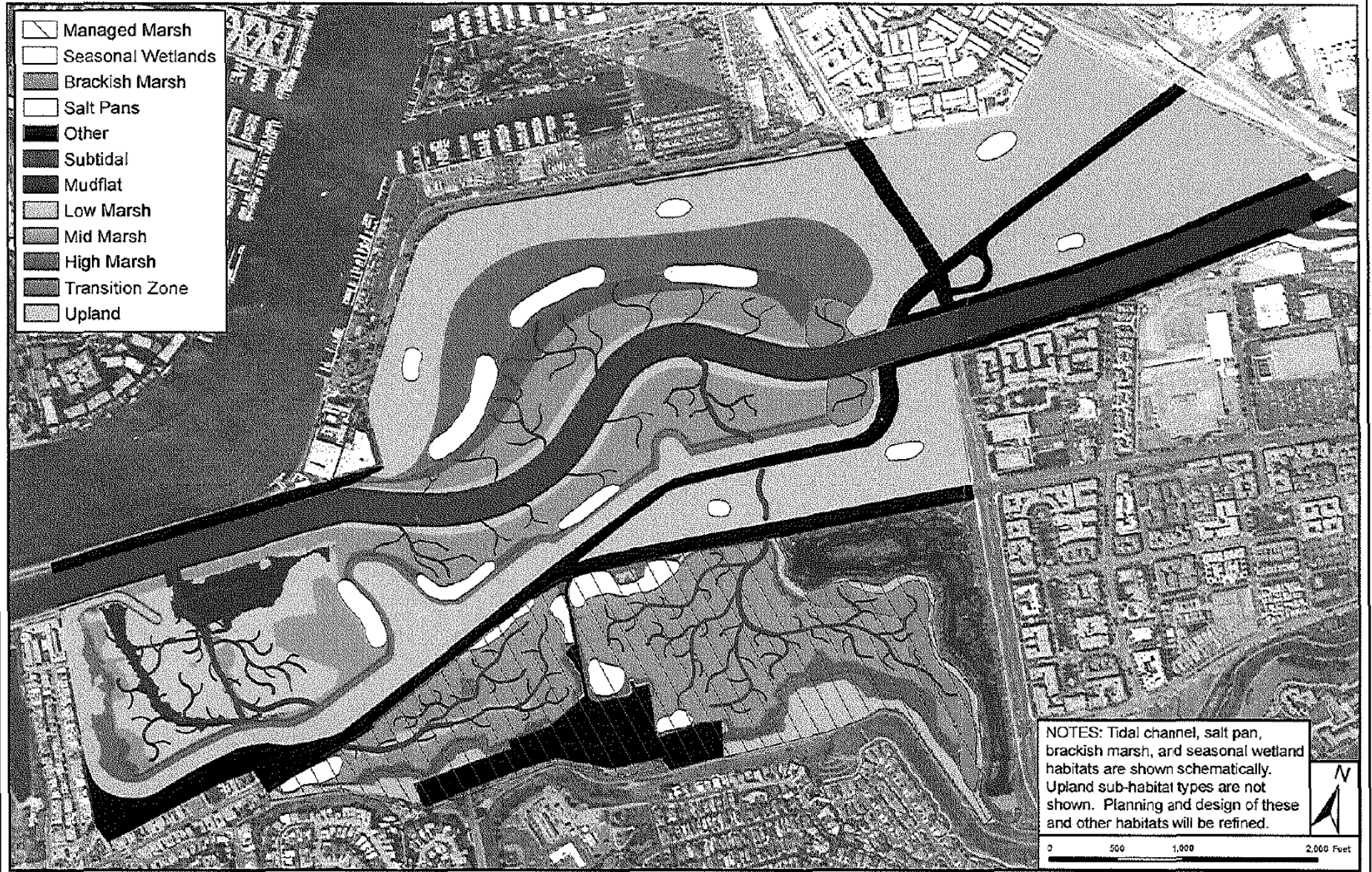

Source: ESA PWA



Figure 3  
Proposed Project

18 0040154

NOAA, Rm. 11230, 1315 East-West Highway, Silver Spring, Maryland 20910. Phone: 301-734-1156, Fax: 301-713-1459, Email: [Cynthia.Decker@noaa.gov](mailto:Cynthia.Decker@noaa.gov).

Dated: July 18, 2012.

**Terry Bevels,**

*Acting Chief Financial Officer/Acting Administrative Officer, Office of Oceanic and Atmospheric Research, National Oceanic and Atmospheric Administration.*

[FR Doc. 2012-18034 Filed 7-24-12; 8:45 am]

**BILLING CODE 3510-KD-P**

## DEPARTMENT OF DEFENSE

### Office of the Secretary

#### Department of Defense Wage Committee; Notice of Closed Meetings

**AGENCY:** Department of Defense (DoD).

**ACTION:** Notice of closed meetings.

**SUMMARY:** Pursuant to the provisions of section 10 of Public Law 92-463, the Federal Advisory Committee Act, notice is hereby given that closed meeting of the Department of Defense Wage Committee will be held.

**DATES:** Tuesday, September 4, 2012, at 10 a.m.

**ADDRESSES:** 4800 Mark Center Drive, Room 05K25, Alexandria, VA 22350-1100.

**FOR FURTHER INFORMATION CONTACT:** Additional information concerning the meetings may be obtained by writing to the Chairman, Department of Defense Wage Committee, 4000 Defense Pentagon, Washington, DC 20301-4000.

**SUPPLEMENTARY INFORMATION:** Under the provisions of section 10(d) of Public Law 92-463, the Department of Defense has determined that the meetings meet the criteria to close meetings to the public because the matters to be considered are related to internal rules and practices of the Department of Defense and the detailed wage data to be considered were obtained from officials of private establishments with a guarantee that the data will be held in confidence.

However, members of the public who may wish to do so are invited to submit material in writing to the chairman concerning matters believed to be deserving of the Committee's attention.

Dated: July 19, 2012.

**Aaron Siegel,**

*Alternate OSD Federal Register Liaison Officer, Department of Defense.*

[FR Doc. 2012-18097 Filed 7-24-12; 8:45 am]

**BILLING CODE 5001-06-P**

## DEPARTMENT OF DEFENSE

### Office of the Secretary

#### Department of Defense Wage Committee; Notice of Closed Meetings

**AGENCY:** Department of Defense (DoD).

**ACTION:** Notice of closed meetings.

**SUMMARY:** Pursuant to the provisions of section 10 of Public Law 92-463, the Federal Advisory Committee Act, notice is hereby given that closed meeting of the Department of Defense Wage Committee will be held.

**DATES:** Tuesday, September 18, 2012, at 10 a.m.

**ADDRESSES:** 4800 Mark Center Drive, Room 05K25, Alexandria, VA 22350-1100.

**FOR FURTHER INFORMATION CONTACT:** Additional information concerning the meetings may be obtained by writing to the Chairman, Department of Defense Wage Committee, 4000 Defense Pentagon, Washington, DC 20301-4000.

**SUPPLEMENTARY INFORMATION:** Under the provisions of section 10(d) of Public Law 92-463, the Department of Defense has determined that the meetings meet the criteria to close meetings to the public because the matters to be considered are related to internal rules and practices of the Department of Defense and the detailed wage data to be considered were obtained from officials of private establishments with a guarantee that the data will be held in confidence.

However, members of the public who may wish to do so are invited to submit material in writing to the chairman concerning matters believed to be deserving of the Committee's attention.

Dated: July 19, 2012.

**Aaron Siegel,**

*Alternate OSD Federal Register Liaison Officer, Department of Defense.*

[FR Doc. 2012-18112 Filed 7-24-12; 8:45 am]

**BILLING CODE 5001-06-P**

## DEPARTMENT OF DEFENSE

### Department of the Army, Corps of Engineers

#### Intent To Prepare a Draft Environmental Impact Statement/ Environmental Impact Report for the Proposed Ballona Wetlands Restoration Project at Ballona Creek Within the City and County of Los Angeles, CA

**AGENCY:** U.S. Army Corps of Engineers, Department of the Army, DoD.

**ACTION:** Notice of intent.

**SUMMARY:** The U.S. Army Corps of Engineers (Corps) and the California Department of Fish and Game (CDFG) intend to jointly prepare a Draft Environmental Impact Statement/ Environmental Impact Report (DEIS/ EIR) for the proposed Ballona Wetlands Restoration Project. The proposed project is intended to return the daily ebb and flow of tidal waters, maintain freshwater circulation, and augment the physical and biological functions and services in the project area. Restoring the wetland functions and services would allow native wetland vegetation to be reestablished, providing important habitat for a variety of wildlife species. As a restored site, the Ballona Wetlands would play an important role to provide seasonal habitat for migratory birds. A restored, optimally functioning wetland would also benefit the adjacent marine environment and enhance the quality of tidal waters.

**DATES:** Submit comments on or before September 10, 2012.

**FOR FURTHER INFORMATION CONTACT:** Dr. Daniel P. Swenson at (213) 452-3414

([daniel.p.swenson@usace.army.mil](mailto:daniel.p.swenson@usace.army.mil)), U.S. Army Corps of Engineers, Los Angeles District, P.O. Box 532711, Los Angeles, CA 90053-2325.

**SUPPLEMENTARY INFORMATION:** The Corps intends to prepare a joint EIS/EIR to assess the environmental effects associated with the proposed project. CDFG is the state lead agency for the EIR pursuant to the California Environmental Quality Act (CEQA).

1. Background. The 600-acre Ballona Wetlands Ecological Reserve is located in the western portion of the City of Los Angeles (partially within unincorporated Los Angeles County), south of Marina Del Rey and north of Playa Del Rey. The project site is situated approximately 1.5 miles west of Interstate 405 and approximately 1/4-mile east of Santa Monica Bay. The project site is owned by the State of California, and is bisected by and includes a channelized span of Ballona Creek, a component feature of a federal flood risk management project.

2. Project Purpose and Need. A substantial portion of California's historic coastal wetlands have been lost. Restoration of coastal wetlands is needed in order to increase available nursery and foraging habitat for wildlife and to provide recreational and educational opportunities to the public. The Ballona Wetlands ecosystem is one of the last remaining major coastal wetlands in Los Angeles County. It is estimated that historically the wetlands ecosystem spanned more than 2,000



acres in the vicinity of the site. Development occurring over the last century greatly reduced the Ballona wetland area, now estimated at approximately 600 acres. In addition, the wetland habitat and natural hydrological functions in the area have been substantially degraded. The project site provides habitat for a diversity of plant and wildlife species, but most on-site habitat exhibits relatively low physical and biological functions and services.

The proposed project is intended to return the daily ebb and flow of tidal waters, maintain freshwater circulation, and augment the physical and biological functions and services in the project area. Restoring the wetland functions and services would allow native wetland vegetation to be reestablished, providing important habitat for a variety of wildlife species. As a restored site, the Ballona Wetlands would play an important role to provide seasonal habitat for migratory birds. A restored, optimally functioning wetland would also benefit the adjacent marine environment and enhance the quality of tidal waters. The proposed project would provide the community with a valuable educational resource and access to a large wetland area.

The purpose of the project is to restore ecological functions of the site, in part, by enhancing tidal flow.

3. Proposed Action. CDFG is proposing a large-scale restoration of the Ballona Wetlands Ecological Reserve. The proposed project entails restoring, enhancing, and establishing native coastal wetland and upland habitats in the approximately 600-acre Ballona Wetlands Ecological Reserve. The reserve currently supports large expanses of previously filled and dredged coastal wetland and upland habitat that would be restored by increasing tidal flow throughout the project area, removing invasive species, and planting native vegetation.

The main components of the proposed project are:

- Habitat restoration of estuarine wetland and upland habitats connected to a realigned Ballona Creek.
- Removal of existing Ballona Creek levees and realignment of Ballona Creek to restore a more meandering channel.
- Construction of levees along the perimeter of the project area to allow restoration of tidally influenced wetlands in the project area while providing flood risk management for Culver Boulevard and surrounding developed areas.
- Installation of water control structures, including culverts with self-regulating tide gates or similar

structures, to provide a full range of tides up to an elevation acceptable for flood risk management and storm drainage, while reducing the risk of damage from storm events.

- Maintenance of existing levels of flood risk management for areas surrounding the Ballona Wetlands site.
- Provision of erosion protection as an integral part of the restoration design.
- Modification of infrastructure and utilities as necessary to implement the restoration project.
- Improving public access by realigning existing trails, creating new trails, repairing existing fences, constructing overlook platforms, and providing other visitor-oriented facilities.
- Long-term operations and management activities including inspections, repairs, clean-up, vegetation maintenance, and related activities.

The proposed project requires a permit under section 404 of the Clean Water Act (CWA) and section 10 of the Rivers and Harbors Act to conduct dredge and fill activities in waters of the United States and for work and (or) structures in or affecting navigable waters of the United States associated with restoring wetlands and associated habitat within the project site. Dredge and fill activities in waters of the United States are proposed to construct new levees, form new tidal channels, modify existing tidal channels, re-contour areas to enhance tidal flow, and to create elevations conducive to establishing wetland habitat. Preliminary conservative estimates indicate the project would result in a balanced total of 1,782,000 cubic yards of excavation and 1,782,000 cubic yards of fill placement, not all of which would affect jurisdictional areas. Based on these preliminary estimates, the volumes and areas of fill are estimated as follows: Permanent discharge of fill within 43.5 acres of non-wetland waters of the U.S. (435,000 cubic yards) and within 65 acres of wetland waters of the U.S. (600,000 cubic yards), as well as temporary discharge of fill within 3.5 acres of non-wetland waters of the U.S. (30,000 cubic yards) and within 0.3 acres of wetland waters of the U.S. (structural fill).

The project will also require a permit from the Corps to the Los Angeles County Department of Public Works, as the non-Federal sponsor of the Los Angeles County Drainage Area (LACDA) project, pursuant to 33 U.S.C. section 408 (408 permit). A section 408 permit is required to alter/modify a completed Corps project. The Ballona Creek levees were constructed by the Corps in the

1930s as part of LACDA. This project proposes to remove levees, construct a larger levee reach around the perimeter of the proposed side, reconfigure the existing concrete-lined Ballona Creek flood-control channel and realign the creek. A permit for modification/alteration of this magnitude would require Corps Headquarters approval.

4. Alternatives Considered. The feasibility of several alternatives is being considered and will be addressed in the DEIS/EIR. The No Federal Action/No Project Alternative, as required by NEPA and CEQA, would maintain the status quo and would include no improvements or discharges of fill material in waters of the United States or work or structures in or affecting navigable waters of the United States. Other alternatives that may be considered include restoring smaller portions of the 600-acre site, alternative designs that would provide differing amounts of various habitats types, and alternative designs for enhancing tidal flow. Additional alternatives may be developed during scoping and will also be considered in the DEIS/EIR.

#### 5. Scoping Process.

a. Affected federal, state and local resource agencies, Native American groups and concerned interest groups/individuals are encouraged to participate in the scoping process. Public participation is critical in defining the scope of analysis in the DEIS/EIR, identifying significant environmental issues in the DEIS/EIR, providing useful information such as published and unpublished data, and knowledge of relevant issues and recommending mitigation measures to offset potential impacts from proposed actions.

b. Potential impacts associated with the proposed project will be fully evaluated. Potential significant issues to be addressed in the DEIS/EIR include aesthetics, air quality and greenhouse gas emissions, biological resources, cultural resources, geology and soils, hazards and hazardous materials, hydrology and water quality, land use and planning, noise, public services, recreation, sea-level rise, traffic, flood control, and utilities. Additional issues may be identified during the scoping process.

c. Individuals and agencies may offer information or data relevant to the environmental or socioeconomic impacts of the proposed project by submitting comments, suggestions, and requests to be placed on the mailing list for announcements to (see **FOR FURTHER INFORMATION CONTACT**) or the following email address:

*Daniel.p.swenson@usace.army.mil.*

d. The Corps anticipates formally consulting with the U.S. Fish and Wildlife Service under Section 7 of the Endangered Species Act, the National Marine Fisheries Service under Section 305(b)(2) of the Magnuson-Stevens Fishery Conservation and Management Act (MSA), and with the State Historic Preservation Officer under Section 106 of the National Historic Preservation Act. The CDFG, as the project proponent, will need to obtain a CWA section 401 water quality certification or waiver and a consistency certification from the California Coastal Commission in accordance with the Coastal Zone Management Act.

6. Scoping Meeting Date, Time, and Location. A public scoping meeting to receive input on the scope of the DEIS/EIR will be conducted on August 16, 2012, from 4:00–7:00 p.m. at the Fiji Gateway entrance to the Ballona Wetlands (13720 Fiji Way, Marina del Rey, CA 90292, across from Fisherman's Village and Los Angeles County Department of Beaches and Harbors).

7. Availability of the DEIS/EIR. The DEIS/EIR is expected to be published and circulated in late 2012. A public hearing will be held after its publication to field comments on the document.

**David J. Castanon,**

*Chief, Regulatory Division, Corps of Engineers.*

[FR Doc. 2012–18166 Filed 7–24–12; 8:45 am]

**BILLING CODE 3720–58–P**

## DEPARTMENT OF DEFENSE

### Department of the Army, Corps of Engineers

#### Intent To Prepare an Environmental Impact Statement for the Proposed Westbrook Project, Corps Permit Application Number SPK–2005–00938

**AGENCY:** Department of the Army, U.S. Army Corps of Engineers, DOD.

**ACTION:** Notice of intent.

**SUMMARY:** The U.S. Army Corps of Engineers, Sacramento District, (Corps) received a Department of the Army permit application from Westpark S.V. 400, LLC (Applicant) to fill approximately 9.6 acres of waters of the United States to construct the proposed Westbrook Project in Placer County, CA, in June 2011. The Corps, as the lead agency responsible for compliance with the National Environmental Policy Act (NEPA), determined that the proposed project may result in significant impacts to the environment, and that the preparation of an Environmental Impact Statement (EIS) is required.

The Applicant proposes to implement a moderate scale, mixed-use, mixed-density master planned community. The Westbrook Project, as proposed, would include a mixture of land uses, including new residential neighborhoods, elementary school, parks and several neighborhood serving retail centers. The Westbrook Project would involve approximately 146 acres of low-density residential, 84 acres of medium-density residential, 28 acres of high-density residential and 43 acres of commercial land uses. Other proposed land uses include a 10-acre elementary school site, approximately 16 acres for three neighborhood parks, and approximately 37 acres of open space for the preservation of natural resources areas.

The proposed project site is approximately 400 acres and contains approximately 13 acres of waters of the United States. The project, as proposed, would result in direct impacts to approximately 9.6 acres of waters of the United States. These acreages do not include indirect impacts from the proposed action or impacts anticipated to result from offsite infrastructure that may be determined to be required as part of the project through the Environmental Impact Statement (EIS) process.

**ADDRESSES:** To submit comments on this notice or for questions about the proposed action and the Draft EIS, please contact James T. Robb, 1325 J Street, Room 1350, Sacramento, CA 95814. Please refer to Identification Number SPK–2005–00938 in any correspondence.

**FOR FURTHER INFORMATION CONTACT:** Mr. James T. Robb, (916) 557–7610, email: [DLL-CESPK-RD-EIS-Comments@usace.army.mil](mailto:DLL-CESPK-RD-EIS-Comments@usace.army.mil).

**SUPPLEMENTARY INFORMATION:** Interested parties are invited to submit written comments on the permit application on or before September 3, 2012. Scoping comments should be submitted within the next 45 days, but may be submitted at any time prior to publication of the Draft EIS.

The USACE will evaluate alternatives including the no action alternative, the proposed action alternative, and other on-site and off-site alternatives. The proposed project and the alternatives to its proposed size, design, and location will be developed through the EIS process.

The proposed project would result in direct impacts to approximately 9.6 acres of waters of the United States and would avoid approximately 2.9 acres of these waters of the United States. Waters of the U.S. on-site include two

intermittent streams, seasonal wetlands, wetland swales, and vernal pools.

The proposed site for the Westbrook community is in unincorporated Placer County, CA, immediately west of the City of Roseville's existing city limits. The proposed project site is approximately 6 miles west of Interstate 80 and State Route 65, 10 miles northeast of the City of Sacramento, 10 miles east of State Route 99, 5 miles west of downtown Roseville, and 4 miles east of the Sutter County line. The proposed project site is bordered on the west by Fiddymont Road and is approximately 1.2 miles north of Baseline Road. The property to the north was previously authorized for development under permit SPK–2002–00666 (Westpark/Fiddymont Ranch) or is under review in the case of Creekview (SPK–2006–00650). The property to the south, directly adjacent to Baseline Road, is currently under review (Sierra Vista Specific Plan, SPK–2006–01050 and Placer Vineyards, SPK–1999–00737). The proposed project site was once a part of the Sierra Vista Specific Plan area, but the landowners at the time withdrew their application for a Section 404 permit and the area was dropped from analysis under the Sierra Vista EIS in 2008. A new permit application was received for the proposed Westbrook project on June 9, 2011.

The Corps' public involvement program includes several opportunities to provide oral and written comments on the Westbrook project through the EIS drafting process. Affected federal, state, and local agencies, Indian tribes, and other interested private organizations and parties are invited to participate. Significant issues to be analyzed in depth in the EIS include impacts to waters of the United States, including vernal pools and other wetlands; agricultural resources; cultural resources; threatened and endangered species; transportation; air quality; surface water and groundwater; hydrology and water quality; socioeconomic effects; and aesthetics.

The applicant reports that the project area supports suitable habitat for certain federally-listed branchiopods, including the threatened vernal pool fairy shrimp (*Branchinecta lynchi*) and endangered Conservancy fairy shrimp (*Branchinecta conservatio*) and vernal pool tadpole shrimp (*Lepidurus packardii*). The suitable habitat for branchiopods within the project area includes vernal pools and depressional seasonal wetlands (including depressional areas within wetland swales).

The Applicant reports that there are historic properties within the Westbrook



**Attachment B**  
**Public Notice for Scoping Meeting**

## HEALTH & NUTRITION

**24/7 EMERGENCY RESPONSE \$1/day.** Living alone? You could fall! Deaths from falls can be avoided. Help is a button push away. Lifewatch 1-800-207-4048. (Cal-SCAN)

**Attention Joint & Muscle Pain Sufferers:** Clinically proven all-natural supplement helps reduce pain and enhance mobility. Call 877-217-7698 to try Hydroflexin RISK-FREE for 90 days. (Cal-SCAN)

**BLISSFUL RELAXATION!** Experience Tranquility & Freedom from Stress through Nurturing & Caring touch in a total healing environment. Lynda, LMT: 310-749-0621

**Canada Drug Center is your choice for safe and affordable medications.** Our licensed Canadian mail order pharmacy will provide you with savings of up to 90 percent on all your medication needs. Call Today 866-723-7089 for \$10.00 off your first prescription and free shipping. (Cal-SCAN)

**CANADA DRUG CENTER.** Safe and affordable medications. Saves up to 90% on your medication needs. Call 1-888-734-1530 (\$25.00 off your first prescription and free shipping.) (CADnet)

## HEALTH & NUTRITION

**Feeling older?** Men lose the ability to produce testosterone as they age. Call 888-904-2372 for a FREE trial of Progena- All Natural Testosterone Supplement. (Cal-SCAN)

**Feeling older?** In men, testosterone declines as they age. Call 1-866-455-0652 for a FREE trial of Progena- Natural Testosterone Supplement. (CADnet)

**Over 30 Million Women Suffer From Hair Loss! Do you? If So We Have a Solution! CALL KERANIQUE TO FIND OUT MORE 888-690-0395.** (Cal-SCAN)

**SWEDISH BODYWORK.** Healing hands with mature people at reasonable rates. 310-458-6798

**SWEDISH DEEP TISSUE BODYWORK.** Great rate. Call Shelley. 310-936-3436.

**TAKE VIAGRA? SAVE \$50!** 100mg/Cialis 20mg. 40+ FREE. PILLS. Only \$99.00. Discreet. 1-888-797-9024 (CADnet)

## SCHOOLS & INSTRUCTION

**AIRLINE CAREERS** begin here - Become an Aviation Maintenance Tech. FAA approved training. Financial aid if qualified - Housing available. Job placement assistance. Call AIM (866)453-8204. (CADnet)

**ATTEND COLLEGE ONLINE** from Home. \*Medical, \*Business, \*Criminal Justice, \*Hospitality. Job placement assistance. Computer available. Financial Aid if qualified. Call 800-494-3586 www.CenturaOnline.com. (CADnet)

**ATTEND COLLEGE ONLINE** from Home. \*Medical, \*Business, \*Criminal Justice, \*Hospitality. Job placement assistance. Computer available. Financial Aid if qualified. SCHEV certified. Call 888-210-5162 www.CenturaOnline.com (Cal-SCAN)

**Finish High School** at home in a few weeks. First Coast Academy, 1-800-658-1180x130. www.fcathighschool.org (CADnet)

**HIGH SCHOOL PROFICIENCY DIPLOMA!!!** 4 week Program. FREE Brochure & Full Information. Call Now! 1-866-522-3650 ext. 50 www.SouthEasternHS.com (Cal-SCAN)

## SELF IMPROVEMENT

**FREE CD** Are you ready to improve your life? Learn the secrets of success. 424-234-8124

## LEGAL ADVERTISING

Our new lower prices Help make placing YOUR Legal ad easier than ever! Call Joy at 310-822-1629 ext 103

## SINGLES SERVICES

**Meet singles right now!** No paid operators, just real people like you. Browse greetings, exchange messages and connect live. Try it free. Call now 1-888-908-9950. (CADnet)

## TV, VCR, STEREO REPAIR

**Direct To Home Satellite TV \$19.99/mo.** Free Installation FREE HD/DVR Upgrade Credit/Debit Card Req. Call 1-800-795-3579. (CADnet)

## WHEELS AUTOS WANTED

**\$2000-\$6000 for Honda Toyota Nissan & Other Small Cars**  
Fast Polite Local Service Since 1975 (310) 866-1303

**60's & 70's Vans & Cars \$1500 to \$7000 Cash**  
Local Enthusiast & Collector Since 1975 (310) 866-1303

## AUTOS WANTED

**Attention We Bring You \$1500 to \$6000 Cash for Cars Trucks Vans SUVs**  
Fast Polite Local Service Since 1975 (310) 866-1303

**DONATE YOUR CAR, truck or boat to Heritage for the Blind.** Free 3 Day Vacation, Tax Deductible, Free Towing. All Panenwork Taken Care Of. 888-902-6851. (Cal-SCAN)

**I BUY ANY JUNK CAR - \$300 Flat Rate**  
Includes Pick-Up. 1-800-277-1569. Please call for areas serviced. (Cal-SCAN)

## BOATING

### BOATSLIP RENTAL

**BOAT SLIPS 24' & 26' STARTING AT \$274/mo.**  
\$99 DEPOSIT SPECIAL  
Water, electricity, restrooms, showers, access to pool, spa and laundry.  
**NEPTUNE MARINA**  
14126 Marguerite Way, Ste. A, Marina del Rey, CA 90292  
310-823-4555

### PARTNERSHIPS

**31' CATALINA 2004: Share ownership.** Like new. In MdR slip. 310-475-5607.

### POWERBOATS FOR SALE

**13' Boston Whaler SS '09: 40hp Merc.** Transferable warranty on boat/motor. \$9,500. 310-301-1519

**LET'S GO FISHING!**  
18.5' Speed boat. Like new. Volvo engine. Seats 7.  
\$10,000. 310-301-9282

### SAILBOATS FOR SALE

**29' ERICSON '72 \$2,500.** Great live-aboard. Sleeps 5, pressurized H2O, shower, alcohol stove, roller furling, extra sails, GPS, 2 radios, dingy & other extras. Solid but needs paint & Atomic 4 needs new or rebuilt. 310-359-5218.

**P.O. BOX 2 Months FREE PACKAGING & SHIPPING U.P.S. / FedEx 310-823-7802**  
POSTAL MASTERS

## LEGAL ADVERTISING

### FICTITIOUS BUSINESS NAME STATEMENT File No. 2012 127121

The following person is doing business as: Millennium Media and Graphics, 1421 Walgrove Ave., Los Angeles, CA 90066, County of Los Angeles. Articles of Incorporation or Organization Number: AI #0N: Registered owner: Andreas P. Vogel, 1421 Walgrove Ave., Los Angeles, CA 90066. This business is conducted by an individual. The registrant commenced to transact business under the fictitious business name or names listed above on N/A. I declare that all information in this statement is true and correct. (A registrant who declares as true information which he or she knows to be false is guilty of a crime.) Registrant Signature/Name: Andreas P. Vogel, Owner. This statement was filed with the County Clerk of Los Angeles on June 25, 2012. Argonaut published: July 19, 26, August 2, 9, 2012. NOTICE-in accordance with Subdivision (a) of Section 17920, a Fictitious Name Statement generally expires at the end of five years from the date on which it was filed in the office of the County Clerk, except, as provided in Subdivision (b) of Section 17920, where it expires 40 days after any change in the facts set forth in the statement pursuant to section 17913 other than a change in the residence address of a registered owner. A New Fictitious Business Name Statement must be filed before the expiration. The filing of this statement does not of itself authorize the use in this state of a Fictitious Business Name in violation of the rights of another under Federal, State, or common law (See Section 14411 et seq., Business and Professions Code).

### FICTITIOUS BUSINESS NAME STATEMENT File No. 2012 129391

The following person is doing business as: Studio MD, 4048 Madison Ave., Culver City, CA 90232, County of Los Angeles. Articles of Incorporation or Organization Number: AI #0N: Registered owner: Mauricio Djk, 4048 Madison Ave., Culver City, CA 90232. This business is conducted by an individual. The registrant commenced to transact business under the fictitious business name or names listed above on 6/15/2012. I declare that all information in this statement is true and correct. (A registrant who declares as true information which he or she knows to be false is guilty of a crime.) Registrant Signature/Name: Mauricio Djk, Principal. This statement was filed with the County Clerk of Los Angeles on June 27, 2012. Argonaut published: July 26, August 2, 9, 16, 2012. NOTICE-in accordance with Subdivision (a) of Section 17920, a Fictitious Name Statement generally expires at the end of five years from the date on which it was filed in the office of the County Clerk, except, as provided in Subdivision (b) of Section 17920, where it expires 40 days after any change in the facts set forth in the statement pursuant to section 17913 other than a change in the residence address of a registered owner. A New Fictitious Business Name Statement must be filed before the expiration. The filing of this statement does not of itself authorize the use in this state of a Fictitious Business Name in violation of the rights of another under Federal, State, or common law (See Section 14411 et seq., Business and Professions Code).

### FICTITIOUS BUSINESS NAME STATEMENT File No. 2012 130970

The following persons are doing business as: Blue Cat Garden Design, 777 Gaviota Ave., Long Beach, CA 90813, County of Los Angeles. Articles of Incorporation or Organization Number: AI #0N: Registered owners: 1. Mary Kingman, 777 Gaviota Ave., Long Beach, CA 90813. 2. Ashley Kingman, 777 Gaviota Ave., Long Beach, CA 90813. This business is conducted by a Husband and Wife. The registrant commenced to transact business under the fictitious business name or names listed above on N/A. I declare that all information in this statement is true and correct. (A registrant who declares as true information which he or she knows to be false is guilty of a crime.) Registrant Signature/Name: Mary Kingman, Owner. This statement was filed with the County Clerk of Los Angeles on June 28, 2012. Argonaut published: July 12, 19, 26, August 2, 2012. NOTICE-in accordance with Subdivision (a) of Section 17920, a Fictitious Name Statement generally expires at the end of five years from the date on which it was filed in the office of the County Clerk, except, as provided in Subdivision (b) of Section 17920, where it expires 40 days after any change in the facts set forth in the statement pursuant to section 17913 other than a change in the residence address of a registered owner. A New Fictitious Business Name Statement must be filed before the expiration. The filing of this statement does not of itself authorize the use in this state of a Fictitious Business Name in violation of the rights of another under Federal, State, or common law (See Section 14411 et seq., Business and Professions Code).

### FICTITIOUS BUSINESS NAME STATEMENT File No. 2012 133827

The following persons are doing business as: Hana Nails, 13700 W. Washington Blvd. # 100, Marina del Rey, CA 90292, County of Los Angeles. Articles of Incorporation or Organization Number: AI #0N: Registered owners: Hana Nail Salon, Inc., 13700 W. Washington Blvd. # 100, Marina del Rey, CA 90292. This business is conducted by a Corporation. The registrant commenced to transact business under the fictitious business name or names listed above on 7/28/2009. I declare that all information in this statement is true and correct. (A registrant who declares as true information which he or she knows to be false is guilty of a crime.) Registrant Signature/Name: Hang Wohlstafer, President (Owner) Hana Nail Salon, Inc. This statement was filed with the County Clerk of Los Angeles on July 9, 2012. Argonaut published: July 9, 26, August 2, 9, 2012. NOTICE-in accordance with Subdivision (a) of Section 17920, a Fictitious Name Statement generally expires at the end of five years from the date on which it was filed in the office of the County Clerk, except, as provided in Subdivision (b) of Section 17920, where it expires 40 days after any change in the facts set forth in the statement pursuant to section 17913 other than a change in the residence address of a registered owner. A New Fictitious Business Name Statement must be filed before the expiration. The filing of this statement does not of itself authorize the use in this state of a Fictitious Business Name in violation of the rights of another under Federal, State, or common law (See Section 14411 et seq., Business and Professions Code).

### FICTITIOUS BUSINESS NAME STATEMENT File No. 2012 135623

The following persons are doing business as: The Sandbox, 642 Broadway St., Venice, CA 90291, County of Los Angeles. Articles of Incorporation or Organization Number: AI #0N: Registered owners: 1. Robert Todd Sali, 642 Broadway St., Venice, CA 90291. 2. Brigitte Holsten, 642 Broadway St., Venice, CA 90291. This business is conducted by Husband and Wife. The registrant commenced to transact business under the fictitious business name or names listed above on N/A. I declare that all information in this statement is true and correct. (A registrant who declares as true information which he or she knows to be false is guilty of a crime.) Registrant Signature/Name: Robert Todd Sali. This statement was filed with the County Clerk of Los Angeles on July 5, 2012. Argonaut published: July 19, 26, August 2, 9, 2012. NOTICE-in accordance with Subdivision (a) of Section 17920, a Fictitious Name Statement generally expires at the end of five years from the date on which it was filed in the office of the County Clerk, except, as provided in Subdivision (b) of Section 17920, where it expires 40 days after any change in the facts set forth in the statement pursuant to section 17913 other than a change in the residence address of a registered owner. A New Fictitious Business Name Statement must be filed before the expiration. The filing of this statement does not of itself authorize the use in this state of a Fictitious Business Name in violation of the rights of another under Federal, State, or common law (See Section 14411 et seq., Business and Professions Code).

## PUBLIC NOTICE

### NOTICE OF PUBLIC SCOPING MEETING for Ballona Wetlands Restoration Project

The California Department of Fish & Game (CDFG), the State Coastal Conservancy (Conservancy), and the California State Lands Commission (SLC) are considering a large-scale restoration of the Ballona Wetlands. The Ballona Wetlands are a state-owned Ecological Reserve located in the western portion of the city of Los Angeles (partially within unincorporated Los Angeles County), south of Marina Del Rey and north of Playa Del Rey. The site is approximately 1.5 miles west of Interstate 405 and approximately 0.25 mile east of Santa Monica Bay.

The Ballona Wetlands Restoration Project entails restoring, enhancing, and creating native coastal wetland and upland habitats in the approximately 600-acre Ecological Reserve. The reserve comprises previously filled and dredged coastal wetland and upland habitat that would be restored by increasing tidal flow throughout the project area, removing invasive species, and planting native vegetation.

CDFG and the U.S. Army Corps of Engineers (Corps) have initiated the required environmental documentation process and will prepare a joint environmental impact report/environmental impact statement (EIR/EIS) to analyze potential effects the proposed project alternatives may have on the environment. This notice is to inform you of the scheduled public scoping meeting for this project. The scoping meeting will provide you an opportunity to tell the agencies what issues you would like to see addressed in the EIR/EIS. Once the analysis is complete, the Draft EIR/EIS will be released and the public will again have an opportunity to comment.

The scoping meeting will be an open house. You may attend the meeting anytime between 4:00 and 7:00 PM on Thursday, August 16, 2012. You will have the opportunity to provide your comments in writing at the meeting or by dictating your comments to recorders at the meeting. You may also send your comments to the address below any time before September 10, 2012.

<b>SCOPING MEETING</b>	
<b>Date &amp; Time:</b> Thursday, August 16, 2012, 4:00-7:00 PM	
<b>Location:</b> Fiji Gateway entrance to Ballona Wetlands. 13720 Fiji Way, Marina del Rey, CA 90292 <i>Across from Fisherman's Village &amp; Los Angeles County Dept. of Beaches &amp; Harbors</i>	
<b>FOR MORE INFORMATION, CONTACT:</b>	
Donna McCormick, ICF International, (949) 333-6611 Donna.McCormick@icfi.com	
David Lawhead, California Dept. of Fish & Game, (858) 627-3997 DLawhead@dfg.ca.gov	
Dr. Daniel P. Swenson, U.S. Army Corps of Engineers, Los Angeles District (213) 452-3414, Daniel.P.Swenson@usace.army.mil	
<b>SEND COMMENTS TO:</b>	
<b>Ballona Wetlands Restoration Project</b>	
C/O Donna McCormick 1 Ada, Suite 100 Irvine, CA 92816	
<b>or by email to:</b> Donna.McCormick@icfi.com	

Additional information on the project and the environmental review process is available on the Ballona Wetlands Restoration website at: [www.ballonarestoration.org](http://www.ballonarestoration.org).



**Attachment C**  
**Public Comments**

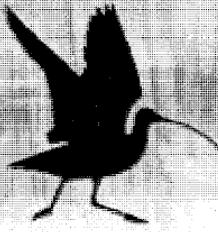

# Ballona Wetlands Restoration Project

Advancing ecosystem health. Connecting communities with nature.

## Comment Card

Name: ERIC ANDRES

Email: (optional) ANDRESHOUSE@ATT.NET

Add me to the mailing list (please provide email or mailing address): \_\_\_\_\_

Comments/Issues: (Use additional sheets if necessary)

1) SHOULD BE A PUBLIC HEARING

2) "NO" GATEWAY IN PLAYA DEL REY  
OFF OF CULVERT BLVD

3) GET RESIDENTS FEEDBACK  
& DISPLAY PUBLIC COMMENTS  
ON YOUR WEBSITE

4) FOR 3 YEARS PDR RESIDENTS  
HAVE COMMUNICATED "NO"  
GATEWAY IN PDR, WHY IS  
NO ONE LISTENING?

Submit written comments by **October 23, 2012** to:

Mail: Ballona Wetlands Restoration Project  
C/O Donna McCormick  
1 Ada, Suite 100  
Irvine, CA 92618

Email: [Donna.McCormick@icfi.com](mailto:Donna.McCormick@icfi.com)

**\*\*All comments submitted will become part of the Public Record**



# Ballona Wetlands Restoration Project

Advancing ecosystem health. Connecting communities with nature.

## Comment Card

Name: FRAN BIBIAN

Email: (optional) FRANBIBIAN@SBCGLOBAL.NET

Add me to the mailing list (please provide email or mailing address): \_\_\_\_\_

Comments/Issues: (Use additional sheets if necessary) \_\_\_\_\_

I WOULD LOVE TO SEE THIS SITE TO BE TURNED INTO A  
MINI "HEAVEN ON EARTH", A PLACE WITH CLEAN WATER,  
CLEAN AIR AND CLEAN SOILS. A PLACE WHERE PEOPLE CAN  
ENJOY A BEAUTIFUL WALK AND NATURE OBSERVATION, A PLACE  
WHERE WILD LIFE IS SAFE AND PROTECTED. I WOULD LOVE TO  
HAVE THIS IN A PLACE WITH PERFECT WEATHER! WELL, THIS IS SO  
CLOSE TO IT.

THE PROCESS OF GETTING THERE SHOULD BE RESPECTFUL AND  
SENSITIVE TO THE NEEDS AND CONCERNS OF ALL STAKEHOLDERS  
(LOCAL RESIDENTS, BUSINESSSES, ETC...), IT MAY BE DIFFICULT  
TO DO, BUT IT IS DOABLE.

GOOD LUCK TO YOU ALL.

Submit written comments by **October 23, 2012** to:

Mail: Ballona Wetlands Restoration Project  
C/O Donna McCormick  
1 Ada, Suite 100  
Irvine, CA 92618

Email: [Donna.McCormick@icfi.com](mailto:Donna.McCormick@icfi.com)

**\*\*All comments submitted will become part of the Public Record**

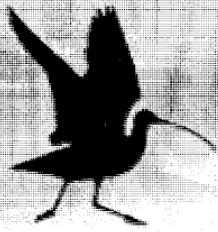

# Ballona Wetlands Restoration Project

Advancing ecosystem health. Connecting communities with nature.

## Comment Card

Name: FRAN BIBIAN

Email: (optional) FRANBIBIAN@SBCGLOBAL.NET

Add me to the mailing list (please provide email or mailing address): \_\_\_\_\_

Comments/Issues: (Use additional sheets if necessary) \_\_\_\_\_

*oops! I forgot to mention that it would be great to have a place for riding bikes, and would be great to have plenty of trees to keep the trail(s) shaded*

*Thank you —*

Submit written comments by **October 23, 2012** to:

Mail: Ballona Wetlands Restoration Project  
C/O Donna McCormick  
1 Ada, Suite 100  
Irvine, CA 92618

Email: [Donna.McCormick@icfi.com](mailto:Donna.McCormick@icfi.com)

**\*\*All comments submitted will become part of the Public Record**



Army Corp of Engineers  
California Department of Fish and Game

August 15, 2012

**RE: the Environmental Impact Report for the restoration of the Ballona Wetlands:**

**Gentlemen:**

**Please be advised that I oppose the opening of Ballona Creek and the use of the wetlands to sponge up the toxins in the creek.**

**I also oppose the dredging of the channel.**

**I support the completion of the study started in 2005 by the Army Corp of Engineers**

**I support a public hearing to discuss the findings of the Army Corp's completed report**

**I support the postponement of any Environmental Impact Study until the Army Corp's report is complete and the public has had time to digest it and discuss it in a public hearing.**

**I support the slow, natural restoration of the wetlands, preserving and enhancing the ecological niche for the native plants and animals and birds that have made it their home for centuries.**

**Wetlands are the nurseries for the Ocean and their loss is not just geographic, and visual,**

**I look forward to a public hearing on the restoration of the Ballona wetlands after the Army Corp report is completed and before the EIR is undertaken.**

**Cordially,**



**Ellen Brennan  
1659 Ocean Front Walk #102  
Santa Monica, Ca. 90401  
ellenbren@roadrunner.com**



# Ballona Wetlands Restoration Project

Advancing ecosystem health. Connecting communities with nature.

## Comment Card

Name: Carolyn Glassman

Email: (optional) lindsstar@aol.com

Add me to the mailing list (please provide email or mailing address): \_\_\_\_\_

Comments/Issues: (Use additional sheets if necessary)

Area C. East of Lincoln. Homeowner (not renter)

Concerns:

Regulation of car & foot traffic

Safety = too many (people w/ <sup>other</sup> homes) camping in area

= too many " " in State reserve

area who trash it: These include: dogs

dog walkers, bikers = pedal & motor, vagants  
drugs, disregard of authority, environment  
property, ecology, etc.

\* Concerned that plans may include opening La Villa Marina (St.)  
to the wetlands as a parking lot, entry to tours, etc.

(It do not let this happen. It will ruin our neighborhood  
and our right to enjoyment of our property.) Again - safety!

Please make communications between laymen (i.e. neighbors)  
and the "powers that be" - too many with many different interests, not  
necessarily beneficial. - a little more clear. Thank you

Submit written comments by **October 23, 2012** to:

Mail: Ballona Wetlands Restoration Project

Email: [Donna.McCormick@icfi.com](mailto:Donna.McCormick@icfi.com)

C/O Donna McCormick

1 Ada, Suite 100

Irvine, CA 92618

**\*\*All comments submitted will become part of the Public Record**



# Ballona Wetlands Restoration Project

Advancing ecosystem health. Connecting communities with nature.

## Comment Card

Name: Carolyn Glassman

Email: (optional) lindstar@aol.com

Add me to the mailing list (please provide email or mailing address): \_\_\_\_\_

Comments/Issues: (Use additional sheets if necessary)

Area C concerns (again.)  
specifically La Villa Rd line =  
no break-through to area C  
no 30 ft berms on the border  
of area C.

Comment card: 2/2 (Correct area reference is "C")

Submit written comments by October 23, 2012 to:

Mail: Ballona Wetlands Restoration Project  
C/O Donna McCormick  
1 Ada, Suite 100  
Irvine, CA 92618

Email: [Donna.McCormick@icfi.com](mailto:Donna.McCormick@icfi.com)

**\*\*All comments submitted will become part of the Public Record**

**From:** patricia mc pherson <patriciamcpherson1@verizon.net>  
**Subject:** Fwd: BALLONA WETLANDS Restoration; Public Process Thwarted  
**Date:** August 16, 2012 4:45:18 PM PDT

4 Attachments, 4.5 MB

Begin forwarded message:

**From:** patricia mc pherson <patriciamcpherson1@verizon.net>  
**Subject:** Fwd: BALLONA WETLANDS Restoration; Public Process Thwarted  
**Date:** August 16, 2012 4:44:05 PM PDT  
**To:** David Lawhead <DLawhead@dfg.ca.gov>, Director <Director@dfg.ca.gov>

Dear Misters Bonham and Lawhead,

As an initial response to the Ballona Wetlands EIR Scoping "Open House" Grassroots Coalition(GC) provides the following information with a request for response from the DFG. GC will provide further specific queries.

In a [DLawhead@dfg.ca.gov](mailto:DLawhead@dfg.ca.gov) email Aug. 15,2012 to John Davis--Mr. Lawhead states, "3. All comments received , either at the Scoping Meeting or by mail/email, are pooled together so that both Lead Agencies receive all the comments."

To whom is Mr. Lawhead referencing as LEAD AGENCIES?

It is GC's understanding that the Lead Agency is the DFG. Please provide any and all information as to legal status for a second LEAD Agency.

GC supports the RESOLUTION provided by the SIERRA CLUB.

GC believes that the current 'new NOI' process is contradictory to the 2005 JOINT EIS/EIR process that is supposed to be in process.

GC believes that the DFG has failed to perform as previously agreed and been a part of bond money expenditures while failing to comply with the 2005 JOINT EIS/EIR inclusive of the Feasibility Studies.

Why has the DFG failed to work in concert with the public and the Working Groups in an open and transparent process for ALTERNATIVE PLANNING?

Instead the DFG has participated in abrogating its duties of the 2005 JOINT EIS/EIR process and has worked to withhold Science Advisory Committee information to the public. The outcome of the DFG's failure to include the public in ALL REASONABLE ALTERNATIVES for restoration of Ballona has led to the singular outcome of "ESTUARINE" CREATION at Ballona and promotion of destruction of important safety levees built by USACE.

This destructive process proposed to reintroduce tidal flow to a freshwater wetland system that was not historically connected to the ocean to the degree the new process implies.

The singular "Alternative" that is illegitimately being forced upon the public also proposed to divert one Impaired Waterway into another. It is illegal to further impair a waterway (delineated wetland portion) into a waterway (seasonal wetland) that is already impaired. (CWA)

GC reserves its right to supply further comments and queries to the DFG regarding DFG's actions that may affect Ballona.

Thank you,  
Grassroots Coalition, Patricia McPherson-President

Begin forwarded message:

1 of 4  
A-44

**From:** patricia mc pherson <patriciamcpherson1@verizon.net>  
**Subject:** Fwd: BALLONA WETLANDS Restoration; Public Process Thwarted  
**Date:** August 16, 2012 7:51:53 AM PDT  
**To:** Scott Valor <svalor@santamonicabay.org>

**TO: ALL SANTA MONICA BAY RESTORATION COMMISSION- Commissioners & Alternates ;  
ALL BAY WATERSHED COUNCIL**

**% Scott Valor acting on behalf of SMBRC/BAY WATERSHED COUNCIL**

**C/O- Scott Valor is requested to send electronic copy of this message to all parties listed above.**

The parties listed above, in the past, have not received written comments delivered by the public and stakeholders at EITHER the SMBRC Governing Board Meetings and/or Executive Committee Meetings. The website for SMBRC has not posted, as requested, any and all public comments from the meetings. Written public comments delivered at the SMBRC Meetings have also had no response from SMBRC to the public. ( One GC query/comment letter had internal SMBRC intercommunication but was only rendered to the public via a Public Record Act request.) The failure by SMBRC to provide any and all public comments from these meetings to the parties listed above has created a disconnect of information between the public and this state agency that is contrary to the mission and goals of the this state agency.

**RE: SMBRC MEETING AUGUST 16, 2012 - PUBLIC COMMENT Pertaining to the Ballona Wetlands Restoration Process - A Failed Process By SMBRC**

**FROM: GRASSROOTS COALITION, Patricia McPherson-President**

Begin forwarded message:

**From:** patricia mc pherson <patriciamcpherson1@verizon.net>  
**Subject:** BALLONA WETLANDS Restoration; Public Process Thwarted  
**Date:** August 2, 2012 12:37:36 PM PDT  
**To:** [sschuchat@scc.ca.gov](mailto:sschuchat@scc.ca.gov), [dwayman@scc.ca.gov](mailto:dwayman@scc.ca.gov), [npateron@scc.ca.gov](mailto:npateron@scc.ca.gov), [carmen@scc.ca.gov](mailto:carmen@scc.ca.gov)  
**Cc:** [john.laird@resources.ca.gov](mailto:john.laird@resources.ca.gov), [john@scc.ca.gov](mailto:john@scc.ca.gov), [ana.matosantos@dof.ca.gov](mailto:ana.matosantos@dof.ca.gov), [billrosendahl@aol.com](mailto:billrosendahl@aol.com), [bill.lockyer@treasurer.ca.gov](mailto:bill.lockyer@treasurer.ca.gov), [jeanne.h.imamura@usace.army.mil](mailto:jeanne.h.imamura@usace.army.mil), [hamilton.cloud@mail.gov](mailto:hamilton.cloud@mail.gov), [adolfo.bailon@boxer.senate.gov](mailto:adolfo.bailon@boxer.senate.gov), [michael.davies@feinstein.senate.gov](mailto:michael.davies@feinstein.senate.gov), Kulla Norman <[norman.kulla@lacity.org](mailto:norman.kulla@lacity.org)>

To: Coastal Conservancy  
Attn: All Governing Board Members and Alternates

From: Grassroots Coalition, Patricia McPherson, President

RE: Complaint and Request re: Support to the J. Davis 3/29/12 REQUEST TO RESCIND APPROVAL FOR STAFF RECOMMENDATION APPROVAL ON 1/19/12 awarding \$6,490.00. for: FILE NO. 04-088-BALLONA WETLANDS RESTORATION ENGINEERING AND TECHNICAL STUDIES

and,  
Request for the Coastal Conservancy to stop its interference in the approved and ongoing 2005 Joint EIS/EIR process regarding restoration of the Ballona Wetlands Ecological Preserve.

Respectfully submitted,  
Patricia McPherson, Grassroots Coalition

  
ADDITIONAL...docx (179 KB)

  
CA CONSER...pdf (1.2 MB)

2 of 4



DEPARTMENT OF THE ARMY  
OFFICE OF THE ASSISTANT SECRETARY  
CIVIL WORKS  
108 ARMY PENTAGON  
WASHINGTON DC 20310-0108

MAY 30 2012

Mr. John Davis  
P.O. Box 10152  
Marina Del Rey, California 90295

Dear Mr. Davis:

I have been asked to respond on behalf of Secretary of the Army John M. McHugh to your May 11, 2012, correspondence concerning the Marina del Rey Harbor project and the Ballona Creek, California Ecosystem Restoration feasibility study (Ballona Creek study). The Marina del Rey Harbor entrance channel is a Federal navigation project; however the side channels, docks and inner harbor facilities are not a Federal responsibility and are maintained by the Los Angeles County Department of Beaches and Harbors.

The Ballona Creek study is under development by the Los Angeles District of the Army Corps of Engineers (Corps). You asked about the status of the study, the non-federal cost sharing, and the environmental impact statement. The Ballona Creek study is an ongoing feasibility study examining restoration options for coastal wetlands and lagoons. The study and the environmental impact statement have not been finalized, and very limited federal funding is available to continue them. The non-federal sponsor, the Santa Monica Bay Restoration Commission (SMBRC), has provided its share of the study costs through in-kind services, subject to a Corps evaluation and final approval of crediting. Discussions with the SMBRC on the future of the study have been initiated.

If you would like additional details on the Marina del Rey project or the Ballona Creek study, you may wish to contact Mr. Steve Dwyer, Chief, Navigation Branch, Los Angeles District at (213) 452-3385.

Very truly yours,

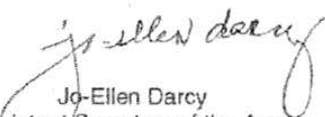
  
Jo-Ellen Darcy  
Assistant Secretary of the Army  
(Civil Works)

3 of 4



REPLY TO  
ATTENTION OF

**DEPARTMENT OF THE ARMY**

LOS ANGELES DISTRICT CORPS OF ENGINEERS  
P.O. BOX 432711  
LOS ANGELES, CALIFORNIA 90083-2325

June 19, 2012



Office of  
District Counsel

John Davis  
PO Box 10152  
Marina Del Rey, CA 90295

RE: Ballona Wetlands

Dear Mr. Davis,

This letter concerns your Freedom of Information Act (FOIA) request dated May 3, 2012. Your request, assigned number FA-12-0109, is enclosed. Please use this reference number in any further correspondence regarding this request.

In your letter, you requested documents related to the Ballona Wetlands, specifically:

- 1) Any and all documents terminating the Environmental Impact Statement process undertaken by the Corps.
- 2) Any and all information regarding financial records of the aforesaid process inclusive of all expenditures of money by the Corps and all money received by the Corps for the same purpose from any source whatsoever.
- 3) Any and all information terminating the local sponsor agreement entered into for the aforesaid purpose between the Corps and the local sponsor, the Santa Monica Bay Restoration Authority.

We have conducted our search and no responsive documents exist due to the following reasons:

- 1) The Environmental Impact Statement process has not been formally terminated.
- 2) There have been no expenditures with regard to a formal termination.
- 3) The local sponsor agreement has not been terminated.

The Program Manager does not anticipate that the EIS process will be terminated in the near future.



4 of 4



# Ballona Wetlands Restoration Project

*Advancing ecosystem health. Connecting communities with nature.*

## Comment Card

Name: ADAM KUSZEWSKI

Email: (optional) adamkles@hotmail.com

Add me to the mailing list (please provide email or mailing address): \_\_\_\_\_

Comments/Issues: (Use additional sheets if necessary) \_\_\_\_\_

I AM ~~HEARING~~ READING CONFLICTING INFO ABOUT  
THE SOUNDNESS OF CURRENT PLANS AND WOULD  
CERTAINLY SUPPORT AN OPEN PERIOD OF  
INFORMING THE NEIGHBORS.

I AM MAINLY CONCERNED WITH THE PRESERVATION  
OF ECOLOGICAL VALUES INHERENT IN THE WETLANDS

Submit written comments by **October 23, 2012** to:

Mail: Ballona Wetlands Restoration Project

C/O Donna McCormick

1 Ada, Suite 100

Irvine, CA 92618

Email: [Donna.McCormick@icfi.com](mailto:Donna.McCormick@icfi.com)

**\*\*All comments submitted will become part of the Public Record**





# Ballona Wetlands Restoration Project

Advancing ecosystem health. Connecting communities with nature.

## Comment Card

Name: Michael Lutz

Email: (optional) MickeyLutz@gmail.com

Add me to the mailing list (please provide email or mailing address): \_\_\_\_\_

Comments/Issues: (Use additional sheets if necessary)

- 1) There has been a LACK OF INFORMATION regarding the need for the project. I'm wondering if the desire to restore ecosystem functions is a desire to turn out wetlands into a stormwater management plant. This relates to another concern:
- 2) That the current plan is to connect the creek to the wetlands. What will be the impact of this sensitive ecosystem receiving polluted waters from the city?
- 3) I am concerned about the fact that the plan is to remove stable and important aspects of the wetlands. In general, it seems that the plan is to engineer a wetlands, as opposed to working with the natural features of the land. Constant dredging to maintain an open tidal system is a) not consistent with "restoration" and not an expense that tax payers should undertake.

Submit written comments by **October 23, 2012** to:

Mail: Ballona Wetlands Restoration Project  
C/O Donna McCormick  
1 Ada, Suite 100  
Irvine, CA 92618

Email: [Donna.McCormick@icfi.com](mailto:Donna.McCormick@icfi.com)

**\*\*All comments submitted will become part of the Public Record**

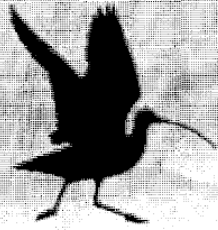

# Ballona Wetlands Restoration Project

Advancing ecosystem health. Connecting communities with nature.

## Comment Card

Name: \_\_\_\_\_

Email: (optional) \_\_\_\_\_

Add me to the mailing list (please provide email or mailing address): \_\_\_\_\_

Comments/Issues: (Use additional sheets if necessary)

Overall, the rapidity by which this project is being pushed through, the lack of information, the inadequacy of the plan, the lack of a PUBLIC HEARING is

Very concerning to me.

Submit written comments by October 23, 2012 to:

Mail: Ballona Wetlands Restoration Project  
C/O Donna McCormick  
1 Ada, Suite 100  
Irvine, CA 92618

Email: [Donna.McCormick@icfi.com](mailto:Donna.McCormick@icfi.com)

**\*\*All comments submitted will become part of the Public Record**

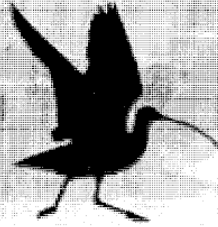

# Ballona Wetlands Restoration Project

Advancing ecosystem health. Connecting communities with nature.

## Comment Card

Name: Ingrid Mueller

Email: (optional) ingridmueller@yahoo.com

Add me to the mailing list (please provide email or mailing address): \_\_\_\_\_

Comments/Issues: (Use additional sheets if necessary) We NEED :

2 x Public Sit-Down Meetings  
@ Convenient Times & Locations  
that are TRANSPARENT!

Extension is NEEDED for 90 days

Protest Signs : | LEAVE BALLONA ALONE!  
TO HELP NATURE

NOT ANOTHER  
MALIBU LAGOON  
DISASTER

NO BULLDOZING OF  
NATURE

LET FISH + BIRDS + FAUNA  
BE

Submit written comments by October 23, 2012 to:

Mail: Ballona Wetlands Restoration Project  
C/O Donna McCormick  
1 Ada, Suite 100  
Irvine, CA 92618

Email: [Donna.McCormick@icfi.com](mailto:Donna.McCormick@icfi.com)

**\*\*All comments submitted will become part of the Public Record**

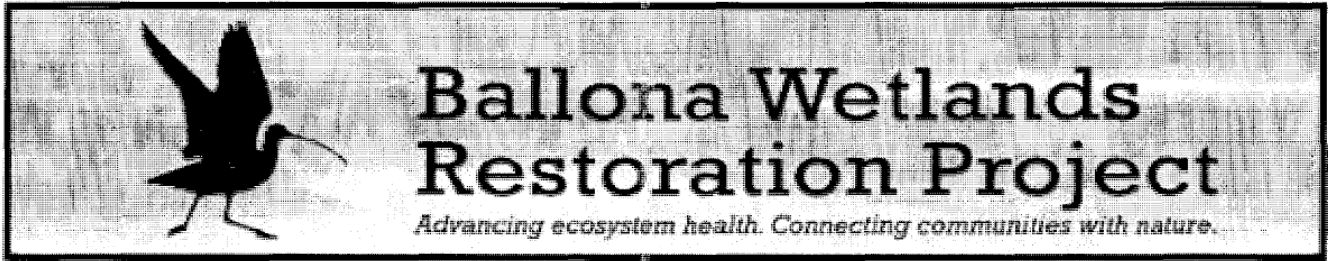

### Comment Card

Name: Elizabeth Pollock

Email: (optional) president@delreyhome.org

Add me to the mailing list (please provide email or mailing address): \_\_\_\_\_

Comments/Issues: (Use additional sheets if necessary)

I am president of the Del Rey Residents Association. Del Rey is the neighborhood east of Lincoln Blvd. between Jefferson Blvd + Washington Blvd. It is part of the City of Los Angeles.

On August 6, 2012, the MRCA's Ana Petric told us that the new Milton Street Park would have no new trees added because the Army Corps of Engineers was concerned that the tree roots might damage the levee. Therefore, I assume that there will be opposition to any proposal to remove the levee.

Also, my family has lived in Venice since the 1890's and I was raised by people who remember the 1938 flood that led to construction of the concrete levee. In 1938, Lincoln Blvd. became impassable. Any restoration project must provide for adequate stormwater management.

Submit written comments by **October 23, 2012** to:

Mail: Ballona Wetlands Restoration Project  
C/O Donna McCormick  
1 Ada, Suite 100  
Irvine, CA 92618

Email: [Donna.McCormick@icfi.com](mailto:Donna.McCormick@icfi.com)

***\*\*All comments submitted will become part of the Public Record***



# Ballona Wetlands Restoration Project

Advancing ecosystem health. Connecting communities with nature.

## Comment Card

Name: Al Sattler

Email: (optional) asattler@igc.org

Add me to the mailing list (please provide email or mailing address): \_\_\_\_\_

Comments/Issues: (Use additional sheets if necessary) \_\_\_\_\_

Mineral Rights?

Are the mineral rights owned by the State of California?

Or is there any possibility ~~is~~ that mineral rights have been retained by an oil company, which could do drilling / fracking without notice?

Plan for sea level rise

Submit written comments by October 23, 2012 to:

Mail: Ballona Wetlands Restoration Project  
C/O Donna McCormick  
1 Ada, Suite 100  
Irvine, CA 92618

Email: [Donna.McCormick@icfi.com](mailto:Donna.McCormick@icfi.com)

**\*\*All comments submitted will become part of the Public Record**



**SIERRA  
CLUB**  
FOUNDED 1892

Angeles Chapter  
Airport Marina Regional Group  
3435 Wilshire Blvd., Ste. 320  
Los Angeles, CA 90010

August 16, 2012

**U.S. Army Corps of Engineers**

Los Angeles District  
915 Wilshire Blvd, Suite 1101  
Los Angeles, CA 90017  
Att: Col. Mark Toy Commander Los Angeles District  
Att: Dr. Daniel P. Swenson  
1416 9th St., 12th Floor

**California Dept. of Fish & Game**

1416 9th Street, 12th Floor  
Sacramento, CA 95814  
Att: Executive Director Charlton H. Bonham

Re: 2012 Notice of Joint EIS/EIR

This letter responds to the Notice of Intent to conduct a joint EIS/EIR pursuant to the National Environmental Policy Act and the California Environmental Protection Act at the Ballona Wetlands Ecological Preserve in the State of California, County of Los Angeles, in 2012.

The Club has resolved to support the joint EIR/EIS process noticed in the Federal Register on September 20, 2005 by the U.S. ACE Los Angeles District and the Santa Monica Bay Restoration Commission, a State Agency, as the local sponsor.

The position of the Club is that the new Notice of Intent placed in the Federal Register on July 25, 2012 contradicts and duplicates the former EIS noticed in 2005.

The Secretary of the Army has stated in writing that the 2005 joint EIS/EIR process is not terminated and is therefore current.

The reasoning of the resolution is as follows:

Another EIS process has been introduced by LA USACE that interferes with and contradicts the current process. The Corp has begun a new process that duplicates and reduces the scope of the 2005 Environmental Process, without first terminating it.

The two processes cannot exist concurrently, because of duplication, and the requirement for the first study to be completed. The first study has been fully funded by the U.S. Congress and the latter process has not.

The second process proposes to change the course of Ballona Creek, and to dredge and fill wetlands, prior to the completion of the first process and before the Corp can report its recommendations back to Congress.

Furthermore, the second process proposes to reintroduce tidal flow to a freshwater wetland system that was not historically connected to the ocean to the degree the new process implies.

The National Oceanic and Atmospheric Administration warned against this project, as it would destroy valuable upland habitat.

The U.S. Clean Water Act designates four separate Section 303(d) Impaired Waterways that are present.

- Marina del Rey
- Upper Ballona Creek
- Ballona Creek Estuary
- Ballona Wetlands

The 2012 Notice proposes to divert one Impaired Waterway into another. It is illegal to further impair a waterway that is already impaired.

The resolution reads as follows and represents the Sierra Club official stance on both of the aforesaid environmental processes.

**RESOLUTION**

*Whereas, the Airport Marina Regional Group of the Angeles Chapter Sierra Club has jurisdiction over Marina del Rey,*

*Whereas, The Club supports National Planning for Environmental Restoration, Recreational Boating, Storm Damage Reduction, and is Supportive of other purposes the Congress of the United States intended for Marina del Rey such as a youth hostel and camping facilities.*

*Whereas, The U.S. Army Corp of Engineers Environmental Impact Statement process noticed in the Federal Register in 2005 supports the same aforesaid purposes that the Sierra Club supports,*

*Therefore, be it resolved by the Airport Marina Regional Group, Angeles Chapter of Sierra Club, supports the completion of the 2005 Environmental Review process Noticed in the Federal Register to conduct a review of Marina del Rey: September 20, 2005 (Volume 70, Number 181) [Notices] [Page 55116-55117]*

END

The Sierra Club supports a full range of alternatives for the restoration, which is called for in the 2005 Notice for Environmental Impact Statement pursuant to the National Environmental Policy Act. The Sierra Club does not support a limited range of alternatives as proposed by the 2012 Notice for an Environmental Impact Statement.

Sincerely,



Joe Young, Chair  
Airport Marina Group  
(310) 822-9676





**SIERRA  
CLUB**  
FOUNDED 1892

Angeles Chapter  
Airport Marina Regional Group  
3435 Wilshire Blvd., Ste. 320  
Los Angeles, CA 90010

August 16, 2012

**U.S. Army Corps of Engineers**

Los Angeles District  
915 Wilshire Blvd, Suite 1101  
Los Angeles, CA 90017  
Att: Col. Mark Toy Commander Los Angeles District  
Att: Dr. Daniel P. Swenson  
1416 9th St., 12th Floor

**California Dept. of Fish & Game**

1416 9th Street, 12th Floor  
Sacramento, CA 95814  
Att: Executive Director Charlton H. Bonham

Re: 2012 Notice of Joint EIS/EIR

This letter responds to the Notice of Intent to conduct a joint EIS/EIR pursuant to the National Environmental Policy Act and the California Environmental Protection Act at the Ballona Wetlands Ecological Preserve in the State of California, County of Los Angeles, in 2012.

The Club has resolved to support the joint EIR/EIS process noticed in the Federal Register on September 20, 2005 by the U.S. ACE Los Angeles District and the Santa Monica Bay Restoration Commission, a State Agency, as the local sponsor.

The position of the Club is that the new Notice of Intent placed in the Federal Register on July 25, 2012 contradicts and duplicates the former EIS noticed in 2005.

The Secretary of the Army has stated in writing that the 2005 joint EIS/EIR process is not terminated and is therefore current.

The reasoning of the resolution is as follows:

Another EIS process has been introduced by LA USACE that interferes with and contradicts the current process. The Corp has begun a new process that duplicates and reduces the scope of the 2005 Environmental Process, without first terminating it.

The two processes cannot exist concurrently, because of duplication, and the requirement for the first study to be completed. The first study has been fully funded by the U.S. Congress and the latter process has not.

The second process proposes to change the course of Ballona Creek, and to dredge and fill wetlands, prior to the completion of the first process and before the Corp can report its recommendations back to Congress.

Furthermore, the second process proposes to reintroduce tidal flow to a freshwater wetland system that was not historically connected to the to the ocean to the degree the new process implies.

The National Oceanic and Atmospheric Administration warned against this project, as it would destroy valuable upland habitat.

The U.S. Clean Water Act designates four separate Section 303(d) Impaired Waterways that are present.

- Marina del Rey
- Upper Ballona Creek
- Ballona Creek Estuary
- Ballona Wetlands

The 2012 Notice proposes to divert one Impaired Waterway into another. It is illegal to further impair a waterway that is already impaired.

The resolution reads as follows and represents the Sierra Club official stance on both of the aforesaid environmental processes.

**RESOLUTION**

*Whereas, the Airport Marina Regional Group of the Angeles Chapter Sierra Club has jurisdiction over Marina del Rey,*

*Whereas, The Club supports National Planning for Environmental Restoration, Recreational Boating, Storm Damage Reduction, and is Supportive of other purposes the Congress of the United States intended for Marina del Rey such as a youth hostel and camping facilities.*

*Whereas, The U.S. Army Corp of Engineers Environmental Impact Statement process noticed in the Federal Register in 2005 supports the same aforesaid purposes that the Sierra Club supports,*

*Therefore, be it resolved by the Airport Marina Regional Group, Angeles Chapter of Sierra Club, supports the completion of the 2005 Environmental Review process Noticed in the Federal Register to conduct a review of Marina del Rey: September 20, 2005 (Volume 70, Number 181) [Notices] [Page 55116-55117]*

END

The Sierra Club supports a full range of alternatives for the restoration, which is called for in the 2005 Notice for Environmental Impact Statement pursuant to the National Environmental Policy Act. The Sierra Club does not support a limited range of alternatives as proposed by the 2012 Notice for an Environmental Impact Statement.

Sincerely,

  
Joe Young, Chair  
Airport Marina Group  
(310) 822-9676



4712 Admiralty Way, #156  
Marina del Rey, California  
90292 USA

Phone: 310.397.3114  
Mobile: 310.418.1754  
Fax: 310.862.6708  
deana@aquabio.us  
www.aquabio.us

DeAna Vitela-Hayashi | Director

**Congress of the United States**  
**House of Representatives**  
**Washington, DC 20515-0536**

July 31, 2012

The Honorable Jo-Ellen Darcy  
Assistant Secretary of the Army (Civil Works)  
108 Army Pentagon  
Washington, DC 20310-0108

Dear Secretary Darcy,

I write in regards to an issue relating to the proposed Ballona Wetlands restoration project in Los Angeles, California.

It has come to my attention that members of the community are concerned that the announced comment period for scoping the Environmental Impact Statement/Environmental Impact Report will be too short to allow for full comment from the relevant experts and community members. With so much of the comment period falling during peak summer vacation months, the September 10, 2012 deadline might unintentionally diminish the quality of these important assessments.

The community must be able to have trust in the scope of the EIS/EIR so that they can confidently assess the right way to preserve and restore the Ballona Wetlands. As such, I urge you to extend the public comment period on scoping to 90 days, and to convene a public hearing at a time and place convenient for interested community members to make their voices heard.

Sincerely,



Janice Hahn  
Member of Congress

**NATIVE AMERICAN HERITAGE COMMISSION**

915 CAPITOL MALL, ROOM 364  
SACRAMENTO, CA 95814  
(916) 653-6251  
Fax (916) 657-5390  
Web Site [www.nahc.ca.gov](http://www.nahc.ca.gov)  
ds\_nahc@pacbell.net



August 2, 2012

Mr. David Lawhead, Project Planner

**California Department of Fish & Game**

3883 Ruffin Road  
San Diego, CA 92123

Re: SCH#2012071090 CEQA Notice of Preparation (NOP); draft Environmental Impact Report (DEIR) for the Ballona Wetlands Restoration Project; The Ballona Wetlands Ecological Reserve is located in the western portion of the City of Los Angeles (partially within unincorporated Los Angeles County), south of The City of Marina Del Rey and north of Playa Del Rey; approximately 1.5 miles west of Interstate 405 and approximately 0.25 miles east of Santa Monica Bay; Los Angeles County, California.

Dear Mr. Lawhead:

The Native American Heritage Commission (NAHC), the State of California 'Trustee Agency' for the protection and preservation of Native American cultural resources pursuant to California Public Resources Code §21070 and affirmed by the Third Appellate Court in the case of EPIC v. Johnson (1985: 170 Cal.App. 3<sup>rd</sup> 604).

This letter includes state and federal statutes relating to Native American historic properties or resources of religious and cultural significance to American Indian tribes and interested Native American individuals as 'consulting parties' under both state and federal law. State law also addresses the freedom of Native American Religious Expression in Public Resources Code §5097.9. This project is also subject to California Government Code Section 65352.3 *et seq.*

The California Environmental Quality Act (CEQA – CA Public Resources Code 21000-21177; amendments effective 3/18/2010) requires that any project that causes a substantial adverse change in the significance of an historical resource, that includes archaeological resources, is a 'significant effect' requiring the preparation of an Environmental Impact Report (EIR) per the CEQA Guidelines defines a significant impact on the environment as 'a substantial, or potentially substantial, adverse change in any of physical conditions within an area affected by the proposed project, including ... objects of historic or aesthetic significance.' In order to comply with this provision, the lead agency is required to assess whether the project will have an adverse impact on these resources within the 'area of potential effect (APE); and if so, to mitigate that effect. The NAHC did conduct a Sacred Lands File search of the project site, therefore 'area of potential effect' or APE, and Native American cultural resources were identified within the APE.

The NAHC "Sacred Sites," as defined by the Native American Heritage Commission and the California Legislature in California Public Resources Code §§5097.94(a) and 5097.96. Items in

the NAHC Sacred Lands Inventory are confidential and exempt from the Public Records Act pursuant to California Government Code §6254 (r).

Early consultation with Native American tribes in your area is the best way to avoid unanticipated discoveries of cultural resources or burial sites once a project is underway. Culturally affiliated tribes and individuals may have knowledge of the religious and cultural significance of the historic properties in the project area (e.g. APE). We strongly urge that you make contact with the list of Native American Contacts on the attached list of Native American contacts, to see if your proposed project might impact Native American cultural resources and to obtain their recommendations concerning the proposed project. Pursuant to CA Public Resources Code § 5097.95, the NAHC requests cooperation from other public agencies in order that the Native American consulting parties be provided pertinent project information. Consultation with Native American communities is also a matter of environmental justice as defined by California Government Code §65040.12(e). Pursuant to CA Public Resources Code §5097.95, the NAHC requests that pertinent project information be provided consulting tribal parties, including archaeological studies. The NAHC recommends *avoidance* as defined by CEQA Guidelines §15370(a) to pursuing a project that would damage or destroy Native American cultural resources and Section 2183.2 that requires documentation, data recovery of cultural resources.

Furthermore, the NAHC if the proposed project is under the jurisdiction of the statutes and regulations of the National Environmental Policy Act (e.g. NEPA; 42 U.S.C. 4321-43351). Consultation with tribes and interested Native American consulting parties, on the NAHC list, should be conducted in compliance with the requirements of federal NEPA and Section 106 and 4(f) of federal NHPA (16 U.S.C. 470 *et seq*), 36 CFR Part 800.3 (f) (2) & .5, the President's Council on Environmental Quality (CSQ, 42 U.S.C 4371 *et seq.* and NAGPRA (25 U.S.C. 3001-3013) as appropriate. The 1992 *Secretary of the Interiors Standards for the Treatment of Historic Properties* were revised so that they could be applied to all historic resource types included in the National Register of Historic Places and including cultural landscapes. Also, federal Executive Orders Nos. 11593 (preservation of cultural environment), 13175 (coordination & consultation) and 13007 (Sacred Sites) are helpful, supportive guides for Section 106 consultation. The aforementioned Secretary of the Interior's *Standards* include recommendations for all 'lead agencies' to consider the historic context of proposed projects and to "research" the cultural landscape that might include the 'area of potential effect.'

Confidentiality of "historic properties of religious and cultural significance" should also be considered as protected by California Government Code §6254( r) and may also be protected under Section 304 of he NHPA or at the Secretary of the Interior discretion if not eligible for listing on the National Register of Historic Places. The Secretary may also be advised by the federal Indian Religious Freedom Act (cf. 42 U.S.C., 1996) in issuing a decision on whether or not to disclose items of religious and/or cultural significance identified in or near the APEs and possibility threatened by proposed project activity.

Furthermore, Public Resources Code Section 5097.98, California Government Code §27491 and Health & Safety Code Section 7050.5 provide for provisions for inadvertent discovery of human remains mandate the processes to be followed in the event of a discovery of human remains in a project location other than a 'dedicated cemetery'.

To be effective, consultation on specific projects must be the result of an ongoing relationship between Native American tribes and lead agencies, project proponents and their contractors, in the opinion of the NAHC. Regarding tribal consultation, a relationship built

around regular meetings and informal involvement with local tribes will lead to more qualitative consultation tribal input on specific projects.

Finally, when Native American cultural sites and/or Native American burial sites are prevalent within the project site, the NAHC recommends 'avoidance' of the site as referenced by CEQA Guidelines Section 15370(a).

If you have any questions about this response to your request, please do not hesitate to contact me at (916) 653-6251.

Sincerely,

  
Dave Singleton  
Program Analyst

Cc: State Clearinghouse

Attachment: Native American Contact List



**Native American Contact**  
Los Angeles County  
August 2, 2012

LA City/County Native American Indian Comm  
Ron Andrade, Director  
3175 West 6th St, Rm. 403  
Los Angeles , CA 90020  
randrade@css.lacounty.gov  
(213) 351-5324  
(213) 386-3995 FAX

Gabrielino Tongva Nation  
Sam Dunlap, Chairperson  
P.O. Box 86908  
Los Angeles , CA 90086  
samdunlap@earthlink.net  
Gabrielino Tongva  
(909) 262-9351 - cell

Ti'At Society/Inter-Tribal Council of Pimu  
Cindi M. Alvitre, Chairwoman-Manisar  
3094 Mace Avenue, Apt. B Gabrielino  
Costa Mesa, , CA 92626  
calvitre@yahoo.com  
(714) 504-2468 Cell

Gabrielino Tongva Indians of California Tribal Council  
Robert F. Dorame, Tribal Chair/Cultural Resources  
P.O. Box 490  
Bellflower , CA 90707  
gtongva@verizon.net  
Gabrielino Tongva  
562-761-6417 - voice  
562-761-6417- fax

Tongva Ancestral Territorial Tribal Nation  
John Tommy Rosas, Tribal Admin.  
Private Address Gabrielino Tongva  
**tattnlaw@gmail.com**  
310-570-6567

Gabrielino-Tongva Tribe  
Bernie Acuna  
1875 Century Pk East #1500 Gabrielino  
Los Angeles , CA 90067  
(619) 294-6660-work  
(310) 428-5690 - cell  
(310) 587-0170 - FAX  
bacuna1@gabrieinotribe.org

Gabrieleno/Tongva San Gabriel Band of Mission  
Anthony Morales, Chairperson  
PO Box 693 Gabrielino Tongva  
San Gabriel , CA 91778  
GTTribalcouncil@aol.com  
(626) 286-1632  
(626) 286-1758 - Home  
(626) 286-1262 -FAX

Gabrielino-Tongva Tribe  
Linda Candelaria, Chairwoman  
1875 Century Pk East #1500 Gabrielino  
Los Angeles , CA 90067  
lcandelaria1@gabrielinoTribe.org  
626-676-1184- cell  
(310) 587-0170 - FAX

This list is current only as of the date of this document.

Distribution of this list does not relieve any person of the statutory responsibility as defined in Section 7050.5 of the Health and Safety Code, Section 5097.94 of the Public Resources Code and Section 5097.98 of the Public Resources Code.

This list is applicable for contacting local Native Americans with regard to cultural resources for the proposed SCH#2012071090; CEQA Notice of Preparation (NOP); draft Environmental Impact Report (DEIR) for the Ballona Wetlands Restoration Project; located near the City of Marina Del Rey and Santa Monica Bay and part of the Ballona Creek watershed; Los Angeles County, California .

**Native American Contact**  
Los Angeles County  
August 2, 2012

Santa Ynez Tribal Elders Council  
Freddie Romero, Cultural Preservation ConsInt  
P.O. Box 365 Chumash  
Santa Ynez , CA 93460  
freddyromero1959@yahoo.  
805-688-7997, Ext 37

Gabrieleno Band of Mission Indians  
Andrew Salas, Chairperson  
P.O. Box 393 Gabrielino  
Covina , CA 91723  
(626) 926-4131  
gabrielenoindians@yahoo.  
com

This list is current only as of the date of this document.

Distribution of this list does not relieve any person of the statutory responsibility as defined in Section 7050.5 of the Health and Safety Code, Section 5097.94 of the Public Resources Code and Section 5097.98 of the Public Resources Code.

This list is applicable for contacting local Native Americans with regard to cultural resources for the proposed SCH#2012071090; CEQA Notice of Preparation (NOP); draft Environmental Impact Report (DEIR) for the Ballona Wetlands Restoration Project; located near the City of Marina Del Rey and Santa Monica Bay and part of the Ballona Creek watershed; Los Angeles County, California .

**Jones, Tanya**

---

**Subject:** RE: ACE and Del Rey Lagoon (UNCLASSIFIED)

-----Original Message-----

From: Wm. Ballough [<mailto:williamb7@Verizon.net>]

Sent: Thursday, August 02, 2012 6:02 PM

To: Swenson, Daniel P SPL

Cc: Julie Inouye; [beverlyponder@verizon.net](mailto:beverlyponder@verizon.net); 'Eric Andres'

Subject: ACE and Del Rey Lagoon

I understood that ACES was originally asked to include Del Rey Lagoon in the study, is not to be included. As you know, the corps cut the lagoon off from the creek in connection with its channelization. The local ACE office was very helpful to me in my study of the lagoon's history.

ACE needed use of the north bank of the lagoon to dredge and improve the creek. Because the land beneath its waters were privately owned, it apparently filled the north end in exchange for the right to bring its dredge across it, and to dispose of dredgings. The lagoon was also used during that period for the wholesale dumping of construction debris around its banks.

For the next 20 years the lagoon was used for children boating instruction. However, it silted up and became unusable for boating. With the silting came the unsightly and odiferous algae. The surrounding streets drain into the lagoon. The city has mentioned a possible clean water project to mitigate runoff, but has not addressed the major lagoon street drain at 63rd and Pacific. That drain floods electrical vaults in the street and incidentally, corroded my underground electrical service breakers, and the debris no doubt ended up in the lagoon.

Because of its silted condition the lagoon needs to be dredged, which could be done in connection with the wetland dredging.

Is there a possibility that the lagoon could still be included in the ACE study?

Classification: UNCLASSIFIED

Caveats: NONE

**From:** [Howard Hackett](#)  
**To:** [McCormick, Donna](#)  
**Subject:** Ballona wetlands Restoration Project  
**Date:** Friday, August 03, 2012 4:46:18 PM

---

Donna McCormick,  
Per my input on the restoration project

Ballona Wetlands Restoration Project

C/O Donna McComick

1 Ada, Suite 100  
Irvine, CA 92816

Dear Donna McCormick

My name is Howard Hackett. I have been a resident of the area for my whole life. The last decade I have been an active member of the Ballona Creek Watershed Task Force. During this time I have had the opportunity to see all kinds of folks in all kind of actions. I might add, that much that has gone on in this task force has been negative. Although I will not name names from all the negative forces, I will express my opinion that most of this negativity comes from folks that don't have complete knowledge of the goals. The opinions of these diverse groups lead me to believe that "their" convictions lead to self gratification on what the project can do for them, and not the benefit of the whole. "It is my way or it is wrong"

They try so many stupid tricks to make their points, that the goals of any project is lost. We have heard so many stories of killed "cute" creatures crossing streets.

Therefore, all projects are delayed, because of law suits etc, or threatened suits that eat up precious time and energy that we never see any positive results. My one suggestion is to listen to these "extreme" experts only one short time, then get on with the project.

Thank you for listening

[Howard Hackett](#)

*When I see an adult on a bicycle, I do not  
despair for the future of the human race!!  
H.G. Wells*

**Jones, Tanya**

---

---

**From:** Anita Gutierrez [<mailto:agutierrez@planning.lacounty.gov>]

**Sent:** Tuesday, August 07, 2012 5:08 PM

**To:** McCormick, Donna

**Subject:** Ballona Wetlands Project

Hi Donna,

Can you please add me to the mailing list to receive information on this project. Thanks so much. Contact information listed below

-----  
**Anita Gutierrez**  
**Special Projects Section**  
**Department of Regional Planning**  
**320 W. Temple Street**  
**Los Angeles, CA 90012**  
**(213) 974-4813**

**Jones, Tanya**

---

-----Original Message-----

From: Swenson, Daniel P SPL [<mailto:Daniel.P.Swenson@usace.army.mil>]  
Sent: Monday, August 13, 2012 11:31 AM  
To: Susan Herrschaft  
Cc: McCormick, Donna; Diana Hurlbert  
Subject: RE: Ballona DEIS/EIR Information (UNCLASSIFIED)

Classification: UNCLASSIFIED  
Caveats: NONE

Sue,

Other than our public notice mailing list (you can sign up for LA County public notices at our website below), we don't maintain a distribution list for specific projects. I am cc'ing the applicant's agent who can add you to whatever lists they maintain.

sincerely,

Daniel P. Swenson, D.Env.  
Chief, LA & San Bernardino Counties Section U.S. Army Corps of Engineers  
Attn: Regulatory Division  
915 Wilshire Blvd.  
Los Angeles, CA 90017

213-452-3414  
213-452-4196 fax  
<http://www.spl.usace.army.mil/Missions/Regulatory.aspx>

Assist us in better serving you!  
You are invited to complete our customer survey, located at the following link: <http://per2.nwp.usace.army.mil/survey.html>

Note: If the link is not active, copy and paste it into your internet browser.

-----Original Message-----

From: Susan Herrschaft [<mailto:sherrschaft@yahoo.com>]  
Sent: Monday, August 13, 2012 10:41 AM  
To: Swenson, Daniel P SPL  
Subject: Ballona DEIS/EIR Information

Hello Daniel,

I understand you are the person to contact to be placed on the mailing list for information regarding the upcoming DEIS/EIR for Ballona. I plan on attending the scoping meeting this week, but wanted to make sure I could receive any additional information that is distributed.

I am a resident of the Villa Marina neighborhood directly adjacent to Ballona Area C. I am looking forward to learning more about the project and offering our perspective.

If you would add my email address to the list, I would greatly appreciate it.

Thank you,  
Sue Herrschaft  
[sherrschaft@yahoo.com](mailto:sherrschaft@yahoo.com)

Classification: UNCLASSIFIED  
Caveats: NONE

**Jones, Tanya**

---

**Subject:** RE: Ballona " Restoration"-My property continuous with Area B

**From:** Colleen Phillips [<mailto:cpmax82@hotmail.com>]

**Sent:** Monday, August 13, 2012 7:31 PM

**To:** Elena Tuttle

**Subject:** Ballona " Restoration"-My property continuous with Area B

Today is Aug 14th and I have just found out about the scoping meeting on the 16th. I have to work that evening and I am amazed that ,at the very least, people who's property is continuous with the project were not informed about the meeting a month ago . This can only be an effort to jam the project through without public input ! I may now have to be the front for a lawsuit ! This time frame is soooooo outrageous !

Colleen Phillips  
8100 Billowvista Drive  
Playa Del Rey, Ca



**Jones, Tanya**

---

**Subject:** RE: Ballona Wetlands Restoration Plan DRAFT EIR re-submission letter - Vista del Mar Neighbors Association of Playa del Rey

-----Original Message-----

From: Julie Inouye [<mailto:julieinouye@me.com>]

Sent: Monday, August 13, 2012 9:04 AM

To: Shelley Luce; McCormick, Donna

Cc: Bill Rosendahl; Michael Bonin; NATE KAPLAN

Subject: Ballona Wetlands Restoration Plan DRAFT EIR re-submission letter - Vista del Mar Neighbors Association of Playa del Rey

Dear Shelley & Donna,

Please find a copy of the scanned pdf letter from the Vista del Mar Neighbors Association of Playa del Rey. This letter was originally sent to Fish & Games in 2009, when they were requesting input from the community for the BW Restoration. The letter to Fish and Games is the same letter we would write today, in 2012, so please take this as our letter on record of 8/2012.

We are submitting this same letter to be a part of the preliminary outline of the Draft EIR for the Restoration of the Ballona Wetlands. Our association is comprised of constituents whose homes and backyards are directly adjacent to the Ballona Wetlands.

Currently, I am the Chair of the Playa del Rey Development Committee, appointed by Councilmember Bill Rosendahl. Our committee works closely with Councilmember Bill Rosendahl and his staff, in protecting our quality of life and to protect our community from over development. We strive to maintain the quaint village feel that we all appreciate and moved here for.

We thank you for your hard work in organizing all of the entities involved and we look forward to being an integral part of the Ballona Wetlands Restoration Plan.

Warmest Regards,

Julie Inouye & Dr. Michael Rubottom  
Co-founders of the Vista del Mar Neighbors Association (1983 est.)  
310/306.1487  
310/702.9239  
[julieinouye@me.com](mailto:julieinouye@me.com)



VISTA DEL MAR NEIGHBORS

 COPY

October 20, 2009

Dept. of Fish & Game  
4949 Viewridge Avenue  
San Diego, CA 92123  
Information: (858) 467-4201  
FAX: (858) 467-4299  
Regional Manager: Ed Pert

**RE: GATEWAY OF WETLANDS & parking lot**

VDM Neighbors played an important role in the efforts to save the Ballona Wetlands. In fact, many of our neighbors were, and continue to be, members of the Friends of Ballona Wetlands. For this reason, we appreciate all you have done to protect our precious wetlands. We also agree that the parking lot should be upgraded, but we recommend that the primary use should be for the community residents and customers of the local merchants.

Unfortunately, the proposed Gateway use will have a substantial negative effect on our community and our merchants. Traffic is at maximum and parking is at a premium in this area. Increased truck and vehicle traffic will exacerbate this condition. In addition, the outlet on Culver Place to Vista del Mar is one way. Additional traffic will have difficulty turning left on to Vista del Mar, given the Argonaut street intersection and the close proximity to Culver Blvd. There is no traffic light, stop sign or other traffic control to accommodate the additional traffic that will be generated by The Gateway. The impact on our residential community will be significant, including the effect of this additional traffic on public safety, especially children utilizing the nearby public park and baseball field.

Ironically, The Gateway will also have a negative effect on the sensitive ecosystem in the Wetlands. Additional vehicle traffic, as well as large busses, and their emissions will increase the "carbon footprint" in the area. Similarly, the residents (another endangered species) will not be benefited by more car and bus traffic, adding both carbon emissions and reducing available public parking for themselves, visitors and customers of the local businesses.

6508 VISTA DEL MAR PLAYA DEL REY CA 90293  
310.306.1487 julieinouye@wecahre.org

**RE: GATEWAY OF WETLANDS & parking lot – pg. 2**

Under these circumstances, we strongly urge both the Fish and Game and the Coastal Conservancy to reconsider the current use, and to locate The Gateway of the Wetlands on Fiji Way, County of Los Angeles.

We look forward to your reply.

Sincerely,

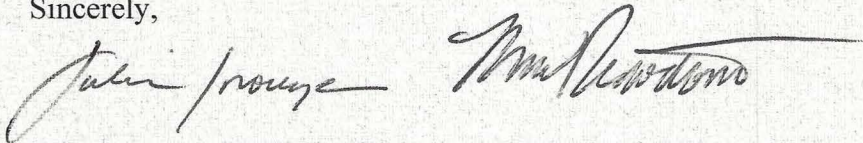
Handwritten signatures of Julie Inouye and Michael Rubottom. Julie Inouye's signature is on the left, and Michael Rubottom's signature is on the right.

Julie Inouye and Michael Rubottom M.D.  
Founders  
Vista del Mar Neighbors Association (est. 1983)

Cc: Assemblyman Ted Lieu  
Senator Jenny Oropeza  
Councilman Bill Rosendahl

**From:** cynthia cannady [<mailto:cccannady@gmail.com>]

**Sent:** Tuesday, August 14, 2012 1:39 PM

**To:** McCormick, Donna

**Subject:** comment

Destroying the Ballona Wetlands would be a terrible mistake. Any politician who supports this kind of destruction will lose my vote and support. We need to do even more to protect our natural world in the LA area. The public trails provide recreation and pleasure to people in central and South LA. How COULD anyone sacrifice nature, citizen enjoyment, our ecosystem and healthy environment for short term objectives? The natural part of Los Angeles is our children's heritage. Don't destroy it.

Cynthia Cannady  
2828 Westshire Drive  
Los Angeles, Ca. 90068

## Jones, Tanya

---

**From:** Lisa A de Vincent [divadevincent@me.com]  
**Sent:** Tuesday, August 14, 2012 10:44 PM  
**To:** McCormick, Donna  
**Subject:** Save the Ballona Wetlands

I support keeping pollution and construction out of the Ballona Wetlands. I lived in Huntington Beach when the Coastal Commission let builders put up a neighborhood in the Bolsa Chica Wetlands, that fiasco is still ongoing. We have so few semi-natural places left on the coast of Southern CA, can they just walk away from this and if they need to build and drege can they do it in an area that isn't a wetlands?

Message to the State - We are killing off the last few natural resources that we have once they're gone that's it. That does have an impact on the life cycle even if it doesn't affect you at your desk let the scientists and those that work on that property guide the outcome.

Lisa de Vincent  
IWOSC Board Member  
Columnist Santa Monica Star  
<http://www.linkedin.com/in/lisadevincent>  
writer/copywriter/proofreader  
[divadevincent@me.com](mailto:divadevincent@me.com)  
424-208-3621  
Sent from iCloud

**Jones, Tanya**

---

**From:** art lee [\[mailto:aprilia1@gmx.com\]](mailto:aprilia1@gmx.com)

**Sent:** Tuesday, August 14, 2012 2:43 PM

**To:** McCormick, Donna

**Subject:** Ballona Wetlands

Donna,

I'm sure you have assistants reading your many emails since I'm sure you are very busy.

All I want to say is that I have gone to the wetlands for many years with my family and we have enjoyed it immensely. I understand that it will be bulldozed in guise of "restoration".

Please do not turn it into a urban polluted drainage dump. A wetland is a biodiverse ecosystem that supports a wide variety of animals and species that has been here well before man took it over. We need to keep wild areas wild or we will lose all sense of nature. Please protect it for our future and our childrens.

Sincerely,

Art Lee

A concerned citizen and nature lover.

**Jones, Tanya**

---

**From:** Colleen Phillips [<mailto:cymax82@hotmail.com>]

**Sent:** Tuesday, August 14, 2012 5:09 PM

**To:** McCormick, Donna

**Subject:** Ballona Restoration EIR

Dear Ms. McCormick,

Even though my property is continuous with Area B, I just happened to find out about the upcoming scoping meeting On Aug 16 and will not be able to attend because of work obligations and such lack of advance notice . I do have to wonder why ,at the very least , the people who live immediately adjacent to the project were not informed of the meeting ?? Since I can not attend, I would like the EIR to address :

1. How will the existing wildlife and immediate neighbors health and safety be addressed during these years ??
2. Will the project affect the stability of the PDR Bluffs overlooking the project ??
3. How will the new containment walls on either side of Culver Blvd redirect the traffic noise ??
4. What are the potential air quality effects of the project and the impact on local residents breathing this for a period of years ??
5. Can't the existing Ballona Wetlands/Creek be restored without the bulldozers - add more inlet channels from the existing Creek and remove invasive vegetation without killing everything currently there ??

Why wasn't the community surrounding the project given more notice about the meeting ??? I think we both know why .....

Colleen Phillips, PharmD  
8100 Billowvista Drive  
Playa Del Rey, Ca

**Jones, Tanya**

---

**From:** Karen Thiers [<mailto:kthiers@sbcglobal.net>]  
**Sent:** Tuesday, August 14, 2012 3:07 PM  
**To:** McCormick, Donna  
**Subject:** I oppose the current proposal for the Ballona Wetlands

There are few things more enjoyable than seeing animals in nature and, with the over-building of the Marina as well as the L.A. area, places where we can observe nature are becoming more scarce every day. This is why it's important to keep the wildlife habitat in the Wetlands as healthy and as undisturbed as possible and to have trails available for people who could not easily make it into the Santa Monica Mountains or other local nature areas.

I regularly commute through that area and over the creek on Culver Boulevard and the amount of junk and oil slick on top of the water is completely disgusting. That has no business contaminating the wetlands where many birds and mammals make their homes and migrating birds stop to rest. Please consider other plans before starting work on the area.

Thank you,

Karen Thiers



**Jones, Tanya**

---

---

**From:** Ashley Wilson [<mailto:wilsonashley@hotmail.com>]

**Sent:** Tuesday, August 14, 2012 12:55 PM

**To:** McCormick, Donna

**Subject:**

Dear Ms. McCormick,

I wanted to put in a comment about how much i object to plans to remove trails from the Ballona Wetland and filter any street drainage into the area. The plan should be to protect the area future not damage it more.

Sincerely,

Ashley Wilson

**Jones, Tanya**

---

**From:** From CGA [<mailto:cgabiz@hotmail.com>]

**Sent:** Thursday, August 16, 2012 10:17 PM

**To:** McCormick, Donna

**Subject:** re: Ballona Wetlands "restoration"

Ballona is a biodiverse ecosystem and has three natural habitat types: salt marsh, freshwater marsh, and wildflower and sage covered uplands. Under the State "restoration" plan, two of those three natural habitats and their wildlife will be mostly eliminated. I support the Ballona Ecosystem Education Project's (BEEP) alternative plan that protects the three existing wildlife habitats and our trails, allows some re-wetting of appropriate portions of the wetlands, and brings in clean water from the ocean—approximating conditions existing 200 years ago.

Sincerely,

Carolyn Anderson  
Los Angeles

cf: <http://ballona-news.blogspot.com/2012/08/first-big-public-hearing-on-ballona.html>

**Jones, Tanya**

---

**From:** Christopher McKinnon [<mailto:chrispm@afewgoodideas.com>]

**Sent:** Thursday, August 16, 2012 3:04 PM

**To:** McCormick, Donna

**Subject:** Comments Ballona Wetlands Restoration Project

Ballona Wetlands Restoration Project

Although I laud the restoration of these important wetlands I fear that any use of large mechanical earth moving equipment will do more damage to the plant and animal environment than good. Please employ 100's of union manual laborers and trainees to do this work by hand. If any power equipment is used it should be powered by natural gas or clean diesel.

Thank you,

Christopher McKinnon

Los Angeles, CA 90066

## Jones, Tanya

---

From: Lucien Plauzoles [<mailto:plauzoles@me.com>]

Sent: Thursday, August 16, 2012 11:09 PM

To: McCormick, Donna

Cc: Ellen Thayer Vahan; Adrian Douglas; Chuck Almdale; Mary Prismon; Lillian Johnson; Liz Galton; Cindy Schotté; Jane Beseda; Chuck Bragg; Jean Garrett

Subject: Ballona restoration "meeting"

Dear Ms. McCormick, I took time off today to attend the "scoping" meeting at the Fiji Way Edison parking lot.

I was very surprised by the lack of solid information available from the agency and consultant teams.

What I noticed was that all personnel present were well trained in conflict avoidance, to the expense of solid information.

Is it because I walked into the parking area at the same time as Marcia Hanscom that I was "dodged" on every question?

I actively participated in the Ballona Watershed task force 7-11 years ago. I was accustomed to rather straight, serious answers.

When I keyed in the linked [www.ballonarestoration.org](http://www.ballonarestoration.org) address from Aug. 13th through 16th, I was not able to get ANY information.

Are we feeding Marcia? (...who was standing in the parking lot when I drove in, gathering an audience?)

Please give me some solid links that tell me what has really happened in the past 5 years at the meetings we either could not or declined to attend. What exactly are the alternatives being considered, ...or are they really not even set as alternatives as one of the SMBRC representatives vaguely said? Our only information about alternatives under consideration has been gleaned from Ballona Renaissance's newsletters.

We are active, funding stakeholders in the Ballona restoration process. We are active in making Ballona relevant to the residents of the entire watershed through our educational activities with Friends of Ballona.

If you refer to many of the existing documents on line and in the written record, we, as a group of approximately 1,000 active stakeholders, have a moderate record of careful examination of scientific and political data on most questions. We would like to either sustain or try to oppose Ballona restoration projects. We truly would like to have more information on the state of the Ballona restoration project before it is cast in concrete by a consultant. However, we have no idea of the "state of affairs" from this evening's meeting. It seemed to be an exercise in decision/question avoidance.

I was, this evening, surprised by the "fill in an opinion card" response to any question I might pose, whether it might, in some time, be controversial or not. The information presented was not even sketchy--it was not a 10th of what was presented on your company's/CA F and G's website!

Granted, avoidance of controversy makes decision-making smoother, however, your consultancy as well as any agency owes us more!

Would it be of interest for a representative of your firm to make a short presentation at one of our monthly evening meetings, starting October? We meet at the Ken Edwards Center in Santa Monica on the first Tuesday of each month, (Oct, Nov, Dec, Feb, Mar Apr May)? Please let me know with a few weeks' notice if there is any interest.

Lucien (Lu) Plauzoles, M.S.  
Co-chair Conservation



## Jones, Tanya

---

**To:** McCormick, Donna  
**Subject:** RE: Fwd: BALLONA WETLANDS Restoration; Public Process Thwarted

From: patricia mc pherson<mailto:patriciamcpherson1@verizon.net>  
Sent: Thursday, August 16, 2012 07:51  
To: Scott Valor<mailto:svalor@santamonibabay.org>  
Cc: jd@johnanthonydavis.com<mailto:jd@johnanthonydavis.com>; Hanscom Marcia<mailto:wetlandact@earthlink.net>; bill.rosendahl@lacity.org<mailto:bill.rosendahl@lacity.org>; sschuchat@scc.ca.gov<mailto:sschuchat@scc.ca.gov>; jeanette@culverevents.com<mailto:jeanette@culverevents.com>; Roy VanDeHoek<mailto:robertvandehoek@yahoo.com>; David Warren<mailto:davidw20003@yahoo.com>; Ferrazzi Paul<mailto:razzip1@ca.rr.com>; Joe Young<mailto:joengeri@ca.rr.com>; john.laird@resources.ca.gov<mailto:john.laird@resources.ca.gov>; bill.lockyer@treasurer.ca.gov<mailto:bill.lockyer@treasurer.ca.gov>; jeanne.H.Imamura@usace.army.mil<mailto:jeanne.H.Imamura@usace.army.mil>  
Subject: Fwd: BALLONA WETLANDS Restoration; Public Process Thwarted

TO: ALL SANTA MONICA BAY RESTORATION COMMISSION- Commissioners & Alternates ;  
ALL BAY WATERSHED COUNCIL

% Scott Valor acting on behalf of SMBRC/BAY WATERSHED COUNCIL

C/O- Scott Valor is requested to send electronic copy of this message to all parties listed above.

The parties listed above, in the past, have not received written comments delivered by the public and stakeholders at EITHER the SMBRC Governing Board Meetings and/or Executive Committee Meetings. The website for SMBRC has not

posted, as requested, any and all public comments from the meetings. Written public comments delivered at the SMBRC Meetings have also had no response from SMBRC to the public. ( One GC query/comment letter had internal SMBRC intercommunication but was only rendered to the public via a Public Record Act request.) The failure by SMBRC to provide any and all public

comments from these meetings to the parties listed above has created a disconnect of information between the public and this

state agency that is contrary to the mission and goals of the this state agency.

RE: SMBRC MEETING AUGUST 16, 2012 - PUBLIC COMMENT Pertaining to the Ballona Wetlands Restoration Process - A Failed Process By SMBRC

FROM: GRASSROOTS COALITION, Patricia McPherson-President

Begin forwarded message:

From: patricia mc pherson <patriciamcpherson1@verizon.net<mailto:patriciamcpherson1@verizon.net>>  
Subject: BALLONA WETLANDS Restoration; Public Process Thwarted  
Date: August 2, 2012 12:37:36 PM PDT  
To: sschuchat@scc.ca.gov<mailto:sschuchat@scc.ca.gov>, dwayman@scc.ca.gov<mailto:dwayman@scc.ca.gov>, npeterson@scc.ca.gov<mailto:npeterson@scc.ca.gov>, carmen@scc.ca.gov<mailto:carmen@scc.ca.gov>  
Cc: john.laird@resources.ca.gov<mailto:john.laird@resources.ca.gov>, john@sco.ca.gov<mailto:john@sco.ca.gov>, ana.matosantos@dof.ca.gov<mailto:ana.matosantos@dof.ca.gov>, billrosendahl@aol.com<mailto:billrosendahl@aol.com>, bill.lockyer@treasurer.ca.gov<mailto:bill.lockyer@treasurer.ca.gov>,

jeanne.h.Imamura@usace.army.mil<mailto:jeanne.h.Imamura@usace.army.mil>,  
hamilton.cloud@mail.gov<mailto:hamilton.cloud@mail.gov>,  
adolfo\_bailon@boxer.senate.gov<mailto:adolfo\_bailon@boxer.senate.gov>,  
michael\_davies@feinstein.senate.gov<mailto:michael\_davies@feinstein.senate.gov>, Kulla Norman  
<norman.kulla@lacity.org<mailto:norman.kulla@lacity.org>>

To: Coastal Conservancy  
Attn. All Governing Board Members and Alternates

From: Grassroots Coalition, Patricia McPherson, President

RE: Complaint and Request re: Support to the J. Davis 3/29/12 REQUEST TO RESCIND APPROVAL FOR STAFF RECOMMENDATION APPROVAL ON 1/19/12 awarding \$6,490,00. for: FILE NO. 04-088- BALLONA WETLANDS RESTORATION ENGINEERING AND TECHNICAL STUDIES and, Request for the Coastal Conservancy to stop its interference in the approved and ongoing 2005 Joint EIS/EIR process regarding restoration of the Ballona Wetlands Ecological Preserve.

Respectfully submitted,  
Patricia McPherson, Grassroots Coalition

---

---

---

---

---

TO: ALL SANTA MONICA BAY RESTORATION COMMISSION- Commissioners & Alternates ;  
ALL BAY WATERSHED COUNCIL  
% Scott Valor acting on behalf of SMBRC/BAY WATERSHED COUNCIL  
C/O- Scott Valor is requested to send electronic copy of this message to all parties listed above.

The parties listed above, in the past, have not received written comments delivered by the public and stakeholders at EITHER the SMBRC Governing Board Meetings and/or Executive Committee Meetings. The website for SMBRC has not

posted, as requested, any and all public comments from the meetings. Written public comments delivered at the SMBRC Meetings have also had no response from SMBRC to the public. ( One GC query/comment letter had internal SMBRC intercommunication but was only rendered to the public via a Public Record Act request.) The failure by SMBRC to provide any and all public

comments from these meetings to the parties listed above has created a disconnect of information between the public and this

state agency that is contrary to the mission and goals of the this state agency.

RE: SMBRC MEETING AUGUST 16, 2012 - PUBLIC COMMENT Pertaining to the Ballona Wetlands Restoration Process - A Failed Process By SMBRC

FROM: GRASSROOTS COALITION, Patricia McPherson-President

Begin forwarded message:

> From: patricia mc pherson <patriciamcpherson1@verizon.net>

> Subject: BALLONA WETLANDS Restoration; Public Process Thwarted

> Date: August 2, 2012 12:37:36 PM PDT

> To: sschuchat@scc.ca.gov, dwayman@scc.ca.gov, npeterson@scc.ca.gov,

> carmen@scc.ca.gov

> Cc: john.laird@resources.ca.gov, john@sco.ca.gov,

> ana.matosantos@dof.ca.gov, billrosendahl@aol.com,

> bill.lockyer@treasurer.ca.gov, jeanne.h.Imamura@usace.army.mil,

> hamilton.cloud@mail.gov, adolfo\_bailon@boxer.senate.gov,

> michael\_davies@feinstein.senate.gov, Kulla Norman

> <norman.kulla@lacity.org>

>

>

> To: Coastal Conservancy

> Attn. All Governing Board Members and Alternates

>

> From: Grassroots Coalition, Patricia McPherson, President

>

> RE: Complaint and Request re: Support to the J. Davis 3/29/12 REQUEST

> TO RESCIND APPROVAL FOR STAFF RECOMMENDATION APPROVAL ON 1/19/12

> awarding \$6,490,00. for: FILE NO. 04-088- BALLONA WETLANDS

> RESTORATION ENGINEERING AND TECHNICAL STUDIES and, Request for the Coastal Conservancy to stop its interference in the approved and ongoing 2005 Joint EIS/EIR process regarding restoration of the Ballona Wetlands Ecological Preserve.

>

> Respectfully submitted,

> Patricia McPherson, Grassroots Coalition

>

>

>

>

>

>

>

>



**FROM: Grassroots Coalition,**  
Patricia McPherson, President  
Patriciamcpherson1@verizon.net

**August 2, 2012**

**TO:**  
**California Coastal Conservancy**  
Attn. Executive Director, San Schuchat &  
All Governing Board Member and Alternates

CC  
John Chiang- CA. State Controller  
Matosantos- CA. Dept. of Finance Director  
Bill Lockyer- CA. State Treasurer  
John Laird- Dept. of Natural Resources  
U.S. Army Corps of Engineers Attn. Commander Mark Toy  
U.S. Senator Barbara Boxer  
U.S. Congress Person Maxine Waters  
L.A.Councilman Bill Rosendahl

**RE: Complaint-** Supporting the 3/29/12 REQUEST TO RESCIND APPROVAL FOR STAFF RECOMMENDATION APPROVAL ON 1/19/12 awarding \$6,490,00. for: FILE NO. 04-088-

**BALLONA WETLANDS RESTORATION ENGINEERING AND TECHNICAL STUDIES**

The following paper from Grassroots Coalition (GC) represents GC's opinion of its findings and data support garnered via the Public Record Act and the Freedom of Information Act.

**This document also requests the Coastal Conservancy to stop its illegitimate interference in the approved and ongoing 2005 Joint EIS/EIR process between the Sponsor-- Santa Monica Bay Restoration Commission (SMBRC)/ LA County Flood Control and, the U.S. Army Corps of Engineers.**

**The Coastal Conservancy, using its control over public bond money, has shut out the public process and taken its influence as a financially powerful board member of the SMBRC and partner of the California Department of Fish & Game (DFG), the lead agency of the publically owned Ballona Wetlands—to fund a process that is contradictory to the 2005 federal process that was requested by Congress.**

**The Coastal Conservancy is propelling a bait and switch - a NEW Joint EIR/EIS process and a NEW Notice of Intent (NOI) that undermines and attempts to extinguish the current 2005 Joint EIS/EIR APPROVED PROCESS with its attendant safeguards of multiple habitat restoration alternatives.**

**The Coastal Conservancy is instead, illegitimately propelling a singular outcome that stops restoration of Ballona and protection of its endangered species to instead convert the habitat into a non-historical dredged out estuarine habitat that promotes LA Port expansion and other financial deals.**

**Background:**

In 2004, Ballona Wetlands acreage was purchased via PUBLIC funding for approximately \$140 million. **The land is owned by the public** and is currently administered by the California Dept. of Fish and Game (freshwater marsh portion by the State Lands Commission) .

**Important, new information** contained herein reflects a Coastal Conservancy (CC) Public Record Act (PRA) response consisting of numerous heretofore undisclosed CC documents contained on a CD. The CD was provided after the 1/19/12 CC Governing Board Hearing in Los Angeles, CA. and, after the CC Governing Board's Hearing in Ventura, CA. on 3/29/12.

**I.**

**The Coastal Conservancy PRA CD provides evidence to show that misleading and/or incorrect information was presented in the Staff Recommendation of 1/19/12 (File No. 04-088)**

The newly disclosed Coastal Conservancy documents (CD) reveal:

- A. potential misuse of public bond money (Prop. 12, PRC 5096.352 (f) and or (b)(1));
- B. lack of disclosure, lack of public process and transparency of process regarding the Coastal Conservancy's involvement and; associations with other agencies --federal- US Army Corps of Engineers (USACE) and; state agencies and; a private nonprofit- the Santa Monica Bay Restoration Foundation (Foundation) that pertain to Ballona Wetlands in Los Angeles, CA.
- C. Prop. 12 ( Number 172 of Dept. of Natural Resources Listing of Prop. 12 bond grants; 3760-30203-0005(2)(B)07) Coastal Conservancy bond grant to The Southern California Coastal Water Research Project (SCWRP) -Ballona Wetlands Restoration. The Coastal Conservancy, contrary to the bond grant language and intention of allowing for a "scientific advisory committee" (SAC) to review and advise regarding '**enhancement**' plans for the restoration goals of Ballona Wetlands; the Coastal Conservancy instead propelled and directed SCCWRP members and other contractors to perform a singular outcome of '**creation**' of a **full tidal/ estuarine, non-historical , treatment wetland as an end of pipe, experimental solution to the toxic contamination of Ballona Creek.**

The CC Staff Recommendation is a non-historically oriented goal and thus fails to adhere to bond language for “enhancement” of Ballona Wetlands and also fails to adhere to “restoration” as defined by Southern California Wetlands Recovery Project (SCWRP). (See p.3 SCWRP restoration definition) And, contrary to publically stated and written goals of transparency and interchange, the CC and SMBRC precluded the public and Working Group from participating and interfacing with SAC. Thus, the CC and SMBRC, utilizing all public bond dollars have effectively shut the public out of the Ballona Wetland Restoration design process.

Contrary to comments made below in the Staff Recommendation 1/19/12 (File No. 04-088), the conceptual restoration plan was **not** developed in a public process and the public and other parties were **precluded** from participation in all facets of the development of the restoration alternatives

*“Cooperation: The conceptual restoration plan was developed in a public process with input from a Science Advisory Committee, an Agency Advisor Committee, and the Ballona Working Group made up of representatives of local nonprofit organizations, agency staff and members of the public. Individual public members also participated in all facets of the development of the restoration alternatives.”*  
(p. 9 of 9 1/19/12 Staff Recommendation; Emphasis added.)

The CD documents reveal that the conceptual restoration plan was developed by the Coastal Conservancy and by the executive director and staff of Santa Monica Bay Restoration Commission- a California state agency.

**Note- the SMBRCCommission’s executive director and most staff are not state personnel . Since 2005, the executive director and staff of the SMBRFoundation (a private 501c3) simultaneously act as SMBRC staff and executive director. IRS records reveal payment to the Foundation’s executive director and staff from the Foundation. We have found no contractual authority for such private persons to serve as state officers of a state agency or as staff of a state agency. We are currently requesting an assessment and investigation into these matters of great public concern.**

The CD documents reveal that the Coastal Conservancy Staff Recommendation was created:

1. in a void of public/ Working Group input acknowledgement and use.
2. in a vacuum of interchange between the Scientific Advisory Committee and the public/ Working Group and the USACE contractual agreements.
3. while failing to disclose scientific findings to all parties and;
4. while failing to provide process as written by the Coastal Conservancy.
5. without adherence to the 2005, contractual agreement between the United States Army Corps of Engineers (USACE) and the Sponsor (aka the Authority- SMBRC & LA County Flood Control) wherein a Joint EIR/ EIS of Corps certified programs of environmental review would take place and;

6. without CC Governing Board authorization and without public disclosure-- the CC Project Manager created an enterprise consisting of a 'new' Joint EIR/EIS process ostensibly intended to circumvent the 2005 approved process. (JD submission to CC 3/29/12)

7.

### Lack of Disclosure Has Led To An Inability To Make Informed Decisions

#### I.

#### **A. Proposition 12 Funds-The Public's Intent - To Acquire, Protect and Restore Is Not Fulfilled.**

The Prop. 12, Public Resource Code (PRC) Section 5096.352 language states, “ (f) Twenty-five million dollars (\$25,000,000) of the funds shall be allocated to **acquire, protect, and restore** wetlands projects that are a minimum of 400 acres in size in any county with a population greater than 5,000,000. (Emphasis added. The Ballona Wetlands is distinguished as fulfilling this specific criteria.)

**Restoration**—specifically refers to actions taken to obtain a former state of a natural condition. (Southern California Wetlands Recovery Project (SCWRP)- Science Advisory Panel (SAP)- Glossary of Terms)

Estuarine wetlands- are subtidal and intertidal habitats that are semi-enclosed by land, have access to the open ocean, and in which ocean water is at least occasionally diluted by freshwater runoff from the land (Cowardin et. Al. 1979)SCWRP, SAP Glossary)

. Ballona was not historically continually open and connected to the ocean and large, inundating flows of fresh water occurred infrequently only during major flood events (CD- SAC docs; USGS docs provided to CC by J. Davis; CC's T-sheets).

**“The project we are recommending is enormous in scale.”** CC- MarySmall (JD PRA Response attachment in 3/28/12 CC Hearing-Request )

**Contrary to “protecting and restoring” the Ballona habitat**, the approval of the Engineering and Technical Studies & SMBRC bond awards will specifically promote a singular outcome— massive destruction of currently functioning habitat that will not ‘obtain a former state of a natural condition’ but, will instead endeavor upon a non-historically oriented, experimental estuarine treatment wetland project expected to encounter yearly flooding and scouring events. The project is not expected to be self-sustaining but instead expected to promote a perpetual money pit of contracts for monitoring and unknown but expected repairs and fixes- - future landscape changes further transfiguring the flora and fauna. (CD/SAC)

A failure to adhere to grant proposal requirements, as dictated by the State of Ca. Finance Dept. in recent audits, continues

.  
NOTE: While the Coastal Conservancy promotes the idea that it provides bond grants to the SMBRC, the Coastal Conservancy has actually never provided any bond money to the SMBRC as per the 2002,

SB 1381 Keuhl bill that established a Treasury Account for the SMBRC. Instead, the Coastal Conservancy provides public bond money grants to the private nonprofit—the SMBR Foundation—typically without a grant proposal having been provided—as is the case in the 1/19/12 grant approval.

Recent audits of the CC by the California Dept. of Finance require that the CC adhere to grant proposal requirements established by the Dept of Finance. However, the CC's failure to adhere continues as is the case in the 1/19/12 grant approval.

The currently clean land (LARWQCB) and functioning habitats—include endangered and rare Southern California native plants and wildlife, which will be destroyed in order to create the end of pipe, treatment wetland for toxic Ballona Creek waters and sediments. ( CD-SAC) The full tidal, estuarine goal also appears to discharge political favors for LA Port expansion(s) approvals that need wetland mitigation credit(s) and/or extensive fill material from Ballona.  
(See e-mails regarding LA Port - letters of support for the Staff Recommendation)

**Contrary to the 8/13/04 CC MEMO (p.4),** the CD –SAC documents reveal wildlife and habitat destruction and dangers, endless and exorbitant financial costs, inability to show sustainability and potential legal quagmires that were not revealed to the public/ Working Group and other parties-- some of whom were asked to sign onto Coastal Conservancy pre-scripted letters of support for the 1/19/12 Staff Recommendation.\*

\*Contrary to the promised 'transparency' of process; CC and SMBRC staff improperly lobbied for letters of support for the 1/19/12 Staff Recommendation prior to a public notification of an agenda and release of the Staff Report thusly, discriminating against all others by failing to provide the same comment opportunity prior to the issuance of the Staff Report.

The public has a right to know the full extent of issues regarding changes to Ballona. Whatever decisions are rendered, they should not be based upon piecemealed, truncated and biased information as has currently been provided.

### **PROPOSITION 12 Identification of Funds; Status of Funds**

The Staff Recommendation(SR) is unclear which Proposition 12 funds are being requested. Two possible funding sections of Prop. 12 are:

- Proposition 12 bond money discussed in the SR as specifically for Ballona Wetlands is listed under Public Resource Code (PRC) Section 5096.352 (f)). The accounting for these funds was not provided in the Staff Recommendation and remains unknown.

-Other Prop 12 funds include: PRC Section 5096.352(b)(1)—to the Santa Monica Bay Restoration Project/Bay Watershed Council; that account status remains unclear also.

(In 2002, Senate Bill 1381 (Keuhl) transformed the SMBR“Project” into the SMBRCommission. Prop. 12, PRC language utilizes the Bay Watershed Council. The ByLaws of the the Bay Watershed Council (BWC) remained intact which now give rise to

questions regarding the actual existence of the BWC after SB 1381 which may influence the use of the Prop 12 bond funds.)

## I.

### **B. 5-6. The Coastal Conservancy Project Manager and SMBRC Executive Director/ Staff, Have Not Been Forthright With the Public Regarding Disclosure of Process Changes Pertaining to Federal (USACE) Contractual Agreements**

#### **U.S. ARMY CORPS OF ENGINEERS**

1994, Sept.28 Adopted- "Resolved by the Committee on Public Works and Transportation of the United States House of Representatives, That the Secretary of the Army is requested to review the report of the Chief of Engineers on Playa del Rey Inlet and Basin, Venice, California published as House Document 389, Eighty-third Congress, Second Session, and other pertinent reports, to determine whether modifications of the recommendations contained therein are advisable at the present time, in the interest of navigation, hurricane and storm damage reduction, environmental restoration and other purposes at Marina del Rey Harbor, Los Angeles, California, with consideration given to the disposal of contaminated sediments from the entrance channel required under the existing operation and maintenance program at Marina del Rey Harbor."

In 2005, USACE Noticed and embarked upon an areawide ecological review- an EIS- of the historic Ballona Wetlands area that included the U.S. 83th Congress -- House Document 389 under Public Law 780. Map-Enclosure No. 1 (General Plan of Improvement) reveals the entire Ballona region as part of this action including but not limited to Ballona Lagoon, Del Rey Lagoon and the Sanctuary area , Ballona Creek, Centinela Creek etc. (See language of the USACE Lower Ballona Creek Restoration Reconnaissance Study and; Feasibility Study). This EIS was predicated upon having a local Sponsor as part of the review process and to aid in the outreach to the PUBLIC and the creation of the Joint EIR/EIS process.

SMBRC/LA Flood Control (the Authority) aka the Sponsor-- contractually agreed to the Joint EIR/EIS in 2005.

The contract included having the Sponsor (Authority) provide at least 6 public meetings dedicated to providing time for USACE representatives to discuss the USACE status of the Joint EIR/ EIS process. The follow through for such meetings has not occurred.

(In various earlier approved bond requests for Ballona projects; Project Manager Mary Small eliminates reference to the 2005 contractual agreement for a Joint EIR/EIS which jointly provides for the Ballona Restoration Alternatives ( 2005 contract between- USACE and SMBRC/LA Flood Control aka Authority) Instead Ms. Small's staff recommendations inform the CC Governing Board that as of 2005 only the Ca. Dept. of Fish & Game, State Lands Commission and SMBRC are part of the oversight of Ballona and alludes that the Conservancy has the restoration alternatives planning duties:

(Ballona Wetland Improved Public Access; File No. 04-088; 7/21/10)

*"In 2005, the Conservancy initiated conceptual planning and feasibility analysis of restoration alternatives*

*for the property. This project is being implemented in partnership with the DFG and the State Lands Commission, the two state agency owners of the property and the Santa Monica Bay Restoration Commission. The feasibility analysis was completed in 2008, after a delay due to the bond freeze, and the project partners are now initiating environmental review and detailed engineering of a long-term, phased restoration project. When the restoration planning began, the Conservancy funded the development of an Interim Site Stewardship Plan to address the pressing concerns related to site management. As discussed above, in 2008 the Conservancy provided a grant to MRCA to fund construction of some site improvements and to fund planning, design and preparation of permit applications for additional access improvements. Based on the completed planning work, the MRCA and the project partners determined that it will be more cost effective and logical to pursue implementation of most access improvements as part of the environmental review and permitting for the long-term phased restoration project.*

**PROJECT FINANCING:**

*Coastal Conservancy \$280,000*

*MRCA 120,000*

*SMBRC, US EPA funds 20,000*

*Total Project Cost \$420,000”*

This is an omission of pertinent and critical fact given in order to garner public bond money. ( See J. Davis 3/28/12 Request to CC Gov. Brd.; USACE/CC minutes of meeting(s) and page 6)

See also File No. 04-088 on page 17.

Additionally, the bond money was approved but accountability for its use has not been forthcoming. And,

No fund award was given to SMBRC from the USEPA as cited above. The Treasury Account set up for the SMBRC under SB1381 was not utilized. Instead, ostensibly the USEPA funds went to the private nonprofit, the Foundation. The Foundation, as a private non-profit 501c3, provides no accountability to the public.

The Coastal Conservancy, had also made promises to the public regarding transparency and public inclusion in the entire process of exploring **all reasonable alternatives for enhancement of Ballona.**

For example in an early Coastal Conservancy MEMO dated 8/13/04 to California Department of Fish & Game (DFG) and the State Lands Commission (SLC), the **GOALS/PRINCIPALS read in part-**

***“The restoration plan will be based on the best science, incorporate technical scientific expertise and will be developed through a transparent planning process that allows stakeholders to provide input and comment on all restoration planning products. The restoration planning process will develop and analyze a range of alternatives to implement the following project goals:***

***-Restore and enhance a mix of wetland habitats to benefit endangered and threatened species as well as other migratory and resident species;***

***-Provide for wildlife-oriented public access and recreation opportunities; and –***

***Implement a technically feasible, cost effective, ecologically beneficial and sustainable restoration.” (Emphasis added.)***

And,

*“..restoration will be conducted within the landscape and watershed context, with attention paid **to adjacent and ecologically related resources.**” Pg. 1*

According to CD documents, the Coastal Conservancy’s Ballona project manager participated in USACE meetings in the 2004 timeframe citing inclusion of the areawide ecosystem eg. Ballona Lagoon, Del Rey Lagoon, the Sanctuary area, Marina del Rey and others that paralleled the activities of ecosystem review as described by the USACE ( Reconnaissance Study; Lower Ballona Creek Restoration Feasibility Study; 3/28/12 J.Davis submission to CC)

However, in contradiction to the 8/13/04 Memo cited above, the context of the larger historic boundaries of Ballona Wetlands were later arbitrarily dropped, without public notification or discussion. The CC Project Manager discusses no longer including the adjacent and ecologically related resources as part of the Joint EIR/EIS restoration evaluation performed with the USACE:

6/2/10 CC, SMBRC, USACE Ballona Coordination Meeting Minutes:

*“II. b. Mary Small: Have all the PMP sections looked at the same project area? Parts still refer to Ballona Lagoon, Grand Canal, Venice Canals and Oxford Basin, which are no longer in the study area. ( 3/28/12 CC hearing; J. Davis Attachment)*

**And, the Project Manager discusses instead a ‘new’ process for which there is no ostensible authority and to which the public has not been made aware:**

*“Mary Small: If the Corps falls too behind, we will work with Corps Regulatory for a permit for their activities (NEPA/CEQA, design, permitting, and Phase 1 construction)” and;*

*“Mary Small: It was always our understanding that the Corps would use our restoration alternatives. It makes us nervous that this was never in writing.”(6/28/10 Ballona Ecosystem Restoration Planning Management Meeting)*

It was never the public’s understanding that the Corps would be held to Coastal Conservancy and Foundation staff’s restoration alternatives. Legal legitimacy for such behavior is also questionable. And,

*“Suggested response*

- 1) The EIS/EIR process begun in 2005 was for the Army Corps’ Lower Ballona Ecosystem Restoration Feasibility Study, that project and the associated environmental review has not been completed and is not moving forward at this time. The EIR/S process for the proposed enhancement project will be separate.” 2/7/12*

CC/Mary Small to Ca.Dept. Fish & Game- Rick Mayfield per response to Davis Ballona CEQA process query. (JDavis attachment 3/28/12 Request to CC Board)



Thus, the CC switch in process is 'suggested' to be disclosed to a member of the public after seeking and garnering approval for the 1/19/12 Staff Recommendation. ( 3/28/12 CC Hearing, Davis PRA attachment to Request)

This new and unauthorized process discussion continues in the same email, 2/7/12, from Shelley Luce to Mary Small and Rick Mayfield (CDFG):

...." ***The EIR/EIS that we want to start*** is for a separate project, i.e. the BWER restoration/ enhancement project. ".. (emphasis added.)

The EIR/EIS that they want to start IS NOT on a separate project but instead on the same project but having eliminated the '94/ 2005 Joint EIR/EIS process; scope of review; environmental safeguards and full range of alternatives inherent in '94/ 2005 approved process.

In other words, the CC attempts to have the public and the USACE but out of their way so that the CC can control the project --using the public's dollar--alongside its political allies.

And, while Mary Small provides the appearance that the Request For Proposals is new online--" *the request for services ....went out today*" ....

2/8/12 CC email (JDavis PRA response attachment in 3/28/12 Request to CC Board)

The Coastal Conservancy, had already put out an online RFP in 2010 for the work requested for approval in the 1/19/12 Staff Recommendation. Thus, it appears that as of 2010, the outcome was already a done deal behind the public scene.

Changes, such as this were not communicated to the Public/ Working Group and the ongoing status of the relationship with the USACE as per the Joint EIR/EIS was not communicated either. In fact, the USACE- Sect. of the Army was not made aware of the attempt to extinguish the earlier, approved process. Any extinguishing of the approved EIR/EIS process (including House Document 389) would have to abide by the USACE process of removal. The process provides accountability for reasoning as to the ending of the project as well as detailed accounting for money spent and what had occurred throughout the process. This activity has not occurred and the USACE has provided a letter stipulating that the approved process is maintained and that investigation into the matter has started. ( USACE-J.Davis communication).

It is also unclear whether USACE/SPONSOR information was communicated to the Science Advisory Committee or other parties. Specific USACE work projects, including response to House Document 389 and work quality/certification needs are not communicated in any of the CD-SAC meeting notes which appears to show that the SAC team (contracted and paid for with public funds) were fulfilling ONLY the arbitrary GOALS as set forth by the CC Project Manager and SMBRC staff. Issues

such as the protection of groundwater (classified as potential drinking water), an issue of House Doc. 389 and current Los Angeles- Best Management Practices (BMPs) are absent in the meeting minutes.

Thus, the CC and SMBRC staff, provided for an atmosphere of further disconnect, lack of transparency and compartmentalization of information sharing.

And,

the public/Working Group was not made aware that the CC considered itself a part of the USACE/SPONSOR contract (which it is not) —so much a part, that Mary Small apparently believed that the CC would provide the alternative(s) for the USACE in the Joint EIR/EIS:

6/28/10 Ecosystem Restoration Planning Management Meeting:

II. C. 2." *Mary Small: It was always our understanding that the Corps would use our restoration alternatives. It makes us nervous that this was never in writing."*..

This type of very questionable influence was not conveyed publically. According to the USACE, Joint EIR/EIS language, the USACE study would provide for all reasonable alternatives and the process would embrace public disclosure and participation.

**The Coastal Conservancy and SMBRC staff have not been forthright with the public regarding status of the Joint EIR/EIS.**

#### I.

**B. 1- 3. The CD reveals SAC meetings, reports and concerns not shared with the public/the Working Group and other parties. Conversely, the public/ Working Group comments and concerns are not cross- shared.**

Contrary to the 1/19/12 Staff Recommendation, the public, Working Group and others have not been engaged by the Coastal Conservancy as promised and have not been provided with full information from the Science Advisory Committee (SAC) group in order to make informed decisions and provide input throughout the process to date.

Prop. 12 bond money was also provided from the Natural Resources Dept. to the Coastal Conservancy specifically to provide a GRANT to the Southern California Coastal Waters Research Project (SCCWRP)(#172) for creation of a SAC team. Thus, the SAC team was paid with public dollars to perform as an independent scientific advisory panel to provide input and advice regarding historical restoration options. Contrary to the GRANT purposes, the Coastal Conservancy's Ballona Project Manager and SMBRC staff instead told the SAC team what the intended outcome was and that all input was to secure that goal—namely full tidal estuarine and levy removal.

Thus, the Prop. 12 bond money was not utilized as intended.

The Coastal Conservancy and SMBRC staff kept the public and the Working Group out of the SAC loop of information and knowledge thereby thwarting and distancing

any meaningful interchanges and participation as falsely stated in the Staff Recommendation below.

**Staff Recommendation excerpt:**

*“Cooperation: The conceptual restoration plan was developed in a public process with input from a Science Advisory Committee, an Agency Advisor Committee, and the Ballona Working Group made up of representatives of local nonprofit organizations, agency staff and members of the public. Individual public members also participated in all facets of the development of the restoration alternatives.”*

(p. 9 of 9 Staff Recommendation 1/19/12)

And, contrary to assurances that the public would be notified and included on all SAC meetings, the public was not notified or included.

*“MARY S. all SAC meeting are public, all interested parties will be notified and invited, meetings will be structured with SAC addressing issues first and public comment period at the end.”* (CD- 7/20/05 LMU Ballona SAC MTG.)

A 2004 MEMO discusses –

“Ballona Restoration Planning Working Group: Stakeholder Committee and Public Involvement

*“A Ballona Restoration Planning Working Group (brpwg) made up of interested organizations, agencies, and individuals, will meet periodically to obtain project status updates, to provide input, and to support the restoration planning process. These meetings will be open to the public. Subcommittees may be established to address specific issues that may arise during planning.”*pg.2

The language above provided for the public involvement at the start of the process that began with ‘interim stewardship’ meetings, (eg. trash cleanup and education tours) which did occur. As time passed, meetings stopped, informational sharing from agencies and the science team became nonexistent and; the public’s comments were not included in the planning process that continued behind closed doors.

**-Website topic- SAC meeting minutes- was not accessible to the public. Instead, when clicked – the website told the viewer entry was not allowed. -SAC meetings, though described as open to the public, were not. The CD documents reveal that the SAC meetings were, in the main, telephonic and not inclusive of the public. Reports and Memos were not shared with the public but utilized internally.**

A continued failure to acknowledge the public and Working Group is also documented via the 2012 Science Advisory Meeting that was held days after the Staff Recommendation Approval. The SAC meeting was also a first in years for actually occurring and, that public notice was provided.

The Public/ the Working Group:

- provided strong objections to the proposed Plan, providing written testimony as well as oral testimony.
- listed issues that needed to be addressed properly; asked for responses that thus far have gone unanswered and,
- again requested the area be considered in its totality of ecosystem variety and benefits utilizing the historic system of Ballona.
- reminded the SAC that the area now has more saltwater --deep and mid habitat than historically existed at Ballona due to the Marina del Rey; Ballona Lagoon Marine Preserve; Del Rey Lagoon; Ballona Creek itself and; as well as freshwater due to the newly created catch-basin- aka, the freshwater marsh. (historically= the last couple hundred years)
- SAC numerical analysis of habitat types was in error. Ratios of entire Ballona Wetlands historic habitat applied to be fulfilled in Areas A, B, C alone is a faulty analysis. The SAC- ratio numbers that pertained to former water habitat and land elevations were either incorrect and/or not documented by SAC.
- cited and documented that SAC dredge spoils deposition locations and volumes were incorrect. (USGS Documents and maps provided by John Davis to the Coastal Conservancy)

The CC and SMBRC continue to fail to respond.

**Note: The CC continues to fail to respond to queries and comments provided by the public and its so-called "Working Group" members from 1/19/12 and 3/29/12.**

#### **FAILURE TO INCLUDE THE WORKING GROUP COMMENTS AND REQUESTS**

Despite providing comments, documentation and evidence regarding the topics listed above and others; there is no documentation provided from the Coastal Conservancy on the CD that any of the public/ Working Group communications were included for any meaningful response or use.

The CD documents reveal no inclusion of the public in any decision making for the alternatives.

Public comments provided to SMBRC and the Coastal Conservancy regarding Ballona specific studies such as the Phil Williams & Assoc. report, that did not address or incorrectly addressed issues, such as the migrating oilfield gas and reservoir gas leakage from SOCALGAS had no meaningful response. There is no showing that the CC or SMBRC staff ever shared these concerns with the SAC team, much less did any meaningful, good faith follow up with the public to understand how the gases may impact restoration. The same holds true for issues regarding protection and utilization of the Ballona aquifer groundwater hydrology. Repeated requests from stakeholders to be given ½ hour presentation time to provide information regarding hydrology and groundwater diversion issues, before the SMBRC have been met with silence ( The CC is part of the SMBRC) .

I.B.

**CONTROL OF MESSAGE AND OUTCOME**

**The CC and SMBRC Staff :**

**Allow For No Public/ Working Group Participation In The Planning Process;  
Fail to Disclose Science Advisory Committee (SAC) Conference Calls,  
Memorandums and Reports For Planning of Alternatives;  
Feasibility, Cost, Sustainability, Ecosystem Pros and Cons Are Not Disclosed;  
And  
The CC & SMBRC Staff Arbitrarily Define Project Goal=Estaurine**

**Staff Recommendation excerpt:**

*“Cooperation: The conceptual restoration plan was developed in a public process with input from a Science Advisory Committee, an Agency Advisor Committee, and the Ballona Working Group made up of representatives of local nonprofit organizations, agency staff and members of the public. Individual public members also participated in all facets of the development of the restoration alternatives.”*

(p. 9 of 9 Staff Recommendation 1/19/12)

**The 1/19/12 Staff Recommendation excerpt is false.** The public/ Working Group was neither privy to the SAC meetings and information created nor included in the planning process to participate in all facets of the development of the restoration alternatives.

The following excerpts from the CD document an internal discussion revealing the CC and SMBRC staff created and controlled the alternative selection:

*“Wayne (Wayne Ferren) suggested that biological sustainability be defined as no loss of habitat types & functions, major guilds, and sensitive species over the project site as a whole.”* July 7, 2008 SAC Conference Call.

And;

*“Joy (Joy Zedler) asked how biodiversity is being defined? **Sean indicated that biodiversity = highest richness of estuarine dependent species.** If this is how we are defining biodiversity, it should be stated clearly in the document. (emphasis added; Sean Berquist was SMBRC staff and Foundation staff during this timeframe )* and,

*“Wayne suggested that we clarify that biodiversity is the sustainable richness of representative interdependent native estuarine habitats along with their associated and expected species biodiversity.”* (CD-June 23, 2008 SAC Conference Call)

The next paragraph, written by the note-taker- cited by CC as being CC or SMBRC staff- states the goal-

**“Estuarine biodiversity is the primary objective of the analysis.”**

(CD- June 23, 2008 SAC Conference Call Memo)

This same Memo also sets forth a GOAL that was not shared with the public/ Working Group.

*“The project goal is to create functional estuarine habitat...”;*

***“1. Maximize area of estuarine habitat.”;***

*Opportunities to create regionally significant habitat including vernal pools and...should be pursued but **not at the expense of restoration of estuarine habitat.”***

The public/Working Group was not allowed to participate in the decision making and was not advised as to the differing opinions rendered by the SAC team.

Since this timeframe and without public notification or disclosure the Coastal Conservancy and staff of the Foundation have worked to eliminate the areawide review of ecosystem function and alternative habitat plans—including a public debate regarding the pros and cons of each system -- to instead focus upon a predetermined singular outcome of removal of Ballona Creek levees and dredging of Ballona to ‘landscape’ and convert the land from its historic natural function to an entirely new, artificial and unnatural function that precludes all habitat function that does not primarily promote the estuarine full tidal premise.

And though asked publically where this ‘Plan- Alternative 5 ‘ came from, no response has been forthcoming from either the CC or Foundation staff.

The CD docs however now shed light as to the creation of this “preferred plan”. The overtones of financial leverage dominate the first half of the letter and serve to advance a predetermined outcome that is seen fulfilled in the Coastal Conservancy Staff Recommendation—the removal of levees to create the treatment wetlands.

July 10, 2007 SMBRC letter from Shelley Luce to Coastal Conservancy’s Ballona Project Manager- Mary Small:

*“Dear Mary,*

*The Santa Monica Bay Restoration Commission, a National Estuary Program of the US EPA, has been pleased to participate in the acquisition and restoration of the Ballona wetlands at all levels over the last several years. We are proud partners in the restoration planning, and currently have one staff member dedicated full time to the planning effort, while I serve on the Ballona Wetlands Science Advisory Committee (SAC). The SMBRC is also an active local partner in the Army Corps of Engineers’ Lower Ballona Ecosystem Restoration Feasibility Study and are participating in clean up and restoration plans for Ballona Lagoon, the Grand Canal, Marine del Rey and the Oxford Basin. We have also awarded several millions of dollars of bond monies under our purview to projects designed to improve water quality and habitat in the Ballona Creek watershed. Ballona wetlands restoration is clearly a very high priority of the SMBRC and the EPA.*

*I have reviewed the restoration design alternatives that are being developed by the consulting team and I am disappointed that they do not fully consider important restoration options, thereby limiting potential habitat, biodiversity and water quality improvements in the wetlands complex. The Ballona SAC requested design alternatives that encompass the “extremes” of restoration planning, i.e. from minimal intervention to maximal structural changes, as well as alternatives in between. The current proposed*

*alternatives do not provide this and need to be modified, or an additional (fourth) alternative is needed.*

*SMBRC feels that the restoration design for Ballona wetlands must represent a true restoration of maximum ecological functions and services for the area. Actual restoration work will not begin for months or years, and will be a long term and costly process. The best approach is to include design alternatives that are not limited by current infrastructure or fiscal concerns, since these factors will certainly change over the duration of the restoration process. Similarly, factors such as poor water quality in Ballona Creek will continue to change as Total Maximum Daily Loads and other regulatory measures are implemented. It does not serve us to design the restoration as though it would be undertaken and completed in the very near future, under existing physical or financial constraints.*

*I would like to request that the design team include at least one design alternative that proposes to*

- remove all or part of the levees on one or both sides of Ballona Creek;*
- daylight the channel connecting the freshwater marsh to the creek in Area B, and Stingray Creek to Marina del Rey in Area A;*
- raise Culver Boulevard to increase flows between the north and south sections of Area B; and*
- increase connectivity between Ballona Creek and Areas A and B.”*

*Our staff Wetlands Restoration Manager Sean Bergquist is available to work closely with the consulting team to ensure the revised or new alternatives include features that stakeholders and the SAC members supported. The revised or new alternatives should be presented as one of the group of alternatives for consideration under CEQA and by stakeholders and the SAC.*

*Given our experience in and commitment to the Ballona wetlands and surrounding interconnected areas, the SMBRC staff, Governing Board and Watershed Council have a great deal to contribute to the restoration process. Please feel free to consult us further during development of the restoration design alternatives and we look forward to continuing our partnership to restore Ballona wetlands.*

*Sincerely,  
Shelley Luce, D.Env.  
Executive Director*

An e-mail 7/17/07 from SMBRC Commission & Foundation executive officer Shelley Luce,

*“RE: design alternative for Ballona wetland restoration” and Phil Williams & Associates’ (PWA) Jeremy Lowe –*

*“We’ve sketched out Alternative 5 as described in Shelley’s letter. Is this what you were envisaging?”*

*Luce: “ Thank you for your response Jeremy. This is a good start for a 5<sup>th</sup> alternative. Sean and Jessica are adding/changing some details and will forward to you. “*

*(presumably-Sean Berquist and Jessica Hall– both Foundation paid staff/ SMBRC staff)*

The CD documents also reveal two sets of drawings and plans for the levy removal and levy replacement—by Jessica Hall, a Foundation paid staffer.

---

Ms. Luce is the Executive Director of the Foundation; no contractual

agreements

have been produced by the SMBRCommission or the State Water Board that provide any authority for her to act in capacity of Executive Director of the State Agency-

Santa Monica Bay Restoration Commission which was created under SB 1381 Keuhl as a non regulatory state agency within the State Water Board. There have been no contractual agreements forthcoming by the State Water Board or federal authorities that provide for any SMBRC or federal EPA- National Estuary Program (NEP)- dedicated funding to be handed over to the SMBR Foundation. There is a treasury account that was formed under SB1381 in 2002.

The treasury account has never been used. The attendant oversight and accountability by the State Treasurer has likewise not been utilized.

Ms. Luce has been utilizing both the e-mail address and physical location of the LARWQCB as her work address. The utilization of the addresses has led to common belief that Ms. Luce is a Water Board employee. It is unknown but possible at this time to believe that the utilization of the addresses created a belief that Ms. Luce is LARWQCB personnel, which has in turn, provided Ms. Luce with access to controlling positions on various committees such as IRWMP (Integrated Resource Water Management Program). It would seem that by creating, via continued use of LARWQCB email address and business address, a very public belief that Ms. Luce is a Water Board employee may constitute impersonating a Water Board employee. The following is an e-mail exchange between Ms. Luce and a person with long associations with the Water Board and has acted as a contractor in Ballona restoration matters.

*'Travis Longcore [travislongcore@laaudubon.org](mailto:travislongcore@laaudubon.org) wrote:*

*Bounced from your waterboards address. Are you no longer a Water Board employee? –*

*Travis*

*On Sep 19, 2011, at 2:29 PM, Shelley Luce wrote:*

***No, not for many years.** Most of our staff are with our SMBR Foundation. I will check my calendar and get back to you on this meeting, thank you for the invitation.*

*Shelley" (emphasis added)*

Ms. Luce does not appear to answer directly about herself with regard to the Foundation, or what she means by "our SMBR Foundation". She also does not explain her past personal use of the LARWQCB addresses while not employed and why she suddenly discontinued the practice.

Ms. Luce's resume cites her experience prior to SMBRCommission / Foundation as having been employed by Heal the Bay- the organization that has become institutionalized as part of the SMBRC. Our research indicates Ms. Luce was working in some capacity at LARWQCB during the years 1999-2001- prior to her finishing degrees from UCLA. It appears that her continued use of the Water Board e-mail address after no longer providing service to the California Water Resources Control Board has led/misled many people. ( A PRA to LARWQCB is pending for identification of duties.)

#### **Coastal Conservancy- PRA Response to J. Davis**

---

**Rare ecosystems of the coastal marsh area are discussed internally by the SAC team with the CC project manager and staff of the Foundation; the information**



**is not broadcasted for public awareness, inclusion of discussion and decision making as promised.**

*“Rich noted that the discussion of grasslands should include mention of the historical native grassland prairie ecosystems that previously existed in the area. The rarity of native grasslands should be discussed,,,” (CD- 6/28/08 SAC Conference Call)*

*“Rarity section...complex of prairie and vernal pool...  
Wet grasslands formed extensive areas were also palustrine wetlands above highest high tide..” (CD- SAC Call 6/23/08)*

*“...there is native biodiversity in the non-tidal saline soils. .... At Ballona, these wetlands at Area A, for example, are the only habitat where Alkali Barley (*Hordeum depressum*) is known to occur in the Ballona Ecosystem. This annual grass was probably the dominant native annual grass in naturally occurring non-tidal saline soils at Ballona.” (CD- 11/23/08, Wayne Ferren communication to Mary Small...)*

And,

*“The region has a shortage of mudflat for shorebirds, high marsh for animals and salt marsh bird’s beak, marsh-upland transition for rare shrubs (eg. , box thorn) that are used by animals,...*

*The region has a shortage of dune habitat and back – dune depressions that support clean-water brackish marsh for aquatic plants and animals.*

*One could also list maritime scrub, which remains in several places “...  
( CD- Joy Zedler (SAC) correspondence)*

Thus , without public /Working Group inclusion and input into the formation of the alternatives and later failure to include the public /Working Group comments and concerns regarding the PWA Alternatives that are presented at one public meeting--the CC and Foundation staff continue to work behind publically closed doors to focus upon the ‘Preferred Alternative’, now known as Alternative 5 presented in the 1/19/12, Staff Recommendation request for funding. Alternative 5 requires massive, non-historic, extraordinary, experimental and knowingly toxic changes to occur on the land masses of Area A and B so that **“biodiversity = highest richness of estuarine dependent species.”**

**Contrary to the 8/13/04 CC Memo which promised transparency and public inclusion in the alternative planning process** which would “restore and enhance” a mix of wetland habitats....and that would implement a technically feasible, cost effective, ecologically beneficial and sustainable restoration.  
Instead, the public was shut out of the planning process; and SAC knowledge regarding the **needs and dangers posed by Alternative 5 are not made public:**

*“This alternative makes the greatest change to the site, would be the hardest to reverse and consequently has the most risk.” (CD- 9/12/08 MEMO from SAC to PMT )*

*“ ..this alternative would **require reliance on upstream flood control and pollutant removal**, and could necessitate periodic removal of accumulated pollutants for some portions of the restored wetlands. Furthermore, it is unknown how the flow and sediment yield from the upper watershed would affect the sustainability of the marsh in terms of scour or sediment deposition.” CD, P. 4of 9, 10/15/08 SAC MEMO, emphasis added.*

There is no evidence of any such large scale BMP (Best Management Practice) planning or proposals for ‘flood control and pollutant removal’ occurring upstream on Ballona Creek.

And,

*“Eric suggested that there be a statement up front indicating that this site will not be self-sustainable, but will need to be actively managed in perpetuity. ” ( CD- 7/7/08 SAC Conference Call)*

Discussion and comments made from key federal agencies were withheld from the public, including but not limited to **NOAA communications regarding concern of toxicity of Ballona Creek upon the remaining wetlands should the levy removal and dredging take place.** (CD- National Oceanic Atmospheric Association email)

Studies that discuss the toxicity of the Ballona Creek waters and sediment to life in the waters and sediment were not released or shared with the public:

*“These sediments were toxic to aquatic organisms, potentially from organic compounds in these sediments. Ballona Creek has been identified as a potential source of tidal flows into Areas A, B, and C in each of the proposed restoration alternatives. Therefore, there is concern to tidal marsh areas, resulting in a negative impact to the habitats and biological resources.” (CD- Weston –Technical Memorandum 11/26/07; Water Quality Data Gap Investigation Ballona Wetlands Restoration Project- Pohl , P.E., Ph.D.)*

And,

*“ The July 2006 report by Weston also concludes that there are concerns related to water and sediment quality adjacent to the tidal channels. Consequently there is a need to develop a strategy to evaluation the potential ecological risk associated with influent water or sediment quality to the restored wetlands.*

*The scientific questions regarding sediment and water quality cannot be answered based on the information currently available, and will ultimately depend on the design of the project.” (CD- Memorandum 3/8/08; Subject:*

APPROACH FOR ADDRESSING SEDIMENT AND WATER QUALITY ISSUES)

And;

*“Eric- Conc(ept) D—is it attempt to move water and sediment into system*

*Wayne- breaching levee bringing trash, water pollution and sediment into entire area is problematic.*

*John Dixon-important to describe these NOT as projects, but a directions.*

*Ambrose- maybe D is too extreme—this won’t happen anyway.*

*Dixon- do feasible maximum tidal, not D—need to scale back*

*Jeremy- may need to do that, take out realignment Ballona—include realign on Hydrologic options”*

*(CD-10/30/06 SAC Conference Call)*

### **Additional -SPECIFICS OF THE STAFF RECOMMENDATION 1/19/12**

The 1/19/12 Staff Recommendation misleads the public and the Governing Board as seen on pg. 3 of 9, paragraph 5-

*“ In order to complete the environmental analysis required under the National Environmental Policy Act and the California Environmental Quality Act **and to apply for permits** to implement the project, **detailed technical work must be completed.**” (Emphasis added.)*

What is not disclosed to the reader, is an entire change of process from the Congressionally approved 2005 Joint EIR/EIS process requirements.

The Staff Recommendation sentence itself is also very misleading. The applications for permits to the USACE for implementation of the Coastal Conservancy “Plan”, namely the destruction of the levees and the dredging of Ballona have been in process prior to this Staff Recommendation. The Plan-regarding garnering the USACE permits-including the 408- was already in process. (CD)

The Conservancy in its partnership with SMBRC fails to let the public know that they have been working to end the congressionally approved federal portion of the study which entails a full ecological review of the area between the Westchester Bluffs, the Santa Monica Bay, the Santa Monica mountains to a few miles inland – which would also provide for a full review of ALL REASONABLE ALTERNATIVES for enhancement of the ecosystem. ( See minutes of USACE/Sponsor meetings provided in the 3/28/12 [Request to Rescind File No.04-088](#); EIS Lower Ballona Creek Restoration Feasibility Study 2005)

Undisclosed is the take-over of process for Ballona 'restoration' guided by the Coastal Conservancy that may disengage the USACE analysis provided for in the established 2005 Joint EIR/EIS.

Instead, it appears that the Coastal Conservancy along with SMBRC staff seek to simply garner permits from the USACE ostensibly for destruction of habitat on Ballona, in particular Area A and B of Ballona. Specifically, the CC and SMBRC staff seek permits (eg 408) for levee and land destruction and removal. It appears that the extensive dredging and massive bulldozing may provide the necessary fill for the LA Port. Questions from the public regarding the CC/SMBRC/ USACE status have gone unanswered. (CD docs and SMBRC April meeting -submission by GC )

**Contrary to discussion in the Staff Recommendation**—Area A is vegetated primarily by native plants and native wildlife and, is host to endangered species including but not limited to the Belding's Savannah Sparrow.

Not provided to the public are documents and communications which provide, in part, narrative of 'moving' Belding Savannah Sparrows to areas not planned for dredging. This information is vital for public discussion especially since, destruction of the Belding's habitat may wreak havoc upon the Belding population that utilizes Ballona year round. ( CD)

- Pg. 3 of 9 discusses hydrology/hydraulics studies that need to be done. What is not discussed with the reader are the multiple public requests for actual onsite hydrology studies that would include Ballona aquifer and groundwater studies that would provide the knowledge for alternatives inclusive of groundwater use onsite. Ballona has multiple aquifers underlying the site. The aquifers are classified as potential drinking water sources and are part of the West Basin aquifers which intermingle to the south and east. (Poland Report)
- None of the concerns raised in House Document 389 (part of the USACE review) regarding problems associated with further saltwater intrusion have been discussed. The elimination of the USACE EIS as part of the Joint EIR/EIS would hasten the Coastal Conservancy's and SMBRC staff GOALS = Estuarine which in turn would potentially threaten contamination of the underground aquifers as per House Document 389 literature. None of the above has been made a part of any review despite repeated requests from the public for such studies.
- The SOCALGAS operations and oilfield gas migration throughout the Ballona area have also not been discussed despite repeated requests from the public.
- Thus pg 9 of 9 is insufficient and incorrect in its comments regarding the Local Coastal Program and the Coastal Act, including but not limited to the

fact that there is no LCP language that states Ballona requires action as the Staff Recommendation implies as per 31252.

- 
- Staff Recommendation- Pg. 8 of 9 Under “Sea level rise vulnerability”
- The Staff fail to alert the reader that the ‘broad areas of mid marsh and high marsh’ depicted--showing a meandering Ballona Creek mid-way between Area A and B-- will be inundated with yearly flood waters of the contaminated Ballona Creek –potentially killing nesting or burrowing life in the low, mid and high marsh areas. Concerns by the SAC team regarding scouring, trash and contamination were not disclosed in the Staff Report and have not been shared with the public.
- The Staff fail to inform the reader that the Preferred Plan creates a non historic cycling of yearly floods, debris and contamination as part of an end of pipe solution, a treatment wetland device .
- The Staff Recommendation does not disclose the SAC discussion of concerns regarding the creation of a treatment wetland.
- The Staff Recommendation does not alert the reader as to what is achieved with the use of the bond funds via “hydraulics” information. Will the hydraulics information be exclusive to new levy construction?
- The Staff Recommendation does not disclose to the reader, the need for upcreek flood control or contamination control as is discussed by SAC.
- 

**31400- The Staff Recommendation cites enhancement of future NEW trails.**

The Coastal Conservancy has already awarded large grants specifically for the Ballona Bike Trail (File No. 07-058-01) which, currently exists and is heavily utilized by the public. Since, much public funding has already been utilized and will be utilized further for the pathway, why should that same importance of pathway be taken away at Ballona?

Removal of the levies would not only take away a heavily utilized public biking and hiking trail but would also take away the pathway’s use as an observatory promenade for viewing the interior of Ballona. The levees provide an important opportunity for viewing without intruding.

The Coastal Conservancy and other agencies have failed to embrace and include the public on this issue as well. Using the public’s hard earned money while keeping the public out of the planning process reveals the Coastal Conservancy has not acted in good faith.

**Grant Award of \$280,000 to Mountains Recreation and Conservation Authority (MRCA) File No. 04-088 from Staff Recommendation 7/21/10.**

1. The Mountains Recreation and Conservation Authority governing board refused to approve the use of bond money for the trailhead(s) and other enhancements at Ballona. The Board agreed with members of the public. Namely, that due to the ongoing **Joint EIR/EIS** process’ requirements being

more stringent than a singular EIR; those added requirements had to be fulfilled prior to any further decision making taking place.

Mr. Edmiston, at the meeting, asked did they want him to return the money?-

**Ostensibly the bond money had already been approved and given to MRCA. Where did the money go? And;**

2. The 1/19/12 Staff Recommendation cites NEW levy demolition and bike trails ,  
*“the proposed project could provide a new segment of the Coastal Trail . .....the project is located at the intersection of the California Coastal Trail and the Ballona Creek Trail, and may offer a significant opportunity for the development of improved connections between these trails.”* P. 7 of 9 .
  - Since the Coastal Conservancy has been intent upon levee removal of Ballona Creek and dredging the land in the near future; why did the Conservancy give bond money to MRCA for trail head construction and enhancements for Area A (in particular)--apparently an area it intends to soon demolish and dredge? These inconsistencies appear to show misuse of public funds; paying for contractors and salaries for projects that lead nowhere.
  - Furthermore, it appears that when the CC Project Manager of Ballona desires to garner public bond money; the wetlands (or bike path) are discussed in a decidedly positive depiction as below:

*“Despite the degradation of site resources, significant wetland habitat remains within the Ballona Wetlands. Plant species within the project site include wetland indicators such as pickleweed, marsh heather, saltgrass, arrowgrass and glasswort, and a variety of upland and exotic species including brome, iceplant, oxalis, and ryegrass. Bird surveys indicate that the site is used seasonally by a variety of migratory shorebirds, as well as by typical shoreline residents (gulls, terns, and ducks) and typical upland birds including small raptors. Bird species of special interest observed in the project area include nesting pairs of Belding’s Savannah sparrow and foraging use by California least terns. The proposed project will be implemented primarily on the portion of the BWER north of the Ballona Creek channel (Exhibit 2). This area of the reserve currently has very limited public access and suffers from illegal uses. The proposed project seeks to improve the resources on the site, increasing public use while discouraging illegal activities through improvements to fencing and signage.”* File No. 04-088

This same project manager provides an entirely different depiction in the negative—when public bond money is requested for demolition purposes on the same piece of property. Note also the language of utilizing funds to safeguard the property directly contradicts the 1/19/12 Staff Recommendation of the 6 plus million wherein the Project Manager cites the need to demolish and dredge the same area as a means of eliminating public use by the homeless instead of—the aforementioned request for money to protect the same area. ( See also Ms. Small e-mails discussing need to show greater degradation in order to secure the desired outcome. (J. Davis 3/28/12 Request to CC ))  
It appears that the Ballona habitat is characterized dependent upon financial requests---not on reality or science based requests.

- Despite repeated requests for public follow up with regard to the bond money and that project, (including a request made for information at the recent Ballona Watershed Task Force Meeting) none has been forthcoming from MRCA staff or CC staff.

*“In 2008, the Conservancy authorized funds to the MRCA for planning, final design and implementation of specific public access improvements identified in the Ballona Wetlands Early BALLONA WETLANDS PUBLIC ACCESS IMPROVEMENTS Action Plan. MRCA has completed much of that work and as a result of that planning effort, the project partners determined that some of the specific access improvements identified in that plan may need to be re-evaluated and others should be reviewed and permitted as part of the larger wetland restoration project. Rather than pursue the Early Action Plan improvements, the project partners decided that it is a higher priority to develop targeted educational and public access programs in the northern 300 acre portion of the site where there is currently almost no public access. The proposed project would also provide funding for MRCA to continue working on planning public access improvements for inclusion in the ultimate restoration project.”*

**This inconsistency for request/approval and follow-up on bond funds continues to remain unexplained.**

And, how does removal of the levees- the lower leg of the “Class 1 bike path” fit with the public’s money expended below?:

*“In 2000, the Conservancy helped fund a regional plan for creation of a “Park to Playa” river parkway from the Baldwin Hills to Marina Del Rey. The plan envisioned creation of a parkway along Ballona Creek to link expanded parks at the Baldwin Hills to the beaches and the Coastal Trail. In 2001, the Conservancy helped fund the Ballona Creek and Trail Focused Special Study which identified potential improvements to the creek and trail. Consistent with that study, the Conservancy has also provided funding for the construction of a pedestrian bridge in Culver City which increased access to the Ballona Creek Trail. That project has been completed. This project will help to implement the vision of the “Park to Playa” and the Focused Study, developing a multi-benefit, gateway park that will increase access to the trail and enhance the experience of trail users. File No. 07-058-01; Project Manager Mary Small*

*Conservancy funds for this project are expected to derive from the Conservancy’s FY2002/03 appropriation from Proposition 40.”*

3. Staff Recommendation pg. 9 of 9 re: Consistency With Local Coastal Policies fails to provide accurate Local Coastal Plan (LCP )background information.

The Coastal Commission certified the first LUP in 1984, the La Ballona MDR Land Use

Plan.

The Land Use Plan was then changed to reflect two distinctly different Land Use Plans, the La Ballona Plan and the new and different MDR LUP.

It is questionable as to if the California Coastal Commission certified another Land Use Plan for the Playa Vista Project.

Consistency with the California Coastal Act must be consistent with Chapter 3 of that Act.

The Project will not restore, but will instead convert the land from one historic natural function to an entirely new function that is unnatural. Lack of saltwater connection is demonstrated in historic maps from the U.S. Geological Survey. ( A USGS map was submitted at the public hearing on Jan 19,2012. The CC remains nonresponsive)

Grassroots Coalition respectfully requests a written response to this Additional Complaint and maintains its request for response to the 3/29/12 REQUEST TO RESCIND APPLICATION FOR STAFF RECOMMENDATION APPROVAL ON 1/19/12, to award \$6,490,000 Ballona Wetlands Restoration Engineering and Technical Studies. (File 04-088)

The PRA response CD cited herein, is on file with the Coastal Conservancy. Copies of the CD are available upon request and/or are being forwarded.

GC also reserves its right to amend this Complaint and Request with additional information.

Attached is the 3/28/12 Request to Rescind from John Davis to Ca.Coastal Conservancy regarding File No. 04-088

Respectfully,  
Patricia McPherson, Grassroots Coalition-President





REPLY TO  
ATTENTION OF

## DEPARTMENT OF THE ARMY

LOS ANGELES DISTRICT, CORPS OF ENGINEERS  
P.O. BOX 532711  
LOS ANGELES, CALIFORNIA 90053-2325



June 19, 2012

Office of  
District Counsel

John Davis  
PO Box 10152  
Marina Del Rey, CA 90295

RE: Ballona Wetlands

Dear Mr. Davis,

This letter concerns your Freedom of Information Act (FOIA) request dated May 3, 2012. Your request, assigned number FA-12-0109, is enclosed. Please use this reference number in any further correspondence regarding this request.

In your letter, you requested documents related to the Ballona Wetlands, specifically:

- 1) Any and all documents terminating the Environmental Impact Statement process undertaken by the Corps.
- 2) Any and all information regarding financial records of the aforesaid process inclusive of all expenditures of money by the Corps and all money received by the Corps for the same purpose from any source whatsoever.
- 3) Any and all information terminating the local sponsor agreement entered into for the aforesaid purpose between the Corps and the local sponsor, the Santa Monica Bay Restoration Authority.

We have conducted our search and no responsive documents exist due to the following reasons:

- 1) The Environmental Impact Statement process has not been formally terminated.
- 2) There have been no expenditures with regard to a formal termination.
- 3) The local sponsor agreement has not been terminated.

The Program Manager does not anticipate that the EIS process will be terminated in the near future.



DEPARTMENT OF THE ARMY  
OFFICE OF THE ASSISTANT SECRETARY  
CIVIL WORKS  
108 ARMY PENTAGON  
WASHINGTON DC 20310-0108

MAY 30 2012

Mr. John Davis  
P.O. Box 10152  
Marina Del Rey, California 90295

Dear Mr. Davis:

I have been asked to respond on behalf of Secretary of the Army John M. McHugh to your May 11, 2012, correspondence concerning the Marina del Rey Harbor project and the Ballona Creek, California Ecosystem Restoration feasibility study (Ballona Creek study). The Marina del Rey Harbor entrance channel is a Federal navigation project; however the side channels, docks and inner harbor facilities are not a Federal responsibility and are maintained by the Los Angeles County Department of Beaches and Harbors.

The Ballona Creek study is under development by the Los Angeles District of the Army Corps of Engineers (Corps). You asked about the status of the study, the non-federal cost sharing, and the environmental impact statement. The Ballona Creek study is an ongoing feasibility study examining restoration options for coastal wetlands and lagoons. The study and the environmental impact statement have not been finalized, and very limited federal funding is available to continue them. The non-federal sponsor, the Santa Monica Bay Restoration Commission (SMBRC), has provided its share of the study costs through in-kind services, subject to a Corps evaluation and final approval of crediting. Discussions with the SMBRC on the future of the study have been initiated.

If you would like additional details on the Marina del Rey project or the Ballona Creek study, you may wish to contact Mr. Steve Dwyer, Chief, Navigation Branch, Los Angeles District at (213) 452-3385.

Very truly yours,

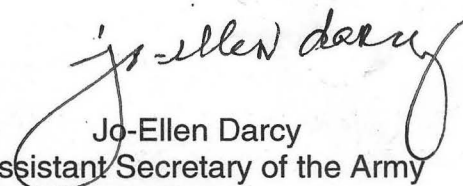
  
Jo-Ellen Darcy  
Assistant Secretary of the Army  
(Civil Works)

California Coastal Conservancy

March 28, 2012

Att: All Governing Board Members and Alternates

Re: PUBLIC COMMENT 3/29/12:

Request to Hold Emergency Meeting to Rescind Approval Action on File No. 04-088

Douglas Bosco  
Marisa Moret  
Ann Nothoff  
John Laird  
Ana J. Matosantos  
Mary Shallenberger  
Susan Hancsh  
Karen Finn  
Bryan Cash  
Noreen Evens  
Joe Simitan  
Anthony Cannella  
Bill Mornning  
Luis Alejo  
Das Williams

CC

John Chiang State Controller  
California Department of Finance Director Ana Matosantos  
U.S. Army Corp of Engineers Att: Commander Mark Toy  
U.S. Senator Barbara Boxer  
U.S. Congress Person Maxine Waters

Honorable Chair Bosco, Distinguished Commissioners,

Attachments will be submitted to the Governing Board on March 29, 2012.

I hereby request this public body instruct its Staff to schedule an emergency meeting in accordance with the Bagley Keene Act section 11125.5(b) to rescind its approval of File No. 04-088 on January 19, 2012 for the following reasons;

**1. NON-COMPLIANCE DEPARTMENT OF FINANCE ATTACHMENT 1  
Final Report—Audit of California State Coastal Conservancy's Propositions 12, 13, 40, 50 Bond Funds**

The Department of Finance, Office of State Audits and Evaluations, has completed its audit of the California State Coastal Conservancy's (Conservancy) Propositions 12, 13, 40, and 50 bond funds for the period ending June 30, 2008.

Staff Project Manager Mary Small **failed to require Potential Grantee**, the Santa Monica Bay Restoration Foundation, **to fill out a Grant Application Form** on the Conservancy Website.

**Background:**

On January 24, 2011 The **California Department of Finance Issued a Final Report – Audit** of the California State Coastal Conservancy. The Report Found that ;

*The Conservancy did not establish formal program guidelines: project awarding criteria; and **grant applications** to document its project merit review process. Also, the Conservancy website included limited or incomplete information about ongoing programs and efforts, regional priorities, and **funding opportunities**.*

On October 7, 2010, Executive Director Samuel Schuchat responded to the Audit.

*The Conservancy website has been updated to included the **standardized grant application**, more information about funding opportunities.*

*The Conservancy has formally adopted project selection criteria, and a formal, transparent awarding process that follows statute.*

*It generally does not institute grant rounds but instead has an **open grant process**. **Application can be and are made, and these are considered at any time.***

*With respect to the form of **grant applications**, based on discussions with the auditors, we have created a **uniform grant application** that is posted on our website. There is now more information available to the public concerning priorities and how to apply for funding.*

*We have developed a **standard grant application that is now in use**.*

A. Staff Project Manager Mary Small failed to obtain any written documentation to identify the Potential Grantee, no address, no agent name, nor an account to which the grant could be deposited is recorded.

B. Staff Project Manager Mary Small had no paperwork whatsoever from the Potential Grantee prior to January 19, 2012 nor did the Potential Grantee request funding. Staff did not provide public notice that such Grant Funds were available to other qualified entities.

C. Staff Project Manager Mary Small failed to determine if the private business, Santa Monica Bay Restoration Foundation was legally operating out of a State Water Board Office, the Los Angeles Regional Water Quality Control Board. Filings with the California Secretary of State show the private business is operating out of a State Office. There is no legal authority allowing for this.

D. Staff Project Manager Mary Small failed to disclose the fact she was a Director of the Corporation of the Proposed Grantee in 2006 creating an appearance of impropriety.

## **2. FALSEFICATION OF PUBLIC RECORDS ATTACHMENT 2**

Staff falsified a Form SCC 08-08, Work Transmittal.

The Form was initialized by;  
Executive Director - Sam Schuchat  
Project Manager - Mary Small  
Legal - Elena Eger

Staff filled out the form as follows:

*Will this project receive federal or other outside funding? Yes \_\_\_ No X*

The January 19, 2012 **Staff Report contradicts on page 6 :**

*“The SMRBF in-kind funds would come from U.S. EPA funding provided to the SMRBF for its staff and from a U.S. EPA Wetland Program Development Grant received for work at Ballona”*

## **3. INCOMPLETE PUBLIC RECORDS ATTACHMENT 2**

Staff failed to complete Form SCC 08-08, Work Transmittal.

The Form was initialized by;  
Executive Director - Sam Schuchat  
Project Manager - Mary Small  
Legal - Elena Eger

*Is the Grantee a Nonprofit Organization Yes \_\_\_ No \_\_\_ - NOT CHECKED*  
*If nonprofit: Is the status file complete and current Yes \_\_\_ No \_\_\_ - NOT CHECKED*  
*GRANT / CONTRACT AMMENDMENTS REVIEW - BLANK*  
*MAIL OUT APPROVALS - BLANK*  
*APPLICATION - BLANK*  
*GRANT TRANSMITTAL - BLANK*  
*REVIEW OF AGREEMENT - BLANK*

## **4. DISCRIMINATION ATTACHMENT 3**

Staff Project Manager Mary Small has improperly lobbied private individuals, private businesses, State and Federal Officials and entities prior to the release of the Staff Report, thusly, discriminating against all others by failing to provide the same comment opportunity prior to the issuance of the Staff Report.

Further Discrimination has taken place because only one Potential Grantee has been selected by Staff Project Manager Mary Small, excluding all others that may have chosen to apply.

Moreover, Discrimination has taken place in that only a select group of Potential contractors was noticed by Staff Project Manager Mary Small, in non-compliance with the California Contract Code, excluding all other qualified firms.

#### **5. PREJUDICE OF PROCESS ATTACHMENT 4**

Staff Project Manager Mary Small requested Potential Grantee to help write Staff Report.

Staff Project Manager Mary Small worked with Potential Grantee to engage in media spin to avoid scrutiny.

#### **6. STAFF REPORT EXCLUDED VITAL INFORMATION ATTACHMENT 5**

The Staff Report is ambiguous. It describes the Grantee in detail with no supporting documentation whatsoever.

The Staff Report does not establish terms of compliance for the Proposed Grantee nor for entities that will complete the described studies.

The Staff Report does not define that contractors will be hired. Staff Project Manager Mary Small discussed hiring contractors with the Potential Grantee and others before the Staff Report was approved, purposely avoiding the requirement under the Bagley Keene Act for the Governing Board to approve contractors and Notice requirements of the California Contract Code.

Legal Staff Elena Eger encouraged Staff Project Manager Mary Small to complete a grant agreement form because I requested it pursuant to the Public Records Act. The form should have been completed without my request for it.

The Staff Report failed to inform this Board that a Federal Environmental Protection Act Process was initiated by the Army Corp of Engineers Los Angeles in 2005 that governs the Ballona Wetlands.

Staff has failed to inform the Governing Board and Public that the Project Manager, Mary Small, lobbied the Department of Fish and Game to ignore the EIS Notice published in the Federal Register, in favor of a new EIR/EIS process desired by the Project Manager and the Proposed Grantee, without informing and seeking authorization from this Governing Board. This clearly constitutes interference with a legally noticed federal NEPA process. Furthermore Staff Project Manager Mary Small failed to inform this Governing Board that the entire area is governed by U.S. Public Law 780, the Rivers and Harbors Act of 1954, which is the subject of the EIS process currently being conducted by the USACE.

In the Minutes of the Ballona Ecosystem Restoration Planning Management Committee, obtained from the USACE by FOIA Staff Project Manager Mary Small, without the

authorization of this Board, represented to the Army Corp of Engineers on June 28, 2010 that:

*Coastal Conservancy is supplying most of the funding toward the in-kind local sponsor efforts.*

The Governing Board has not authorized Mary Small to represent the Coastal Conservancy at a meeting of the Army Corp of Engineers and the Local Sponsor (Santa Monica Bay Restoration Authority). The Conservancy is neither a partner nor is there any MOU to with the SMRBA, which is under contract to the USACE. Minutes of other such meetings provide evidence that Mary Small also discussed;

A. Changing the scoping of an Environmental Protection Act process began by the USACE in 2005.

B. Using only the Conservancy's Alternatives.

C. Attempting to gain in kind credits from the USACE.

D. Further documents provided by the USACE provide evidence that the local sponsor, never provided any funding to the USACE whatsoever nor did it provide any in-kind credit.

E. Resumes provided to the Coastal Conservancy by potential contractors for this Project include studies finished and paid for by federal funding stated in the resume(s) as part of the Lower Ballona Creek Feasibility Studies of the Joint EIR/EIS (2005) initiated by the USACE.

#### **7. VIOLATIONS OF CALIFORNIA CONTRACT CODE ATTACHMENT 6**

Staff Project Manager Mary Small failed to comply with the California Contract Code Notification and Conflict requirements, Sections 10140-10141 and 10515-10518.

Staff Project Manager Mary Small conducted a Request for Services for Contractors in 2009, and again in 2010 in regard to a Project not noticed to the Public or Governing Board until 2012, both in non-compliance with California Contract Code.

Staff Project Manager Mary Small purports to have initiated another Request for Services in February 2012 with responses due on the 29<sup>th</sup> of that month outside in non-compliance with the California Contract Code.

#### **8. VIOLATIONS OF BAGLEY KEENE ATTACHMENT 6**

Staff failed to obtain permission from the Governing Board to hire contractors to complete studies.

#### **9. QUID PRO QUO INFERED ATTACHMENT 7**

The attached e-mails contain an inference of a quid pro quo. The request for a support letter is accompanied by a discussion of bond money provisions. In one email a support letter request exists alongside a discussion to close out another matter, without specificity.

**10. INIMIDATION AND HARRASSNMENT OF PUBLIC BY LEGAL STAFF  
VIOLATING STATE LAW AND AGENCIES PRIVACY POLICY  
ATTACHMENT 8**

Legal Staff Elena Eger has attempted to intimidate and harass me by copying private business persons on emails to me which disclose my private address, even after I requested the practice cease in writing, in clear contradiction to Information Practices Act (Civil Code section 1798 et seq.) and the Agencies Privacy Policy.

Staff has violated the Conservancy Privacy Policy by the aforesaid action(s).

***Privacy Policy***

*Pursuant to Government Code § 11019.9, all departments and agencies of the State of California shall enact and maintain a permanent privacy policy, in adherence with the Information Practices Act of 1977 (Civil Code § 1798 et seq.), that includes, but is not necessarily limited to, the following principles:*

- (a) Personally identifiable information may only be obtained through lawful means.*
- (b) The purposes for which personally identifiable data are collected shall be specified at or prior to the time of collection, and any subsequent use of the data shall be limited to and consistent with the fulfillment of those purposes previously specified.*
- (c) Personal data may not be disclosed, made available, or otherwise used for a purpose other than those specified, except with the consent of the subject of the data, or as required by law or regulation.*
- (d) Personal data collected shall be relevant to the purpose for which it is needed.*
- (e) The general means by which personal data is protected against loss, unauthorized access, use, modification, or disclosure shall be posted, unless the disclosure of those general means would compromise legitimate agency objectives or law enforcement purposes.*

***Each department shall implement this privacy policy by:***

- Designating which position within the department or agency is responsible for the implementation of and adherence to this privacy policy;*
- Prominently posting the policy physically in its offices and on its internet website, if any;*
- Distributing the policy to each of its employees and contractors who have access to personal data;*
- Complying with the Information Practices Act (Civil Code § 1798 et seq.); the Public Records Act (Government Code § 6250 et seq.); Government Code § 11015.5, and all other laws pertaining to information privacy;*
- Using appropriate means to successfully implement and adhere to this privacy policy.'*



Sincerely,

A handwritten signature in black ink, appearing to read "John Davis". The signature is written in a cursive style with a large, prominent loop at the beginning of the first name.

John Davis  
PO 10152  
Marina del Rey Ca. 90295

**ATTACHMENT 1**

RE: Public Records Request from John Davis

**From:** Philip Wyels <PWyels@waterboards.ca.gov> (Add as Preferred Sender)  
**Date:** Tue, Feb 21, 2012 2:26 pm  
**To:** <jd@johnanthonydavis.com>

Mr. Davis, I apologize for the delay in responding to your request. I have been unable to locate any records within the possession of the State Water Resources Control Board that are responsive to your requests. The attached two documents may be of interest to you, however, in that they indicate that the Santa Monica Bay Restoration Project's relationship with the Santa Monica Bay Restoration Foundation (Foundation) pre-dated the conversion of the Santa Monica Bay Restoration Project to the Santa Monica Bay Restoration Commission (Commission). Also, as I explained to you by telephone, the Commission staff is currently undertaking a number of steps to more clearly distinguish the Commission from the Foundation. Unfortunately, some of those steps are taking some time. I will let you know when I receive a timetable for those steps from Commission staff.

Sincerely,  
Phil

Philip G. Wyels  
Assistant Chief Counsel  
State Board Water Quality Unit  
State Water Resources Control Board

1001 I Street  
P.O. Box 95812-0100  
Sacramento, CA 95814

(916) 341-5178 (phone)  
(916) 341-5199 (fax)  
[pwyls@waterboards.ca.gov](mailto:pwyls@waterboards.ca.gov)>>>

**From:** <jd@johnanthonydavis.com>  
**To:** Philip Wyels <pwyls@waterboards.ca.gov>  
**CC:** Michael Lauffer <MLauffer@waterboards.ca.gov>  
**Date:** 2/21/2012 10:00 AM  
**Subject:** RE: Public Records Request from John Davis

California State Water Board  
Att: Phil Wyels  
Re: Status Request Public Record Request

Council Wyels,

The California Public Records Act requires that Agencies subject to the Act reply to request for records within 10 days after a request is made.

The State Water Resources Board has not complied with the law in this respect in regard to the request for records made on 2/7/12.

Please advise as to if or when the State Agency will reply.

Thanks,

John Davis

----- Original Message -----

Subject: Public Records Request from John Davis  
From: <jd@johnanthonydavis.com>  
Date: Tue, February 07, 2012 3:03 pm  
To: "Philip Wyels" <pwyls@waterboards.ca.gov>  
Cc: "Elena Eger" <eeger@scc.ca.gov>

California State Water Board  
Att: Phil Wyels  
Re: Public Record Request

Dear Mr. Wyeles,

This is a request for public records pursuant to the California Public Records Act. Each numbered request is distinct.

1. Please provide any record of any law, regulation, or policy of the State Water Board which allows a private business to operate out of a State Water Board Office.
2. Please provide any record of any law, regulation, or policy that allows a private business to use a State Water Board Office as a corporate street address of principal office in California, and or as a mailing address of the corporation, and or mailing address of the corporation, and or address of a corporate Chief Executive Officer, and or of a corporate secretary, and or of a corporate financial agent.
3. Please provide any law, and or regulation, and or policy that allows any State Water Board Commission to designate a private business as its "FISCAL AGENT"
4. Please provide any law, and or regulation, and or policy that allows any State Water Board Commission to designate a private business to receive, manage, and to treat money granted by the U.S. Government to the State of California as revenue of the private business.

Thank you for your continued assistance,

John Davis  
PO 10152  
Marina del Rey Ca. 90295  
310.795.9640

**From:** [Elena Eger](#)  
**To:** "[ed@johnanthonydavis.com](mailto:ed@johnanthonydavis.com)"  
**Cc:** "[Shelley Luce](#)"; "[svolor@santamonibay.org](mailto:svolor@santamonibay.org)"; "[Mary Small](#)"; "[Dick Wayman](#)"; "[Nadine Peterson](#)"; "[Samuel Schuchat](#)"  
**Subject:** Davis call to Eger of 2-6-12  
**Date:** Tuesday, February 07, 2012 1:00:00 PM  
**Attachments:** [SWRCB memo 2011 aug re accusations.pdf](#)  
[SWRCB Ltr to Davis re PRAs.pdf](#)

---

Dear Mr. Davis:

Pursuant to our phone conversation of yesterday, February 6, 2012, in which you provided a warning to me that the Conservancy should be informed that the Santa Monica Bay Foundation allegedly is appropriating public resources for private gain, attached please find the State Water Resources Control Board's (SWRCB) August 15, 2011 legal memo addressing your contentions and a September 13, 2011 letter to you regarding the same.

As analyzed in the SWRCB memo, especially in #3, pp. 4-5 of that memo, your contentions that the Foundation is improperly utilizing public resources for private use, namely in your assertions yesterday when you identified as improper the fact that the Foundation uses the same mailing address as the SWRCB's Los Angeles office, are specifically addressed. Frances McChesney, Esq., Office of the Chief Counsel for the SWRCB concludes in that memo that the Foundation is not improperly appropriating public resources for its private use.

The Conservancy intends to proceed with its grant to the Foundation approved as Item #5 at its January 19, 2012 meeting.

Sincerely,

Elena Eger  
Senior Staff Counsel  
California Coastal Conservancy  
1330 Broadway, Ste. 1300  
Oakland, CA 94612  
510-286-4089 tele/voicemail  
510-286-0470 fax

**State of California**  
**Secretary of State**



E-945038

**FILED**

In the office of the Secretary of State  
of the State of California

**Feb - 5 2010**

This Space For Filing Use Only

**STATEMENT OF INFORMATION**

(Domestic Nonprofit, Credit Union and Consumer Cooperative Corporations)

Filing Fee \$20.00. If amendment, see instructions.

**IMPORTANT - READ INSTRUCTIONS BEFORE COMPLETING THIS FORM**

1. CORPORATE NAME (Please do not alter if name is preprinted.)				<b>N</b>
C1481142 SANTA MONICA BAY RESTORATION FOUNDATION				
320 W 4TH ST STE 200 LOS ANGELES CA 90013				
<b>DUE DATE:</b>				
<b>COMPLETE PRINCIPAL OFFICE ADDRESS (Do not abbreviate the name of the city. Item 2 cannot be a P.O. Box.)</b>				
2. STREET ADDRESS OF PRINCIPAL OFFICE IN CALIFORNIA, IF ANY	CITY	STATE	ZIP CODE	
320 W 4TH ST STE 200	LOS ANGELES	CA	90013	
3. MAILING ADDRESS OF THE CORPORATION, IF REQUIRED	CITY	STATE	ZIP CODE	
320 W 4TH ST STE 200	LOS ANGELES	CA	90013	
<b>NAMES AND COMPLETE ADDRESSES OF THE FOLLOWING OFFICERS (The corporation must have these three officers. A comparable title for the specific officer may be added; however, the preprinted titles on this form must not be altered.)</b>				
4. CHIEF EXECUTIVE OFFICER/	ADDRESS	CITY	STATE	ZIP CODE
SHELLY LUCE	320 W 4TH ST STE 200	LOS ANGELES, CA	90013	
5. SECRETARY/	ADDRESS	CITY	STATE	ZIP CODE
CATHERINE TYRRELL	320 W 4TH ST STE 200	LOS ANGELES	CA	90013
6. CHIEF FINANCIAL OFFICER/	ADDRESS	CITY	STATE	ZIP CODE
LAURIE NEWMAN	320 W 4TH ST STE 200	LOS ANGELES	CA	90013
<b>AGENT FOR SERVICE OF PROCESS (If the agent is an individual, the agent must reside in California and Item 8 must be completed with a California street address (a P.O. Box address is not acceptable). If the agent is another corporation, the agent must have on file with the California Secretary of State a certificate pursuant to Corporations Code section 1505 and Item 8 must be left blank.)</b>				
7. NAME OF AGENT FOR SERVICE OF PROCESS				
SHELLEY LUCE				
8. STREET ADDRESS OF AGENT FOR SERVICE OF PROCESS IN CALIFORNIA, IF AN INDIVIDUAL	CITY	STATE	ZIP CODE	
320 W 4TH ST STE 200	LOS ANGELES, CA	90013		
<b>DAVIS-STIRLING COMMON INTEREST DEVELOPMENT ACT (California Civil Code section 1350, et seq.)</b>				
9. <input type="checkbox"/> Check here if the corporation is an association formed to manage common interest development under the Davis-Stirling Common Interest Development Act and proceed to items 10, 11 and 12.				
<b>NOTE:</b> Corporations formed to manage a common interest development must also file a Statement by Common Interest Development Association (Form SI-CID) as required by California Civil Code section 1363.6. Please see instructions on the reverse side of this form.				
10. ADDRESS OF BUSINESS OR CORPORATE OFFICE OF THE ASSOCIATION, IF ANY	CITY	STATE	ZIP CODE	
11. FRONT STREET AND NEAREST CROSS STREET FOR THE PHYSICAL LOCATION OF THE COMMON INTEREST DEVELOPMENT (Complete if the business or corporate office is not on the site of the common interest development.)				
12. NAME AND ADDRESS OF ASSOCIATION'S MANAGING AGENT, IF ANY	CITY	STATE	ZIP CODE	
13. THE INFORMATION CONTAINED HEREIN IS TRUE AND CORRECT.				
02/05/2010	SHELLEY LUCE	EXECUTIVE DIRECTOR		
DATE	TYPE OR PRINT NAME OF PERSON COMPLETING THE FORM	TITLE	SIGNATURE	
SI-100 (REV 01/2008)				APPROVED BY SECRETARY OF STATE

**Return of Organization Exempt From Income Tax**  
 Under section 501(c), 527, or 4947(a)(1) of the Internal Revenue Code (except black lung benefit trust or private foundation)

Department of the Treasury  
 Internal Revenue Service

The organization may have to use a copy of this return to satisfy state reporting requirements

**A** For the 2006 calendar year, or tax year beginning Jul 01, 2006, and ending Jun 30, 2007

**B** Check if applicable:  
 Address change  
 Name change  
 Initial return  
 Final return  
 Amended return  
 Application pending

**C** Name of organization, number and street, city, town, state, and ZIP code:  
 Santa Monica Bay Restoration Foundation  
 320 West 4th Street Suite 200  
 LOS ANGELES CA 90013

**D** Employer identification number: 33-0420271

**E** Telephone number: 213-576-6642

**F** Acctg. method:  Cash  Accrual  
 Other (specify) \_\_\_\_\_

**G** Website: WWW.SANTAMONICABAY.ORG

**J** Organization type (check only one):  501(c)(3) (insert no) \_\_\_\_\_ 4947(a)(1) or 527 \_\_\_\_\_

**K** Check here  if the organization is not a 509(a)(3) supporting organization and its gross receipts are normally not more than \$25,000. A return is not required, but if the organization chooses to file a return, be sure to file a complete return.

**H** and **I** are not applicable to section 527 organizations  
**H(a)** Is this a group return for affiliates?  Yes  No  
**H(b)** If "Yes," enter number of affiliates: \_\_\_\_\_  
**H(c)** Are all affiliates included? (If "No," attach a list. See instructions.)  Yes  No  
**H(d)** Is this a separate return filed by an organization covered by a group ruling?  Yes  No  
**I** Group Exemption Number: \_\_\_\_\_

**M** Check  if the organization is not required to attach Sch. B (Form 990, 990-EZ, or 990-PF)

**L** Gross receipts. Add lines 6b, 8b, 9b, and 10b to line 12: 979,681.

**Part I Revenue, Expenses, and Changes in Net Assets or Fund Balances** (See the instructions)

<b>1</b> Contributions, gifts, grants, and similar amounts received					
a Contributions to donor advised funds		1a			
b Direct public support (not included on line 1a)		1b	342,406.		
c Indirect public support (not included on line 1a)		1c			
d Government contributions (grants) (not included on line 1a)		1d	576,050.		
e Total (add lines 1a through 1d) (cash \$ <u>918,456.</u> noncash \$ _____)		1e		918,456.	
<b>2</b> Program service revenue including government fees and contracts (from Part VII, line 93)		2		18,485.	
<b>3</b> Membership dues and assessments		3			
<b>4</b> Interest on savings and temporary cash investments		4		41,773.	
<b>5</b> Dividends and interest from securities		5		967.	
<b>6</b> a Gross rents		6a			
b Less rental expenses		6b			
c Net rental income or (loss). Subtract line 6b from line 6a		6c			
<b>7</b> Other investment income (describe: _____)		7			
<b>8</b> a Gross amount from sales of assets other than inventory		8a			
b Less cost or other basis & sales expenses		8b			
c Gain or (loss) (attach schedule)		8c			
d Net gain or (loss). Combine line 8c, columns (A) and (B)		8d			
<b>9</b> Special events and activities (attach schedule). If any amount is from gaming, check here <input type="checkbox"/>					
a Gross revenue (not including \$ _____ of contributions reported on line 1b)		9a			
b Less direct expenses other than fundraising expenses		9b			
c Net income or (loss) from special events. Subtract line 9b from line 9a		9c			
<b>10</b> a Gross sales of inventory, less returns and allowances		10a			
b Less cost of goods sold		10b			
c Gross profit or (loss) from sales of inventory (attach schedule). Subtract line 10b from line 10a		10c			
<b>11</b> Other revenue (from Part VII, line 103)		11			
<b>12</b> Total revenue. Add lines 1e, 2, 3, 4, 5, 6c, 7, 8d, 9c, 10c, and 11		12		979,681.	
<b>13</b> Program services (from line 44, column (B))		13		757,878.	
<b>14</b> Management and general (from line 44, column (C))		14		102,224.	
<b>15</b> Fundraising (from line 44, column (D))		15		7,373.	
<b>16</b> Payments to affiliates (attach schedule)		16			
<b>17</b> Total expenses. Add lines 16 and 44, column (A)		17		867,475.	
<b>18</b> Excess or (deficit) for the year. Subtract line 17 from line 12		18		112,206.	
<b>19</b> Net assets or fund balances at beginning of year (from line 73, column (A))		19		872,326.	
<b>20</b> Other changes in net assets or fund balances (attach explanation)		20			
<b>21</b> Net assets or fund balances at end of year. Combine lines 18, 19, and 20		21		984,532.	

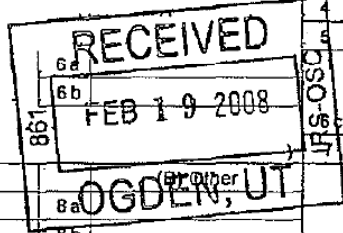

SCANNED MAR 04 2008

97

**List of Officers, Directors, Trustees and Key Employees**

**US 990      990: Page 5, Part V; 990EZ: Page 2 Part IV; 990-PF: Page 6, Part VIII      2006**

Name and Address	Title/Average Hours Per Week Devoted to Position	Amount Paid	Amount for Employee Benefit Plan	Expense Account and Other Allowances
Rod Spackman 320 W 4th St	President 2			
Randal Orton 320 W 4th St	CFO 2			
Mark Gold 320 W 4th St	Director 1			
Tom Ford 320 W 4th St	Director 1			
Richard Bloom 320 W 4th St	Director 1			
Fran Diamond 320 W 4th St	Director 1			
Marvin Sachse 320 W 4th St	Director 1			
Bob Hoffman 320 W 4th St	Director 1			
S Wisniewski 320 W 4th St	Director 1			
Laurie Newman 320 W 4th St	Director 1			
Mary Small 320 W 4th St	Director 1			
Bryant Chesney 320 W 4th St	Director 1			
Dean Kubani 320 W 4th St	Director 1			
Shelley Luce 320 W 4th St	Executive 40	55,830.		
		55,830.		



## ATTACHMENTS 2

## WORK TRANSMITTAL

### Project Development Approval

Date: 12/13/11 WG Leader: MS Date: 12/13/11  
 Project Manager: Mary Small Project #: 04-088-01  
 Project Name: Ballena Wetlands County/City: LA<sup>2</sup>  
 Grantee/Contractor Name: abd / Santa Monica Bay Foundation  
 Is Grantee a Nonprofit Organization?  Yes  No If Nonprofit: Is status file complete and current?  Yes  No  
 Nature of Job: planning / design

### RESERVATION OF FUNDS

Will this project receive federal or other "outside" funding?  Yes  No. If Yes, fill out back side of this form (Grant Transmittal - A)  
 Will this project receive state / other funding?  Yes (Reimb. -0995)  No. If Yes, fill out back side of this form (Grant Transmittal - B)

Total Amount to be Reserved: \$ 6,490,000.00  
 Prop 84-Planning?  Yes  No

Proposed Budget Item(s):	Fiscal Year (Budget Act)	Amount	Encumb. Liquid. Expiration Date
1. 3760- <u>30203-0005</u> (2)(B)( )	<u>2000</u> Chapter: <u>057</u>	\$ <u>6,490,000.00</u>	( <u>6/13</u> )( <u>6/15</u> )
2. 3760-_____ ( ) ( ) ( )	Chapter: _____	\$ _____	( ) ( )
3. 3760-_____ ( ) ( ) ( )	Chapter: _____	\$ _____	( ) ( )

Reap. by Chapter: 712/10 for item 1 Reap. by Chapter: \_\_\_\_\_ for item \_\_\_\_\_ Reap. by Chapter: \_\_\_\_\_ for item \_\_\_\_\_

Program: enhancement Project Info entered onto applicable Bond Data Spreadsheet?  Y  X  N Date: MA  
 Public Access: VRA (Capital Outlay)  
 Habitat Conservation Fund (0262)  
 Support: 001 Fund 0565 only:  Yes  
 IF  Consult & Prof. (External)  (Inter-Dept)  
 Repayment Feature? (Loan Receivable)  Yes  No  
 Private Activity?  Yes  No  N/A  
 (Tax Reportable to Treasurer's Office)

Expected Date of Board Action: 4/19/12 Project Entered onto SCC Database?  Y  N Date: 12/13/11  
 1. WG Leader: MS Date: 12/13/11 4. Legal: EE Date: 12/14/11  
 2. Acctg Officer: HT 6.49M Date: 12/13/11 5. EO/DEO: SS Date: 12/15/11  
 3. Additional WG Leader responsible for management of specific funds (if applicable): \_\_\_\_\_ Date: \_\_\_\_\_

### STAFF RECOMMENDATION REVIEW (For 1/19/12 Board Meeting)

1. WG Leader: MS Date: 12/13/11 3. EO/DEO: SS Date: 12/15/11  
 2. Legal: EE Date: 12/14/11 4. \*Legal: \_\_\_\_\_ Date: \_\_\_\_\_  
\* At EO/DEO's discretion

### GRANT/CONTRACT AMENDMENTS REVIEW

(CEQA Submitted?  Yes  No  N/A Project Manager \_\_\_\_\_ Date: \_\_\_\_\_)  
 Amount Encumbered: \$ \_\_\_\_\_ Grant/Contract No.: \_\_\_\_\_  
 Termination Date: \_\_\_\_\_ Amendment No.: \_\_\_\_\_  
 Disabled Veteran Business Enterprise (DVBE)?  Yes  No 20-yr Agreement?  Yes  No  
 Small Business Enterprise (SBE)?  Yes  No  
 (If Yes, provide OSD# \_\_\_\_\_)

### MAIL OUT APPROVALS

1. Legal: \_\_\_\_\_ Date: \_\_\_\_\_ 2. Project Manager: \_\_\_\_\_ Date: \_\_\_\_\_  
 3. Proofreader: \_\_\_\_\_ Date: \_\_\_\_\_

# GRANT TRANSMITTAL

Grant No. \_\_\_\_\_

(for receivable grants)

## INTENT TO APPLY

Date: \_\_\_\_\_

Project Manager: \_\_\_\_\_

SCC Program: \_\_\_\_\_

Grant Amount: \_\_\_\_\_

Grant Program Name: \_\_\_\_\_

Granting Agency: \_\_\_\_\_

Project Name: \_\_\_\_\_

Project Number: \_\_\_\_\_

SCC required Matching Funds: (if other than in-kind services, please use reverse side of this form to reserve SCC funds)

In - Kind: \$ \_\_\_\_\_

( Copy from reverse side)

Support: \$ \_\_\_\_\_

Fund No.: \_\_\_\_\_ FY: \_\_\_\_\_

Capital Outlay: \$ \_\_\_\_\_

Fund No.: \_\_\_\_\_ FY: \_\_\_\_\_

TOTAL: \$ \_\_\_\_\_

Funding Mechanism: \_\_\_\_\_ Will or will not hit SCC account? \_\_\_\_\_ Electronic Transfer? \_\_\_\_\_

Paid in Arrears? \_\_\_\_\_ Cash Advance? \_\_\_\_\_

### (A) For Federal Grant

Support (Staff, travel, equipment): \$ \_\_\_\_\_ 3760 - 001 - 0890 FY: \_\_\_\_\_

Capital Outlay: \$ \_\_\_\_\_ 3760 - 301 - 0890 FY: \_\_\_\_\_

Other (Specify) \_\_\_\_\_: \$ \_\_\_\_\_ 3760 - \_\_\_\_\_ FY: \_\_\_\_\_

TOTAL: \$ \_\_\_\_\_

### (B) For State Reimbursable Grant (Please use reverse side of this form to reserve up-front SCC funds)

Support (Staff, travel, equipment): \$ \_\_\_\_\_ 3760 - 001 - 0555 - F90 FY: \_\_\_\_\_

Capital Outlay: \$ \_\_\_\_\_ 3760 - 301 - \_\_\_\_\_ - F90 FY: \_\_\_\_\_

Other (Specify) \_\_\_\_\_: \$ \_\_\_\_\_ 3760 - \_\_\_\_\_ - \_\_\_\_\_ - F90 FY: \_\_\_\_\_

TOTAL: \$ \_\_\_\_\_

### Authorization:

Program Manager: \_\_\_\_\_ Date: \_\_\_\_\_

Accounting Officer: \_\_\_\_\_ Date: \_\_\_\_\_

Grants Manager: \_\_\_\_\_ Date: \_\_\_\_\_

## APPLICATION (Provide copy of Application to Grants Manager)

Legal \* \_\_\_\_\_ Date: \_\_\_\_\_

\*Please inform Grants Manager if signature are missing in the "INTENT TO APPLY" SECTION

EO/DEO: \_\_\_\_\_ Date: \_\_\_\_\_

Date Applied: \_\_\_\_\_ Expected Date of Grant Award: \_\_\_\_\_

## REVIEW OF AGREEMENT (for receipt of funds)

### Board Authorization To Spend The Grant:

Date (s): \_\_\_\_\_

Project Manager: \_\_\_\_\_ Date: \_\_\_\_\_

Program Manager: \_\_\_\_\_ Date: \_\_\_\_\_

Legal: \_\_\_\_\_ Date: \_\_\_\_\_

EO/DEO: \_\_\_\_\_ Date: \_\_\_\_\_

Grants Manager: \_\_\_\_\_ Date: \_\_\_\_\_

Amendment #: \_\_\_\_\_

Legal Reviewed by: \_\_\_\_\_ Inform Acct. Date: \_\_\_\_\_

Date: \_\_\_\_\_

**ATTACHMENT 3**

**From:** Mary Small  
**To:** [sluce@santamonica.gov](mailto:sluce@santamonica.gov); "Barbara Romero"  
**Subject:** FW: hard copy in the mail tomorrow  
**Date:** Friday, January 06, 2012 4:04:00 PM

---

-----Original Message-----

From: Ruth Galanter [<mailto:ruth.galanter@verizon.net>]  
Sent: Friday, January 06, 2012 3:57 PM  
To: Mary Small  
Subject: Re: hard copy in the mail tomorrow

I am planning to attend the meeting, and I'm trying to get some more support letters and maybe attendees. You have no idea how much pleasure I would get from foiling your opponents. I can either stand up during the hearing, or if you want, I can instead meet you and the board between the tour and the meeting (since you must be going to feed them someplace) and just chat informally.

Your choice. I'm free at about 11:30 and have a meeting at 3 pm. In between I am at your service.

On Jan 6, 2012, at 3:50 PM, Mary Small wrote:

> Thanks that's a very generous offer. If you have time to attend the  
> meeting, that would be great. It starts at 1pm at Baldwin Hills Scenic  
> Overlook and this is the first substantive item on the agenda. I will have  
> pretty limited time to present, but could acknowledge you and if you were  
> willing to speak in public comment on the item that would fantastic.  
> Mary

>  
> -----Original Message-----  
> From: Ruth Galanter [<mailto:ruth.galanter@verizon.net>]  
> Sent: Friday, January 06, 2012 9:52 AM  
> To: Mary Small  
> Subject: Re: hard copy in the mail tomorrow

>  
> I'm available after about 11:30, and you might want to use me as part of a  
> board briefing in light of my nearly two decades dealing with the issue.  
> That of course is up to you, and I promise not to get huffy if you'd rather  
> not.

> On Jan 6, 2012, at 9:10 AM, Mary Small wrote:

>> Thank you very much, your letter is perfect and I appreciate your quick  
>> response. It would be great to have a few supporters at the meeting, I am  
>> sure the opponents will attend.

>>  
>> We are also going to take the Coastal Conservancy board on a quick tour of  
>> the site the morning before the meeting from 10-12. I know you are very  
>> busy but it would be great if you wanted to join us for either the tour or  
>> to attend the meeting.  
>> Mary

>>  
>> -----Original Message-----  
>> From: Ruth Galanter [<mailto:ruth.galanter@verizon.net>]  
>> Sent: Thursday, January 05, 2012 9:13 PM  
>> To: Small Mary  
>> Subject: hard copy in the mail tomorrow  
>>

>> Hi Mary,  
>>  
>> I've emailed you my letter and will send the hard copy tomorrow.  
>>  
>> I've also emailed various people to suggest attending the hearing in case  
>> the eco-loonies show up, as I suppose they will.  
>>  
>> Have a good weekend.  
>>  
>> Ruth  
>>  
>>  
>>  
>  
>  
>  
>

**From:** Mary Small  
**To:** "Shelley Luce"  
**Subject:** FW: Letter for Coastal Conservancy Board  
**Date:** Tuesday, December 13, 2011 1:21:00 PM

---

Do you know Ruth?

---

**From:** Joan Cardellino [mailto:jcard@scc.ca.gov]  
**Sent:** Tuesday, December 13, 2011 11:57 AM  
**To:** 'Mary Small'  
**Subject:** RE: Letter for Coastal Conservancy Board

It might be worth calling Ruth Galanter to see if she'd speak in support of the project. She has some good credentials. She might know of other supporters to ask too.

---

**From:** Mary Small [mailto:msmall@scc.ca.gov]  
**Sent:** Tuesday, December 13, 2011 10:38 AM  
**To:** 'Shelley Luce'  
**Cc:** 'Joan Cardellino (Joan Cardellino)'  
**Subject:** RE: Letter for Coastal Conservancy Board

Hi Shelley-

Do you have time to talk about our Jan meeting? I know you have a board meeting this week, so we could also do this via email – or next week, but before next Fri I'd like to work through some ideas:

- 1) Tour – we'll probably do a tour the morning of the meeting, I think maybe the tour we did with Colonel Toy – view from Cabora Rd and then walk out to boyscout platform
- 2) Press – do you think we could use this meeting as an opportunity to get either local papers and/or try for LA Times to cover the project? I am worried that once the agenda is out Marcia will use as opportunity to get bad press. Our agenda will be mailed out Jan 6<sup>th</sup>
- 3) Public support – who could we have come to support the project at the meeting or with letters? Geraldine is critical (at least her letter) but how about MRCA?, Joe Geever?, Ballona Creek Renaissance?, Friends?, Miguel Luna?, Audubon? HtB? Baykeeper?

Thanks,  
Mary

---

**From:** Shelley Luce [mailto:sluce@santamonicabay.org]  
**Sent:** Monday, December 12, 2011 3:22 PM  
**To:** Mary Small  
**Subject:** FW: Letter for Coastal Conservancy Board

Hi Mary, Geraldine thought her letter went out already. Have you received? I also invited her to tour the wetlands with us after the meeting.

*Shelley Luce, D.Env.  
Executive Director  
Santa Monica Bay Restoration Commission*

**From:** [Mary Small](#)  
**To:** ["Bryant Chesney"](#)  
**Cc:** ["sluce@santamonibabay.org"](mailto:sluce@santamonibabay.org)  
**Subject:** FW: support letter for Ballona Funding  
**Date:** Friday, January 06, 2012 9:57:00 AM  
**Attachments:** [Ballona Wetlands Engineering and Technical Studies.docx](#)  
[ballona support letter 1.docx](#)  
[ballona support letter 2.docx](#)

---

Hi Bryant

I was wondering if you would be willing to send a letter of support (samples attached) to the Coastal Conservancy for the Ballona wetlands project. Also attached is the draft staff recommendation. The Conservancy will be considering this authorization in LA on Jan 19th, we will take the board on a quick tour of the site before the meeting. If you have time, it would be great to have you attend either of those events too.

This is the request for all funding to complete the environmental review, 100% engineering, and all of the hydrology/hydraulics modeling that the Army Corps is requiring for its permit to modify the flood control levees. The later analysis is the about half of the cost estimate.

Since the meeting will be in LA, opponents of the project are likely to show up. This approval is pretty critical to moving the project forward. If the Conservancy Board gets frightened away from large scale, ecological restoration then I think we will have very limited options for the future.

Thanks for your consideration and please let me know if you have any questions.  
Mary



**From:** [Mary Small](#)  
**To:** "[Miguel Luna](#)"  
**Cc:** "[Shelley Luce](#)"  
**Subject:** FW: draft support letter for SCC board meeting  
**Date:** Tuesday, January 03, 2012 1:29:00 PM  
**Attachments:** [SCC Ballona Tech Support Ltr.docx](#)

---

Hi Miguel

Happy New year! Hope you are well.

Is there any chance you would be willing to send a letter of support to the Coastal Conservancy for authorization of funding to continue design of the restoration project? I don't know if Shelley contacted you, but it would be great to get community groups weighing in who support ecological restoration. Our meeting will be in LA, so I expect there will be some opposition.

Please let me know if you have any questions or need more info.

Thanks,

Mary

December 14, 2011

Mr. Doug Bosco, Chairman  
State Coastal Conservancy  
1330 Broadway, #1300  
Oakland, CA 94612  
Attn: Mary Small

RE: Proposed Conservancy Authorization for Ballona Wetlands Restoration Engineering and Technical Studies

Dear Chairman Bosco:

I am writing to encourage the Conservancy to authorize funding for the Ballona Wetlands Ecological Reserve Restoration Project planning process. These authorizations would enable the development of technical assessments and engineering design, technical review and agency coordination to support environmental impact analysis and permit applications for the restoration of the Ballona Wetlands Ecological Reserve (BWER).

The Ballona Wetlands Ecological Reserve is 600 acres, surrounded by urban Los Angeles County. The BWER provides valuable and scenic open space in the heart of congested Los Angeles County and offers one of the largest and most promising opportunities for coastal wetland restoration in the region. When restored and opened to the public, the site will allow millions of residents and visitors a rare opportunity to experience a coastal wetland. I support this project because it will help to move the restoration of the Ballona Wetlands Ecological Reserve closer to fruition. Thank you for your consideration of this project.

Sincerely,

**From:** [Mary Small](#)  
**To:** "[Shelley Luce](#)"  
**Subject:** RE: draft support letter for SCC board meeting  
**Date:** Tuesday, January 03, 2012 1:27:00 PM

---

Thanks!

I will talk to Sam about Boxer and Feinstein. Can LA Co DPW send a letter or do you think that is covered by the Supervisors?

Mary

---

**From:** Shelley Luce [mailto:[sluce@santamonicabay.org](mailto:sluce@santamonicabay.org)]  
**Sent:** Tuesday, January 03, 2012 1:25 PM  
**To:** Mary Small; Diana Hurlbert  
**Subject:** RE: draft support letter for SCC board meeting

Hi Mary,

We are working on:

Knabe

MRT

Friends of BW

So Cal Edison

So Cal Gas

LMU

Waxman

Lieu

Butler

Rosendahl

And Anyone else you want to add to that list. Figured Feinstein and Boxer will be more important later, and that you and Sam are the best ones to approach them.

*Shelley Luce, D.Env.  
Executive Director  
Santa Monica Bay Restoration Commission  
Pereira Annex MS:8160  
1 LMU Drive, Loyola Marymount University  
Los Angeles, CA 90045  
310-961-4444*

[www.santamonicabay.org](http://www.santamonicabay.org)

---

**From:** Mary Small [mailto:[msmall@scc.ca.gov](mailto:msmall@scc.ca.gov)]  
**Sent:** Tuesday, January 03, 2012 1:06 PM  
**To:** Shelley Luce; Diana Hurlbert  
**Subject:** FW: draft support letter for SCC board meeting

Hi

I belatedly just sent this request to DFG and SLC. The only support letter I have is from MRCA, though I know the port is working on one too. Can you let me know who you are working on

getting letters from and if there is anyone else I should follow-up with?

Thanks

Mary

---

**From:** Mary Small [mailto:msmall@scc.ca.gov]

**Sent:** Tuesday, January 03, 2012 1:04 PM

**To:** 'Griggs, Pamela@SLC'; 'Terri Stewart'; 'dlawhead@dfg.ca.gov'; 'Rick Mayfield (rmayfield@dfg.ca.gov)'

**Subject:** draft support letter for SCC board meeting

Hi

Sorry I didn't send this to you earlier, I meant to send it before the holidays, but forgot. I was wondering if your agencies would send a support letter to Coastal Conservancy for the requested authorization for funds for engineering and final design for Ballona. Our meeting will be in LA so I expect there will be some opposition and it is a huge funding request since we decided to do the EIR and permitting for the whole project.

If you could attend the site tour of Ballona and the meeting (both on Jan 19<sup>th</sup>) that would be great too.

Please let me know if you have any questions or need more info.

Thanks

Mary

*Pereira Annex MS:8160  
1 LMU Drive, Loyola Marymount University  
Los Angeles, CA 90045  
310-961-4444*

[www.santamonicabay.org](http://www.santamonicabay.org)

---

**From:** Knatz, Geraldine [mailto:knatz@portla.org]  
**Sent:** Sunday, December 11, 2011 1:00 PM  
**To:** Shelley Luce; Zordilla, Eunice  
**Cc:** Tankersley, Eileen  
**Subject:** Re: Letter for Coastal Conservancy Board

The letter was drafted the day after you asked me. Not sure what happened. Eunice- can you check.

Geraldine Knatz  
Executive Director  
Port of Los Angeles

---

**From:** Shelley Luce [mailto:sluce@santamonicabay.org]  
**Sent:** Friday, December 09, 2011 04:26 PM  
**To:** Knatz, Geraldine  
**Cc:** Tankersley, Eileen  
**Subject:** Letter for Coastal Conservancy Board

Dear Geraldine,

When we spoke a month or so ago, I asked if you would provide a letter to Sam Schuchat and his Board regarding your interest in the Ballona Wetlands restoration project. The January meeting of the Conservancy Board will be in Los Angeles and Sam will ask the Board to approve a large sum for continuing the planning and permitting of the restoration project, so your support of the project and interest in providing mitigation funding is important. Do you still intend to provide a letter and can I help with drafting? Also, we will give the Board members a tour of the wetland and briefing on the restoration plan before or after the Board meeting. As soon as we have a date I will send you an invitation and hope that you could come along.

Thank you Geraldine,  
Shelley

*Shelley Luce, D.Env.  
Executive Director  
Santa Monica Bay Restoration Commission  
Pereira Annex MS:8160  
1 LMU Drive, Loyola Marymount University  
Los Angeles, CA 90045  
310-961-4444*

[www.santamonicabay.org](http://www.santamonicabay.org)

-----Confidentiality Notice-----

This electronic message transmission contains information from the Port of Los Angeles, which may be confidential. If you are not the intended recipient, be aware that any disclosure, copying, distribution or use of the content of this information is prohibited. If you have received this communication in error, please notify us immediately by e-mail and delete the original message and any attachment without reading or saving in any manner.

Mark Gold, D.Env. | President

Heal the Bay | 1444 9th Street | Santa Monica CA 90401

Tel: 310 451 1500 X123 | Fax: 310 496 1902 | [mgold@healthebay.org](mailto:mgold@healthebay.org)

**DONATE NOW** to protect what you love: make an Aquadoption, shop at our online store or dedicate a Heal the Bay membership or donation.

PRIVILEGE AND CONFIDENTIALITY NOTICE

This message is intended only for the use of the individual or entity to which it is addressed and may contain information that is privileged, confidential and exempt from disclosure under applicable law as confidential communications. If the reader of this message is not the intended recipient, you are hereby notified that any dissemination, distribution, or copying of this communication or other use of a transmission received in error is strictly prohibited. If you have received this transmission in error, immediately notify us at 310-451-1500.

---

**From:** Mary Small [<mailto:msmall@scc.ca.gov>]  
**Sent:** Tuesday, January 03, 2012 2:16 PM  
**To:** Mark Gold  
**Subject:** support letter for SCC board meeting?

Hello Mark,

Happy New Year. I am emailing to see if Heal the Bay would be willing to send a letter of support to the Coastal Conservancy for the recommendation that we authorize \$6.5M for the design and engineering of the proposed restoration project? My draft staff report is attached along with a sample letter. I know you have talked to Shelley about the project, but I would be happy to give you an update at any time. Of course I understand if you are not prepared to take a position on this project at this point, but our meeting will be in Culver City, so I expect there will be some opposition.

Please let me know if you have any questions or need more info.

Thanks,

Mary

**From:** Shelley Luce  
**To:** Mary Small; Karina Johnston  
**Subject:** Fw: Coastal Conservancy funding to complete Ballona Wetlands restoration planning  
**Date:** Wednesday, January 18, 2012 10:13:14 PM  
**Attachments:** BCR\_Support\_for\_SCC\_Ballona\_Wetlands\_Funding\_Authorization.pdf

---

Jim Lank comes through! Karina or Elena can you please print a copy for me when you get in the office tomorrow? Thank you.

Shelley,

Emails have been flying today, with the end result that BCR is a strong supporter of the requested authorization. See the attached letter. Should we bring copies to give to the board and staff?

As I said before, both Bobbi Gold and I plan to be at the Scenic Overlook for the 1pm meeting start. Bobbi plans to be there for the whole discussion of the agenda item, while I'll stay as long as I can. Both of us plan to sign in to speak on the item. As part of that, I assume it would be appropriate to read the letter, at least in part. If not, let me know.

I hope the tour and meeting both go well. FYI, I'll be leaving soon for another meeting.

Thanks again for your quick response with the helpful cost information.

Jim

*Jim Lamm, President*

**Ballona Creek Renaissance (BCR)...Connecting Creek and Community from the Hills to the Bay**  
310-839-6896, 310-367-0336 (c), <http://facebook.com/ballonacreekrenaissance>, [www.ballonacreek.org](http://www.ballonacreek.org)

---

**From:** Shelley Luce <sluce@santamonicabay.org>  
**To:** Jim Lamm <jim.lamm@sbcglobal.net>  
**Sent:** Wed, January 11, 2012 11:19:55 AM  
**Subject:** RE: [REPLY] Fw: Coastal Conservancy funding to complete Ballona Wetlands restoration planning

Thank you very much Jim! I hope you had a nice holiday too. It's going to be a great 2012.

Shelley

*Shelley Luce, D.Env.*

*Executive Director*

*Santa Monica Bay Restoration Commission*

*Pereira Annex MS:8160*

*1 LMU Drive, Loyola Marymount University*

*Los Angeles, CA 90045*

*310-961-4444*

[www.santamonicabay.org](http://www.santamonicabay.org)

---

**From:** Jim Lamm [mailto:jim.lamm@sbcglobal.net]  
**Sent:** Wednesday, January 11, 2012 10:58 AM  
**To:** Shelley Luce



**Subject:** Re: [REPLY] Fw: Coastal Conservancy funding to complete Ballona Wetlands restoration planning

Shelley,

Please accept my apologies for this late response. Cathi and I were away on a 2 1/2 week driving trip to the Seattle area for a holiday visit with our kids and grandkids. Then after returning late last Thursday, we've been focused on moving Cathi's 93-year-old mom in with us. I'm just now beginning to turn more of my attention to a backlog of BCR and other matters.

Unfortunately I have an important 3pm meeting at Culver City Hall on the afternoon of the 1pm SCC board meeting at the Scenic Overlook. If I were able to speak on the restoration planning agenda item before about 2:40pm, it could work. Otherwise (or in addition) I might be able to get Bobbi Gold or another knowledgeable BCR board member to represent us.

As for a BCR support letter, I'm pretty sure that would not be a problem. This is on my list of things to bounce off the board prior to our next board meeting.

Here's to a great new year, despite the challenges ahead!

Jim

*Jim Lamm, President*

*Ballona Creek Renaissance (BCR)...Connecting Creek and Community from the Hills to the Bay  
310-839-6896, 310-367-0336 (c), <http://facebook.com/ballonacreekrenaissance>, [www.ballonacreek.org](http://www.ballonacreek.org)*

---

**From:** Shelley Luce <[sluce@santamonicabay.org](mailto:sluce@santamonicabay.org)>

**To:** Jim Lamm <[jim.lamm@sbcglobal.net](mailto:jim.lamm@sbcglobal.net)>

**Sent:** Fri, January 6, 2012 5:32:52 PM

**Subject:** Coastal Conservancy funding to complete Ballona Wetlands restoration planning

Hello Jim,

I hope you had a lovely Christmas and a happy new year! I did enjoy a nice break.

You may have heard that the Board of the Coastal Conservancy will meet in LA on Jan. 19 and will consider a request from their staff to authorize funding to complete the Ballona Wetlands restoration planning. The request is for about \$6.3M and most will go to consultants for additional engineering (through final design), to create a public access master plan, and to do extensive hydraulic modeling as required by Army Corp permitting (the major expense). About \$240k will come to SMBRF to fund Diana's position as well as monitoring on the site for the next three years. I don't know if there will be active opposition to this but I am preparing for that nonetheless. Also I see this as a good opportunity to let the SCC board members see the great support that exists in our community for restoration at Ballona.

Please let me know if you are able to support by letter or by attending the meeting. It was posted today on SCC website <http://scc.ca.gov/2012/01/06/coastal-conservancy-public-meeting-january-19-2012/>

I am attaching the staff report for the item and a couple of example support letters as well. Thank you Jim!

shelley

*Shelley Luce, D.Env.*

*Executive Director*

*Santa Monica Bay Restoration Commission*

*Pereira Annex MS:8160*

**Subject:** Re: Letter for Coastal Conservancy Board

The letter was drafted the day after you asked me. Not sure what happened. Eunice- can you check.

Geraldine Knatz  
Executive Director  
Port of Los Angeles

---

**From:** Shelley Luce [mailto:sluce@santamonicabay.org]  
**Sent:** Friday, December 09, 2011 04:26 PM  
**To:** Knatz, Geraldine  
**Cc:** Tankersley, Eileen  
**Subject:** Letter for Coastal Conservancy Board

Dear Geraldine,

When we spoke a month or so ago, I asked if you would provide a letter to Sam Schuchat and his Board regarding your interest in the Ballona Wetlands restoration project. The January meeting of the Conservancy Board will be in Los Angeles and Sam will ask the Board to approve a large sum for continuing the planning and permitting of the restoration project, so your support of the project and interest in providing mitigation funding is important. Do you still intend to provide a letter and can I help with drafting? Also, we will give the Board members a tour of the wetland and briefing on the restoration plan before or after the Board meeting. As soon as we have a date I will send you an invitation and hope that you could come along.

Thank you Geraldine,  
Shelley

*Shelley Luce, D.Env.  
Executive Director  
Santa Monica Bay Restoration Commission  
Pereira Annex MS:8160  
1 LMU Drive, Loyola Marymount University  
Los Angeles, CA 90045  
310-961-4444*

[www.santamonicabay.org](http://www.santamonicabay.org)

---

-----Confidentiality Notice-----  
This electronic message transmission contains information from the Port of Los Angeles, which may be confidential. If you are not the intended recipient, be aware that any disclosure, copying, distribution or use of the content of this information is prohibited. If you have received this communication in error, please notify us immediately by e-mail and delete the original message and any attachment without reading or saving in any manner.

**From:** Mary Small  
**To:** "Shelley Luce"; "Diana Hurlbert"  
**Subject:** FW: draft support letter for SCC board meeting  
**Date:** Tuesday, January 03, 2012 1:05:00 PM  
**Attachments:** SCC Ballona Tech Support Ltr.docx

---

Hi

I belatedly just sent this request to DFG and SLC. The only support letter I have is from MRCA, though I know the port is working on one too. Can you let me know who you are working on getting letters from and if there is anyone else I should follow-up with?

Thanks

Mary

---

**From:** Mary Small [mailto:msmall@scc.ca.gov]  
**Sent:** Tuesday, January 03, 2012 1:04 PM  
**To:** 'Griggs, Pamela@SLC'; 'Terri Stewart'; 'dlawhead@dfg.ca.gov'; 'Rick Mayfield (rmayfield@dfg.ca.gov)'  
**Subject:** draft support letter for SCC board meeting

Hi

Sorry I didn't send this to you earlier, I meant to send it before the holidays, but forgot. I was wondering if your agencies would send a support letter to Coastal Conservancy for the requested authorization for funds for engineering and final design for Ballona. Our meeting will be in LA so I expect there will be some opposition and it is a huge funding request since we decided to do the EIR and permitting for the whole project.

If you could attend the site tour of Ballona and the meeting (both on Jan 19<sup>th</sup>) that would be great too.

Please let me know if you have any questions or need more info.

Thanks

Mary

*1 LMU Drive, Loyola Marymount University  
Los Angeles, CA 90045  
310-216-9827  
[www.santamonicabay.org](http://www.santamonicabay.org)*

---

**From:** Jim Lamm [jim.lamm@sbcglobal.net]  
**Sent:** Monday, November 14, 2011 8:51 PM  
**To:** Jessica Hall  
**Cc:** Diana Hurlbert; Shelley Luce  
**Subject:** Re: Request for Support Letters - Urban Greening - Cochran Avenue

Jessica,

BCR's letter of support is attached. Here's to a successful project!  
Jim

*Jim Lamm, President  
Ballona Creek Renaissance (BCR)...Connecting Creek and Community from the Hills to the Bay  
310-839-6896, 310-367-0336 (c), <http://facebook.com/ballonacreekrenaissance>, [www.ballonacreek.org](http://www.ballonacreek.org)*

---

**From:** Jessica Hall <jishica@mac.com>  
**To:** Jim Lamm <jim.lamm@ballonacreek.org>; diana hurlbert <dhurlbert@santamonicabay.org>  
**Cc:** shelly <sluce@santamonicabay.org>  
**Sent:** Mon, November 14, 2011 10:44:14 AM  
**Subject:** Request for Support Letters - Urban Greening - Cochran Avenue

Hi Jim and Diana,  
I am working on the urban greening grant for SMBRF for Cochran Avenue Gateway project. Jim, I was wondering if BCR would write a letter of support, and Diana, I was wondering if there were other stakeholders in the Ballona community that you have contact info for, that would also provide a letter of support. Any technical experts would be especially appreciated. A draft letter is enclosed.

The grant is due Thursday.

Thanks!  
Jessica

**From:** [Mary Small](#)  
**To:** "Mark Gold"  
**Cc:** [stuce@santamonicaabay.org](mailto:stuce@santamonicaabay.org)  
**Subject:** RE: support letter for SCC board meeting?  
**Date:** Friday, January 06, 2012 4:23:00 PM

---

I was just talking to Shelley and we were wondering if you could send a staff person to the meeting even if you don't want to sign a letter? Maybe Meredith or someone on her staff could come to talk about the need to open the site to public access and restore nature in the city?

This authorization doesn't commit to any one project, we still will be going through CEQA and NEPA.

Thanks  
Mary

---

**From:** Mary Small [<mailto:msmall@scc.ca.gov>]  
**Sent:** Tuesday, January 03, 2012 3:00 PM  
**To:** 'Mark Gold'  
**Subject:** RE: support letter for SCC board meeting?

Thanks, the meeting is the 19<sup>th</sup> so that's the deadline. Yes, I totally understand.

I was just sending Sarah an email about possible dates I'll be in LA when I'd like to stop in and talk about OPC, so maybe I'll see you then.

Happy new year (and MLPA implementation)  
Mary

---

**From:** Mark Gold [<mailto:mgold@healthebay.org>]  
**Sent:** Tuesday, January 03, 2012 2:39 PM  
**To:** Mary Small  
**Subject:** RE: support letter for SCC board meeting?

Mary – Happy new year to you too. We will definitely take a look at this and think it through. It is a great project and needs to happen. The political baggage that goes with it is no picnic as you know.

When is the deadline?

Mark Gold, D.Env. | President  
Heal the Bay | 1444 9th Street | Santa Monica CA 90401  
Tel: 310 451 1500 X123 | Fax: 310 496 1902 | [mgold@healthebay.org](mailto:mgold@healthebay.org)  
**DONATE NOW** to protect what you love: make an [Aquadoption](#), shop at our [online store](#) or dedicate a Heal the Bay [membership](#) or [donation](#).

PRIVILEGE AND CONFIDENTIALITY NOTICE

This message is intended only for the use of the individual or entity to which it is addressed and may contain information that is privileged, confidential and exempt from disclosure under applicable law as confidential communications. If the

reader of this message is not the intended recipient, you are hereby notified that any dissemination, distribution, or copying of this communication or other use of a transmission received in error is strictly prohibited. If you have received this transmission in error, immediately notify us at 310-451-1500.

---

**From:** Mary Small [mailto:msmall@scc.ca.gov]  
**Sent:** Tuesday, January 03, 2012 2:16 PM  
**To:** Mark Gold  
**Subject:** support letter for SCC board meeting?

Hello Mark,

Happy New Year. I am emailing to see if Heal the Bay would be willing to send a letter of support to the Coastal Conservancy for the recommendation that we authorize \$6.5M for the design and engineering of the proposed restoration project? My draft staff report is attached along with a sample letter. I know you have talked to Shelley about the project, but I would be happy to give you an update at any time. Of course I understand if you are not prepared to take a position on this project at this point, but our meeting will be in Culver City, so I expect there will be some opposition.

Please let me know if you have any questions or need more info.

Thanks,

Mary

**From:** Mary Small  
**To:** "Dick Wayman"  
**Subject:** FW: Ballona Wetlands presentation materials at SCC meeting  
**Date:** Friday, January 20, 2012 4:03:00 PM

---

**From:** Shelley Luce [mailto:sluce@santamonicabay.org]  
**Sent:** Friday, January 20, 2012 3:12 PM  
**To:** Mary Small; Karina Johnston; Diana Hurlbert  
**Subject:** RE: Ballona Wetlands presentation materials at SCC meeting

Yes Mary - Karina or Diana can you please?  
Also wanted to make sure you saw/heard the NPR coverage:  
<http://www.scoptopnews.com/2012/01/20/30859/coastal-conservancy-approves-6-5-million-for-ballona-wet/>

The MDR patch did a pretty good job covering - except Lisa F's comments which are confusing to me, but I will call her about it - and LATimes is going to run something this weekend, I am told. Fingers crossed.  
<http://venice.patch.com/articles/coastal-conservancy-approves-6-5-million-for-ballona-wetlands-restoration-plans>

Thank you Diana and Karina for helping get this press coverage - the advance work we did made a HUGE difference! Please stay on top of me in the future to make sure we have the same success next time. great job.  
shelley

*Shelley Luce, D.Env.  
Executive Director  
Santa Monica Bay Restoration Commission  
Pereira Annex MS:8160  
1 LMU Drive, Loyola Marymount University  
Los Angeles, CA 90045  
310-216-9827  
[www.santamonicabay.org](http://www.santamonicabay.org)*

---

**From:** Mary Small [msmall@scc.ca.gov]  
**Sent:** Friday, January 20, 2012 2:52 PM  
**To:** Karina Johnston; Diana Hurlbert  
**Cc:** Shelley Luce  
**Subject:** Fwd: Ballona Wetlands presentation materials at SCC meeting

Could one of you email this to him?  
Thanks

sent from my phone

Begin forwarded message:

**From:** Rex Frankel <rexfrankel@yahoo.com>  
**Date:** January 20, 2012 12:46:45 PST  
**To:** Mary Small <msmall@scc.ca.gov>  
**Subject:** Re: Ballona Wetlands presentation materials at SCC meeting  
**Reply-To:** Rex Frankel <rexfrankel@yahoo.com>

Mary,  
thank you for the presentation materials. However, on the Baseline monitoring report page,  
<http://santamonicabay.org/smbay/ProgramsProjects/HabitatRestorationProject/BaselineAssessmentReport/tabid/203/Default.aspx>

the Chapter 4--Vegetation report does not come up when you click on it. I assume this is where Dr. Luce's conclusion comes from.

If you can, please email that chapter to me.

Thank you, Rex Frankel

---

**From:** Mary Small <msmall@scc.ca.gov>  
**To:** 'Rex Frankel' <rexfrankel@yahoo.com>  
**Sent:** Friday, January 20, 2012 12:09 PM  
**Subject:** RE: Ballona Wetlands presentation materials at SCC meeting

Hello Rex  
Attached is our slide presentation.

Yes, Dr. Luce was referring to the findings of the baseline assessment. I just went to the project website and clicked on the image of the report cover and was able to download the documents, but if there are specific chapters that you are unable to download, please let us know and we'll get them to you.

Mary

---

**From:** Rex Frankel [mailto:rexfrankel@yahoo.com]

**Sent:** Friday, January 20, 2012 10:13 AM  
**To:** [msmall@scc.ca.gov](mailto:msmall@scc.ca.gov)  
**Subject:** Ballona Wetlands presentation materials at SCC meeting

Mary,

I am interested in getting a copy of your slide presentation from yesterday's SCC Board meeting. Can you email it to me?

I am also interested in seeing the source documents that were used to make Dr. Luce's point that very little of the site is now functioning habitat.

Are they in the recently released SMBRC's Ballona Wetlands Baseline Assessment Program reports? The SMBRC has a website, [ballonarestoration.org](http://ballonarestoration.org), with the Baseline Assessment Program report, unfortunately, most of these documents do not open when clicked upon. They are posted here:  
<http://santamonicabay.org/smbay/ProgramsProjects/HabitatRestorationProject/BaselineAssessmentReport/tabid/203/Default.aspx>

Please call me or email if you can help.

Thanks, Rex Frankel, 310-738-0861



**From:** Mary Small  
**To:** "Joe Geever"  
**Cc:** "Shelley Luce"; "Diana Hurlbert"  
**Subject:** Coastal Conservancy Jan 19th Meeting  
**Date:** Thursday, December 15, 2011 11:25:00 AM  
**Attachments:** Ballona Wetlands Engineering and Technical Studies.docx

---

Hi Joe

Nice to talk to you this morning, and thanks for agreeing to come to the Coastal Conservancy meeting in Jan. It will be on Jan 19<sup>th</sup> at the Baldwin Hills Scenic Overlook starting around noon. Ballona funding (draft staff report attached) will be the first major item on the agenda. We are planning to take the Board on a tour of Ballona that morning. The tour and meeting are open to the public and details will be posted on our website by the 6<sup>th</sup> of Jan.

As I mentioned, we (Shelley and I) would be happy to provide additional information to you &/or your chapters at any point. Since we are finally getting ready to initiate the public environmental review, now would be a good time to get you engaged.

Thanks,  
Mary

~~~~~  
Mary Small  
Deputy Executive Officer, Coastal Conservancy  
1330 Broadway #1300 Oakland, CA 94612  
510-286-4181

**ATTACHMENT 4**

**From:** Mary Small  
**To:** "Shelley Luce"  
**Cc:** "Joan Cardellino (Joan Cardellino)"; "Diana Hurlbert"  
**Subject:** RE: Letter for Coastal Conservancy Board  
**Date:** Tuesday, December 13, 2011 1:11:00 PM

---

Thanks

Sorry, the plan is to have the tour from roughly 9-11:30 and then start the meeting at noon or 12:30 – something like that. We're afraid that if we do the tour after the meeting none of the board members will come.

I'll call Barbara today to get her ideas and see if they will help with the tour, come to the mtg or send a letter

Mary

---

**From:** Shelley Luce [mailto:sluce@santamonibay.org]  
**Sent:** Tuesday, December 13, 2011 1:08 PM  
**To:** Mary Small  
**Cc:** 'Joan Cardellino (Joan Cardellino)'; Diana Hurlbert  
**Subject:** RE: Letter for Coastal Conservancy Board

Mary, here are some thoughts from me and Diana:

- 1) Tour – we'll do the tour anytime that works for your members but it seems tight to finish it by 9:15 in order to get them all to Baldwin Hills Overlook for a 10 am meeting. I know we have the Toy meeting the day before so right after the board meeting makes most sense. Could you convince your members to stick around for it?
- 2) Press – this is troubling. It'll be hard for us to get good press on a \$7M expenditure... we can spin this if we get the right people. What if we did a brief presentation on the Monitoring Report before hand? We'll have beautiful hard copies, it's over 400 pages and very impressive and did not cost a lot for the amount of work and info. I think it makes SCC and SMBRC look great. Could we make this the press focus, i.e. with Molly Peterson at least? I'll give her a call for starters.
- 3) Support – I will talk with Geever, Jim Lamm, Miguel, Lisa Fimiana, Baykeeper, HTB, Nate from Rosendahl's office, Napolitano from Knabe's and Karly from MRT's. I can't say who will show up or do a letter but I will make the asks. I'll also ask Pestrella. Can you talk to MRCA Mary? Also what about the Corps – Rick Liefeld's support would be very meaningful, or Toy's if we can get it. Maybe a letter from Toy with Rick or someone else attending the meeting?

We'll draft a support letter asap and run it by you.

Shelley

*Shelley Luce, D.Env.  
Executive Director  
Santa Monica Bay Restoration Commission  
Pereira Annex MS:8160*

1 LMU Drive, Loyola Marymount University  
Los Angeles, CA 90045  
310-961-4444

[www.santamonicabay.org](http://www.santamonicabay.org)

---

**From:** Mary Small [mailto:msmall@scc.ca.gov]  
**Sent:** Tuesday, December 13, 2011 10:38 AM  
**To:** Shelley Luce  
**Cc:** 'Joan Cardellino (Joan Cardellino)'  
**Subject:** RE: Letter for Coastal Conservancy Board

Hi Shelley-

Do you have time to talk about our Jan meeting? I know you have a board meeting this week, so we could also do this via email – or next week, but before next Fri I'd like to work through some ideas:

- 1) Tour – we'll probably do a tour the morning of the meeting, I think maybe the tour we did with Colonel Toy – view from Cabora Rd and then walk out to boyscout platform
- 2) Press – do you think we could use this meeting as an opportunity to get either local papers and/or try for LA Times to cover the project? I am worried that once the agenda is out Marcia will use as opportunity to get bad press. Our agenda will be mailed out Jan 6<sup>th</sup>
- 3) Public support – who could we have come to support the project at the meeting or with letters? Geraldine is critical (at least her letter) but how about MRCA?, Joe Geever?, Ballona Creek Renaissance?, Friends?, Miguel Luna?, Audubon? HtB? Baykeeper?

Thanks,  
Mary

---

**From:** Shelley Luce [mailto:sluce@santamonicabay.org]  
**Sent:** Monday, December 12, 2011 3:22 PM  
**To:** Mary Small  
**Subject:** FW: Letter for Coastal Conservancy Board

Hi Mary, Geraldine thought her letter went out already. Have you received? I also invited her to tour the wetlands with us after the meeting.

*Shelley Luce, D.Env.  
Executive Director  
Santa Monica Bay Restoration Commission  
Pereira Annex MS:8160  
1 LMU Drive, Loyola Marymount University  
Los Angeles, CA 90045  
310-961-4444*

[www.santamonicabay.org](http://www.santamonicabay.org)

---

**From:** Knatz, Geraldine [mailto:knatz@portla.org]  
**Sent:** Sunday, December 11, 2011 1:00 PM  
**To:** Shelley Luce; Zordilla, Eunice  
**Cc:** Tankersley, Eileen

**From:** [Shelley Luce](#)  
**To:** [Mary Small](#)  
**Subject:** RE: board presentation  
**Date:** Wednesday, January 11, 2012 6:55:23 PM

---

Hi Mary,

I think the presentation looks good. I think we should include some comparative data to show the need for restoration – e.g. the seed bank data, the exotic veg data and some of the animal data (birds and herps). I saw what karina sent you and it doesn't help us – we need numbers like “99% invasive plants” and “lowest seed bank of any so cal wetland”. we also need her graphs that show huge percent exotic veg. versus tiny percent native veg, etc. along with those photos of invasive plants that you already included.

I also think we should mention the TMDL –or not the TMDL itself, but we can list the impairments listed on the 303d list, note that TMDL implementation would be consistent with the restoration and that we can work with partners on my governing board and other agencies and leverage resources that would go into implementing the TMDL.

I can help with slides – why don't you send me one or two in your formatting and I will make some with the graphs imentioned and see if you like them. Or rather, since you have to finish by tomorrow and I am out of the office all day, we will ask karina to insert some graphs. Okay with you?

Shelley

*Shelley Luce, D.Env.  
Executive Director  
Santa Monica Bay Restoration Commission  
Pereira Annex MS:8160  
1 LMU Drive, Loyola Marymount University  
Los Angeles, CA 90045  
310-961-4444*

[www.santamonicabay.org](http://www.santamonicabay.org)

---

**From:** Mary Small [mailto:msmall@scc.ca.gov]  
**Sent:** Wednesday, January 11, 2012 2:49 PM  
**To:** Shelley Luce  
**Subject:**

Hi Shelley

Attached is a draft powerpoint, I want to keep it as simple as we can. There are several extra slides at the end, I just want one picture I can leave up when I walk through the actual requested action, maybe just the bird with its head in the water?

There are two slides about the baseline monitoring program – I think we only need one of them, do you prefer lots of words or just a picture.

I am sending in .pdf because the actual powerpoint is too big. If you want me to ftp the powerpoint so you can edit directly, let me know. I have to finish this by tomorrow night.

Thanks!  
Mary

**From:** [Shelley Luce](#)  
**To:** [Karina Johnston](#)  
**Cc:** [msmall@scc.ca.gov](mailto:msmall@scc.ca.gov)  
**Subject:** graphs needed for SCC board presentaiton  
**Date:** Thursday, January 12, 2012 7:57:56 AM

---

Hi Karina,

Thank you for the bullets you prepped for Mary, they are helpful. The photos are also perfect. What we still need for the presentation are graphics or numbers that will really make our case. Mary needs to complete the presentation today so can you and your team help us prep the following ASAP?

- one map of existing conditions that shows the site today. an aerial photo with transparent overlay of BASIC habitat types - how much is wetland, how much is upland/vacant lot style. goal is to illustrate how little of the site can be said to be functioning habitat.
- one simple graph showing predominance of invasive species - the one in the BWER draft TMDL is fine, can you please send that to mary? we need to say "x percent of the site is covered with 99% invasive vegetation" or whatever the actual numbers are. rather than "dominate by invasives" which could mean only 55% covered.
- some species diversity numbers/charts that show how extremely depauperate poor Ballona is. not just "reduced relative to other wetlands" but "lowest seed bank abundance and diversity of any wetland in southern california" - but i need you to give me the right language so i am not mis-stating anything. please give me those #s or charts or language for seed bank, veg, mammals, birds, fish and herps separately and we'll decide which ones to mention in our presentation.
- any other features of the site or results from your surveys that really illustrate to non-scientists how desperate is the need to restore ecological function and habitat at the site.

I am sorry to ask you for all this today, I hope you or one of your team has time. I think you have all this info readily accessible - f there is something i've requested that is a big pain check with me and we'll decide if it's really needed. please call my cell or email, i will be out of the office all day but checking my phone compulsively. also please suggest other stuff if you think of it - you know these data better than we do! thank you KJ talk to you later today.  
shelley

*Shelley Luce, D.Env.  
Executive Director  
Santa Monica Bay Restoration Commission  
Pereira Annex MS:8160  
1 LMU Drive, Loyola Marymount University  
Los Angeles, CA 90045  
310-216-9827  
[www.santamonicabay.org](http://www.santamonicabay.org)*

**From:** [Mary Small](#)  
**To:** "[Karina Johnston](#)"; "[Diana Hurlbert](#)"; "[Shelley Luce](#)"  
**Subject:** please review these two paragraphs  
**Date:** Tuesday, December 13, 2011 9:09:00 AM

---

Hi

I'm wrapping up my staff report and I needed to add a little more detail about what SMBRF will do with the grant funds and who you are. Can you please review this and let me know if you have any edits? If you can get it to me today, that'd be great.

Mary

The recommended grant to the SMBRF would provide funds for data collection, technical review and agency coordination to support the proposed restoration project. The SMBRF has implemented a multidisciplinary baseline data collection program using volunteers, students and professional technical experts. The baseline report is the first comprehensive assessment of biological and physical resources at the BWER. It was just published and is available online: <http://www.ballonarestoration.org>. This grant would allow the SMBRF to conduct additional targeted studies based on the resources identified in the baseline assessment as needed to support the environmental impact analysis of the proposed project. In addition, the SMBRF will continue coordination of the agency review, identification of funding partners, and technical review of work products associated with this project.

The SMBRF is a non-profit organization that was created in 1991 to implement the priorities of the Santa Monica Bay Restoration Plan and to support the work of the Santa Monica Bay Restoration Commission. The SMBRF has a number of initiatives including research, public education, and planning, to support these goals. The SMBRF and the Seaver College of Science and Engineering at Loyola Marymount University (LMU) created the Center for Santa Monica Bay Studies to engage in multidisciplinary research on environmental and social issues affecting Santa Monica Bay and its watershed, and to contribute to policies and actions that improve the environmental condition of the Bay. The partnership with LMU has been very valuable to the data collection efforts, SMBRF has used student volunteers to conduct fieldwork and some faculty have coordinated their own research to support the baseline assessment, resulting in hundreds of hours of field work being donated to the project.

~~~~~  
Mary Small  
Deputy Executive Officer, Coastal Conservancy  
1330 Broadway #1300 Oakland, CA 94612  
510-286-4181



**ATTACHMENT 5**

NORMAN Y. MINETA, Chairman

AND SHUSTER, Representatives  
Committee on Public Works and Transportation

JAMES L. OBERSTAR, Chairman  
 WEAVER L. COOPER, Vice Chairman  
 DOUGLAS AMBRICATE, Chairman  
 RON W. LUCCO, Vice Chairman  
 ROBERT A. BISHOP, Representative  
 TIM VALENZUELA, Representative  
 WILLIAM G. (GIBBY) BROWN, Representative  
 ROBERT I. WELLS, Jr., Representative  
 JAMES A. TRAVIS, Jr., Representative  
 PETER A. BRADLEY, Representative  
 JIMMY HAYES, Representative  
 BOB CLIMENT, Representative  
 JERRY J. BOYLLIVILLE, Representative  
 MARK FRANKER, Representative  
 JAMES LAURENCE, Representative  
 PATTY CHERN, Representative  
 GEORGE E. SANDERSON, Representative  
 CLARENCE ROSENBERG, Representative  
 BOB BAKER, Representative  
 KAREN HANCOCK, Representative  
 ELEANOR HOLMES NORTON, Representative  
 LUCIAN S. BLACKWELL, Representative

JEROME R. RYAN, Representative  
 JAMES C. COOPER, Representative  
 LESLIE L. STONE, Representative  
 MARIA CASTRO, Representative  
 PAT HASTY, Representative  
 KAREN HANCOCK, Representative  
 ROBERT HENNING, Representative  
 JAMES E. CLYBURN, Representative  
 CUYLER R. SHAW, Representative  
 NATHAN S. BLUM, Representative  
 JAMES A. BARNES, Representative  
 DAN HANSEN, Representative  
 BOB FLYNN, Representative  
 WALTER A. TURNER, Representative  
 EDGAR RENNIE, Representative  
 PETER W. BARNES, Representative

PAUL SCHUMAKER, Chief of Staff  
SARIE SIMPSON, Staff Counselor

# U.S. House of Representatives COMMITTEE ON PUBLIC WORKS AND TRANSPORTATION

SUITE 2186 RAYBURN HOUSE OFFICE BUILDING  
WASHINGTON, DC 20518  
(202) 225-4472

WALTER A. CLINGER, Jr., Representative  
 THOMAS I. PETE, Representative  
 JEROME RYAN, Representative  
 JAMES H. BROWN, Representative  
 BILL BRADLEY, Representative  
 JOHN J. DUNCAN, Jr., Representative  
 SUSAN MALINAK, Representative  
 WILLIAM M. KELLY, Jr., Representative  
 TOM SWINEY, Representative  
 WARREN T. CHRISTENSEN, Representative  
 ROBERT BURN, Representative  
 TIM WATSON, Representative  
 BILL BAILEY, Representative  
 BOB COLLINS, Representative  
 JAY C. SIMS, Representative  
 DAVID A. LEVY, Representative  
 STEVE WOOD, Representative  
 BOB FRANKS, Representative  
 PETER J. BLUTE, Representative  
 HOWARD P. BUCK, Representative  
 JOHN L. MICA, Representative  
 PETER ROBERTS, Representative  
 JACK QUINN, Representative  
 MERRICK L. HILL, Representative

## COMMITTEE ON PUBLIC WORKS AND TRANSPORTATION U.S. HOUSE OF REPRESENTATIVES WASHINGTON, D.C.

### RESOLUTION

Marina del Rey, California  
Docket 2455

Resolved by the Committee on Public Works and Transportation of the United States House of Representatives, That the Secretary of the Army is requested to review the report of the Chief of Engineers on Playa del Rey Inlet and Basin, Venice, California, published as House Document 389, Eighty-third Congress, Second Session, and other pertinent reports, to determine whether modifications of the recommendations contained therein are advisable at the present time, in the interest of navigation, hurricane and storm damage reduction, environmental restoration, and other purposes at Marina del Rey Harbor, Los Angeles, California, with consideration given to the disposal of contaminated sediments from the entrance channel required under the existing operation and maintenance program at Marina del Rey Harbor.

Adopted: September 23, 1994

ATTEST:   
 NORMAN Y. MINETA, Chair

P. 3/6

OCT 13 1994 09:43AM CORPS OF ENGRS CECP-R

-----  
DEPARTMENT OF DEFENSE Department of the Army; Corps of Engineers  
Notice of Intent To Prepare an Environmental Impact Statement/  
Environmental Impact Report for the Ballona Creek Ecosystem Restoration  
Feasibility Study, Los Angeles County, CA AGENCY: Department of the  
Army, U.S. Army Corps of Engineers, DoD. ACTION: Notice of intent. --  
-----

SUMMARY: The Los Angeles District intends to prepare an Environmental  
Impact Statement/Environmental Impact Report (EIS/EIR) to support a  
cost-shared ecosystem restoration feasibility study with the Santa  
Monica Bay Restoration Commission. The proposed project study areas has  
been degraded by encroachment of non-native plants, placement of fill  
from Marina Del Rey, interruption of the hydrologic regime, trash  
accumulation, and varied attempts at bank protection along the creek  
using rock and concrete. Direct benefits of the proposed project  
include improved habitat and water quality, reductions in waste and  
trash, and aesthetics. The watershed is an important resource for both  
recreational uses and for fish, and wildlife and further degradation  
could jeopardize remaining. The purpose of the feasibility study is to  
evaluate alternatives for channel modification, habitat restoration  
(coastal and freshwater wetlands and riparian), recreation, and related  
purposes along the lower reach of the Ballona Creek. DATES: A public  
scoping meeting will be held on September 29, 2005 at 6 p.m.

ADDRESSES: U.S. Army Corps of Engineers, Los Angeles District, CESPL-  
PD, P.O. Box 532711, Los Angeles, CA 90053 and Santa Monica Bay  
Restoration Commission, 320 West 4th Street, Los Angeles, CA 90013.

FOR FURTHER INFORMATION CONTACT: Shannon Dellaquila, Project  
Environmental Manager, at (213) 452-3850 or Malisa Martin, Project  
Study Manager at (213) 452-3828. SUPPLEMENTARY INFORMATION: 1.

Authorization This study was prepared as an interim response to  
the following authorities provided by Congress under Section 216 of  
the Flood Control Act of 1970, which states: The Secretary of the  
Army, acting through the Chief of Engineers, is authorized to review  
the operation of projects the construction of which has been completed  
and which were constructed by the Corps of Engineers in the interest  
of navigation, flood control, water supply, and related purposes, when  
found advisable due the significantly changed physical or economic  
conditions, and to report thereon to Congress with recommendations on  
the advisability of modifying the structures or their operation, and  
for improving the quality of the environment in the overall public  
interest; supplemented by House Resolution on Public Works and  
Transportation dated September 28, 1994 which states: The  
Secretary of the Army is requested to review the report of the Chief  
of Engineers on Playa del Rey Inlet and Basin, Venice, California,  
published as House Document 389, Eighty-third Congress, Second  
Session, and other pertinent reports, to determine whether  
modifications of the recommendations contained therein are advisable  
at present time, in the interest of navigation, hurricane and storm  
damage reduction, environmental restoration, and other purposes at  
Marina del Rey Harbor, Los Angeles, California, with consideration  
given to disposal of contaminated sediments from the entrance channel  
required under the existing operation and maintenance program at  
Marina del Rey. 2. Background The Ballona Creek Ecosystem

Restoration study area lies within Los Angeles County, CA and includes portions of Marina del Rey, Culver City, Playa del Rey, and the City of Los Angeles. The study area, a component of the greater Ballona Creek Watershed, includes the lower reach of Ballona Creek extending southwest from Cochran Avenue, in Los Angeles, to Pacific Ocean in Marina del Rey. specific features of the Ballona Creek watershed, including existing and historic wetland areas, the Ballona Lagoon, Del Rey Lagoon, Venice Canal, Grand Canal, the Oxford Drain and the Ballona Channel and tributaries, will be addressed in this study. The greater Ballona Creek system drains a watershed of approximately 329 square kilometers (81,300 acres), and is the largest tributary that drains into the Santa Monica Bay. Ballona Creek collects runoff from several partially urbanized canyons on the south slopes of the Santa Monica Mountains as well as from intensely urbanized areas of West Los Angeles, Culver City, Beverly Hills, Hollywood, and parts of Central Los Angeles. The urbanized areas account for 80 percent of the watershed area, and the partially developed foothills and mountains make up the remaining 20 percent. The watershed boundary includes the Santa Monica Mountains on the north, the unincorporated area known as Baldwin Hills, and the City of Inglewood on the south. The Ballona Creek Ecosystem Restoration study footprint's southern boundary is defined by the Westcheste Bluffs, which run southwest from the San Diego (405) Freeway beyond Loyola Marymount University. The western boundary extends from the Pacific Ocean. The eastern boundary begins where Ballona Creek daylight at Cochran Avenue and Venice Boulevard in a section of Los Angeles known as the Mid City. Tributaries of Ballona Creek include Centinela Creek, Sepulveda Canyon Channel, Benedict Canyon Channel, and numerous storm drains. The Ballona Creek watershed ecosystem has been altered by intense land development, encroachment of non-native plants, trash accumulation, and varied attempts at bank protection along the creek using rock and concrete. Although an important function of the Ballona Creek is as a flood control channel, the lower watershed is still an important resource for both recreational uses and for fish and wildlife habitat. Further impairment could jeopardize remaining habitat. This study will evaluate opportunities for habitat restoration (including wetland and riparian habitat), improvements to water quality, trash mitigation, and recreation and related purposes along the lower reach of the Ballona creek.

3. Problems and Needs At least ninety (90) percent of historic coastal wetlands in California have been lost due to filing, dredging, flood control and intensive development. Within the Lower Ballona Creek Watershed, remaining fragmented wetland areas have been degraded due to diminished hydraulic function, poor water quality and introduction of exotic plants and animals. While functioning wetland systems and riparian habitat remain, they are stressed. Channelization of the Ballona Creek and filling of historic wetland and riparian areas have contributed to degradation and loss of habitat due to impeded tidal exchange and circulation. Contaminated stormwater runoff and trash loading has degraded Ballona Creek water quality. Habitat alteration and loss has decreased biodiversity and overall ecological health, threatening the survival of native endangered species such as the California least tern (*Sterna antillarum brown*), snowy plover (*Charadrius alexandrinus*), and the Belding's Savannah Sparrow (*Sandwichensis beldingi*). The current design of the Flood Control channel has resulted in a lack of recreational opportunities and is considered aesthetically challenged. At present there is no integrated approach and partnership amongst stakeholders to resolve lower Ballona Creek in-stream and wetland

degradation issues, which has led to uncoordinated and sometimes redundant and unsuccessful improvement measures. 4. Proposed Action and Alternative The Los Angeles District will investigate and evaluate all reasonable alternatives to address the problems and need stated above. In addition to a without project (No Action) Alternative, both structural and non-structural environmental measures will be investigated. An assessment of the feasibility of removing impervious surfaces from the Ballona Channel will also be evaluated. Proposed restoration measures include: re-grading and removal of fill, remove invasive and non-native plant species, reintroduction of a water source and installation of native plants to restore previously filled coastal wetlands. Other measures to be evaluated include features to improve or restore tidal regime in Oxford Basin, the Grand and Venice canals, and Ballona and Del Rey Lagoons; the potential for in stream wetland development in Centinela, Sepulveda and Ballona Creek; sediment loading in the upper watershed; and related recreation and educational opportunities. 5. Scoping Process The scoping process is on-going, and has involved preliminary coordination with Federal, State, and local agencies and the general public. A public scoping meeting is scheduled for Thursday September 29th from 6-8 p.m. at the Rotunda Room of the Veteran's Memorial Building, 4117 Overland Avenue, Culver City, CA. This information is being published in the local news media, and a notice is being mailed to all parties on the study mailing list to ensure that public will have an opportunity to express opinions and raise any issues relating to the scope of the Feasibility Study and the Environmental Impact Study/Environmental Impact Report. The public as well as Federal, state, and local agencies are encouraged to participate by submitting data, information, and comments identifying relevant environmental and socioeconomic issues to be addressed in the study. Useful information includes other environmental studies, published and unpublished data, alternatives that could be addressed in the analysis, and, potential mitigation measures associated with the proposed action. All comments will be considered in the project development. Concerns may be submitted in writing to the Santa Monica Bay Restoration Commission, or to the Los Angeles District (see ADDRESSES). Comments, suggestions, and request to be placed on the mailing list for announcements should be sp101.usace.army.mil. Availability of the Draft EIS/EIR The Draft EIS/EIR is scheduled to be published and circulated in December 2007, and a public hearing to receive comments on the Draft EIS/EIR will be held after it is published. Dated: September 13, 2005. Alex C. Dornstauber, Colonel, U.S. Army, District Engineer. [FR Doc. 05-18651 Filed 9-19-05; 8:45 am] BILLING CODE 3710-KF-M

**From:** Shelley Luce  
**To:** Mary Small; "Rick Mayfield"  
**Cc:** "Terri Stewart"  
**Subject:** RE: From John Davis Re Ballona CEQA process  
**Date:** Tuesday, February 07, 2012 1:39:26 PM

---

Agreed. The doc he references was for a completely different project, a feasibility study in which SMBRC was the local sponsor for the Corps' study. The EIR/EIS that we want to start is for a separate project, i.e. the BWER restoration/enhancement project. As the landowner, DFG will be the lead agency.

*Shelley Luce, D.Env.  
Executive Director  
Santa Monica Bay Restoration Commission  
Pereira Annex MS:8160  
1 LMU Drive, Loyola Marymount University  
Los Angeles, CA 90045  
310-961-4444*

[www.santamonicaabay.org](http://www.santamonicaabay.org)

---

**From:** Mary Small [mailto:msmall@scc.ca.gov]  
**Sent:** Tuesday, February 07, 2012 1:30 PM  
**To:** 'Rick Mayfield'; Shelley Luce  
**Cc:** 'Terri Stewart'  
**Subject:** RE: From John Davis Re Ballona CEQA process

Suggested response.

- 1) The EIS/EIR process begun in 2005 was for the Army Corps' Lower Ballona Ecosystem Restoration Feasibility Study, that project and the associated environmental review has not been completed and is not moving forward at this time. The EIR/S process for the proposed enhancement project will be separate.
- 2) The CEQA statute where lead agency is defined is Public Resources Code Section 21000.
- 3) DFG as landowner intends to be the lead agency on the proposed enhancement project that will be analyzed in the EIR/EIS.

---

**From:** Rick Mayfield [mailto:rmayfield@dfg.ca.gov]  
**Sent:** Tuesday, February 07, 2012 9:30 AM  
**To:** Mary Small; Shelley Luce  
**Cc:** Terri Stewart  
**Subject:** Fwd: From John Davis Re Ballona CEQA process

Please take a look at the attached from Mr. Davis and let me know if you can provide any further information before I respond.

Thanks,

Rick

>>> <jd@johnanthonydavis.com> 2/6/2012 5:11 PM >>>

Ca DFG  
Att: Mr. Mayfield

Hi Mr. Mayfield, attached is the congressional and corp docs we discussed.

The document states an joint EIS/EIR process was begun in 2005 per the request of Congress.

The Santa Monica Bay Restoration Commission is noted as the lead agency for CEQA in the joint EIR/EIS.

It also states that at least one scoping hearing has already occurred.

My question is does DFG plan on beginning another EIR process for the same area that is already been started by the SMRBC and Corp. If so, how can there be two lead agencies.

To me, logic indicates the SMRBC should be lead.

Thanks,

John Davis  
PO 10152  
Marina del Rey Ca. 90045

**From:** Mary Small  
**To:** "Diana Hurlbert"; "David Lawhead (DLawhead@dfg.ca.gov)"; "Eichler, Monica SPL"; "Eric Gillies"; "griggsp@slc.ca.gov"; "Hamamoto, Bruce"; "Patrick Holland (pholland@dpw.lacounty.gov)"; "Rick Mayfield (rmayfield@dfg.ca.gov)"; "Serao, Phillip J SPL"; "Shelley Luce"; "Strum, Stuart R MVN-Contractor"; "Swenson, Daniel P SPL"; "Terri Grant (tgrant@dpw.lacounty.gov)"; "Youn Sim (ysim@dpw.lacounty.gov)"  
**Subject:** FW: request for services - ballona wetlands  
**Date:** Wednesday, February 08, 2012 4:46:00 PM  
**Attachments:** [Ballona Civil Engineering and Geotech.pdf](#)  
[Ballona Hydrology and Engineering.pdf](#)

---

The request for services for the civil engineering and geotechnical contract and the hydrology and engineering contracts went out today. Feel free to forward to other potential contractors, I sent it to about 60 in our database and we will post it on the web. Proposals are due on Feb 29<sup>th</sup>.

Mary

---

**From:** Mary Small [mailto:msmall@scc.ca.gov]  
**Sent:** Wednesday, February 08, 2012 4:39 PM  
**Subject:** FW: request for services - ballona wetlands

The California State Coastal Conservancy is requesting proposals for consultant services for two separate contracts related to the proposed enhancement of the Ballona Wetlands Ecological Reserve in Los Angeles County. Services are needed to complete engineering and geotechnical evaluations, hydrology, technical studies, design and related services to support completion of a project level EIR/EIS and preparation and processing of a Section 408 permit through the Army Corp of Engineers. One contract will be for Civil and Geotechnical Engineering and a second contract will be for Hydrology and Engineering Design Analysis.

~~~~~  
Mary Small  
Deputy Executive Officer, Coastal Conservancy  
1330 Broadway #1300 Oakland, CA 94612  
510-286-4181



Ballona Ecosystem Restoration Planning Management Meeting  
June 28, 2010  
3:00-5:00pm

Attendees:

|                       |                                            |                           |
|-----------------------|--------------------------------------------|---------------------------|
| Josephine Axt, USACE  | Ed Demesa, USACE                           | Julian Serafin, USACE     |
| Rene Vermeeren, USACE | Ben Nakayama, USACE                        | Rhiannon Kucharski, USACE |
| Diana Hurlbert, SMBRC | Sean Bergquist, SMBRC                      | Kathy Anderson, USACE     |
| Larry Smith, USACE    | Mary Small, Coastal Conservancy (by phone) |                           |

- I. Mary Small: Coastal Conservancy is supplying most of the funding toward the in-kind local sponsor efforts.
- II. Ed Demesa: Corps Process Overview
  - a. We are coming up to our first major milestone (F3)
    - i. Baseline and future without project conditions; preliminary alternatives analysis
      1. Describes problems and opportunities, planning objectives
      2. This product will be the basis for future steps
    - ii. Next milestone (F4A/F4)
      1. Formulation, evaluation and comparison of alternatives
      2. F4A: SPD requirement, Alternative Formulation Briefing
    - iii. (F5) Public Draft Feasibility Report
      1. Headquarters Policy and Public Review
  - b. Josephine Axt: New Review Guidance (Estimated at \$500,000; IEPR is federally funded)
    - i. Agency Technical Review (ATR) - Requires coordination with the planning center of expertise, and coordinates a team of reviewers from another Corps Division
    - ii. Model certifications required
    - iii. Independent External Peer Review (IEPR)
    - iv. Note for budget: call out what IEPR is estimated to cost, and that it does not have to be cost shared
    - v. Diana Hurlbert: Under each discipline, there are costs for responding to comments. Are those related to ATR?
      1. Josephine Axt: Yes. There is a formal comment and response system that must be used for ATRs (DrChecks)
  - c. Kathy Anderson: Partnership
    - i. Communication
      1. Sean Bergquist: Communication has been much better since Rhiannon has taken over as Lead Planner.
      2. Mary Small: Rhiannon has been great in communication.
    - ii. Cost share
      1. Sean Bergquist: Our cost share component is 100% in-kind. It is anticipated that most of that work is and will continue to be in the wetlands.
        - a. We are finished our F3 equivalent (2006)
        - b. We are also finished our alternatives development and analysis (2008)
          - i. We want to make sure that all of the products feed in to the Corps process and products.
        - c. The Corps and us on not on the same timeline.

2. Mary Small: It was always our understanding that the Corps would use our restoration alternatives. It makes us nervous that this was never in writing. We have done our F4 equivalent.
  3. Because of Federal funding starts and stops, the Corps is still in the F3 process, while the sponsor has completed alternatives analysis (F4 equivalent).
  4. Diana Hurlbert: We want to make sure you are maximizing our products, and we want to understand what if any deficiencies are found.
  5. Josephine Axt: In-kind has to be formally submitted, directly applicable to the project and it must be understood that in-kind increases increase the overall budget increases.
    - a. Mary Small: We fear that our in-kind is not properly reflected in the PMP.
    - b. Rhiannon Kucharski: This may be the case. We need to go in detail in to this upon receipt of in-kind submissions, quality check them and revisit the PMP.
  6. Sean Bergquist: For credit, do we get credit for what we paid or for what it would have cost the Corps to do the same work?
    - a. Josephine Axt: The in-kind credit needs to match the estimate for that work in the PMP. Likewise, if the work costs more than estimated, credit will only be given for up to the estimated amount.
- iii. Ed Demesa: As the project goes up the chain, we have to be careful for policy issues. When the project is competing nationally, it starts to become a factor. The cost of land acquisition is part of the project costs. We can only credit up to 35% of total project costs.
  - iv. Mary Small: If the Corps falls too behind, we will work with Corps Regulatory for a permit for their activities (NEPA/CEQA, design, permitting, and Phase I construction).
    1. Josephine Axt: If you are going full steam ahead, what is your timeline?
    2. Sean Bergquist: We purchased the property in 2005, and have to do something with the property in the near future. There is no set deadline, but they must show the state that something is being done.
      - a. In about 4 years, they would like to be constructing something.
      - b. Early phase: Do South portion of Area B, South of Jefferson and below Gas Company (low areas, reconnect tidal flows)
    3. Ed Demesa: The law to partially build a project and receive credit for a larger project applies only to flood control when there is imminent need. Unfortunately, that law does not apply to ecosystem restoration. There is not an authority for us to give credit for it down the line. So, this may be something you want to consider for a WRDA request to change the authorization.

### III. Project Status

- a. Corps is working on baseline (F3) right now. Due to H&H delays, the milestone will most likely happen early in FY11.
- b. PMP amendment
  - i. Study area
    1. Will be clearly defined in the PMP amendment (to the satisfaction of all parties).

- a. Definition: Ballona Creek from the Pacific Ocean to Cochran, Del Rey Lagoon; and Centinela and Sepulveda Channels from Ballona Creek to where they go underground.
  2. Grand canal is out.
  3. Sean Bergquist: We have always planned on the daylighted part of Ballona Creek up to Cochran.
  4. Coordination needs to go through Diana Hurlbert and Rhiannon Kucharski.
- ii. Costs
  1. Ed Demesa: For in-kind credit, it is important to let the PDT know what work the sponsor is doing, even if it will not be submitted for in-kind credit.
  2. Sean Bergquist: Historical analysis of the watershed is in the works. We are also working with UCLA to do a watershed budget.
  3. Sean Bergquist: When things have to be redone, how does the cost share work?
    - a. Hydraulic study
      - i. Rene Vermeeren: Our H&H models are in DRAFT form and have not yet had the first ATR. They are not ready for use on alternatives.
  4. SMBRC Governing Board will have to sign the PMP and FCSA amendments.
  5. In construction phase, can the cost of the land/property be used toward sponsor in-kind credit?
    - a. Kathy Anderson: Yes, as long as the constructed project uses those lands. The state paid \$140 million in 2005 for the property that makes up areas A, B and C.
- iii. In-kind submittals
  1. Mary Small: Is there really much more additional work that needs to be done to review the submittals? How much is left to be done by the Army Corps depends on the in-kind submittals?
    - a. Diana and Rhiannon can work together with each PDT member to work through these. Set up meetings ASAP.
    - b. Kathy Anderson: The whole PDT needs to sit down and go through the PMP, in-kind and costs step-by with SMBRC.
  2. Mary Small: I am worried about the water quality report in terms of the data being what is needed per the Corps and less worried about the write-up
    - a. Confirm with James Chieh that the data is what is needed.
- c. Kathy Anderson: Sponsor financial capability?
  - i. Even in light of cost increases, the sponsor has enough money to fund all of their study activities and even begin phase I construction (Area B).
  - ii. Corps needs to get details of sponsor plans for "phase I" in Area B and determine if this must be added as a future without project condition or not.

IV. Action items are noted in RED.

Lower Ballona Creek Ecosystem Restoration Study Monthly Coordination Meeting Minutes  
April 28, 2010  
10-11am

Attendees:

Mary Small, CC

Sean Bergquist, SMBRC

Rhiannon Kucharski, USACE

Kathy Anderson, USACE

James Chieh, USACE

- I. Comments to the DRAFT Corps F3 products and the DRAFT PMP update are due by the next coordination meeting, May 26, 2010.
  - a. Comment from Sean related to updated costs/project area: SMBRC considers lower Ballona Creek to be everything from Cochran Avenue to the Ocean.
  - b. Sean is concerned about how SMBRC can come up with matching funds and/or in-kind work for a study totaling \$6.2 million (the updated estimated study cost total)
    - i. Mary: We may not be able to get approval for the cost increases
- II. Frank Wu was not able to attend today's meeting. He will contact Mary and Sean independently to discuss his question on the Engineering and Design Section I, Task 3 from the PMP.
- III. In-kind submittals
  - a. Mary and Sean will try to submit the first set within one week.
- IV. Water Quality Analysis
  - a. Document forthcoming from SCCWRP (early June)
  - b. Document forthcoming from Geosyntech (June)
    - i. Delay due to 2 very dry seasons
  - c. Some data is already available on the website (Ballonarestoration.org)
    - i. Some prior reports from previous years are available
  - d. The Corps (James Chieh) will need to translate and analyze the data and put it into the Appendix Report.
    - i. Sean will send everything that is currently available to James Chieh, Cc Rhiannon ASAP. This will include the Geosyntech scope of work and cost estimate for water quality data analysis.
- V. Other Discussion
  - a. There will be a site tour with the Corps, URS and Sean on May 5, 2010.
  - b. Kathy: We were able to request \$345k for FY11, but need to get amended FCSA executed.
    - i. Mary: We need to credit in-kind work before amending the FCSA. We hope this will bring down the overall study cost.
- VI. Action items noted in ORANGE.

Ballona Coordination Meeting Minutes  
June 2, 2010  
10am

Attendees:

|                                 |                           |                          |
|---------------------------------|---------------------------|--------------------------|
| Mary Small, Coastal Conservancy | Diana Hurlbert, SMBRC     | Heather Schlosser, USACE |
| Julian Serafin, USACE           | Rhiannon Kucharski, USACE |                          |
| Ben Nakayama, USACE             | Robert Browning, USACE    | Robert Grimes, USACE     |

- I. In kind submittals
  - a. For In-kind submittals, Mary, Sean and Diana tried to break down the submittals per the PMP, but had a hard time. Please see in-kind spreadsheet submitted last week.
  - b. SMBRC and Coastal Conservancy will submit the In Kind Submittal sheets that correspond with each document from the website, along with reference to the document or file they correspond to and a link to that document on the web.
- II. PMP updates
  - a. Mary Small is concerned that the revised PMP does not reflect the products they have completed, and very concerned about the cost increases.
  - b. Mary Small: Have all the PMP sections looked at the same project area? Parts still refer to Ballona Lagoon, Grand Canal, Venice Canals and Oxford Basin, which are no longer in the study area.
    - i. All sections should include: Del Rey Lagoon; Areas A, B and C; Ballona Creek from the Ocean to Cochran; and Centinela and Sepulveda Channels from where they daylight to Ballona Creek.
  - c. Mary and Diana requested that the Corps add geographic location to the PMP amendment chapter. The scopes of work are confusing because they do not make the study area clear.
  - d. Mary: Why have the F3 economics costs gone up?
    - i. Ben Nakayama: Economics had to re-run their model due to the revised flood plain hence their cost increase. The potential flooded parcels went from 6000 to 600.
    - ii. Sponsor wants to understand why the economics costs for F3 doubled. The model was originally run at a larger scope (6000 parcels) and is now being re-run at a smaller scope (600 parcels). That should not cost double. There should be economies of scale.
    - iii. Ben Nakayama: The model had to be completely re-run for the new parcels. This along with added review costs are the reasons behind the cost increase.
  - e. Review Guidance has led to approximately \$505k in cost increases. \$260k of that is for Independent External Peer Review (IEPR), which is NOT cost shared. The other levels of review such as Agency Technical Review (ATR) and model certification ARE cost shared.
    - i. Rhiannon will send another copy of the review guidance.
  - f. The Coastal Conservancy is worried that there will be no political appetite to support a feasibility study at this cost level.

- g. The language in the PMP needs to itemize what the additional costs would go towards.
  - i. Rhiannon will send the detailed cost estimates from each PDT member.
- h. The Coastal Conservancy believes their GIS work should decrease the revised GIS costs.
  - i. This can be investigated further in conjunction with the in-kind review process. USACE will ask Dave Bianco to review the GIS products and scope and cost estimate after the formal in-kind submittal.

### III. Coordination

- a. Heather Schlosser: It is hard to assure proper coordination when the Corps is trying to complete the baseline F3 this year, while the sponsor is well in to alternatives analysis in the wetlands areas (A, B, C).
  - i. Mary and Diana, what do you see as the Corps' role in this feasibility study?
    - 1. Mary Small: The discussion was that the Corps would focus on the Creek (there aren't state funds for that) and that the wetlands study would go forward separate from the larger feasibility study, but feed in to the project as in-kind credit. The restoration of the wetlands (A, B, C) is being led by SMBRC in conjunction with the State of California.
    - 2. SMBRC and Coastal Conservancy are both interested in the Creek as well.
      - a. Heather Schlosser: Are you willing to cost share the implementation phase of a recommended alternative that includes the Creek and Wetlands?
      - b. Mary Small: Our funding strategy for implementing the restoration is the value of the land. However, the Coastal Conservancy's focus is the restoration planning at the wetlands.

### IV. Executive Management Meeting

- a. Aim to have this in June. SMBRC and Coastal Conservancy will send potential dates and times to Rhiannon Kucharski, who will coordinate with USACE management schedules.

Ballona Telecon Minutes  
March 29, 2010

Attendees:

|                                 |                        |                      |
|---------------------------------|------------------------|----------------------|
| Rhiannon Kucharski, USACE       | Kathy Anderson, USACE  | Larry Smith, USACE   |
| John Killeen, USACE             | James Chieh, USACE     | Frank Wu, USACE      |
| Julian Serafin, USACE           | Michael Hallisy, USACE | Patrick Singh, USACE |
| Mary Small, Coastal Conservancy |                        | Sean Berquist, SMBRC |

- I. Introductions
- II. PMP update
  - a. DRAFT SOW Amendment Chapter distributed
  - b. Cost estimates
    - i. Frank Wu: Coastal Engineering F3 Baseline Conditions
      - 1. Need to incorporate PWA information in to the appendix
  - c. SMBRC Board will have to buy off on the updated PMP and cost estimates
    - i. At this Thursday's meeting they are asking the Board to generally support the study
    - ii. Cost increase approval will have to come through the Coastal Conservancy's Board
  - d. FCSA amendment would come after the PMP update is complete
    - i. Have to work with Corps Legal Counsel and SMBRC Legal/Board
  - e. Study Area
    - i. For F4, the Corps suggests focused study area of A,B & C plus the Creek up to the I-405, and the Centinela Channel and Sepulveda Wash
      - 1. H&H and Survey and Mapping Sections believe this focused area is best due to cost considerations
      - 2. Per Frank Wu: Coastal Engineering work has focused on A, B, & C
    - ii. Sponsors feel that we need to keep Ballona Creek up to Cochran Boulevard. Otherwise, the map is okay.
  - f. Rhiannon and Kathy will set up a meeting between the sponsors and Survey and Mapping (Alan Nichols).<sup>1</sup>
  - g. URS and the Corps are in negotiations for the Plan Formulation and Environmental Appendix
- III. Corps work Audit
  - a. Environmental Resources Branch (ERB )
    - i. Review of sponsor work
    - ii. Fish survey of creek and channels
    - iii. Work with SAC on HEP evaluation
      - 1. Including scope of work to score A, B & C and the creek between the marsh areas
      - 2. Mary can re-start the Conservancy agreement with the SAC to possibly fund them.
        - a. Larry will send Mary the scope of work he has written.
  - b. Cultural Resources
    - 1. Write-up from PWA, which summarizes a library record search
      - a. Corps and Conservancy both feel that the write-up is inadequate

---

<sup>1</sup> Action Items marked in GREEN.

- b. NEPA agency coordination for cultural must be done by a federal agency; it cannot be done by the sponsor or their contractor.
        - i. Michael Bever and Bob Stark, with Jones and Stokes and John Killeen need to be in touch with eachother.
      - 2. John Killeen has completed a full record search in the last few months
        - a. He is re-writing the F3 input based on the new, more adequate record search.
      - 3. NOTE: Important burials located in the Northwest corner of Area C that have been determined eligible that will need serious consideration for avoidance or mitigation.
      - 4. Also, cultural will have to look at channel as a resource. Where we are pulling out channel, if we decide to, will have to be investigated by cultural.
  - c. Coastal Engineering
    - i. Draft F3 Appendix complete
  - d. Geotech
    - i. Diaz-Yourman contract
    - ii. Contract oversight
  - e. H&H
    - i. Baseline Hydrology and Hydraulic Appendices
    - ii. Baseline Groundwater Appendix
    - iii. Sedimentation will be done during F4 analysis due to funding availability
      - 1. PWA is looking at sedimentation modeling in their contract with the sponsor. Mary will send their scope of work.
    - iv. Water Quality Appendix – We are relying on this product from the sponsor (SCCWRP).
      - 1. Mary will get us the Appendix as it is available.
  - f. Socioeconomics
    - i. Efforts to date have been on the flood risk management component
      - 1. Originally the work was going to be done in-house, in L.A.
      - 2. Original structure inventory and database, site surveys
        - a. Subsequent to that work, the H&H floodplain mapping was updated with a fairly significantly reduced floodplain delineation, which demanded that the economics be updated. This update was based on the first revision of the draft Hydraulic Appendix
        - b. Update to the economics work will be done through Albuquerque District Economics Section
          - i. Finalize F3 analysis
        - c. FLO-2D data conversion to HEC format
          - i. Will be done through Sacramento District
  - g. PWA and Jones and Stokes are doing on-going work. Mary will send both scopes of work.
- IV. In-kind process (Kathy Anderson)
  - a. To date there has been no in-kind logged in to the Corps financial system. We need to catch up on that. It should be done yearly.
  - b. Update in-kind numbers in PMP and in cost summary spreadsheet.
    - i. List all in-kind work in a table with associated amount spent on the work, along with a list of work already scoped and contracted to be done. Also, Shelly Luce of SMBRC would need to sign the official submittal.



- I. Sponsor needs to keep records of the in-kind and the values in case of an audit.
  - ii. Mary Small: What is the best way to do that?
  - iii. Kathy Anderson: We can have a separate meeting to go through the in-kind line by line with Kathy, Rhiannon, Sean and Mary.
  - iv. Mary Small: Is it what we spend on the product that gets credited or is it what the federal government would have spent to do the same thing?
    1. It is up to the PDT to QA/QC the products and agree to the accounting both in amount and content.
    2. Coastal Conservancy would feel more comfortable if the in-kind is credited at the value they spent on the product.
- V. Coordination
- a. Corps requests going forward
    - i. Each PDT member needs to coordinate with their equivalent on the sponsor's contractor team(s)
      1. Rhiannon will send a PDT list to Sean and Mary so that coordination contacts can be filled in next to the corresponding PDT member(s).
  - b. Sponsor requests
    - i. Tie up the in-kind process and update more often
  - c. Our coordination meetings from now on will be the last Wednesday of every month at 10am.
- VI. Other Discussion
- a. Bike tour with Congresswoman Harman April 9<sup>th</sup>.
    - i. Kathy will forward info to Mary and Sean.

**DRAFT  
ITINERARY FOR  
COL R. MARK TOY  
MEETING WITH SANTA MONICA BAY  
RESTORATION COMMISSION AND  
VISIT TO BALLONA CREEK**

**26 MAY 2011**

**TIME/ACTIVITY**

**TRANSP/REMARKS**

**THURSDAY – 26 MAY 2011**

**UNIFORM: ACUs**

0830 Depart SPL for Loyola-Marymount  
University (LMU) – 1 LMU

Govt vehicle  
Driver: Phil Serpa  
Rick Leifield  
Josephine Axt

310-338-2700

PAX:

Monica Eichler  
Stuart Strum  
Dan Swenson

0920 Arrive LMU – Santa Monica Bay  
Restoration Commission Staff Office  
(SMBRC)

Location:  
University Hall  
Room ECC1857  
Note: Met by Stuart  
Strum and Dan  
Swenson

0930 Executive Management Meeting with  
SMBRC and California State  
Coastal Conservancy (CC)  
Los Angeles County Public Works  
Dr. Shelley Luce, Executive Director,  
SMBRB  
Mary Small, Deputy Executive Officer,  
Coastal Conservancy  
Mark Prestrella, Deputy Director

**TIME/ACTIVITY**

**TRANSP/REMARKS**

**THURSDAY – 26 MAY (Continued)**

Agenda:

- Introductions
- Project Overview – SMBRC/CC
  - o Project goals and regional importance
  - o Planning Process (Science Advisory Committee and Public Meetings)
  - o Proposed Project
  - o Schedule
  
- Partnership with Corps: Discussion (All)
  - o 408 Permit – Outstanding Questions
  - o Status of Feasibility Study
  - o Discussion of Future Coordination

1100 Depart for Ballona Creek Govt Vehicle  
PAX: See above Driver: Phil Serpa

1110 Ballona Creek Site Visit  
- Overview of the Site  
- Ballona Channel  
- Muted Tidal Wetland

SMBRC/CC and LAPW Participants:  
Dr. Luce, Mary Small and Mark  
Prestrella

1210 Depart for Ballona Creek for SPL Govt Vehicle  
PAX: See above Driver: Phil Serpa

Note: Lunch enroute

1330 Arrive SPL

**From:** [Mary Small](#)  
**To:** [Diana Hurlbert](#); [sluce@santamonicabay.org](mailto:sluce@santamonicabay.org)  
**Subject:** talking points ballona - scc board  
**Date:** Thursday, January 05, 2012 2:08:00 PM  
**Attachments:** [talking points ballona board item.docx](#)

---

Hi

Shelley, I am hoping that you will share the presentation of this item to the Conservancy board with me. Attached is an outline of what I am thinking we should cover, please take a look and give me your thoughts. My suggestion is that I'd introduce the project and you, you'd cover the need for restoration and the proposed project and then I could go through the details of the proposed action. I am thinking we will have a short (10ish slide) powerpoint with few words but good pictures. I can pull a draft of it together.

Diana, I am hoping you can fill in the highlighted sections in the attached to help me think about how to explain the work that will done if approved, why it's so expensive and why we are going with this approach, as opposed to phasing differently etc.

Thanks,  
Mary

## Outline for the presentation

(Mary)

### Background

- 600 acres owned by the state, DFG and State Lands
- Designated State Ecological Reserve
- Purchased for the purpose of wetland restoration

### Project Partners, introduce Shelley

(Shelley)

### Need For Restoration, Site Mgt

- Currently no open public access, very restricted
- Site management issues: homeless encampments, trespass, trash, eyesore

### Need for restoration, biology

- Very degraded ecological resources – key findings of baseline assessment
- Regional significance – wetland loss around SM Bay and throughout So CA

### Proposed project

- Description of grand vision
- Ecological benefits
- Sustainability – adaption to SLR, restoration of ecological processes
- Public access components

### Planning process to date 2 slides(?)

- Public and Science Based Process
- Evaluation of broadest possible range of alternatives
- Refinement and assessment of preferred alternative –ideas we rejected, scaling down due to cost considerations, planning for phased implementation

(Mary)

### Recommended action:

- 1) Authorization for a grant of \$250 K to SMBRC to fund their ongoing work to advance this restoration project, including continuation of data collection, agency coordination and technical review and oversight.
- 2) Authorization of \$6.25 million to be contracted by SCC through competitive environmental services contracts for specific technical studies that are needed to complete the environmental review and permitting.

### Description of the technical work (what will be done and why so expensive)

This authorization would provide funds for several specific scopes of work to support environmental impact review and permitting of the restoration project.

- Soils and Geotechnical assessment – Some soil sampling has been completed onsite, however the main cost for implementation of the project will be soil management. To

reduce construction costs, the project is designed to balance cut and fill onsite. To effectively implement that program, we have to have clear understanding of soil characteristics – which soils can be used to construct levees, which soils should be used to create upland habitat, etc.

- Landscape Architect to design public access improvements. Conceptual designs for public access improvements have been included in the project from the very start. Now that we have a project description for the land-form of the restoration, it will be important to design the public access improvements. One of the major benefits of this project will be to create a new natural area in the urban center of Los Angeles. We intend to design public access amenities
- Civil engineering – design of levees and construction details up to \_\_\_% details of proposed work...
- Hydraulics and Hydrology – evaluation of flood risk and uncertainty details of proposed work...

In addition to environmental impact review, this project will need the following permits: Coastal Commission CDP, LA RWQCB permit, and an Army Corps Section 408 permit. Much of the additional technical work that is recommended in this action will be needed to comply with the 408 permit process.

The 408 permit is a permit issued by the Corps to modify an existing flood control project. After Hurricane Katrina, these permit requirements became much stricter and more comprehensive. This permit will have to be approved in DC and will require that the project have \_\_\_% design completed. *Explain why so expensive...*

Over the past several months, the project management team has been in conversation with the ACOE and internally discussing the best path forward given the significant costs to complete the design and hydraulic/hydrology studies.

We considered several options of initial projects that would involve installation of tide gates or breaches rather than full levee removal. Tide gate projects were determined to be less desirable because they do not restore full tidal range, are unable to adapt to sea level rise and have higher maintenance costs. We also considered a moving forward only with a smaller Phase 1 project that would restore wetlands north of the channel.

This would reduce the design and technical review costs now, but if we were ever to implement the full restoration project, we would have to go through some of the permit processes again. Our estimate is that the total planning costs would increase by X-XX amt in the end.

Of course the actual amount will be determined through contractor selection process and evaluation of proposals, but we have based this recommendation on a comprehensive, conservative but complete estimate to finish all of the pre-project work.

Acknowledge Some Opposition

- Is restoration needed, impacts to existing resources?

Some individuals think that this site is providing important habitat as is. This is a case of shifting baselines, the site does provide some habitat, but is severely degraded. Example - data pt from Karina's work?: To restore estuarine wetlands at Ballona, the land needs to be reconnected to the ocean.

- Can project be done with volunteers and without bulldozers?

The project that we are recommending is enormous in scale. It involves uncovering the wetlands that were buried with the construction of the marina and that have been cut off from the ocean for almost 90 years. We will work to continue working with youth groups and volunteers to implement portions of this restoration.

- Money would be better spend buying small parcels in the neighborhood

Some neighbors to the project have advocated that the restoration of the wetlands is a poor investment and the bond money should be spent to acquire small parcels (each 3-5 acres) rather than to restore the ecological reserve.

Funds are limited to Ballona, consequences if not approved, who will pay for construction?

Conclusion:

Even though this is a major investment and a controversial project, your staff recommends that you approve it. The ecological restoration of the Ballona wetlands is a rare opportunity to bring back coastal wetlands and to develop an urban natural area that will enhance the lives of millions of Californians. To really restore this site we have to implement a big vision and in order to do that we

Questions I will need to be prepared to answer:

Consequences if not approved

Who will pay for construction?

Why not grant all funds to SMBRC?

## NOTES

Cost of other wetland restoration projects – engineering and environmental review

|                                                                              |         |
|------------------------------------------------------------------------------|---------|
| South Bay Salt Ponds Initial Planning, EIR and Phase I Design (15,000 acres) | \$23 M  |
| Batiquitos Lagoon                                                            | \$5 M   |
| San Elijo Lagoon                                                             | \$1.9 M |
| S San Diego Bay Salt Ponds                                                   | \$550K  |

Questions we need to answer:

Why is this so expensive?

How does it compare to the costs other wetland restoration projects?

Is it needed? Is it a waste of money?

Is this the right alternative?

Will there be more habitat destruction than restoration

Who will implement the project?

Wouldn't we be better off with ngos and volunteers?

What about long term management?

Key Points

Plan developed with extensive scientific review and public input

Plan goals: habitat restoration, sustainability, public access, lower maintenance cost

Funds are specific to Ballona



**From:** [Shelley Luce](#)  
**To:** [Mary Small](#)  
**Cc:** [Diana Hurlbert](#)  
**Subject:** RE: timelines...  
**Date:** Monday, January 30, 2012 4:44:09 PM

---

Let's meet downtown at 11 am at Bottega Louie, it's on the corner of 7<sup>th</sup> and Grand. We can eat or just have coffee for as long as we want there, and then head over. Sound good?

*Shelley Luce, D.Env.  
Executive Director  
Santa Monica Bay Restoration Commission  
Pereira Annex MS:8160  
1 LMU Drive, Loyola Marymount University  
Los Angeles, CA 90045  
310-961-4444*

[www.santamonicabay.org](http://www.santamonicabay.org)

---

**From:** Mary Small [mailto:msmall@scc.ca.gov]  
**Sent:** Monday, January 30, 2012 4:30 PM  
**To:** Shelley Luce  
**Cc:** Diana Hurlbert  
**Subject:** Re: timelines...

Great, let's meet before maybe 11?  
Downtown would be easy for me but I could also fly to LAX and meet at LMU, if we do that maybe we could meet a little earlier?

Sam can't make it, this rescheduled time didn't work for him.  
Mary

sent from my phone

On Jan 27, 2012, at 12:38, Shelley Luce <[sluce@santamonicabay.org](mailto:sluce@santamonicabay.org)> wrote:

I have kept the whole day open. You can Sam can tell us what works for you - meet earlier downtown or at LMU, anytime after 9:30 is good for me. We can reserve a conf room at water board offices or meet at a coffee shop if we do it downtown.

*Shelley Luce, D.Env.  
Executive Director  
Santa Monica Bay Restoration Commission  
Pereira Annex MS:8160  
1 LMU Drive, Loyola Marymount University  
Los Angeles, CA 90045  
310-216-9827  
[www.santamonicabay.org](http://www.santamonicabay.org)*

---

**From:** Diana Hurlbert  
**Sent:** Friday, January 27, 2012 10:07 AM  
**To:** Mary Small; Shelley Luce  
**Subject:** RE: timelines...

The 1<sup>st</sup> works for me. As for timeline this is what I am shooting for....

Early Feb for Nick's revised engineering/construction PD  
Late Feb/early March for summary NOP/NOI to be circulated  
March/April for Habitat/Adaptive Mgmt Plan  
Early May for draft geotech, recreation/Area C, hydraulics, traffic, and 30% engineering/design  
Working over summer on & circulating admin draft chapters and finalizing reports, recreation/Area C etc.  
Finalizing Public review Draft for circulation in late Sept.

Please keep in mind that we will be creating and circulating draft chapters for review as information is available. All document preparation will be on concurrent paths. Keeping to the timeline depends mostly on how responsive reviewers are to deadlines for comment (ie. a 2 week turn around). The consultants are all aware of these targets and have committed to meeting them.

---

**From:** Mary Small [mailto:msmall@scc.ca.gov]  
**Sent:** Thursday, January 26, 2012 3:24 PM  
**To:** Shelley Luce  
**Cc:** Diana Hurlbert  
**Subject:** Re: timelines...

Hi

Sorry if I misspoke I feel like I have promised dates that we haven't met so many times that I instinctively underestimate when we'll get things done. It would be super valuable to have some key milestones on a schedule that we all are working off of- MRCA asked for that too. I can draft it up next week or you guys can send it to me.

I think there may be a role for Sci input going fwd but after I'm not sure I think we should have more SAC mtgs. Do you guys have time on the 1st? I think there are a few things we should touch base on and I could meet before or immediately after our mtg w ACOE.

Thanks  
Mary

sent from my phone

On Jan 26, 2012, at 15:47, Shelley Luce <[sluce@santamonicabay.org](mailto:sluce@santamonicabay.org)> wrote:

Hi Mary,

I wanted to check in on our timelines but I forgot to mention yesterday. I've been shooting for end of Feb. release of the NOP/NOI and public review draft of EIR/EIS in Sept. 2012. In the SAC meeting I thought I heard you say something longer than that – a few months until the NOP comes out. Also in the SAC meeting we kind of indicated there could be more SAC meetings to resolve

things that we were discussing and I didn't think that was part of our plan. I do think we can continue discussion of relevant things with SAC members as we write the draft EIR, and reconvene if necessary. Is that what you were thinking?

Talk to you Monday!  
Shelley

*Shelley Luce, D.Env.  
Executive Director  
Santa Monica Bay Restoration Commission  
Pereira Annex MS:8160  
1 LMU Drive, Loyola Marymount University  
Los Angeles, CA 90045  
310-961-4444*

[www.santamonicabay.org](http://www.santamonicabay.org)

**From:** Mary Small  
**To:** "Shelley Luce"  
**Subject:** LA Co  
**Date:** Tuesday, December 13, 2011 9:14:00 AM

---

Hi

Do you think there is any chance that we could get a commitment from LA Co to fund the permit process before Jan? Then I could add them as matching funds to my staff report.

Mary

~~~~~

Mary Small  
Deputy Executive Officer, Coastal Conservancy  
1330 Broadway #1300 Oakland, CA 94612  
510-286-4181

**From:** [Mary Small](#)  
**To:** "[Mary Small](#)"; "[Shelley Luce](#)"  
**Cc:** "[Diana Hurlbert](#)"  
**Subject:** RE: draft agmt SMBRF 2  
**Date:** Monday, February 13, 2012 9:28:00 AM

---

Hi

Can you let me know if this looks basically ok so I can send it to Mr. Davis?

Thanks

Mary

---

**From:** Mary Small [mailto:[msmall@scc.ca.gov](mailto:msmall@scc.ca.gov)]  
**Sent:** Tuesday, February 07, 2012 2:28 PM  
**To:** 'Shelley Luce'  
**Cc:** 'Diana Hurlbert'  
**Subject:** draft agmt SMBRF 2

Hi Shelley

Attached is a draft of the grant agmt to the SMBRF for the \$240K. We'll need to develop a work plan and budget separately.

Can you take a quick review and let me know if it looks ok? Elena has asked me to produce this draft quickly as it seems the best way to respond to our most recent PRA from Mr. Davis.

Thanks

Mary

**ATTACHMENT 6**



## REQUEST FOR SERVICES

### **Ballona Wetlands Ecological Reserve Environmental Analysis and Permit Assistance**

May 11, 2009

**Contract Type:** Environmental Professional Services

**Scope:**

Perform environmental analysis and assist in applying for permits for habitat enhancement and public access improvements at the Ballona Wetlands Ecological Reserve in Los Angeles.

**Submittal Deadline: June 1, 2009**

Proposals should be submitted electronically in adobe acrobat format and must be received at the Conservancy by June 1, 2009.

**Contact:** Mary Small, California Coastal Conservancy, [msmall@scc.ca.gov](mailto:msmall@scc.ca.gov)

**From:** [Mary Small](#)  
**To:** ["Ivan Medel"](#)  
**Cc:** ["Shelley Luce"](#); ["Karina Johnston"](#); ["Diana Hurlbert"](#)  
**Subject:** FW: post to web?  
**Date:** Wednesday, February 08, 2012 4:48:00 PM  
**Attachments:** [Ballona Civil Engineering and Geotech.pdf](#)  
[Ballona Hvdrology and Engineering.pdf](#)

---

Hi Ivan

Could you post the following on the homepage of the Ballona Restoration Project website?

The California State Coastal Conservancy is requesting proposals for consultant services for two separate contracts related to the proposed enhancement of the Ballona Wetlands Ecological Reserve in Los Angeles County. Services are needed to complete engineering and geotechnical evaluations, hydrology, technical studies, design and related services to support completion of a project level EIR/EIS and preparation and processing of a Section 408 permit through the Army Corp of Engineers. One contract will be for Civil and Geotechnical Engineering and a second contract will be for Hydrology and Engineering Design Analysis.

***Please unhighlight the text above but insert hyperlinks to the attached docs to the highlighted text to the RFS, does that make sense?***

Thanks,  
Mary



## **REQUEST FOR SERVICES**

### **Ballona Wetlands Ecological Reserve Civil and Geotechnical Engineering and Permit Assistance**

February 8, 2010

**Contract Type:** Civil Engineering and Geotechnical Professional Services

**Scope:** Provide engineering and geotechnical evaluations, design and related services for the proposed wetland restoration design of the Ballona Wetlands Ecological Reserve in Los Angeles. Technical studies, evaluations, and designs will be of sufficient detail to support completion of a project level EIR/EIS and preparation and processing of a Section 408 permit through the Army Corp of Engineers.

**Submittal Deadline: February 29, 2012**

Proposals should be submitted electronically in adobe acrobat format and must be received at the Conservancy by February 29, 2012.

**Contact:** Mary Small, California Coastal Conservancy, [msmall@scc.ca.gov](mailto:msmall@scc.ca.gov)

**From:** Mary Small  
**To:** "Diana Hurlbert"; "David Lawhead (DLawhead@dfg.ca.gov)"; "Eichler, Monica SPL"; "Eric Gillies"; "griggsp@slc.ca.gov"; "Hamamoto, Bruce"; "Patrick Holland (pholland@dpw.lacounty.gov)"; "Rick Mayfield (rmayfield@dfg.ca.gov)"; "Serpa, Phillip J SPL"; "Shelley Luce"; "Strum, Stuart R MVN-Contractor"; "Swenson, Daniel P SPL"; "Terri Grant (tgrant@dpw.lacounty.gov)"; "Youn Sim (ysim@dpw.lacounty.gov)"  
**Subject:** RE: request for services - ballona wetlands  
**Date:** Thursday, February 09, 2012 5:02:00 PM

---

Hello all-

Here's some more information about the Coastal Conservancy's contractor selection process. It is a quick process and I am hoping PMT members will assist us so I want to be sure you are aware of the schedule.

I am really hoping the PMT will help in reviewing proposals and that staff from the County and Corp will participate on the selection panel. These contracts are for work to support the County's 408 submittal. Here's the schedule for the review/selection:

- Proposals will be submitted electronically to me on 2/29
- I will post them on a secure site by 3/1 for PMT review
- PMT will select the top 3 or 4 firms we'll interview for each contract by 3/5
- PMT will do a detailed review of the written proposals of the top proposals by 3/13
- Interviews will be in LA on 3/13 – all day

I am assuming the selection panel will be Diana, me, and a representative from the County and the Corps. If anyone else wants to spend March 13<sup>th</sup> interviewing firms, please let me know.

Mary

---

**From:** Mary Small [mailto:msmall@scc.ca.gov]  
**Sent:** Wednesday, February 08, 2012 4:46 PM  
**To:** 'Diana Hurlbert'; 'David Lawhead (DLawhead@dfg.ca.gov)'; 'Eichler, Monica SPL'; 'Eric Gillies'; 'griggsp@slc.ca.gov'; 'Hamamoto, Bruce'; 'Patrick Holland (pholland@dpw.lacounty.gov)'; 'Rick Mayfield (rmayfield@dfg.ca.gov)'; 'Serpa, Phillip J SPL'; 'Shelley Luce'; 'Strum, Stuart R MVN-Contractor'; 'Swenson, Daniel P SPL'; 'Terri Grant (tgrant@dpw.lacounty.gov)'; 'Youn Sim (ysim@dpw.lacounty.gov)'  
**Subject:** FW: request for services - ballona wetlands

The request for services for the civil engineering and geotechnical contract and the hydrology and engineering contracts went out today. Feel free to forward to other potential contractors, I sent it to about 60 in our database and we will post it on the web. Proposals are due on Feb 29<sup>th</sup>.

Mary

---

**From:** Mary Small [mailto:msmall@scc.ca.gov]  
**Sent:** Wednesday, February 08, 2012 4:39 PM  
**Subject:** FW: request for services - ballona wetlands

The California State Coastal Conservancy is requesting proposals for consultant services for two separate contracts related to the proposed enhancement of the Ballona Wetlands Ecological

Reserve in Los Angeles County. Services are needed to complete engineering and geotechnical evaluations, hydrology, technical studies, design and related services to support completion of a project level EIR/EIS and preparation and processing of a Section 408 permit through the Army Corp of Engineers. One contract will be for Civil and Geotechnical Engineering and a second contract will be for Hydrology and Engineering Design Analysis.

~~~~~

Mary Small  
Deputy Executive Officer, Coastal Conservancy  
1330 Broadway #1300 Oakland, CA 94612  
510-286-4181

**Subject:** RE: PUBLIC RECORDS REQUEST FROM JOHN DAVIS MARCH  
27, 2012

**From:** "Elena Eger" <eeger@scc.ca.gov>(Add as Preferred Sender)

**Date:** Wed, Mar 28, 2012 8:46 am

**To:** <jd@johnanthonydavis.com>

**Cc:** "Mary Small" <msmall@scc.ca.gov>, <:sschuchat@scc.ca.gov>

Dear Mr. Davis:

The Conservancy does not possess a responsive record to your request, below.

Sincerely,

Elena Eger

Senior Staff Counsel

California Coastal Conservancy

1330 Broadway, Ste. 1300

Oakland, CA 94612

510-286-4089 tele/voicemail

510-286-0470 fax

**From:** jd@johnanthonydavis.com [mailto:jd@johnanthonydavis.com]

**Sent:** Tuesday, March 27, 2012 5:55 PM

**To:** Elena Eger

**Cc:** 'Mary Small'; sschuchat@scc.ca.gov

**Subject:** RE: PUBLIC RECORDS REQUEST FROM JOHN DAVIS MARCH 27, 2012

California Coastal Conservancy

Re: Public Records Request

Please provide any statute which exempts the California Coastal Conservancy from the California Contract Code as it relates to the Agency entering into contracts of any type.

Thank you,

John Davis

----- Original Message -----

Subject: RE: PUBLIC RECORDS REQUEST FROM JOHN DAVIS MARCH 21, 2012

From: "Elena Eger" <[eeeger@scc.ca.gov](mailto:eeeger@scc.ca.gov)>

Date: Tue, March 27, 2012 5:27 pm

To: <[jd@johnanthonydavis.com](mailto:jd@johnanthonydavis.com)>

Cc: "Mary Small" <[msmall@scc.ca.gov](mailto:msmall@scc.ca.gov)>, <[sschuchat@scc.ca.gov](mailto:sschuchat@scc.ca.gov)>

Dear Mr. Davis:

Your request below does not constitute a request for a record pursuant to the Public Records Act. Rather, your request is for an analysis of statutory law. I am ethically prohibited from providing counsel to anyone other than my client. Assuming that you are not a lawyer, I am also ethically bound to suggest to you that you obtain your own counsel to advise you on such matters. You may utilize the California State Bar website for referrals to counsel at [www.calbar.ca.gov](http://www.calbar.ca.gov).

Sincerely,

Elena Eger

Senior Staff Counsel

California Coastal Conservancy

1330 Broadway, Ste. 1300

Oakland, CA 94612

510-286-4089 tele/voicemail

510-286-0470 fax

**From:** [jd@johnanthonydavis.com](mailto:jd@johnanthonydavis.com) [mailto:[jd@johnanthonydavis.com](mailto:jd@johnanthonydavis.com)]  
**Sent:** Tuesday, March 27, 2012 1:38 PM  
**To:** Elena Eger  
**Subject:** RE: PUBLIC RECORDS REQUEST FROM JOHN DAVIS MARCH 21, 2012

Hello,

Thank you for the citations. However, neither removes the requirement of the Coastal Conservancy to comply with Public Contract Code Sections 10140-10141 nor 10515-10518.

If the Conservancy is exempt from the California Contract Code, please inform me as to what statute or code provides for such an exemption.

John Davis

----- Original Message -----

Subject: RE: PUBLIC RECORDS REQUEST FROM JOHN DAVIS MARCH 21, 2012  
From: "Elena Eger" <[eeger@scc.ca.gov](mailto:eeger@scc.ca.gov)>  
Date: Tue, March 27, 2012 12:50 pm  
To: <[jd@johnanthonydavis.com](mailto:jd@johnanthonydavis.com)>  
Cc: "Schuchat, Sam" <[sschuchat@scc.ca.gov](mailto:sschuchat@scc.ca.gov)>, "Mary Small" <[msmall@scc.ca.gov](mailto:msmall@scc.ca.gov)>, "Dick Wayman" <[dwayman@scc.ca.gov](mailto:dwayman@scc.ca.gov)>, "Nadine Peterson" <[npeterson@scc.ca.gov](mailto:npeterson@scc.ca.gov)>, "Heather Baugh" <[heather.baugh@resources.ca.gov](mailto:heather.baugh@resources.ca.gov)>, <[king@resources.ca.gov](mailto:king@resources.ca.gov)>

Dear Mr. Davis:

This correspondence contains the Coastal Conservancy's (Conservancy) response to your March 21, 2012 Public Records Act request, below.

The Conservancy does not possess any responsive records to either of your numbered requests. However, we direct you to Government Code Sections 4525 *et seq.* and 14 California Code of Regulations Sections 13870 *et seq.* for our contracting process.

Sincerely,

Elena Eger

Senior Staff Counsel

California Coastal Conservancy

1330 Broadway, Ste. 1300

Oakland, CA 94612

510-286-4089 tele/voicemail

510-286-0470 fax

**From:** [jd@johnanthonydavis.com](mailto:jd@johnanthonydavis.com) [mailto:[jd@johnanthonydavis.com](mailto:jd@johnanthonydavis.com)]

**Sent:** Wednesday, March 21, 2012 2:11 PM

**To:** "Samuel Schuchat"; "John Laird"; 'Dick Wayman'; 'Nadine Peterson'; [carmenp@scc.ca.gov](mailto:carmenp@scc.ca.gov); [king@resources.ca.gov](mailto:king@resources.ca.gov)

**Cc:** John Chang

**Subject:** PUBLIC RECORDS REQUEST FROM JOHN DAVIS MARCH 21, 2012

California Coastal Conservancy

Att: Executive Director Sam Schuchat

California Coastal Conservancy

March 21, 2012

To: Governing Board and Management

Douglas Bosco  
Marisa Moret  
Ann Nothoff  
John Laird  
Susan Hancsh

Karen Finn

Bryan Cash

Noreen Evens

Joe Simitan

Anthony Cannella

Bill Mornning

Luis Alejo

Das Williams

CC  
John Chang State Controller

Att: Executive Director Schuchat, Please Send This Letter to All California Coastal Conservancy Governing Board and Management.

This is a request for public records made pursuant to the California Public Records Act. Each numbered item is a distinct request for public records.

1. Please provide any and all public records that demonstrate compliance with California Public Contract Code Section 10140-10141 in regard to the California Coastal Conservancy approval onf January 19, 2012 of File No. 04-088 which approved money to be disbursed for engineering, hydrologic analyses, geotechnical assessments, and public design.



2. Please provide any and all public records that demonstrate compliance with California Public Contract Code Section 10515-10518 in regard to the California Coastal Conservancy approval on January 19, 2012 of File No. 04-088 which approved money to be disbursed for engineering, hydrologic analyses, geotechnical assessments, and public design.

No such records have been requested or received by me to date.

See Attached Approval for File No. 04-088

Thank you,

John Davis  
PO 10152  
Marina del Rey Ca. 90295

## **PUBLIC CONTRACT CODE SECTION 10140-10141**

**10140. Public notice of a project shall be given by publication once a week for at least two consecutive weeks or once a week for more than two consecutive weeks if the longer period of advertising is deemed necessary by the department, as follows: (a) In a newspaper of general circulation published in the county in which the project is located, or if located in more than one county, in such a newspaper in a county in which a major portion of the work is to be done. (b) In a trade paper of general circulation published in San Francisco for projects located in County Group No. 1, as defined in Section 187 of the Streets and Highways Code, or in Los Angeles for projects located in County Group No. 2, as defined in said Section 187, devoted primarily to the dissemination of contract and building news among contracting and building materials supply firms. The department may publish the notice to bidders for a project in additional trade papers or newspapers of general circulation that it deems advisable.** 10141. The notice shall state the time and place for the receiving and opening of sealed bids, describing in general terms the work to be done and that the bids will be required for the entire project and for the performance of separate designated parts of the entire project, when the department determines that segregation is advisable.

# **PUBLIC CONTRACT CODE**

## **SECTION 10515-10518**

10515. (a) No person, firm, or subsidiary thereof who has been awarded a consulting services contract may submit a bid for, nor be awarded a contract on or after July 1, 2003, for the provision of services, procurement of goods or supplies, or any other related action that is required, suggested, or otherwise deemed appropriate in the end product of the consulting services contract. (b) Subdivision (a) does not apply to either of the following: (1) Any person, firm, or subsidiary thereof who is awarded a subcontract of a consulting services contract that amounts to no more than 10 percent of the total monetary value of the consulting services contract. (2) Consulting services contracts that comply with Article 2.5 (commencing with Section 10510.4). (c) (1) Subdivision (a) does not apply to any person, firm, or subsidiary awarded a consulting services contract by a University of California medical center when the provision of service, procurement of goods or supplies, or any other related action required, suggested, or otherwise deemed appropriate in the end product of the consulting services contract, is necessary to avoid a competitive disadvantage in the hospital industry, improve patient care, protect the privacy of patient information, or avoid significant delay and additional expense. (2) The University of California shall report within 30 days on any exemption granted under paragraph (1) to the Joint Legislative Budget Committee and the Department of Finance. The report shall include a description of the circumstances that warranted the exemption, the effects of the exemption on patient care or patient privacy, and a calculation of the projected costs savings to the institution as a result of the exemption. 10516. No officer or employee of the University of California shall engage in any employment, activity, or enterprise from which the officer or employee receives compensation or in which the officer or employee has a financial interest if that employment, activity, or enterprise is sponsored or funded, or sponsored and funded, by any university department through or by a university contract unless the employment, activity, or enterprise is within the course and scope of the officer's or employee's regular university employment. No officer or employee in the university shall contract on his or her own individual behalf as an independent contractor with any university department to provide services or goods. This section shall not apply to officers or employees of the university with teaching or research responsibilities, nor shall it apply to student employees for payment for additional campus activities or engagements outside of the scope of their primary university employment. 10517. (a) No retired, dismissed, separated, or formerly employed person of the University of California employed with the university or otherwise appointed to serve in the university may enter into a contract in which he or she engaged in any of the negotiations, transactions, planning, arrangements, or any part of the decisionmaking process relevant to the contract while employed in any capacity by any university department. The prohibition of this subdivision shall apply to a person only during the two-year period beginning on the date the person left university employment. (b) For a period of 12 months following the date of his or her retirement, dismissal, or separation from the University of California, no person employed in the university or otherwise appointed to serve in the university may enter into a contract with any university department, if he or she was employed by that department in a policymaking position in the same general subject area as the proposed contract within the 12-month period prior to his or her retirement, dismissal, or separation.

The prohibition of this subdivision shall not apply to a contract requiring the person's services as an expert witness in a civil case or to a contract for the continuation of an attorney's services on a matter he or she was involved with prior to leaving the university. (c) This section does not prohibit the rehire or reappointment of University of California employees after retirement, consistent with university administrative policies, nor does it apply to inventors and authors of intellectual property licensed under technology transfer agreements. 10518. (a) Except as otherwise provided in subdivision (b), each contractor who enters into a contract with a University of California campus for ten thousand dollars (\$10,000) or more shall be assigned an identification number by the chancellor of that university campus. Each contractor who has been assigned a number shall list it on each contract the contractor enters into with the university campus, regardless of the amount of the contract. In the case of a corporation or firm, the chancellor's assigned number shall be used exclusively on each contract with that particular chancellor's campus. The assigned number shall remain unchanged regardless of future name changes. (b) If the identification numbers cannot be tracked centrally by the Regents of the University of California, then the regents, and not the chancellors, shall assign the identification numbers.

**ATTACHMENT 7**

**From:** [Mary Small](#)  
**To:** ["Barbara Romero"](#)  
**Cc:** ["Melissa Guerrero"](#); ["Diana Huribert"](#); ["Shelley Luce"](#)  
**Subject:** SCC mtg in Jan  
**Date:** Monday, December 19, 2011 3:30:00 PM  
**Attachments:** [Ballona Wetlands Engineering and Technical Studies.docx](#)

---

Hi Barbara,

Thanks for agreeing to support the recommendation for funding for engineering work at Ballona. Attached is the draft staff report, the project will be heard at our Jan 19th meeting at the Baldwin Hills Scenic Overlook. As you can see it's a pretty big authorization, so we'd love your support. I think we may take the Board on a tour of Ballona that morning and then the meeting will start around 12:30. It would be great to have MRCA join us for either the tour or the meeting.

Thanks also for the message about the early action plan grant. When you have time submit any final billing or just a letter stating that the work is all done and I'll close it out.

Hope you are doing well and have a great holiday.

Mary

**From:** [Mary Small](mailto:Mary.Small)  
**To:** "Shelley Luce"; "Scott Valor"  
**Subject:** FW: support letter for SCC board meeting?  
**Date:** Wednesday, January 11, 2012 3:53:00 PM

---

Good news

---

**From:** Sarah Sikich [<mailto:ssikich@healthebay.org>]  
**Sent:** Wednesday, January 11, 2012 3:44 PM  
**To:** Mary Small  
**Subject:** RE: support letter for SCC board meeting?

Hi Mary,

Mark forwarded me your email about the Ballona technical study support letter for the SCC board meeting. We discussed it at our department meeting this week, and will send in a letter. Is an electronic copy fine, or do you need a hard copy? Also, should I just send it to you?

Additionally, Alix Hobbs would like to join our meeting while you are at Heal the Bay to discuss some of our Coastal Conservancy projects and potential future ideas. Is it okay with you if she joins for the second half of the meeting?

Thanks,  
Sarah

---

**From:** Mary Small [<mailto:msmall@scc.ca.gov>]  
**Sent:** Tuesday, January 03, 2012 3:00 PM  
**To:** Mark Gold  
**Subject:** RE: support letter for SCC board meeting?

Thanks, the meeting is the 19<sup>th</sup> so that's the deadline. Yes, I totally understand.

I was just sending Sarah an email about possible dates I'll be in LA when I'd like to stop in and talk about OPC, so maybe I'll see you then.

Happy new year (and MLPA implementation)  
Mary

---

**From:** Mark Gold [<mailto:mgold@healthebay.org>]  
**Sent:** Tuesday, January 03, 2012 2:39 PM  
**To:** Mary Small  
**Subject:** RE: support letter for SCC board meeting?

Mary – Happy new year to you too. We will definitely take a look at this and think it through. It is a great project and needs to happen. The political baggage that goes with it is no picnic as you know.

When is the deadline?

**ATTACHMENT 8**

**From:** [jd@johnanthonydavis.com](mailto:jd@johnanthonydavis.com) [mailto:[jd@johnanthonydavis.com](mailto:jd@johnanthonydavis.com)]  
**Sent:** Wednesday, March 21, 2012 12:34 PM  
**To:** "Samuel Schuchat"; "John Laird"; 'Dick Wayman'; 'Nadine Peterson'; [carmenp@scc.ca.gov](mailto:carmenp@scc.ca.gov);  
[king@resources.ca.gov](mailto:king@resources.ca.gov)  
**Cc:** David Lawhead; John Chang  
**Subject:** To All California Coastal Conservancy Board Members from John Davis

California Coastal Conservancy  
Att: Executive Director Sam Schuchat

California Coastal Conservancy

March 21, 2012

To: Governing Board and Management  
Douglas Bosco  
Marisa Moret  
Ann Nothoff  
John Laird  
Susan Hancsh  
Karen Finn  
Bryan Cash  
Noreen Evens  
Joe Simitan  
Anthony Cannella  
Bill Mornning  
Luis Alejo  
Das Williams

CC  
John Chang State Controller

Att: Executive Director Schuchat, Please Send This Letter to All California Coastal Conservancy Governing Board and Management.

Your Staff Attorney, Elena Eger has indicted this State Agency will not answer the fair questions I, as a member of the public asked regarding the procedures of the Conservancy.

Failure to answer such questions is contrary to the role of the State Agency to enjoin the public in the processes.

Please request that Staff respond to the questions I have asked.

Furthermore I have requested that your Staff not copy any Private Business or Individuals on responses to me as I consider it harassment and intimidation by the State Agency.

Should any such private business or individual wish to obtain such email records, such records should ONLY be provide if requests for such records are made pursuant to the Law, the California Public Records Act.



The Information Practices Act (Civil Code section 1798 et seq.) generally prohibits agencies from disclosing an individual's personal information to the public.

Thank you,

John Davis  
PO 10152  
Marina del Rey Ca. 90295

.....  
**From:** [jd@johnanthonydavis.com](mailto:jd@johnanthonydavis.com) [<mailto:jd@johnanthonydavis.com>]  
**Sent:** Thursday, February 16, 2012 1:29 PM  
**To:** Elena Eger  
**Cc:** 'Mary Small'; 'Sam Schuchat'; 'Dick Wayman'; 'Shelley Luce'; [svalor@santamonicabay.org](mailto:svalor@santamonicabay.org)  
**Subject:** Reply from John Davis RE: Davis' Requests for Information

California Coastal Conservancy  
Att: E.Eger  
Re: Reply

Dear E. Eger,

The request for public records submitted on 2/14/2012 remains outstanding.

The Commission still needs to reply to this request within 10 days of the submission date. I do expect a reply by 2/24/2012 as the Public Records Act requires under law.

I also would take issue with your recent email stating that I made a DEMAND of the Commission. This is far from true.

In fact my email stated the INTENDED PURPOSE of the email and made no demands as you stated to me in your email to me.

Prior to that, you inferred in another email that I made statements and or asserted things that I clearly did not.

I corrected you once already in writing, and find I must do so yet again.

Your accuracy in characterizing my telephonic conversations or written documents should not be clouded by your misconceptions as I do not find it to be professional in your role as a State Attorney.

Regards,

John Davis  
PO 10152  
Marina del Rey Ca. 90295

\*\*\*\*\*

**Subject:** Reply from John Davis RE: PUBLIC RECORDS REQUEST FROM JOHN DAVIS  
**From:** <jd@johnanthonydavis.com>(Add as Preferred Sender)  
**Date:** Tue, Feb 14, 2012 2:05 pm  
**To:** "Elena Eger" <eeeger@scc.ca.gov>

California Coastal Conservancy  
Att: Elana Eger Council  
Re: Reply to your communication

Counsel Eger,

Please pardon my typo in your title.

Also, I still do not understand why a State Agency would share my letter, and personal email address with a private business, unless requested pursuant to the Public Records Act. I am not sure what other private businesses you intend to copy on my letters to the State Agency using State facilities.

I do understand that you will continue to provide my emails to this State Agency with private businesses:

" Indeed, we will continue to share communications to you or from you with our other Ballona project partners, irrespective of whether the partner is a public or private organization, when we, at our sole discretion, determine that dissemination to be useful for our project purposes."

How does the Coastal Conservancy define the term "partner" as used in your statement?

How, at the Coastal Conservancy, is a determination made at its sole discretion whether the dissemination of my email to the State Agency would be useful for the Conservancy's project purposes?

What entity of the Coastal Conservancy is entitled to make such a determination and under what authority?

These are fair questions given that my letters to you have already been shared with a private business.

Thank you for your continued assistance.

John Davis  
PO 10152  
Marina del Rey Ca. 90295

----- Original Message -----

Subject: RE: PUBLIC RECORDS REQUEST FROM JOHN DAVIS

From: "Elena Eger" <[eeeger@scc.ca.gov](mailto:eeeger@scc.ca.gov)>  
Date: Tue, February 14, 2012 12:32 pm  
To: <[jd@johnanthonydavis.com](mailto:jd@johnanthonydavis.com)>  
Cc: "Mary Small" <[msmall@scc.ca.gov](mailto:msmall@scc.ca.gov)>, <[svalor@santamonicabay.org](mailto:svalor@santamonicabay.org)>,  
"Shelley Luce" <[sjluce@santamonicabay.org](mailto:sjluce@santamonicabay.org)>, "Dick Wayman"  
<[dwayman@scc.ca.gov](mailto:dwayman@scc.ca.gov)>

Mr. Davis:

This is in partial response to your PRA, below and your request of yesterday at 5:15 p.m. in which you demand that we not share your communications with "any private business" and in which you characterize such communications as "private".

While we will provide you with your requests to the extent possible and in compliance with the PRA, we must clarify to you that communications between you, as a member of the public, and the Conservancy, a public agency, are not considered under the PRA and thus not by the Conservancy to be "private communications", subject to any privilege or exception under the Act. Indeed, we will continue to share communications to you or from you with our other Ballona project partners, irrespective of whether the partner is a public or private organization, when we, at our sole discretion, determine that dissemination to be useful for our project purposes.

I would also like to clarify for you for your future purposes that my title is not "council" but "counsel", that is, I am a lawyer, not a member of a council.

Sincerely,

Elena Eger  
Senior Staff Counsel  
California Coastal Conservancy  
1330 Broadway, Ste. 1300  
Oakland, CA 94612  
510-286-4089 tele/voicemail  
510-286-0470 fax

\*\*\*\*\*

**From:** [jd@johnanthonydavis.com](mailto:jd@johnanthonydavis.com) [<mailto:jd@johnanthonydavis.com>]  
**Sent:** Tuesday, February 14, 2012 10:49 AM  
**To:** Elena Eger  
**Subject:** PUBLIC RECORDS REQUEST FROM JOHN DAVIS

California Coastal Conservancy  
Att: Council E. Eger  
Re: Public Records Request

This is a public records request made pursuant to the California Public Records Act. Each numbered item is a separate and distinct request for public records. This letter is only intended to for the California Coastal Conservancy and NOT FOR ANY PRIVATE BUSINESS, unless requested by such a business via the California Public Records Act.

1. Provide any and all emails to and received by the California Coastal Conservancy

from the following email address in regard and prior to Item 5 of the Conservancy hearing on January 19, 2012: [sluce@santamonicabay.org](mailto:sluce@santamonicabay.org)

2. Provide any and all emails to and received by the California Coastal Conservancy from the following email address in regard and prior to Item 5 of the Conservancy hearing on January 19, 2012: [svalor@santamonicabay.org](mailto:svalor@santamonicabay.org)

3. Provide any and all emails to and received by the California Coastal Conservancy from the following email address AFTER the Conservancy hearing on January 19, 2012: [sluce@santamonicabay.org](mailto:sluce@santamonicabay.org)

4. Provide any and all emails to and received by the California Coastal Conservancy from the following email address AFTER the Conservancy hearing on January 19, 2012: [svalor@santamonicabay.org](mailto:svalor@santamonicabay.org)

6. Provide any and all emails sent by the Conservancy to following email address in regard and prior to Item 5 of the Conservancy hearing on January 19, 2012: [sluce@santamonicabay.org](mailto:sluce@santamonicabay.org)

7. Provide any and all emails sent by the Conservancy to following email address in regard and prior to Item 5 of the Conservancy hearing on January 19, 2012: [svalor@santamonicabay.org](mailto:svalor@santamonicabay.org)

8. Provide any and all email sent by the California Coastal Conservancy to following email address in AFTER the Conservancy hearing on January 19, 2012: [sluce@santamonicabay.org](mailto:sluce@santamonicabay.org)

9. Provide any and all email sent by the California Coastal Conservancy to following email address in AFTER the Conservancy hearing on January 19, 2012: [svalor@santamonicabay.org](mailto:svalor@santamonicabay.org)

Thank you for your assistance,

John Davis  
PO 10152  
Marina del Rey Ca. 90295

----- Original Message -----

Subject: RE: Reply from John Davis RE: Davis' Requests for Information

From: "Elena Eger" <[eeger@scc.ca.gov](mailto:eeger@scc.ca.gov)>

Date: Thu, February 16, 2012 7:48 pm

To: <[jd@johnanthonydavis.com](mailto:jd@johnanthonydavis.com)>

Cc: "'Mary Small'" <[msmall@scc.ca.gov](mailto:msmall@scc.ca.gov)>, "'Sam Schuchat'" <[sschuchat@scc.ca.gov](mailto:sschuchat@scc.ca.gov)>, "'Dick Wayman'" <[dwayman@scc.ca.gov](mailto:dwayman@scc.ca.gov)>, "'Shelley Luce'" <[sluce@santamonicabay.org](mailto:sluce@santamonicabay.org)>, <[svalor@santamonicabay.org](mailto:svalor@santamonicabay.org)>

Dear Mr. Davis:

As I stated in my email of yesterday to you, we intend to comply with your records request to us of 2/14. We are working on compiling the records that you have requested. Please clarify whether you wish to receive the emails pertaining to correspondence among Mr. Valor, Ms. Luce and Conservancy staff with respect to the Item #5 on the 1-19-12 agenda only.

Please clarify that you are referring to the Conservancy when you make reference to the "Commission" in your message below.

As to your other allegations contained in your email below, I remind you that, as I said yesterday, we will make no further comment, which, of course, does not mean that we agree or disagree with your interpretations. Again, unless you are requesting a record from us under the Public Records Act, we do not intend to make further explanatory comments to you.

Sincerely,

Elena Eger  
Senior Staff Counsel  
California Coastal Conservancy  
1330 Broadway, Ste. 1300  
Oakland, CA 94612  
510-286-4089 tele/voicemail  
510-286-0470 fax

----- Original Message -----

Subject: Davis' Requests for Information

From: "Elena Eger" <[eeeger@scc.ca.gov](mailto:eeeger@scc.ca.gov)>

Date: Wed, February 15, 2012 6:45 pm

To: <[jd@johnanthonydavis.com](mailto:jd@johnanthonydavis.com)>

Cc: "Mary Small" <[msmall@scc.ca.gov](mailto:msmall@scc.ca.gov)>, "Sam Schuchat"

<[sschuchat@scc.ca.gov](mailto:sschuchat@scc.ca.gov)>, "Dick Wayman" <[dwayman@scc.ca.gov](mailto:dwayman@scc.ca.gov)>, "Shelley

Luce" <[sluce@santamonicabay.org](mailto:sluce@santamonicabay.org)>, <[svalor@santamonicabay.org](mailto:svalor@santamonicabay.org)>

Dear Mr. Davis:

In response to your inquiry below, I am providing you with the link to our website's contents of Item 5, Ballona Restoration Project, approved at the Conservancy's 1-19-12 public meeting unanimously. All my references are to the contents in this link. [http://scc.ca.gov/webmaster/ftp/pdf/sccbb/2012/1201/20120119Board05\\_Ballona\\_Wetlands.pdf](http://scc.ca.gov/webmaster/ftp/pdf/sccbb/2012/1201/20120119Board05_Ballona_Wetlands.pdf).

I believe in your message below you are referencing Exhibit 4. This record reads at the bottom of the page in the key: "Existing habitat units based on field survey conducted by the California Department of Fish and Game, October – December 2000. Map created by GreenInfo Network October 20, 2011." The Conservancy's logo is next to this statement.

With respect to the remainder of your email to us, below, except for our response to your last statement regarding the Conservancy's

dissemination of your correspondence to and with us, which we responded to in my earlier email to you of yesterday at 11:32 a.m., we wish to direct your attention to the Public Records Act (PRA), which provides the public with the mechanism to request a public record from a public agency. Additionally, we wish to direct your attention to the Ballona Restoration website, linked on our Conservancy website at [www.scc.ca.gov](http://www.scc.ca.gov), which among other resources, has project documents and provides a calendar of upcoming meetings, if any, where you have the opportunity to seek clarification and information regarding the restoration project.

We have cooperatively provided you with both oral and written clarifications on requests you have made to us for information or on allegations you have made that we or our project partners are violating particular laws or practices or conducting our respective project business improperly. In fact, since the Conservancy unanimously approved Item 5 for Ballona Restoration Planning, on 1-19-12, we responded to every one of your requests for records under the PRA or for explanations or to answer your allegations, which now amount to some 16 written requests to date for both information and records in the 18 business days from our 1-19-12 meeting, except for two requests for information and one request for records, received yesterday. Additionally, you have spoken by phone with six of our staff numerous times each, none of which were records requests but were rather in the nature of your seeking more information or explanation from us. Despite our willingness to provide you with explanations and/or clarifications, we continue to receive more requests for the same information from you, often accompanied by accusations of improper behavior.

In compliance with our obligations under the Public Records Act, we will continue to provide our records to you upon written request for such records. However, we will not be responding to your further requests for non-record information or explanation or to your allegations of improper business practices beyond this request, below. We cannot conduct our regular business in service of the public and continue to respond to your almost-daily and, if daily, often numerous daily requests for non-record information or to answer your allegations. Despite our willingness to provide you with explanations, clarifications and information, our good-faith responses back to you seem to be unsatisfactory to you since you follow-up often with yet another request for the same information. Continuing this "asked and answered" process seems an unproductive use of public resources. So, with respect to your statement that DFG produced this map, please note that as cited above here, GreenInfo Network produced the map for the Conservancy and its project partners/team's use; DFG is

our restoration partner on this project. We direct you to the Conservancy's website at [www.scc.ca.gov](http://www.scc.ca.gov), Ballona restoration for identification of our project partners on this project.

With respect to whether DFG provided the Conservancy with permission to put our logo on this proposed restoration design, please note that the Conservancy is a project partner with DFG and that within this partnership, the Conservancy acts as the lead in restoration planning with the full agreement of the other project partners, including the DFG.

Sincerely,

Elena Eger  
Senior Staff Counsel  
California Coastal Conservancy  
1330 Broadway, Ste. 1300  
Oakland, CA 94612  
510-286-4089 tele/voicemail  
510-286-0470 fax

**From:** [jd@johnanthonydavis.com](mailto:jd@johnanthonydavis.com) [<mailto:jd@johnanthonydavis.com>]  
**Sent:** Monday, February 13, 2012 5:15 PM  
**To:** 'Elena Eger'  
**Cc:** 'Nadine Peterson'; 'Sam Schuchat'; 'Dick Wayman'; Mary Small  
**Subject:** RE: Davis call to Eger of 2-6-12

California Coastal Conservancy  
Att: Elena Eger Legal Council  
CC Mary Small Project Manager  
Re: Item 5 January 19th 2012 Meeting

Hello Council Eger,

Mary Small directed me to you to answer a question about the hearing noted above.

The attached map was presented as a projection.

It bears the seal of the State Coastal Conservancy. The small text below the legend is hard to read but it does reference the California Dpt. of Fish and Game in 2011. The text is not clear. It appears to say Ballona Wetlands units.....summary conducted the California Dpt of Fish and Game .....Map created by .....October 20, 2011.

Could you provide the correct reading of this text?

For what purpose did Fish and Game produce this map?

Did Fish and Game provide specific permission for the Conservancy to place its seal (logo) on this

map for official purposes such as for grant approvals?

I understand the Conservancy is a partner of Fish and Game in the Ballona preserve.

However it is unclear if Fish and Game authorized the use of this map for purposes of another Agency to consider in its grant process.

Please DO NOT CC ANY PRIVATE BUSINESSES ON MY E-Mail COMMUNICATIONS anymore. This is met to be a private communication between myself and the State Agency, and not to be shared with any private business, whatsoever.

Again,

Thank you for your assistance,

John Davis  
PO 10152  
Marina del Rey Ca. 90045



**From:** [Mary Small](#)  
**To:** ["Elena Eger"](#)  
**Cc:** ["Scott Valor"](#)  
**Subject:** FW: State Water Board Legal's Memo to our Governing Board  
**Date:** Monday, February 06, 2012 4:47:02 PM  
**Attachments:** [SWRCB memo2011aug re accusations.pdf](#)  
[SWRCB Ltr to Davis re PRAs.pdf](#)

---

Hi Elena

Scott Valor emailed this to you but he had the wrong address.

Mary

---

**From:** Scott Valor [mailto:[svalor@santamonicabay.org](mailto:svalor@santamonicabay.org)]  
**Sent:** Monday, February 06, 2012 3:42 PM  
**To:** [msmall@scc.ca.gov](mailto:msmall@scc.ca.gov); [eeeger@scc.ca.gov](mailto:eeeger@scc.ca.gov)  
**Subject:** State Water Board Legal's Memo to our Governing Board

Mary & Elena--

The attached memo to our Governing Board may help with some background. It was not only given to our Governing Board, it is posted on our website, and was forwarded to John Davis and Patricia McPherson, among others. It addresses virtually all of the accusations made against the Foundation and Commission.

Attached also is a direct letter to John Davis from SWRCB legal noting how Foundation staff and contractors legally serve the SMBRC. For example, I am a contractor to the Foundation, but I am authorized to act on behalf of the Commission. He refuses to acknowledge that, which will never change. However, the documents speak for themselves.

One reason he may be contacting you (again) is that SWRCB legal told him that any future PRA queries to the Commission must be directed to me. He simply won't do that so he seeks ways around it. It would be entirely appropriate for you to re-direct any queries relevant to the SMBRC to me.

Call me if/when questions arise.

/s

Scott Valor  
Director of Government Affairs  
Santa Monica Bay Restoration Commission  
310-922-2376

visit us at [www.smbrc.ca.gov](http://www.smbrc.ca.gov)



**SIERRA  
CLUB**  
FOUNDED 1892

Angeles Chapter  
Airport Marina Regional Group  
3435 Wilshire Blvd., Ste. 320  
Los Angeles, CA 90010

August 16, 2012

**U.S. Army Corps of Engineers**

Los Angeles District  
915 Wilshire Blvd, Suite 1101  
Los Angeles, CA 90017  
Att: Col. Mark Toy Commander Los Angeles District  
Att: Dr. Daniel P. Swenson  
1416 9th St., 12th Floor

**California Dept. of Fish & Game**

1416 9th Street, 12th Floor  
Sacramento, CA 95814  
Att: Executive Director Charlton H. Bonham

Re: 2012 Notice of Joint EIS/EIR

This letter responds to the Notice of Intent to conduct a joint EIS/EIR pursuant to the National Environmental Policy Act and the California Environmental Protection Act at the Ballona Wetlands Ecological Preserve in the State of California, County of Los Angeles, in 2012.

The Club has resolved to support the joint EIR/EIS process noticed in the Federal Register on September 20, 2005 by the U.S. ACE Los Angeles District and the Santa Monica Bay Restoration Commission, a State Agency, as the local sponsor.

The position of the Club is that the new Notice of Intent placed in the Federal Register on July 25, 2012 contradicts and duplicates the former EIS noticed in 2005.

The Secretary of the Army has stated in writing that the 2005 joint EIS/EIR process is not terminated and is therefore current.

The reasoning of the resolution is as follows:

Another EIS process has been introduced by LA USACE that interferes with and contradicts the current process. The Corp has begun a new process that duplicates and reduces the scope of the 2005 Environmental Process, without first terminating it.

The two processes cannot exist concurrently, because of duplication, and the requirement for the first study to be completed. The first study has been fully funded by the U.S. Congress and the latter process has not.

The second process proposes to change the course of Ballona Creek, and to dredge and fill wetlands, prior to the completion of the first process and before the Corp can report its recommendations back to Congress.

Furthermore, the second process proposes to reintroduce tidal flow to a freshwater wetland system that was not historically connected to the to the ocean to the degree the new process implies.

The National Oceanic and Atmospheric Administration warned against this project, as it would destroy valuable upland habitat.

The U.S. Clean Water Act designates four separate Section 303(d) Impaired Waterways that are present.

- Marina del Rey
- Upper Ballona Creek
- Ballona Creek Estuary
- Ballona Wetlands

The 2012 Notice proposes to divert one Impaired Waterway into another. It is illegal to further impair a waterway that is already impaired.

The resolution reads as follows and represents the Sierra Club official stance on both of the aforesaid environmental processes.

**RESOLUTION**

*Whereas, the Airport Marina Regional Group of the Angeles Chapter Sierra Club has jurisdiction over Marina del Rey,*

*Whereas, The Club supports National Planning for Environmental Restoration, Recreational Boating, Storm Damage Reduction, and is Supportive of other purposes the Congress of the United States intended for Marina del Rey such as a youth hostel and camping facilities.*

*Whereas, The U.S. Army Corp of Engineers Environmental Impact Statement process noticed in the Federal Register in 2005 supports the same aforesaid purposes that the Sierra Club supports,*

*Therefore, be it resolved by the Airport Marina Regional Group, Angeles Chapter of Sierra Club, supports the completion of the 2005 Environmental Review process Noticed in the Federal Register to conduct a review of Marina del Rey: September 20, 2005 (Volume 70, Number 181) [Notices] [Page 55116-55117]*

END

The Sierra Club supports a full range of alternatives for the restoration, which is called for in the 2005 Notice for Environmental Impact Statement pursuant to the National Environmental Policy Act. The Sierra Club does not support a limited range of alternatives as proposed by the 2012 Notice for an Environmental Impact Statement.

Sincerely,

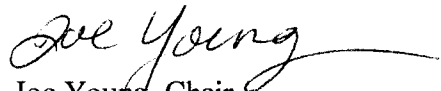

Joe Young, Chair  
Airport Marina Group  
(310) 822-9676

KATHY Knight, CONSERVATION CHAIR  
(310) 450-5961

**From:** Mary Prismon [<mailto:goldcrownking@msn.com>]

**Sent:** Saturday, August 18, 2012 9:06 AM

**To:** Lucien Plauzoles; McCormick, Donna

**Cc:** Ellen Vahan; [1and2douglas@wgn.net](mailto:1and2douglas@wgn.net); Chuck Almdale; Lillian Johnson Almdale; Elizabeth Galton; Cynthia Schotte; Jane Beseda; Charles Bragg,jr; Jean Garrett

**Subject:** RE: Ballona restoration "meeting"

Lu, As a long time member of SMBAS and its board of directors, I share your frustration for being stone-walled, particularly since you made considerable effort and sacrifice to be there for what should have been an informative and productive meeting. Let's hope fear of controversy is not going to forestall long term, productive outcomes. Perhaps you will be able to communicate more fully with the participants in a less public setting!

Mary

From: [plauzoles@me.com](mailto:plauzoles@me.com)

> Subject: Ballona restoration "meeting"

> Date: Thu, 16 Aug 2012 23:08:40 -0700

> CC: [ertvahan@aol.com](mailto:ertvahan@aol.com); [1and2douglas@wgn.net](mailto:1and2douglas@wgn.net); [chukar5@att.net](mailto:chukar5@att.net); [goldcrownking@msn.com](mailto:goldcrownking@msn.com); [lfjohnson@att.net](mailto:lfjohnson@att.net); [egalton@ucla.edu](mailto:egalton@ucla.edu); [caniswatch@verizon.net](mailto:caniswatch@verizon.net); [jane.beseda@gmail.com](mailto:jane.beseda@gmail.com); [braggjr67@verizon.net](mailto:braggjr67@verizon.net); [jeandrum2001@yahoo.com](mailto:jeandrum2001@yahoo.com)

> To: [donna.mccormick@icfi.com](mailto:donna.mccormick@icfi.com)

>

> Dear Ms. McCormick, I took time off today to attend the "scoping" meeting at the Fiji Way Edison parking lot.

> I was very surprised by the lack of solid information available from the agency and consultant teams.

> What I noticed was that all personnel present were well trained in conflict avoidance, to the expense of solid information.

> Is it because I walked into the parking area at the same time as Marcia Hanscom that I was "dodged" on every question?

>

> I actively participated in the Ballona Watershed task force 7-11 years ago. I was accustomed to rather straight, serious answers.

> When I keyed in the linked [www.ballonarestoration.org](http://www.ballonarestoration.org) address from Aug. 13th through 16th, I was not able to get ANY information.

> Are we feeding Marcia? (...who was standing in the parking lot when I drove in, gathering an audience?)

>

> Please give me some solid links that tell me what has really happened in the past 5 years at the meetings we either could not or declined to attend. What exactly are the alternatives being considered, ...or are they really not even set as alternatives as one of the SMBRC representatives vaguely said? Our only information about alternatives under consideration has been gleaned from Ballona Renaissance's newsletters.

>

> We are active, funding stakeholders in the Ballona restoration process. We are active in making Ballona relevant to the residents of the entire watershed through our educational activities with Friends of Ballona.

>

> If you refer to many of the existing documents on line and in the written record, we, as a group of approximately 1,000 active stakeholders, have a moderate record of careful examination of scientific and political data on most questions. We would like to either sustain or try to oppose Ballona restoration projects. We truly would like to have more information on the state of the Ballona restoration project before it is cast in concrete by a consultant. However, we have no idea of the "state of affairs" from this evening's meeting. It seemed to be an exercise in decision/question avoidance.

>

> I was, this evening, surprised by the "fill in an opinion card" response to any question I might pose, whether it might, in some time, be controversial or not. The information presented was not even sketchy--it was not a 10th of what was

presented on your company's/CA F and G's website!

>

> Granted, avoidance of controversy makes decision-making smoother, however, your consultancy as well as any agency owes us more!

>

> Would it be of interest for a representative of your firm to make a short presentation at one of our monthly evening meetings, starting October? We meet at the Ken Edwards Center in Santa Monica on the first Tuesday of each month, (Oct, Nov, Dec, Feb, Mar Apr May)? Please let me know with a few weeks' notice if there is any interest.

>

>

> Lucien (Lu) Plauzoles, M.S.

> Co-chair Conservation

> Santa Monica Bay Audubon Society

>

>

**Jones, Tanya**

---

**From:** April De Stefano [<mailto:april.destefano@gmail.com>]

**Sent:** Sunday, August 19, 2012 2:37 PM

**To:** McCormick, Donna

**Subject:** Ballona Wetlands

Dear Donna McCormick,

As a home owner in the Del Rey neighborhood just northeast of the Ballona wetlands, I am thrilled about efforts to restore and expand the wetlands. I and my neighbors strongly support a plan to restore as much as possible of the wetland to its most natural state, providing much-needed habitat for native flora and fauna.

Sincerely,  
April de Stefano

Los Angeles, 90066

**Jones, Tanya**

---

**From:** Barbara Yang [<mailto:Barbara.Yang@fox.com>]

**Sent:** Monday, August 20, 2012 8:58 AM

**To:** McCormick, Donna

**Subject:** Ballona project

Dear Ms. McCormick,

The Ballona Wetlands are a natural resource that need to be kept that way. I ride my bike down that path to get to the beach and it's one of the most peaceful parts of Los Angeles. The birds that hang out there are awesome and I know for a fact that local school kids go there for field trips (my friend teaches in Manhattan Beach & has taken her students there) to observe the birds and their behavior. To remove those levees to allow trash to just run into the ocean would be an ecological disaster. There is enough pollution in the ocean to allow such a thing to happen. Please leave the Wetlands alone. Enough of this city has been urbanized beyond repair.

Thank you,  
Barbara Yang



## Jones, Tanya

---

**From:** Rosie Puntillo [<mailto:rosepuntil@aol.com>]  
**Sent:** Tuesday, August 21, 2012 10:11 AM  
**To:** McCormick, Donna  
**Cc:** [rexfrankel@yahoo.com](mailto:rexfrankel@yahoo.com)  
**Subject:** Ballona wetlands in West L.A. public opinion submission

[DONNA.MCCORMICK@icfi.com](mailto:DONNA.MCCORMICK@icfi.com)  
Ballona Wetlands Restoration Project  
C/O Donna McCormick  
1 Ada, Suite 100  
Irvine, CA 92816

Dear Ms. McCormick,

I could not attend the meeting last week and I'd like to take this opportunity to share my opinion about Ballona Wetlands in West L.A.

I support saving the trails, keeping pollution out of the wetlands and supporting restoration plans that serve all of the wildlife that is in the Wetlands. I support BEEP's alternative vision plan.

Thank you,  
Rose

Rose Puntillo  
7924 Clinton St #5  
Los Angeles, CA 90048

<http://about.me/rationalrosie>

**Think before you print: save energy, ink and paper. If you must print, please print it double sided.**

-----Original Message-----

**From:** Rex Frankel <[rexfrankel@yahoo.com](mailto:rexfrankel@yahoo.com)>  
**To:** hiking-196-announce <[hiking-196-announce@meetup.com](mailto:hiking-196-announce@meetup.com)>  
**Sent:** Tue, Aug 14, 2012 12:32 pm  
**Subject:** [hiking-196] Protect our wild trails and wild areas at Ballona wetlands in West L.A.--Speak out on THURSDAY AUGUST 16TH, 4 TO 7 PM, OR WRITE AN EMAILEMAIL

WHAT'S HAPPENING: On this Thursday, August 16th is the first public hearing on the State bureaucracy's plan to massively bulldoze and forever change the Ballona wetlands nature preserve.

You can either attend the meeting or write letters until September 10th.



I have posted a page full of information and photos that give a lot more on this project here: <http://ballona-news.blogspot.com/2012/08/first-big-public-hearing-on-ballona.html>

A public scoping meeting to receive input on the scope of the DEIS/EIR will be conducted on Thursday August 16, 2012, from 4:00-7:00 p.m. at the Fiji Gateway entrance to the Ballona Wetlands (13720 Fiji Way, Marina del Rey, CA 90292, across from Fisherman's Village and Los Angeles County Department of Beaches and Harbors).

**WHAT TO DO:**

**ON THURSDAY, SUPPORT SAVING OUR TRAILS, KEEPING POLLUTION OUT OF THE WETLANDS, AND "RESTORING" THAT SERVES ALL THE WILDLIFE THAT IS THERE NOW! SUPPORT BEEP'S ALTERNATIVE VISION PLAN!**

Comments may also be submitted until September 10, 2012 to [DONNA.MCCORMICK@icfi.com](mailto:DONNA.MCCORMICK@icfi.com).

Or mailed to:

Ballona Wetlands Restoration Project

C/O Donna McCormick

1 Ada, Suite 100

Irvine, CA 92816

## **THE STATE'S PROPOSAL INCLUDES:**

--Removal of most long-used public trails

--Removal of the Ballona Creek levees and the pouring of billions of gallons of polluted street drainage into the Ballona Wetlands

--Permanent discharge of fill (dirt) within 43.5 acres of non-wetland waters of the U.S. (435,000 cubic yards) and within 65 acres of wetland waters of the U.S. (600,000 cubic yards),

--Conversion of a balanced ecosystem featuring three rare and fragile wildlife habitats into nearly entirely an arm of the ocean filled with polluted urban street drainage **PLEASE READ MY POST TO SEE OUR**

**ALTERNATIVE PROPOSAL** <http://ballona-news.blogspot.com/2012/08/first-big-public-hearing-on-ballona.html> ---Thanks for your support! Rex Frankel, hike organizer

--

This message was sent by Rex Frankel ([rexfrankel@yahoo.com](mailto:rexfrankel@yahoo.com)) from [The Los Angeles Hiking Group](#).

To learn more about Rex Frankel, visit his/her [member profile](#)

Meetup, PO Box 4668 #37895 New York, New York 10163-4668 | [support@meetup.com](mailto:support@meetup.com)



**California Cultural Resource Preservation Alliance, Inc.**

**P.O. Box 54132  
Irvine, CA 92619-4132**

**An alliance of American Indian and scientific communities working for  
the preservation of archaeological sites and other cultural resources.**

August 21, 2012

**RECEIVED**

Dr. Daniel P. Swenson  
U.S. Army Corps of Engineers  
Los Angeles District  
P.O. Box 532711  
Los Angeles, CA 90053-2325

AUG 24 2012  
B.E.T.  
REGULATORY DIVISION  
LOS ANGELES OFFICE

RE: Draft Environmental Impact Statement/Environmental Impact Report for the Proposed Ballona Wetlands Restoration Project at Ballona Creek Within the City and County of Los Angeles, CA.

Dear Dr. Swenson:

The proposed project sounds like it would be good for the environment, but it could be bad for archaeological sites unless serious consideration is give to preservation rather than excavation. As you know the Ballona area is culturally sensitive and many significant archaeological sites have been destroyed by development. Unfortunately, a well-intentioned project to restore a riparian stream resulted in the destruction of a mission period Gabrieleno cemetery.

Archaeological excavations are labor intensive and expensive and preservation almost always results in cost savings. The Waterways Experimental Station published a manual on archaeological site preservation techniques, including site burial and erosion prevention. Rather than have additional archaeological sites destroyed in the process of restoring natural resources, this can be an opportunity to both restore natural resources and protect cultural resources; after all the archaeological sites have been there as long as the wetlands. Please involve archaeologists, Native Americans, and engineers early in the planning process with the goal of preservation, rather than data recovery "mitigation". All this would take is the kind of creative planning that the Corps has been known to undertake in Arizona, Warm Springs Dam, California, and elsewhere.

Sincerely,

Patricia Martz, Ph.D.  
Professor Emeritus  
California State University, Los Angeles

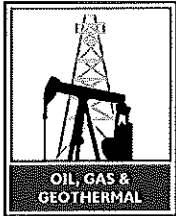

# DEPARTMENT OF CONSERVATION

## DIVISION OF OIL, GAS AND GEOTHERMAL RESOURCES

5816 Corporate Avenue • Suite 200 • CYPRESS, CALIFORNIA, 90630-4731

PHONE 714 / 816-6847 • FAX 714 / 816-6853 • WEBSITE [conservation.ca.gov](http://conservation.ca.gov)

August 24, 2012

Donna McCormick  
Ballona Wetlands Restoration Project  
1 Ada, Suite 100  
Irvine, CA 92816

Dear Ms. McCormick:

### NOTICE OF PREPARATION OF A DRAFT ENVIRONMENTAL IMPACT REPORT – SCH# 2012071090

The Department of Conservation's Division of Oil, Gas, and Geothermal Resources (Division), Cypress office, has reviewed the above referenced project. Our comments are as follows:

The proposed project is located within the administrative boundaries of the Playa Del Rey Oil Field. There are approximately 47 plugged and active wells within and/or adjacent to your proposed project. These wells are located on Division map 120 and in Division records.

The Division is mandated by Section 3106 of the Public Resources Code (PRC) to supervise the drilling, operation, maintenance, and plugging and abandonment of wells for the purpose of preventing: (1) damage to life, health, property, and natural resources; (2) damage to underground and surface waters suitable for irrigation or domestic use; (3) loss of oil, gas, or reservoir energy; and (4) damage to oil and gas deposits by infiltrating water and other causes. Furthermore, the PRC vests in the State Oil and Gas Supervisor (Supervisor) the authority to regulate the manner of drilling, operation, maintenance, and abandonment of oil and gas wells so as to conserve, protect, and prevent waste of these resources, while at the same time encouraging operators to apply viable methods for the purpose of increasing the ultimate recovery of oil and gas.

The scope and content of information that is germane to the Division's responsibility are contained in Section 3000 et seq. of the Public Resources Code (PRC), and administrative regulations under Title 14, Division 2, Chapter 4 of the California Code of Regulations.

If any structure is to be located over or in the proximity of a previously plugged and abandoned well, the well may need to be plugged to current Division specifications.

Ms. Donna McCormick  
August 24, 2012  
Page 2 of 2

Section 3208.1 of the Public Resources Code (PRC) authorizes the State Oil and Gas Supervisor (Supervisor) to order the reabandonment of any previously plugged and abandoned well when construction of any structure over or in the proximity of the well could result in a hazard.

An operator must have a bond on file with the Division before certain well operations are allowed to begin. The purpose of the bond is to secure the state against all losses, charges, and expenses incurred by it to obtain such compliance by the principal named in the bond. The operator must also designate an agent, residing in the state, to receive and accept service of all orders, notices, and processes of the Supervisor or any court of law.

Written approval from the Supervisor is required prior to changing the physical condition of any well. The operator's notice of intent (notice) to perform any well operation is reviewed on engineering and geological basis. For new wells and the altering of existing wells, approval of the proposal depends primarily on the following: protecting all subsurface hydrocarbons and fresh waters; protection of the environment; using adequate blowout prevention equipment; and utilizing approved drilling and cementing techniques.

The Division must be notified to witness or inspect all operations specified in the approval of any notice. This includes tests and inspections of blowout-prevention equipment, reservoir and freshwater protection measures, and well-plugging operations.

The Division recommends that adequate safety measures be taken by the project manager to prevent people from gaining unauthorized access to oilfield equipment. Safety shut-down devices on wells and other oilfield equipment must be considered when appropriate.

If any plugged and abandoned or unrecorded wells are damaged or uncovered during excavation or grading, remedial plugging operations may be required. If such damage or discovery occurs, the Division's Cypress district office must be contacted to obtain information on the requirements for and approval to perform remedial operations.

Sincerely,



Syndi Pompa  
Associate Oil & Gas Engineer - Facilities

CC: State Clearinghouse; P.O. Box 3044, Sacramento, CA 95812-3044  
CA Department of Fish and Game; 3883 Ruffin Road; San Diego, CA 92123

## Jones, Tanya

---

From: Walter Lamb [<mailto:walter.lamb@earthlink.net>]  
Sent: Friday, August 24, 2012 3:52 PM  
To: McCormick, Donna  
Cc: Shelley Luce  
Subject: EIS/EIR Public Comment Questions

Hi Donna -

It was nice to meet you last Thursday evening. Because this is the first time going through the EIS/EIR process for so many stakeholders, I thought it would good to ask some questions:

- Since e-mail is one of the ways to send comments, I am assuming that any format is acceptable, but I want to confirm that there is no requirement to use the official comment cards or any particular format. Is that correct?
- How do you categorize and/or tabulate comments? If numerous people make the same, or similar comments, do you aggregate them or treat them each separately? Do you give any priority to comments shared by many people over comments made by only one or two people?
- Is there any priority given to comments made earlier than those made closer to the deadline?
- Are there any length restrictions?
- Can people who have already submitted comments submit additional comments at a later date as long as it before the deadline?
- Will submitters of comments get any kind of confirmation of receipt prior to the deadline to ensure that they can resend comments that were not delivered correctly for any reason?

These are all important questions for our organization as we are interested in broadening public participation in this process so we want to make sure we have a thorough understanding of how messages will be received and processed.

Thank you for your assistance,

Walter Lamb  
President  
Ballona Wetlands Land Trust  
(310) 384-1042

**Jones, Tanya**

---

**From:** Maria Fernanda Braga [[mailto:fe\\_braga@hotmail.com](mailto:fe_braga@hotmail.com)]

**Sent:** Wednesday, August 29, 2012 11:05 PM

**To:** McCormick, Donna

**Subject:** improvements in the Ballona Wetlands

Here is my wish list:

- 1) A bike path/walkway south of Lincoln from West Jefferson Blvd to Culver Blvd into Playa del Rey.
- 2) A wider bridge expansion on Lincoln, just south of the Culver Blvd overpass.
- 3) A bike path/walkway from the bridge (mentioned above) to Fiji Way.

Thanks ;-)

Fernanda

## **Jones, Tanya**

---

**From:** Chan, Eddie [Eddie.Chan@activision.com]

**Sent:** Wednesday, August 29, 2012 11:15 AM

**To:** McCormick, Donna

**Subject:** Ballona Wetlands improvements

Hi Donna,

I wanted to chime in my opinion on the Ballona Wetlands improvements. I do think this is a critical need – the current paths are too narrow and dangerous to comfortably reach the beach from Playa Vista. It's particularly an issue given how many young families are in the community and try to routinely go bike riding to the beach. I am in agreement with the 3 areas outlined by some others for improvements. Thank you for your time.

- 1) A bike path/walkway south of Lincoln from West Jefferson Blvd to Culver Blvd into Playa del Rey.
- 2) A wider bridge expansion on Lincoln, just south of the Culver Blvd overpass.
- 3) A bike path/walkway from the bridge (mentioned above) to Fiji Way.

---

### **Eddie Chan**

Vice President, Finance & Strategy – Americas

Activision Blizzard | 3100 Ocean Park Blvd | Santa Monica, CA 90405

w. 310.496.5261 | c. 917.270.5116



## Jones, Tanya

---

**From:** Alana Getz [<mailto:alanagetz@gmail.com>]  
**Sent:** Wednesday, August 29, 2012 01:03 PM  
**To:** McCormick, Donna  
**Cc:** Michael Getz <[mgetz@calalum.com](mailto:mgetz@calalum.com)>  
**Subject:** support for walking/bike paths near Playa Vista

Hi Donna,

Julie Knap suggested we email you in regard to walking/biking paths near Playa Vista. We could not be more supportive of this idea!

We have lived in Playa Vista for five years and are always concerned when we try to get from Playa Vista to the bike path that leads to the beach/shopping center - it is very sketchy trying to ride along the skinny bike lane on Lincoln over the bridge with the cars whizzing by and now especially that we have a baby, we are extremely hesitant to take her along that stretch. We love to walk and ride our bikes and it would be WONDERFUL to be able to get to the beach and to the shopping center easily and SAFELY without getting in the car.

Thank you so much for your help to make this happen, and if you need any assistance, we'd be on board!

Thanks,

Alana and Michael Getz

Tempo residents, Playa Vista

**Jones, Tanya**

---

**From:** Barsam Kasravi [barsamk@gmail.com]

**Sent:** Wednesday, August 29, 2012 11:18 AM

**To:** McCormick, Donna

**Subject:** Wetlands

I would like to join the conversation to advocate for a wider path and bike path to the Ballona Wetlands on Lincon Blvd. Currently getting to Playa Del Rey under the Lincoln Bridge is very dangerous with kids.

Thanks,  
barsam kasravi, md

**Jones, Tanya**

---

**From:** Julie Thomas Knap [<mailto:jtknap@gmail.com>]

**Sent:** Wednesday, August 29, 2012 01:05 AM

**To:** McCormick, Donna

**Subject:** Ballona Wetlands Improvements

Hi Donna,

I am a Playa Vista resident and would love to see the following user-friendly improvements to the Ballona Wetlands.

1) A bike path/walkway south of Lincoln from West Jefferson Blvd to Culver Blvd into Playa del Rey.

2) A wider bridge expansion on Lincoln, just south of the Culver Blvd overpass.

3) A bike path/walkway from the bridge (mentioned above) to Fiji Way.

Despite our community just being one mile from the beach, we are in many ways landlocked because the pedestrian/bike paths are either non-existent and/or unsafely narrow. If there is anything I can do to help support this cause, please do not hesitate to let me know. I am a member of the Playa Vista Mom's Group (266 Members) and the Friends of Playa Vista School (399 Members).

Thank you,

Julie-

Julie Thomas Knap

Strategic Partnerships & Promotions

[jtknap@gmail.com](mailto:jtknap@gmail.com)

P: 310-804-0822

F: 310-818-5535

**Jones, Tanya**

---

**From:** Tanya Leeloy [tanya.leeloy@gmail.com]

**Sent:** Wednesday, August 29, 2012 12:43 PM

**To:** McCormick, Donna

**Subject:** Our Playa Vista Community

Hi Donna,

I was told that you could be of assistance regarding improving upon our Playa Vista/Ballona Wetlands area.

We as a community have all been trying to look into who to go to for this so hopefully this is the right place!

Our wish list:

- 1) A bike path/walkway south of Lincoln from West Jefferson Blvd to Culver Blvd into Playa del Rey.
- 2) A wider bridge expansion on Lincoln, just south of the Culver Blvd overpass.
- 3) A bike path/walkway from the bridge (mentioned above) to Fiji Way.

Despite our community just being one mile from the beach, we are in many ways landlocked because the pedestrian/bike paths are either non-existent and/or unsafely narrow.

Thanks so much!

We love our community and have attempted to ride our bike to the beach with our toddler in tow and it just too unsafe.

Warmly,

Tanya & Todd, parents to a 4 year old and one on the way.

**Jones, Tanya**

---

**From:** Lohman, Kevin G. [<mailto:KLohman@ReedSmith.com>]

**Sent:** Wednesday, August 29, 2012 11:07 AM

**To:** McCormick, Donna

**Subject:** Ballona Wetlands Improvements

Below please find my suggested improvements for the Ballona Wetlands. Thank you for your consideration.

- 1) A bike path/walkway south of Lincoln from West Jefferson Blvd to Culver Blvd into Playa del Rey.
- 2) A wider bridge expansion on Lincoln, just south of the Culver Blvd overpass.
- 3) A bike path/walkway from the bridge (mentioned above) to Fiji Way.

Despite our community just being one mile from the beach, we are in many ways landlocked because the pedestrian/bike paths are either non-existent and/or unsafely narrow.

**Kevin G. Lohman**

213.457.8040

[klohman@reedsmith.com](mailto:klohman@reedsmith.com)

**Reed Smith LLP**

355 South Grand Avenue

Suite 2900

Los Angeles, CA 90071

213.457.8040

Fax 213.457.8080

\* \* \*

This E-mail, along with any attachments, is considered confidential and may well be legally privileged. If you have received it in error, you are on notice of its status. Please notify us immediately by reply e-mail and then delete this message from your system. Please do not copy it or use it for any purposes, or disclose its contents to any other person. Thank you for your cooperation.

\* \* \*

To ensure compliance with Treasury Department regulations, we inform you that, unless otherwise indicated in writing, any U.S. Federal tax advice contained in this communication (including any attachments) is not intended or written to be used, and cannot be used, for the purpose of (1) avoiding penalties under the Internal Revenue Code or applicable state and local provisions or (2) promoting, marketing or recommending to another party any tax-related matters addressed herein.

Disclaimer Version RS.US.20.10.00

**Jones, Tanya**

---

**From:** Ulrik Knap [<mailto:huknap@gmail.com>]

**Sent:** Wednesday, August 29, 2012 01:45 AM

**To:** McCormick, Donna

**Subject:** Playa vista.

Hi Donna,

I am a Playa Vista resident and would love to see the following user-friendly improvements to the Ballona Wetlands.

- 1) A bike path/walkway south of Lincoln from West Jefferson Blvd to Culver Blvd into Playa del Rey.
- 2) A wider bridge expansion on Lincoln, just south of the Culver Blvd overpass.
- 3) A bike path/walkway from the bridge (mentioned above) to Fiji Way.

Despite our community just being one mile from the beach, we are in many ways landlocked because the pedestrian/bike paths are either non-existent and/or unsafely narrow.

Thank you,

Ulrik Knap

[5700 Seawalk Drive, No. 6](#)

[Playa Vista, CA 90094](#)

H. Ulrik Knap

+1.310.436.4888

Sent from my iPhone

**Jones, Tanya**

---

**From:** Nikol Lohman [nikkizbaby@aol.com]  
**Sent:** Tuesday, September 04, 2012 7:54 AM  
**To:** McCormick, Donna  
**Subject:** Ballona Wetlands

Dear Donna,

Here is my wish list for improvements on the Ballona Wetlands:

- 1) A bike path/walkway south of Lincoln from West Jefferson Blvd to Culver Blvd into Playa del Rey.
- 2) A wider bridge expansion on Lincoln, just south of the Culver Blvd overpass.
- 3) A bike path/walkway from the bridge (mentioned above) to Fiji Way.

Despite our community just being one mile from the beach, we are in many ways landlocked because the pedestrian/bike paths are either non-existent and/or unsafely narrow.

Thank you,  
Nikol Lohman

**Jones, Tanya**

---

From: Liesbeth Maggiotto [<mailto:liesvdvelde26@yahoo.com>]  
Sent: Tuesday, September 04, 2012 11:19 PM  
To: McCormick, Donna  
Subject: Ballona wetlands

Hi Donna,

I live in playa vista with my husband and three kids. I grew up in the Netherlands and LOVE biking, walking and nature. It has been my dream to be able to bike everywhere with my kids however it has been very unsafe to bike out of playa vista to anywhere with my 2,6 and 8 year old. Particular a wider bridge expansion on Lincoln just south of the culver blvd overpass. But also bike paths on Lincoln towards the marina and Jefferson/ culver towards playa del Rey would be much appreciated.

Thank you so much for your attention to this matter!  
Liesbeth Maggiotto, MD  
Assistant professor in pediatrics

Sent from my iPad



**Jones, Tanya**

---

**From:** Erin Mays [erinmarielmays@gmail.com]  
**Sent:** Tuesday, September 04, 2012 8:49 AM  
**To:** McCormick, Donna  
**Subject:** Improvements to Ballona Wetlands

Hi Donna,

I live in Playa Vista. Here is my wish-list for improvements around the Ballona Wetlands. I know you have heard these before, but I feel they are important enough to repeat.

- 1) A bike path/walkway south of Lincoln from West Jefferson Blvd to Culver Blvd into Playa del Rey.
- 2) A wider bridge expansion on Lincoln, just south of the Culver Blvd overpass.
- 3) A bike path/walkway from the bridge (mentioned above) to Fiji Way.

I really feel that we are so close to the beach, but there is no way to get there besides car/bus. We have bikes, strollers, and other gear that we love riding to the beach or the Marina but it's dangerous and barely accessible, especially with our 10 month old son.

Thank you!

Erin Mays

**Jones, Tanya**

---

**From:** Tanya Lindsley [<mailto:marathoner547@gmail.com>]

**Sent:** Sunday, September 09, 2012 7:30 PM

**To:** McCormick, Donna

**Subject:** Ballona Wetlands Restoration Project

Putting in my 2 cents - I support BEEP's Alternative Ballona Plan.

Thank you,  
Tanya Lindsley  
Resident of Mar Vista, A

--

*If you're looking for a happy ending and can't find one ... find a new beginning instead.*

From: Cruz, Ruben [<mailto:RCRUZ@dpw.lacounty.gov>]  
Sent: Monday, September 10, 2012 5:14 PM  
To: Yanez, Jarrett; Swenson, Daniel P SPL  
Cc: Ibrahim, Amir  
Subject: RE: Ballona Wetlands Restoration- Notice of Intent to Prepare a Draft EIS Comments

September 10, 2012

Dr. Daniel P. Swenson  
U.S. Army Corps of Engineers  
Los Angeles District  
P.O. Box 532711  
Los Angeles, CA 90053-2325

Dear Dr. Swenson:

Notice of Intent to Prepare  
Draft Environmental Impact Statement (EIS) Ballona wetlands restoration

Thank you for the opportunity to review the Notice of Intent to Prepare a Draft EIS for the Ballona Wetlands Restoration project. The project is intended to return the daily ebb and flow of tidal waters, maintain freshwater circulation, and augment the physical and biological functions and services in the project area. The 600-acre Ballona Wetlands Ecological Reserve project area is located in the western portion of the City of Los Angeles, partially within unincorporated Los Angeles County, south of Marina Del Rey and north of Playa Del Rey.

The following comments are for your consideration and relate to the environmental document only:

Hazards - Flood/Water Quality

1. The area of the proposed project contains facilities operated and maintained by the Los Angeles County Flood Control District (LACFCD). We request that future maintenance activities needed for the proposed improvements, such as inspection, repair, clearing vegetation, sediment and debris removal and other maintenance related activities, be included in the CEQA document and all regulatory permits.
  
2. Los Angeles County Department of Public Works/LACFCD shall not be responsible for any mitigation requirements that may result from impacts associated with LACFCD's future maintenance activities of the improvements.

If you have any questions regarding the flood/water quality comments, please contact Stephen Lipka at (562) 861-0316 or [slipka@dpw.lacounty.gov](mailto:slipka@dpw.lacounty.gov) <<mailto:slipka@dpw.lacounty.gov>> .

If you have any other questions or require additional information, please contact Ruben Cruz at (626) 458-4921 or [rcruz@dpw.lacounty.gov](mailto:rcruz@dpw.lacounty.gov) <<mailto:jwan@dpw.lacounty.gov>> .

Ruben Cruz, P.E.  
CEQA, CUP, Ordinance Review Unit  
Land Development Division  
(626) 458-4910  
[rcruz@dpw.lacounty.gov](mailto:rcruz@dpw.lacounty.gov) <<mailto:jyanez@dpw.lacounty.gov>>

CONFIDENTIALITY NOTICE: This email message, including any attachments, from the Department of Public Works is intended for the official and confidential use of the recipients to whom it is addressed. It contains information that may be confidential, privileged, attorney work product, or otherwise exempted from disclosure under applicable law. If you have received this message in error, be advised that any review, disclosure, use, dissemination, distribution, or reproduction of this message or its contents is strictly prohibited. Please notify the sender of this email immediately by reply email that you have received this message in error, and immediately destroy this message, including any attachments. Thank you in advance for your cooperation.

Classification: UNCLASSIFIED  
Caveats: NONE

**Jones, Tanya**

---

**From:** Beverly Moore [<mailto:BMoore@visitmarinadelrey.com>]

**Sent:** Monday, September 10, 2012 3:10 PM

**To:** McCormick, Donna

**Subject:** Ballona Wetlands Restoration Project

Enclosed please find a letter regarding the Ballona Wetlands Restoration Project from the Marina del Rey Convention & Visitors Bureau.

**Bev Moore** | Executive Director | Marina del Rey Convention & Visitors Bureau

[bmoore@VisitMarinaDelRey.com](mailto:bmoore@VisitMarinaDelRey.com)

310-306-9900 Ext 102

[VisitMarinaDelRey.com](http://VisitMarinaDelRey.com)



Marina del Rey

*Coastal Warmth. L.A. Cool*



**MARINA DEL REY**  
CONVENTION AND VISITORS BUREAU

4551 Glencoe Ave., #260 Marina del Rey CA 90292  
T 310 306 9900 F 310 306 6605 VisitMarinaDelRey.com

September 10, 2012

Ballona Wetlands Restoration Project  
c/o Donna McCormick  
1 Ada, Suite 100  
Irvine, CA 92816

Dear Ms. McCormick:

Thank you for the opportunity to share insights and viewpoints on the restoration of Ballona Wetlands.

As you plan for the wetlands renewal, we hope that you will ensure that free and public access is made available throughout the area. We'd like to especially recommend that public access be created from Fiji Way in Marina del Rey so that residents, students and visitors interested in learning more about wetlands and conservation can more easily visit the wetlands from the Marina side of the wetlands.

Representing the travel and tourism community in Marina del Rey, we treasure this special area and the opportunity we have to restore this great natural asset along our coastline for the protection of the wetlands and the for the enjoyment and education of the public.

Sincerely,

*Beverly S Moore*

Beverly S Moore  
Executive Director

## Jones, Tanya

---

**From:** Liisa Bishop [\[mailto:liisa@me.com\]](mailto:liisa@me.com)  
**Sent:** Friday, September 21, 2012 12:04 AM  
**To:** McCormick, Donna  
**Subject:** Ballona Wetlands

Hello Donna,

I would like to put my name down as also wanting the following improvements to the Ballona Wetlands area:

- 1) A bike path/walkway south of Lincoln from West Jefferson Blvd to Culver Blvd into Playa del Rey.
- 2) A wider bridge expansion on Lincoln, just south of the Culver Blvd overpass.
- 3) A bike path/walkway from the bridge (mentioned above) to Fiji Way.

Despite our community just being one mile from the beach, we are in many ways landlocked because the pedestrian/bike paths are either non-existent and/or unsafely narrow.

Thank you,

Liisa Bishop



# Ballona Wetlands Restoration Project

Advancing ecosystem health. Connecting communities with nature.

## Comment Card

Name: BRUCE SCHELDEN

Email: (optional) \_\_\_\_\_

Add me to the mailing list (please provide email or mailing address): \_\_\_\_\_

Comments/Issues: (Use additional sheets if necessary)

I AM IN FAVOR OF A DESIGN OPTION THAT REMOVES THE LEVEES AND THE CONCRETE FROM THE WESTERN END OF BALLONA CREEKS. IT SHOULD PROVIDE FOR SIGNIFICANT TIDAL FLOW IN THE AREAS NOT CONSTRAINED BY PRIVATE PROPERTY.

THIS RESTORATION PLAN WILL REQUIRE BULLDOZERS, NOT SHOVELS.

**Submit written comments to:**

Mail: Ballona Wetlands Restoration Project  
C/O Donna McCormick  
1 Ada, Suite 100  
Irvine, CA 92816

Email: [Donna.McCormick@icfi.com](mailto:Donna.McCormick@icfi.com)

***\*\*All comments submitted will become part of the Public Record***



Tape Here  
Do Not  
Staple

Fold Here



*Bruce Schelden*  
8128 Manitoba St  
Playa Del Rey CA 90293

LOS ANGELES CA 900

13 SEP 2012 PM 6 T

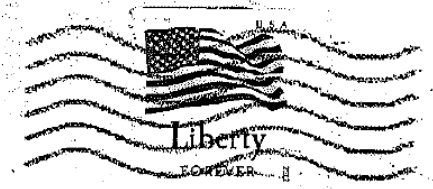

**Ballona Wetlands Restoration Project**  
**C/O Donna McCormick**  
**1 Ada, Suite 100**  
**Irvine, CA 92816**

5261 0303 A-249

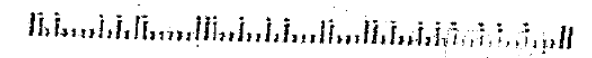

**Jones, Tanya**

---

**From:** Lewis Weinfeld [<mailto:lweinfeld@gmail.com>]

**Sent:** Wednesday, September 26, 2012 2:48 PM

**To:** McCormick, Donna

**Subject:** Nature at its best

I would love to have 600 acres of flourishing nature reserve and miles of walking and hiking trails immediately adjacent to Playa Vista, so my family can enjoy the beauty of earth.

--

Lew Weinfeld

Have a great day

## Jones, Tanya

---

-----Original Message-----

From: Alice E Goldstein [<mailto:ibrake4roses@aol.com>]

Sent: Thursday, October 04, 2012 11:52 AM

To: McCormick, Donna

Subject: Ballona Creek.

Dear Donna,

Thank you so much for all you do in preserving this special place. I walk with my dog there several times a week because the energy is very calming there and you never know what you'll see there as far as birdlife or otherwise.

This has always been a special place for wildlife and I agree it should not be tampered with by the state agencies in their so called "improvement".

If you are counting how many people are opposed to the "improvement", please consider me.

I would also like to volunteer to help out at the wetlands if needed.

Thank you again,

Sincerely,

Alice E. Goldstein

Cel. 310 2669441

Due to a prior commitment I am unable to attend the meeting. I only got the email yesterday pm. from my iPhone

David Lawhead/Terri Steward  
California Department of Fish & Game  
3883 Ruffin Road  
San Diego, CA 92123

Allen Frankel  
1466 Paseo De Oro  
Pacific Palisades, CA 90272

October 8, 2012

Dear Mr. Lawhead & Mrs. Stewart:

As a Sierra Club member who loves to hike and experience nature, there needs to be a true restoration of the Ballona Wet Lands that retains the natural features over 100 years old and that preserves rare and endangers animals and plants. For this to occur, the land must close and open according to the ocean tide cycles of nature to preserve species that require fresh water. This will save about 300 million dollars per year in silt removal -- very, very expensive operation. This money can be put into constructive wetland conservation.

Again, government and private enterprise can create a win-win-win with ecology.

Appreciate your support.

Most sincerely,



Allen Frankel

**Jones, Tanya**

---

**From:** Almstedt, Hawley [<mailto:Hawley.Almstedt@lmu.edu>]  
**Sent:** Saturday, October 13, 2012 5:32 PM  
**To:** McCormick, Donna  
**Subject:** Wetlands restoration

Hello Donna,

I learned about the upcoming Ballona Wetlands Restoration Project from a neighbor in Playa Vista. As a professor at LMU, I have heard for some time that the wetlands were to be restored and I am excited to hear that things are getting started. As an exercise physiology, a researcher in the health sciences, and a resident of Playa Vista I would like to promote safe ways to be physically active in my immediate community. Is it possible for the wetland restoration to include a walking or bike path that would connect Playa del Rey to the fresh water marsh? I would love for everyone in our community to be able to safely walk or bike to the beach without being in danger from traffic. Improving the health of our citizens includes considering how our community is planned and built. Restoration of the wetlands provides us an opportunity to make improvements that can have vast future benefits for the health of the environment and our bodies. Please let me know how I can help. Thank you.

Hawley C. Almstedt, Ph.D., R.D.  
Associate Professor  
Department of Health and Human Sciences  
Loyola Marymount University  
1 LMU Drive MS 8160, North Hall 208 | Los Angeles, CA 90045 | (310) 338-1925 Office | (310) 338-5317 Fax



For more information, visit: <http://bellarmine.lmu.edu/thebellarmineforum/>

**Jones, Tanya**

---

**From:** [rkornarens@verizon.net](mailto:rkornarens@verizon.net) [<mailto:rkornarens@verizon.net>]

**Sent:** Sunday, October 14, 2012 5:33 PM

**To:** McCormick, Donna

**Subject:** Ballona Wetlands Restoration Project

Dear Ms. McCormick,

There is a strip of vacant land between the access road to the 90 freeway and a group of townhouses that **abuts Area C**, which you plan to restore-APN 4224-014-013. A map from the County of Los Angeles Assessor's Office shows this parcel as WETLANDS, though it is zoned "RD", Restricted Density Multiple Dwelling Zone.

This land is currently owned Trask Properties that also own a Toyota dealership. They wish to use the area as a parking lot for their overflow of cars. They will need a variance to change the zoning for a parking lot. A permit has not yet been applied for.

Since the only ingress and egress to the property is on Mindanao Way, the fire department may not grant the variance. The previous owners were denied a variance.

I would like the State of California, that owns Area C to purchase this land and make it part of the Ballona Wetlands Project. I am very happy with your current plans and have no other suggestions.

My only concern is to keep the land its natural state. We have lost enough wetlands already. No, I do not wish to be on your mailing list.

Sincerely,  
Rosemarie Kornarens



P.O. Box 931057  
Los Angeles, California 90093-1057

October 15, 2012

Dr. Daniel P. Swenson  
U.S. Army Corps of Engineers  
Los Angeles District  
P.O. Box 532711  
Los Angeles, CA 90053-2325

Dear Dr. Swenson:

In response to the Notice of Intent to Prepare Environmental Impact Statement/Environmental Impact Report for the Proposed Ballona Wetlands Restoration Project please find attached a letter from the Los Angeles Audubon Society to Dr. Shelley Luce dated May 15, 2012, which contains our comments on the proposed project.

Yours sincerely,

A handwritten signature in blue ink that reads "Travis Longcore". The signature is fluid and cursive, with the first name being more prominent.

Travis Longcore, Ph.D.  
President



P.O. Box 931057  
Los Angeles, California 90093-1057

May 15, 2012

Shelley Luce, D.Env.  
Executive Director  
Santa Monica Bay Restoration Commission  
Pereira Annex MS:8160  
1 LMU Drive, Loyola Marymount University  
Los Angeles, CA 90045

Dear Dr. Luce:

Los Angeles Audubon is a California non-profit 501(c)(3) corporation established in 1910. The mission of Los Angeles Audubon is to promote the enjoyment and protection of birds and other wildlife through recreation, education, conservation and restoration. We have over 3,500 members and supporters, most of whom live in Los Angeles. I am sending this letter on behalf of the Board of Directors of Los Angeles Audubon, which approved it unanimously at its April 5, 2012 meeting.

Los Angeles Audubon has a long history of involvement with the Ballona Wetlands. Our members have birded here for over 100 years, since it was known as the Ballona Swamp. In the 1990s, we and our partners developed and now continue to run an elementary school education program in the wetlands that reaches over 2,000 children per year. We have run free, public field trips to the wetlands and surrounding areas for decades and have included this area as part of the Los Angeles Christmas Bird Count for decades as well.

The Ballona Wetlands have been identified as an Important Bird Area by the National Audubon Society on the basis of the resources currently at the site. A portion of the description of the Ballona IBA is as follows:

Belding's Savannah Sparrow maintains a small but apparently viable population in the salt marsh, among the most northerly in the world.

The area's habitats include coastal (largely-muted) saltmarsh with salt pans (all of which is now owned by the state and has been designated an Ecological Reserve), freshwater marsh (including a new 26-acre constructed freshwater wetland/water treatment lagoon and 25 acre riparian corridor along a re-



constructed tributary connecting to the freshwater marsh), dune remnants, grassland, riparian thickets, and along the south edge, coastal sage and coastal bluff scrub.<sup>1</sup>

Based on the importance of this site, our long history of involvement, our current organizational activities, and the interests of our members, we want to express some concerns about the wetland creation plans that have emerged from the working group that your organization leads on behalf of the State of California.

Our review of the current conceptual plans and phasing documents available at [www.ballonarestoration.org](http://www.ballonarestoration.org) prompts the following comments.

1. The plans appear to remove all existing habitat for the State-endangered Belding's Savannah Sparrow. Given the long history of occupancy of the site at these locations by this species, it does not seem wise to remove all existing habitat. Although it is conceivable that the phased implementation of the plan would result in additional pickleweed habitat where the sparrow might move, we have serious concerns about the uncertainties inherent in this approach. What steps in your plan allow for this species to remain on site during construction? What is the phasing and timeframe being considered to accommodate Belding's Savannah Sparrow? We have similar concerns about the particular habitat requirements and distributions of other sensitive bird species and their fate during and after project implementation.
2. The plan proposes removal of existing native habitats that have been restored with thousands of hours of community effort and with significant success. In particular, community members have worked to restore the dune remnant at the western end of the property over many years, and have been rewarded by the recent colonization of the site by endangered El Segundo blue butterflies. The most recent plans for the Ballona project show this site covered by a berm.
3. Other existing natural features that have a long history on the landscape would be removed in the plans. Examples of this include the natural freshwater seep that is marked by an old cottonwood tree near the dunes and the large salt panne that has been present and stable on the site for over 120 years.<sup>2</sup> The salt panne is used by thousands of migrating birds each year and is an essential component of the Ballona wetlands ecosystem. The proposed removal of existing natural features that have been stable on the landscape for generations greatly concerns us.

Any management of the site to enhance biological resource values should recognize that the current habitats at Ballona wetlands do provide significant bird habitat of many kinds and represent one of the few places where the public can observe these species in the Los Angeles

---

<sup>1</sup> National Audubon Society 2012. Important Bird Areas in the U.S. Available at <http://www.audubon.org/bird/iba>. Accessed 09 March 2012

<sup>2</sup> Dark, S., E. D. Stein, D. Bram, J. Osuna, J. Monteferrante, T. Longcore, R. Grossinger, and E. Beller. 2011. Historical ecology of the Ballona Creek watershed. Southern California Coastal Water Research Project. Technical Report #671.

basin. We fear that these values have not been adequately incorporated into the goal of better managing the resources.

We look forward to meeting with you about the proposed wetland creation project and how our concerns might be addressed as the planning process moves forward.

I can be reached at [travislongcore@laaudubon.org](mailto:travislongcore@laaudubon.org) if you would be able to discuss these concerns with us.

Yours sincerely,

A handwritten signature in black ink that reads "Travis Longcore". The signature is fluid and cursive, with a long horizontal stroke extending to the right.

Travis Longcore, Ph.D.  
President

**Jones, Tanya**

---

**From:** Sandra Glass [<mailto:1sanglass@gmail.com>]  
**Sent:** Wednesday, October 17, 2012 4:31 PM  
**To:** McCormick, Donna  
**Subject:** Fwd: Ballona Wetlands Restoration Project

Dear Donna,

I am so sorry. I pressed send before I completed my email to you. As I was saying, I live on Playa Vista, behind the old post office; which is presently under construction of 500 Units. I do not know if that is true, but is hearsay. Two months ago, when they started digging and clearing the Post Office area, we have been living with constant jolts and shaking, which starts at 8:00 a.m. for the entire day. At the beginning I thought these were earthquakes; but they weren't. I fear that this additional construction behind us could be a dangerous threat to this community. Just from a layman's opinion, I don't think these condo's could stand this additional construction going on. In fact, with all the methane gas and oil, which the developers tried to secure, I feel we are all in danger, especially, since there is a lot of earth movement, all day long. This can not be a good thing. I'm hoping the city engineers know what they are doing. Anyway, I'm thinking of my course of action. Again, the constant earth movement from this additional construction behind us, could threaten our health or existence. I hope this bit of information, can help you in some ways. And hopefully, someone will look into this. Good Luck with you Quest. Best, Sandra (Please don't publish )

Begin forwarded message:

**From:** Sandra Glass <[1sanglass@gmail.com](mailto:1sanglass@gmail.com)>  
**Subject:** Ballona Wetlands Restoration Project  
**Date:** October 17, 2012 3:54:03 PM PDT  
**To:** [DONNA.MCCORMICK@icfi.com](mailto:DONNA.MCCORMICK@icfi.com)

Dear Donna, I am very sorry about your last case. I have not been following any of the environmental challenges you have faced recently; but I may have just the leverage you need with those officials in command. I am living in Playa Vista, the place you tried so hard to save.

JM

RECEIVED

OCT 23 2012

October 18 2012  
LABORATORY DIVISION  
LOS ANGELES OFFICE

P.S. I just watched  
the "Big Unruly"  
documentary for the  
2nd time.

Dear Mr. Swenson,

I am very involved  
in the future of our  
precious Ballona Wetlands.

As I write there are so  
many animals, reptiles &  
birds that are living and  
thriving in the wetlands.  
Many of these animals are  
nest burrowers so I am  
very concerned and against  
the so called "Restoration" using  
bulldozers and heavy equipment  
on this fragile land.

Are there, and there should be,  
restoration plans that do not  
destroy habitats in order to  
rebuild them with "pork"  
money from Congress etc.?

Thank you,  
Louise Steiner

My address  
1659 Ocean Front  
Santa Monica CA 90401

A-260

October 19, 2012

Dear David Lawhead and Terri Stewart,  
I am a 36 year resident and  
lover of our precious Ballona  
Wetlands.

So few wetlands are left and  
what is left must be preserved  
in the most "natural" way possible.  
The proposed plans for the so called  
"restoration" seems more to  
destroy than spend millions of dollars  
to rebuild. The use of giant  
bulldozers and heavy equipment  
would endanger any burrowing  
animals or birds habitats etc.

The remaining wetlands are  
teeming with a myriad of animals,  
mammals, reptiles and birds.

Are there any restoration plans  
being considered that would avoid  
massive bulldozing and using  
less invasive measures?

After hearing a lecture of learned  
individuals. The current plan of  
erecting huge man-made  
beams etc seems only

protecting the "Playa Vista" community  
against flooding, with no regard  
to the existing wildlife and  
habitat.

There needs to be alternative  
same + natural restoration  
plans offered. Will there be?

Thank you,  
Louise Steiner

**Jones, Tanya**

---

-----Original Message-----

From: Swenson, Daniel P SPL [<mailto:Daniel.P.Swenson@usace.army.mil>]  
Sent: Monday, October 22, 2012 9:40 AM  
To: [douglaspfay@aol.com](mailto:douglaspfay@aol.com)  
Cc: Diana Hurlbert; [DLawhead@dfg.ca.gov](mailto:DLawhead@dfg.ca.gov)  
Subject: RE: Proposed Ballona Wetlands Restoration Project questions (UNCLASSIFIED)

Classification: UNCLASSIFIED  
Caveats: NONE

Mr. Fay,

I have responded to your questions below (see \*\*\*).

sincerely,

Daniel P. Swenson, D.Env.  
Chief, LA & San Bernardino Counties Section U.S. Army Corps of Engineers  
Attn: Regulatory Division  
915 Wilshire Blvd.  
Los Angeles, CA 90017

213-452-3414  
213-452-4196 fax  
<http://www.spl.usace.army.mil/Missions/Regulatory.aspx>

Assist us in better serving you!  
You are invited to complete our customer survey, located at the following link: <http://per2.nwp.usace.army.mil/survey.html>

Note: If the link is not active, copy and paste it into your internet browser.

-----Original Message-----

From: [douglaspfay@aol.com](mailto:douglaspfay@aol.com) [<mailto:douglaspfay@aol.com>]  
Sent: Saturday, October 20, 2012 8:17 PM  
To: Swenson, Daniel P SPL; [DLawhead@dfg.ca.gov](mailto:DLawhead@dfg.ca.gov)  
Subject: Proposed Ballona Wetlands Restoration Project questions

Dear Dr. Swenson & Mr. Lawhead,

It is my understanding that the Comment Period on the proposed BWRP ends October 23, 2012.

At what time of day on October 23, 2012 does the Comment Period close?

\*\*\*Any comments received at any time on the 23rd would be considered.

Can I send comments to you electronically by email before the deadline?

\*\*\*Electronic or regular mail submittal is fine.

Will postmarked by October 23, 2012 submissions by postal mail be accepted?

\*\*\*Yes.

Will all of my questions asked at this time (NOI) be answered and mailed to me prior to the Draft EIS/EIR being prepared?

\*\*\*Speaking for the federal process, all scoping comments will be included in the draft EIS/EIR; however, there is no requirement to respond to scoping comments directly or to mail any responses to commenters.

Will acknowledgement of my comments and proposed alternatives be mailed to me prior to the Draft EIS/EIR being prepared?

\*\*\*Not as part of the federal process.

Will a complete list of all letters, comments and questions and your replies be posted and available online prior to the Draft EIS/EIR being prepared?

\*\*\*Not as part of the federal process.

I'm somewhat familiar with CEQA, but not the NOI process. If you could briefly elaborate on the format of comments on the NOI that is best for you, I would appreciate your reply ASAP by Monday, October 22, as the imposed deadline is near.

\*\*\*There is no preferred format I am aware of, although in general, I would suggest submitting concise comments focused on the issues of concern and any specific, desired actions or outcomes.

Respectfully submitted,

Douglas Fay  
644 Ashland Ave Apt A  
Santa Monica, CA 90405  
Tele: 310 437-0765  
email: [douglasfay@aol.com](mailto:douglasfay@aol.com)

Classification: UNCLASSIFIED  
Caveats: NONE

## Jones, Tanya

---

**To:** McCormick, Donna  
**Subject:** RE: Contact form submission from sue sass

**From:** sue sass [<mailto:nobody@santamonicabay.org>]  
**Sent:** Saturday, October 20, 2012 11:44 PM  
**To:** Charles Piechowski  
**Subject:** Contact form submission from sue sass

Submission from 'RSVP Piechowski' form:

**Name :**  
sue sass

**Email :**  
[ssass60@Yahoo.com](mailto:ssass60@Yahoo.com)

**Message :**

Unfortunately, there are many birds that are no seen in the Ballona area. Namely, the red-winged black birds, the singing meadowlarks, and the occasional Kingfisher along Culver Boulevard. Additionally, the bullfrogs, and other amphibians that used to be heard croaking along Jefferson Boulevard near Lincoln in the evening, are also missing since the development of Playa Vista started in the 1990's... The grasslands & meadows are gone! as well as the natural waters that used to flow from Sepulveda Boulevard/Centinela westward along Jefferson....

After reviewing the survey charts and comments, and being able to recall how much open land has been eliminated due to high density construction in our neighborhoods bordering Slauson, Centinela, Sepulveda, and Jefferson, it's no wonder that many species have disappeared that used to inhabit these areas.

I am concerned about the \"restructuring\" of the remaining Ballona Wetlands.

As mentioned many times, this area should be protected from \"good intensions in cement\"... and destroying the natural sands, clay, loam, that provide a natural filtering system and a native habitat.

I do hope that a thorough survey and collection of native plants is conducted before any large scale restoration plans are initiated.

I do not feel that a proper and complete EPA study and accurate survey was conducted prior to allowing the massive Playa Vista to be developed- which has resulted in eliminating much of and altering the Ballona Wetlands habitat areas.

**Submit :**  
Submit

---

**IP address of the submitter:**  
76.89.158.57



David Lawhead/Teri Stewart  
California Department of Fish and Game  
3883 Ruffin Road  
San Diego, CA 92123

Re: NOI Ballona Wetlands Restoration 10/21/2012

I have spent the last 20 years fighting to preserve as much of the wetlands as possible and now I have read the following: Wetlands Explained by William M. Lewis, In Search of Swampland by Ralph W. Tiner, Wetlands by Peter D. Moore, and Wetlands by Max Finalyson and Michael Moser to try to better understand wetlands and to look at the alternatives with a more educated perspective. I have recently begun attending the Santa Monica Bay Commission Meetings, I attended one community event and I attended the scoping venue and I have many unanswered questions.

When you refer to "the restoration project" or simply "the project", are you referring to a specific project alternative, or more generically to the process of selecting and then implementing an alternative? Many public statements seem to indicate the former and others seem to indicate that a final decision on which alternative to pursue has not yet been made.

Why must we proceed with the most expensive and most risky solution straight away rather than first seeing what can be achieved with a lower cost and lower risk alternative?

Won't the highly polluted water from the Ballona Creek harm the Ballona Wetlands ecosystem if the levees are breached and that water is allowed to flow directly into the ecosystem?

What plan is in place to clean up the stream before it reaches the wetlands, and what is the timeline for such a plan to be implemented?

Won't this project relieve the state government and local city governments of the pressure to do more to clean the water in the Ballona Creek further upstream?

You have compiled a baseline monitoring report for the current biological diversity of this ecosystem. Have you made any projections as to how different species of animals and plants are likely to be affected by the various project alternatives? For instance, there are a number of birds in the baseline report that favor upland habitat, and upland habitat would decline significantly under the favored project alternative. Would not those species therefore be expected to decline if those alternatives are implemented? Are there charts that can help us better understand how each species is expected to fare?

The assessment of the various project alternatives seems entirely based on the goal of increasing estuarine habitat. How was that goal established and how was the benefit of increased estuarine habitat balanced against the loss of upland habitat and other types of habitat?

What will be the increase in distance in the Ballona Creek bike trail (from beginning of the new route to end of the new route) as a result of the proposed rerouting? Will there be portions of the creek that are no longer accessible from the bike trail?

Is it possible that the project will ultimately be funded by mitigation dollars from another development project elsewhere in the area that will have a negative impact on the overall health of the area's ecosystems? In other words, could accepting funds for this project pave the way for other wetlands ecosystems to be compromised?

SMBRC recently received \$6.25 million from the California Coastal Commission to conduct additional feasibility studies and to begin the permitting process. Is a detailed breakdown of how those funds will be spent publicly available? Will the studies and permits be exclusively focused on SMBRC's favored alternative? Has any money been set aside to study what could be achieved via any of the other alternatives?

In the unsourced 2006 Goals, Opportunities and Constraints document posted on the project web site, it was acknowledged that "Because the size of the site is limited, it may not be possible to incorporate large enough patches of all historic habitat types to ensure their viability." As such, why hasn't any money been set aside for acquisition of adjacent lands in the Ballona ecosystem?

The web site currently indicates that the restoration project is scheduled to commence in 2012. Does that refer only to the planning and permitting phase, or actual implementation of the plan (i.e. habitat alteration).

In order to make informed decisions, stakeholders should clearly understand the current state of the wetlands and also what specific gains will be realized by a larger scale project that could not also be realized by a smaller scale project. I understand that SMBRC has invested considerable time and effort into establishing baselines with its volunteer monitoring project, but when it comes to pitching the proposed restoration project to the public, I believe that SMBRC's assertions are quite misleading. While I certainly understand the desire to present your preferred approach in the most positive light, I do not believe that this approach is in the public interest.

I do not know which species stand to gain and which stand to lose as a result of the proposed project. I still do not know how different factors such as water quality, wildlife diversity, public recreation and others have been weighted into the decision making criteria. I don't think it is unreasonable to expect this level of information for such an important project impacting an ecosystem that took decades to protect.

If the present levee is removed, the need for berms/levees for flood control seem to cover almost 30% of our very fragile and limited wetlands. A plan that allows a small amount of salt/fresh water could be allowed into Ballona, but without any of the major bulldozing that the Coastal Conservancy wants to do.

From my readings, it is better to reduce pollution with constructed wetlands specifically design for this purpose instead of discharging polluted water directly into a natural wetland. We need to acquire additional land for water treatment – Ballona Creek is too polluted to be directly diverted to the Ballona Wetlands.

Our Ballona Wetlands need to be restored/repared over time. The creek was channelized, then the Marina dredge was dumped, yet we have many working ecosystems presently. We need to move slowly to recover water flow functions. If Ballona is bulldozed we will lose the natural environments that have evolved. We need SLOW community engaged restoration with experienced, knowledgeable biologists guiding and observing the process. We need to create and retain a mosaic of as many different habitats as possible.

Thank you and I hope all of my concerns and those of others will enable a gradual restoration of the Ballona Wetlands.

*Donna Murray*

Donna Murray  
8734 Wiley Post Avenue  
Los Angeles, CA 90045  
310 258-9488  
dlmurray47@gmail.com

## Jones, Tanya

---

**From:** Rick P [<mailto:seerixpix@yahoo.com>]  
**Sent:** Sunday, October 21, 2012 11:34 PM  
**To:** Walter Lamb  
**Cc:** [landtrust@ballona.org](mailto:landtrust@ballona.org); McCormick, Donna  
**Subject:** Re: Final scoping comments

Hello Walter, Donna,

I had planned to provide you with many comments and observations, but life happens and it just never came to fruition. However, after reading your draft I feel very relieved that you pretty much got it all and my comments and observations would mostly have been redundant anyway so first let me commend you all for the outstanding work thus far on the draft.

I don't think I saw the "2012 Preferred Alternative" until tonight and I have to say, it's rather disturbing.

Here's a few things, "comments" if you will, that come to mind when I look at this drawing.

1. Where is the bike path? There is no mention of a bike path in the legend. Are they insane? The bike path goes from downtown LA to Redondo Beach. Do they really plan to stop the bike path at Lincoln or maybe even the Marina freeway? Literally cutting off bike access to the foot bridge at the beach (near Del Rey Lagoon)? It can't be, the public outcry would be of historical proportion.
2. There is a severe lack of explanation and details on the drawing in general, especially if you consider how much research and planning that has been done.
3. What's up with the massive levee that completely surrounds Area A and most of B? That looks crazy, would animals be able to traverse it? Not that they don't risk being road kill on the Culver Bl. if they do it now, but I'm just saying!
4. The plan shows existing and planned trail networks that in some cases are not even possible. One goes right through the Gas Company plant, that'll never happen, and they show old Cabora Road as an existing trail, um, no, not really, it used to be fenced off at Lincoln, I don't think it's intended for public access.
5. The plan shows planned trail networks right through the middle of Area A and loops in Area C north and south. My experience tells me the existing wildlife and migrant birds that visit Ballona are fairly tolerant of pedestrians, based on the fact that they come fairly close to the fence despite the foot and bike traffic on the bike path, but that's not what bothers me about them planning trails for public access, what bothers me is the constant maintenance that will result. At the very least there will be maintenance crews just to keep them clean and accessible, worst case scenario it will become very "Park" like and they will constantly groom the area around the trails so the public can see more than a few feet from the trail. I can see it now, weed whackers and chain saws. Not to mention how many people will wander off the trails. That sort of activity will send sensitive wildlife running for the hills.
6. Managed Marsh for Area B south of Culver? Really? I don't know, it just sounds like too much human intervention all the time. I realize there is an existing gate already at where the creek feeds into the Salt Water Marsh, but I also noticed that only the smallest fish will venture through that gate, so to me all these "managed" gates and marshes translate to "man's intervention" and will prevent nature (wildlife) from doing what it wants to, and many fish that would normally wander up those estuaries to spawn are going to turn around when they see those gates.

As much as my mind is probably just getting rolling with all the things that don't sit right with me regarding this plan, it's 11:30pm and my alarm will ring at 5:15am. I better get some rest for work tomorrow. I will try to put some more thoughts to the keyboard tomorrow night.

Take care and keep up the good work, Rick

Rick Pine  
310-902-8993

-----  
Dear Wetlands Supporters,

Now is our last, best chance to influence the proposed restoration plan for the Ballona Wetlands. Final scoping comments are due next Tuesday, October 23rd. We've made it easy for you to take part by following a list of steps depending on how much time you have. Doing a little bit is much better than doing nothing at all, so please try to submit something, so that the project team at least knows that you care about this ecosystem that we've worked so hard to preserve.

Submitting Comments (Quick and Easy Option):

1) Go to Jonathan Coffin or Rick Pine's flicker pages and find a wetlands species or two (bird, butterfly, spider, plant or whatever) that really catches your eye.

<http://www.flickr.com/photos/stonebird/sets/447673/>

<http://www.flickr.com/photos/seerixpix/>

2) If you have time, do some quick research on that species. What kind of habitat do they favor? What are its food sources? What is its status federally and in California?

3) Take whatever you have learned, or even just the species name itself, and ask that the project team study the impact on that species of the various restoration alternatives being considered. Is the habitat and food sources that this species depends on likely to increase or decrease? What possible ripple effects or unintended consequences could impact this species?

4) Email your comments to Donna McCormick ([Donna.McCormick@icfi.com](mailto:Donna.McCormick@icfi.com)) and please copy us ([landtrust@ballona.org](mailto:landtrust@ballona.org))



# Ballona Wetlands Restoration Project

Advancing ecosystem health. Connecting communities with nature.

## Comment Card

Name: Stephanie Beckman

Email: (optional) beckmans@earthlink.net

Add me to the mailing list (please provide email or mailing address): \_\_\_\_\_

Comments/Issues: (Use additional sheets if necessary) PLEASE EVALUATE  
SPECIES LEVEL IMPACT FOR REMOVALS LEVELS  
AND ADDING WATER TO CURRENT SALT PAN  
PLEASE EVALUATE SPECIES LEVEL (i.e. LOBBERS CREEK)  
IMPACT ON SPEED OF RESTORATION IN SECTIONS.  
PLEASE EVALUATE IMPACT OF PROPOSED  
PLANS TO OPTIONS NOT CHOSEN.  
PLEASE EVALUATE LONG-TERM IMPACT  
OF 15 - 20' FOOT BURNS AROUND CURVE  
! JEFFERSON. PLEASE EVALUATE IMPACT  
ON MIGRATORY BIRDS IF HYDROLOGY  
IS ALTERED AT BALLONA WETLANDS.  
PLEASE EVALUATE IMPACT OF UNFILTERED POLLUTION & TOXINS  
ENTERING THE WETLANDS THANK YOU - Stephanie  
FROM BALLONA CREEK  
AND MITIGATION PLANS.

Submit written comments by **October 23, 2012** to:

Mail: Ballona Wetlands Restoration Project  
C/O Donna McCormick  
1 Ada, Suite 100  
Irvine, CA 92618

Email: [Donna.McCormick@icfi.com](mailto:Donna.McCormick@icfi.com)

**\*\*All comments submitted will become part of the Public Record**

Tape Here  
Do Not  
Staple

Fold Here

*to Beekman*  
8635 FAIRMOUNT #301  
FOYIA One West CA 92618

LOS ANGELES CA 900

22 OCT 2012 PM 2 T

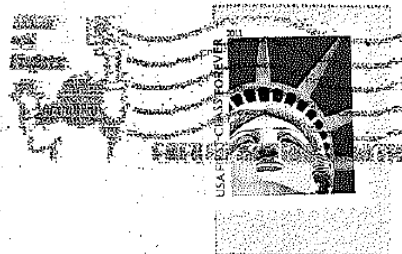

**Ballona Wetlands Restoration Project**  
**C/O Donna McCormick**  
**1 Ada, Suite 100**  
**Irvine, CA 92618**

A-271

**Jones, Tanya**

---

**From:** micheleanna b [<mailto:micheleanna@gmail.com>]

**Sent:** Monday, October 22, 2012 7:55 PM

**To:** McCormick, Donna

**Subject:** comment re Ballona Wetlands Restoration

To whom it may concern, I would like to submit comments on the plans for restoration of the Ballona Wetlands:

I have lived in Los Angeles nearly all my life, and I have worked to help clean up Santa Monica Bay and to save the Wetlands from development.

I live less than a block from Ballona Creek and walk or ride along the bike path through the Wetlands nearly every day. I also kayak at the mouth of Ballona Creek often. I know the wetlands very well.

In my opinion the plan promoted by SMBRC is far too drastic and indeed destructive. The wetlands have evolved over the years since the creation of the Marina, and they are now a vibrant ecosystem filled with birds both local and migratory. Ballona Creek has fish and turtles and birds, and butterflies and other insects also find refuge in the Wetlands. I see all this every time I go through the wetlands, or walk down to the creek.

The area could use some improvement, of course. But the changes should be small and incremental, not the huge, irreversible, destructive bulldozer plans suggested by SMBRC.

I envision some removal of non-native plants; the addition of a perimeter bike path, and viewing platforms and paths for birds and other nature lovers; and perhaps a SMALL change in the levees to permit more tidal access.

But the existing uplands, dunes, salt pan should be preserved, for the hawks, kites, egrets, ducks, geese, and many other creatures that find a rare respite from the urban landscape there.

Let us not destroy the precious habitat we already have--for the extremely uncertain results of the SMBRC plan.

Thank you,  
Michele Bigelow



## Jones, Tanya

---

From: Cadwallader, Joe [mailto:joe.cadwallader@boeing.com]  
Sent: Monday, October 22, 2012 10:37 AM  
To: McCormick, Donna  
Cc: president@villamarinacouncil.com; 'Editor@VillaMarinaCouncil.com'; jewel.johnson@mrca.ca.gov; LINDSSTAR@aol.com; 'Richard Reece'; 'Celinda Jungheim Disaster Planning'; 'Stanleyand Renata Epstein'; naidanjoe@verizon.net  
Subject: FW: Ballona Wetlands Restoration Project Comments

Donna:

Corrected your email address, thanks to Carolyn Everhart at MRCA.

Please see below.

Very best regards,

Joe M. Cadwallader  
Engineer-Scientist 4  
C-17 Avionics Engineering  
Boeing Long Beach, CA.  
562-826-7488 Cell

-----Original Message-----

From: Joe Cadwallader [mailto:naidanjoe@verizon.net]  
Sent: Sunday, October 21, 2012 7:56 PM  
To: Donna.McCormick@icfri.com  
Cc: president@villamarinacouncil.com; 'Editor@VillaMarinaCouncil.com'; jewel.johnson@mrca.ca.gov; LINDSSTAR@aol.com; 'Richard Reece'; 'Celinda Jungheim Disaster Planning'; 'Stanleyand Renata Epstein'; Cadwallader, Joe  
Subject: Ballona Wetlands Restoration Project Comments

October 21, 2012.

Donna:

As the property owner & occupant, and property tax payer of the residential townhouse unit that is closest to Area-C at the far east end of La Villa Marina, with intimate knowledge of the Area-C situation since our occupancy in late 2001, may I offer comments on the proposed Ballona Wetlands Restoration Project as it relates to Area-C in particular. My comments are directed to the concerns we have as local area residents regarding this Project maintaining and not negatively impacting the safety & protection, peace & quiet, and investment value & equity of our neighborhood.

\* AREA-C RESTORATION ACTIVITY: We are totally opposed to any Area-C restoration activity being conducted or accomplished via access at the east end of La Villa Marina. The impact to the entire neighborhood would be completely unacceptable. All such restoration access for this Project must be confined to and accomplished from the intersection of Culver Blvd and the Marina Freeway (90).

\* AREA-C ACCESS via LA VILLA MARINA: We are absolutely opposed to any future "Public Access" whatsoever to Area-C via the east end of La Villa Marina. Again, the impact to the entire neighborhood would be completely unacceptable on a long-term basis. Over the years, we have been subjected to the problems resulting from homeless squatters illegally accessing Area-C by way of this location, and such is completely unacceptable in any dense residential neighborhood such as ours. We've seen it in action: it does not work.

\* AREA-C PUBLIC ACCESS: Because of the past & present issues in Area-C due to homeless squatters, we are absolutely opposed to "Public Access" to the interior of Area-C at all. The "public" must be kept out of Area-C, and the Project should be directed to putting effective means in place - read fencing - that will accomplish this objective. Area-C Viewing locations - such as those previously developed along the south side of Jefferson Blvd. west of Lincoln Blvd. - would be acceptable and appropriate along Culver Blvd. south of the Marina Freeway, and would bring the "usage" issue of Area-C into conformance with that of the already restored area south of Jefferson & west of Lincoln. Any greater "usage" of Area-C is completely unwarranted and undesirable, and is strongly opposed by this residential community.

\* AREA-C FENCING: Denying general public access requires effective fencing of the area, and such an effort would necessarily be a significant component of this Restoration Project. Not only would existing old and dilapidated chain-link fencing need to be replaced with something far more robust, but also aging concrete block fences surrounding the area - many of which in serious states of decay after standing unmaintained since 1965 - would need to be demolished and replaced using a consistent design & construction approach throughout the entire Project. Many of the old concrete block fences are strictly speaking the private property of the specific Villas they bound, virtually none of whom would be in a financial position to pay outright for their replacement. To "do it RIGHT" will necessitate a significant effort of coordination and negotiation with all such Villas, resulting in this issue becoming a significant impact to the Project's total costs and schedule.

\* AREA-C WILDLIFE & WATERSHED: The effective fencing issue above begs the question of preserving the free access and movement of water and wildlife in this area, which should be a primary objective of the Project. Diligent Engineering must be applied to the issue to accomplish this objective.

The Restoration Project's careful attention to and consideration of the above issues will assure a successful Project and a supportive neighborhood.

With best regards and wishes for a very successful Area-C Restoration Project,

Mr & Mrs. Joe M. Cadwallader  
4812-J La Villa Marina  
Marina del Rey, CA. 90292



# Ballona Wetlands Restoration Project

Advancing ecosystem health. Connecting communities with nature.

## Comment Card

Name: \_\_\_\_\_

Moley Curtis

Email: (optional) \_\_\_\_\_

molly ~~curtis~~ esq@pachell.net

Add me to the mailing list (please provide email or mailing address): \_\_\_\_\_

Comments/Issues: (Use additional sheets if necessary) \_\_\_\_\_

Preserve

Don't restrict Bike Access

Preserve great blue heron habitat

Submit written comments by **October 23, 2012** to:

Mail: Ballona Wetlands Restoration Project

C/O Donna McCormick

1 Ada, Suite 100

Irvine, CA 92618

Email: [Donna.McCormick@icfi.com](mailto:Donna.McCormick@icfi.com)

**\*\*All comments submitted will become part of the Public Record**

Tape Here  
Do Not  
Staple

Fold Here

SANTA CLARITA CA 913

27 OCT 2012 PM 1 1



**Ballona Wetlands Restoration Project**  
**C/O Donna McCormick**  
**1 Ada, Suite 100**  
**Irvine, CA 92618**

**Jones, Tanya**

---

**From:** Scott Garvey [<mailto:scottgarvey02@yahoo.com>]

**Sent:** Monday, October 22, 2012 3:53 PM

**To:** McCormick, Donna; [daniel.p.swenson@usace.army.mil](mailto:daniel.p.swenson@usace.army.mil); [DLawhead@dfg.ca.gov](mailto:DLawhead@dfg.ca.gov); [jainsworth@coastal.ca.gov](mailto:jainsworth@coastal.ca.gov); [gtimm@coastal.ca.gov](mailto:gtimm@coastal.ca.gov); [rising.nicky@coastal.ca.gov](mailto:rising.nicky@coastal.ca.gov); [cliff.costa@sen.ca.gov](mailto:cliff.costa@sen.ca.gov); [jennifer.zivkovic@sen.ca.gov](mailto:jennifer.zivkovic@sen.ca.gov); [elise.swanson@mail.house.gov](mailto:elise.swanson@mail.house.gov); [clester@coastal.ca.gov](mailto:clester@coastal.ca.gov); [councilmember.rosendahl@lacity.org](mailto:councilmember.rosendahl@lacity.org); [kathy.knight@verizon.net](mailto:kathy.knight@verizon.net)

**Subject:** Comments on State's plan for the Ballona Wetlands Restoration Project

I'm writing in regards to the massively destructive restoration State Plan for the Ballona Wetlands.

I need not remind you that Los Angeles has run out of wetlands, and that this is the last one remaining.

Please see my comments in the attached file.

Respectfully,

Scott Garvey

# Scott Garvey

1559 N. Bundy Drive, Los Angeles, CA 90049 Email: [scottgarvey02@yahoo.com](mailto:scottgarvey02@yahoo.com)

---

October 22, 2012

To: Ms. Donna McCormick, Ballona Wetlands Restoration Project  
Mr. Daniel P. Swenson, Chief, Los Angeles section Army Corps of Engineers  
Mr. Charles Lester, Executive Director, California Coastal Commission  
Mr. John Ainsworth, Sr. Deputy Director, California Coastal Commission, South Coast District Office  
Mr. Gary Timm, District Manager, California Coastal Commission, South Coast District Office  
Mr. David Lawhead, California Dept. of Fish and Game  
Honorable Edmund G. Brown Jr., Governor of California  
Honorable Janice Hahn, U.S. representative, 36th Congressional District  
Honorable Ted Lieu, CA State Senator, 28th District  
Honorable Bill Rosendahl, Councilmember, City of Los Angeles, 11th District  
Ms. Kathy Knight, Conservation Chair of the Sierra Club Airport/Marina Group

From: Scott Garvey

Re: Comments on Notice of Preparation of a Draft EIS/EIR for Ballona Wetlands Restoration Project

I'm writing in regards to the massively destructive restoration State Plan for the Ballona Wetlands. I need not remind you that Los Angeles has run out of wetlands, and that this is the last one remaining. I need not remind you that Los Angeles does not have any open space ecosystem on the entire flatlands of Los Angeles County. The formerly huge Ballona Wetlands have been so severely obliterated over the years by mega developments such as Marina Del Rey and Playa Vista. When is enough enough? Once you've completely annihilated the vast ecosystems of Los Angeles to absolutely nothing?

As an Angeleno bike riding and running along the Ballona Creek several times a week for over twenty years I am extremely concerned with the State's proposals and methods for restoration of the small remaining area of Ballona Wetlands.

The following is a list of my concerns in no particular order.

**First**, can the same animals, birds, plants, and species that live or visit in a saltwater marsh also live in a freshwater marsh, and vice versa? We need further research to the history of the Ballona Wetlands to the legitimacy of the type of marsh that the original habitat supported. This may not even be documented, and any restoration proposal poses a serious threat to the existing native habitat and its native species.

**Second**, the State plan is obviously not environmentally sound and needs more input and oversight from environmental scientists who understand the science of biodiversity, ecosystem integrity, and the critical ecological impacts to manage the land. Thus, if human use and the restoration process is considered, it will be very minimal to the fragile Ballona Wetlands ecosystems and habitats.

The State's current proposed restoration plans will permanently alter and destroy this fragile ecosystem. As a result of the State's proposal the endemic species and the Ballona Wetlands ecosystems will be unequivocally damaged to an irreversible state, thus leading to its loss forever.

# Scott Garvey

1559 N. Bundy Drive, Los Angeles, CA 90049 Email: [scottgarvey02@yahoo.com](mailto:scottgarvey02@yahoo.com)

---

Comments on Notice of Preparation of a Draft EIS/EIR for Ballona Wetlands Restoration Project  
October 22, 2012

Page two

**Third**, I do not support the audacity of the State's environmental agencies and their experts opening up this fragile wetlands ecosystem to the public. It is absurd to open this protected area to people because of the likelihood of negative human impact, such as carelessly tromping and littering, and negatively impacting adjacent areas not designated as trails, among other adverse impacts. This proposal to open up the Ballona Wetlands ecosystem to the public is a blatant display of carelessness, disregard, and neglectful environmental assessments used in the State's proposal to restore any type of ecosystem. This makes absolutely no sense and because of this, any other restoration proposed in the State's plan in my opinion lacks credibility and leaves room for major error and concern.

**Fourth**, Any environmental scientist would be seriously concerned with any type of industrial - scale habitat conversion, involving bulldozing and excavating, removing 1.8 million cubic yards of earth, removing, moving and building levees, and lowering the elevation of the habitat will definitely adversely impact and destroy the current wetlands ecosystems, habitats, and its native species.

"Relocating the levees would come at enormous financial expense and then leave us with an unnatural system that will have a tendency to be filled with sediment and will have the pollution that is currently constrained to the channel discharged into a cookie-cutter abstraction of a fully tidal wetland that destroys existing natural features to create something that was not there prior to our disturbance of the system," stated by Professor Travis Longcore, an associate professor at the UCLA Institute of the Environment and Sustainability.

**Fifth**, There should be serious concerns by any environmental scientist or agency to the State's proposed restoration plans initiative to bring a polluted Ballona Creek into the Wetlands. Using the Ballona Wetlands as a clean up basin for all the street runoff and garbage from higher areas around Los Angeles is absurd. We don't want that, it is too polluted. Common sense should be to clean up Ballona Creek first before bringing it into the Ballona Wetlands. Preventing all street runoff and people from throwing garbage into Ballona creek or other Los Angeles basin water areas in my opinion is impossible, and thus using Ballona Wetlands as an end of the line basin for any part of Ballona Creek should not even be considered.

**Sixth**, To conserve rare and endangered species, you have to take into account each one of them on an individual basis. The State's proposal does not even include what species are to be protected, what species are native to the Ballona wetlands ecosystems, and what their proposed methods are to preserve the native plant, animal, and insect species habitat and integrity.

**Seventh**, and probably most important I also feel that because it is widely known that this area is an important archeological and historical site, as well as even being a registered sacred site comprised of Native American Tongva tribal land, who have been living there for 10,000 years, with sacred artifacts and burial grounds, little to no impact should be our upmost goal. The Playa Vista developers dug up over 1400 of their ancestors' graves. They are the indigenous people of Los Angeles and we need to support what their wishes are. It is time we start respecting their culture and do what is right.

# Scott Garvey

1559 N. Bundy Drive, Los Angeles, CA 90049 Email: [scottgarvey02@yahoo.com](mailto:scottgarvey02@yahoo.com)

---

Comments on Notice of Preparation of a Draft EIS/EIR for Ballona Wetlands Restoration Project  
October 22, 2012  
Page three

**Eighth**, We, the public need to have more time for public comment and review. This should not be limited to only one meeting, this is unfair and unjust. The public needs more time to review, analyze, scrutinize and give input to the State's proposals for restoration of the Ballona Wetlands Ecosystems.

Please strongly consider my concerns. As environmental State agencies representing the integrity of California's limited natural habitats and ecosystems consider the adverse impacts of human use, management, and restoration. Instead, it should be your utmost goal to preserve the integrity and biodiversity of these rare native ecosystems, habitats, and species. As a proclaimed and certified environmental scientist working for the State your motive should not be financial gain. Unfortunately, I have my doubts when it comes to bureaucracy.

Thank you for your consideration. I would appreciate your confirmation of your receipt of this email and your efforts to see that it also gets forwarded to the appropriate parties.

Sincerely,

Scott Garvey



RECEIVED

OCT 25 2012

REGULATORY DIVISION  
LOS ANGELES OFFICE

Lauren Gottlieb, MSW  
2900 4<sup>th</sup> St #16  
Santa Monica, Calif. 90405

October 22, 2012

Daniel P. Swenson, Chief  
Los Angeles Section  
Army Corps of Engineers  
915 Wilshire Blvd  
Los Angeles, CA 90007

David Lawhead  
Terri Stewart  
Calif. Dept of Fish and Game  
3883 Ruffin Road  
San Diego, CA 92123

Mr. Swenson, Mr. Lawhead, Ms. Stewart:

I share a vision of Earth with many people, including children, wherein we humans live in a sustainable environment for generations to come.

Micromanagement of crucial ecosystems has become the norm and will not work in the long run. From what I can see so far, the tentative Ballona Wetlands plans are short-sighted. My hope is that federal recognition of this land, which is legally the case, will bring a better future for all concerned. For now, California taxpayers bought the land to save it; this taxpayer would like to see better long-term planning based on science.

As an intelligent, concerned citizen, I have listened to several project scientists and know that the caliber of the studies so far is fairly high. My hope is that Army Corps, and Fish & Game, will be diligent and listen to all of the scientists (without pointing fingers).

As I am aware of many Ballona Wetlands conflicts and hopes, I could comment on several things, but I won't. I will simply point out the following:

Wetlands are the key to life on Earth. Winged Migrations count on intact ecosystems. One rainy year on my commute I remember seeing the Blue Egrets and White Herons in a Ballona Wetlands pond. These big birds are awe-inspiring, and their nesting seasons, according to Audubon scientists, last about eleven months of the year. If any work is done, unless it is limited to that one month per year, they will be gone forever from this area. Bottom line impact.

So my vote, which I am sure is shared by anyone who appreciates Big Birds, is to limit the timing scope of anything done in the Ballona Wetlands to that one safe month once a year. Kind of like Christmas.

Sincerely,

*Lauren Gottlieb, MSW*  
Lauren Gottlieb, MSW



# Ballona Wetlands Restoration Project

Advancing ecosystem health. Connecting communities with nature.

## Comment Card

Name: CINDY GRANT

Email: (optional) cindy@cindygrant.com

Add me to the mailing list (please provide email or mailing address): \_\_\_\_\_

Comments/Issues: (Use additional sheets if necessary) REGARDING THE PROPOSED RESTORATION I AM CONCERNED ABOUT THE FOLLOWING 6 ISSUES:

① POLLUTION CONTROLS

② PROTECTING EXISTING ~~FLORA~~ FLORA & FAUNA - DOCUMENT & DESCRIBE HOW THIS WOULD BE DONE.

③ COST OF MAINTENANCE OF PREFERRED OPTION - THIS AREA HISTORICALLY WOULD CLOSE OFF ANNUALLY AND I WOULD HATE TO SEE AN OPTION THAT HAS TO BE DREDGED ANNUALLY AS SOME SIMILAR RESTORATIONS.

④ LARGE LEVEE ALONG CULVERT IN PREFERRED ALT. - CAN WE RAISE CULVERT INSTEAD? - A LARGE LEVEE WOULD BISECT THE ENVIRONMENT & DISRUPT VIEWS.

⑤ PROTECTION OF FERAL CATS - PLEASE ADDRESS HOW HUMANE EFFORTS OF TRAP/SPAY & RELEASE & SLOW RELOCATE COULD BE USED - LOCAL ORGS. LIKE CATNIPPERS OR FERAL CAT CARETAKERS COALITION SHOULD BE ENLISTED FOR ASSISTANCE.

⑥ ACQUISITION OF ANY USEFUL ADJACENT ~~PROTECTED~~ LAND.

⑦ I PREFER SLOW RESTORATION SO ANIMALS & INSECTS CAN ADJUST.

Submit written comments by October 23, 2012 to:

Mail: Ballona Wetlands Restoration Project

C/O Donna McCormick

1 Ada, Suite 100

Irvine, CA 92618

Email: [Donna.McCormick@icfi.com](mailto:Donna.McCormick@icfi.com)

**\*\*All comments submitted will become part of the Public Record**

Tape Here  
Do Not  
Staple

Fold Here

Audubon



Mr Scott Hutchinson  
14971 Sutton St  
Sherman Oaks CA 91403

**Ballona Wetlands Restoration Project**  
**C/O Donna McCormick**  
**1 Ada, Suite 100**  
**Irvine, CA 92618**



**Jones, Tanya**

---

**From:** Steffi Jones [<mailto:ibu70@hotmail.com>]

**Sent:** Monday, October 22, 2012 2:30 PM

**To:** McCormick, Donna

**Subject:** ballona wetland restoration

Hello,

I am writing because of my concern in regards of the restoration plans of the ballona wetlands.

I am concerned with the impacts on species like the California Brown Pelican or the Cross-eyed Bubo. Will the project team study the impact on these species by restoration alternatives?

Best ,  
Steffi

**Jones, Tanya**

---

-----Original Message-----

From: [longcore@usc.edu](mailto:longcore@usc.edu) [<mailto:longcore@usc.edu>]

Sent: Monday, October 22, 2012 9:24 PM

To: McCormick, Donna

Cc: David Lawhead; [daniel.p.swenson@us.ace.army.mil](mailto:daniel.p.swenson@us.ace.army.mil)

Subject: Ballona Wetlands Project Notice of Preparation

Dear Ms. McCormick,

Please see attached comment on the Ballona Wetlands Project Notice of Preparation.

October 22, 2012

Ballona Wetlands Restoration Project  
C/O Donna McCormick  
1 Ada, Suite 100  
Irvine, CA 92816

To Whom It May Concern:

Please consider the following comments in preparation of the Draft Environmental Impact Report/Environmental Impact Statement for the Ballona Wetlands Restoration Project. These are my personal comments and do not represent an official position of the University of Southern California or any of my other employers. *The use of letterhead is for identification and contact purposes only.* I am an urban ecologist with a long history of research on ecological restoration (Longcore 2003; Longcore 1999; Longcore et al. 2000) and management of natural ecosystems to support native biodiversity in southern California, with more recent research on the historical conditions of coastal estuaries and riparian systems in the region (Dark et al. 2011; Jacobs et al. 2011; Stein et al. 2010; Stein et al. 2007).

First, the project description should be corrected to describe the project as wetlands “creation” not “restoration.” The proposed project in the NOP does not represent “the return of an ecosystem to a close approximation of its condition prior to disturbance,” which is a widely accepted definition of “restoration” (National Research Council 1992). The ending conditions depicted in the NOP have not been present in the system for over 2,000 years (Dark et al. 2011; Palacios-Fest et al. 2006) and would be, in fact, out of equilibrium with the hydrogeomorphological forces present in the current day watershed (Jacobs et al. 2011). The site will not be “restored” by introducing permanent tidal flows. Rather, in its historical condition prior to being jettied open to the ocean, the Ballona wetlands were only open to the ocean periodically in response to winter rains. As summarized by Dark et al. (2011):

Approximately half of the aggregate Ballona Lagoon area consisted of a freshwater and tidally affected saltmarsh and brackish habitats that transitioned into a more alkaline/freshwater system about 1.5 miles (2.4 km) inland. Historical habitat of the Ballona Lagoon coastal complex consisted of substantial amounts of brackish to salt marsh/tidal marsh habitat (29%), followed by salt flat/tidal flat (10%). Open water made up less than 3 percent of the lagoon and one of the more

salient features of the complex was a long but narrow strip of open water referred to by some as a “lake” at what we call today Del Rey/Ballona Lagoon (Sheridan 1887). This strip of open water periodically emptied into the ocean at the documented location of seasonal tidal access (figure 22). **We found no evidence that the lagoon remained perennially open, but rather the textual sources indicate that access to the ocean depended on hydraulic forces during any given year** (LAT 1887, Sheridan 1887, Hansen and Jackson 1889, Solano 1893). The migration of the Los Angeles River away from the lagoon transitioned the system into a lower energy system where only on rare occasions was there enough freshwater flow from Ballona Creek to break through the buildup of sediment along the coast. As a result, gradual build up of sediment around the terminus of the previous estuary formed dunes and created this “trapped” lake-like feature. The coastal dunes, which occupied four percent of the Ballona Lagoon coastal complex, played a significant role in the formation of the lake and the limited tidal access (see Jacobs et al. 2011).

Therefore, the creation of a meandering channel for Ballona Creek as described in the NOP would not be a “restoration.” The historical system did not have a large main channel. Changing the shape of an unnatural channel does not “restore” it.

Moving the channels will not “restore” the wetlands. To the contrary, it would introduce permanent tidal flow to areas that did not historically have such flows. The EIR/EIS should be accurate in the use of the term “restoration” and not extend it to the creation of novel wetland systems that, because they would not be supported by the existing or proposed hydrology, would require significant maintenance (i.e., dredging) to maintain and would destroy existing biodiversity.

Because the proposed project is not in any way a restoration, but rather represents creation of a distribution of wetland types that is novel in the project location, I request that the alternatives analysis include consideration of an alternative that has the following characteristics:

1. Does not adversely impact features on the landscape that have been stable since the late 1800s. This includes the dune system, various salt pan areas, and existing brackish to saltmarsh habitat currently dominated by native species. That is, all native habitats that roughly correspond with their historical locations are not disturbed. Essentially, “First, do no harm.”
2. Does not remove the levees, because these unnatural structures serve the role of the barrier dune that separated the wetland system for the ocean. Their removal unnaturally opens the wetlands area up to permanent tidal flow and would introduce pollution from Ballona

Creek into the wetlands area. The alternative should use tidal gates and active management to create explicitly desired wetland conditions to support rare and endangered species that were historically present in the wetlands system.

3. Has explicit rare or endangered target species that were historically present in the Ballona wetlands complex (prior to the late 1880s) and could recolonize or be reintroduced following restoration. The current project description inexplicably does not list maintenance or restoration of native biodiversity as a goal, so an alternative with biodiversity conservation as a goal should be developed and considered.

I ask that the two attached documents be made part of the record for the EIR/EIS and be considered carefully when weighing the alleged benefits of creating a full-tidal system by removing the levees (see especially the discussion in Jacobs et al. 2011).

I am deeply concerned that the State has proposed a project that is a cookie-cutter abstraction of a generic coastal wetland of a particular type that was not historically present. Pursuing a perennially full tidal design will result in a homogenization of the wetland types found regionally and will be plagued by the same maintenance issues that have been encountered at other projects that artificially open what would naturally be closing estuaries (e.g., Bolsa Chica).

Sincerely,



Travis Longcore, Ph.D.

## Literature Cited

- Dark, S., E. D. Stein, D. Bram, J. Osuna, J. Monteferrante, T. Longcore, R. Grossinger, and E. Beller. 2011. Historical ecology of the Ballona Creek watershed. Southern California Coastal Water Research Project. Technical Report #671.
- Jacobs, D., E. S. Stein, and T. Longcore. 2011. Classification of California estuaries based on natural closure patterns: templates for restoration and management. Southern California Coastal Water Research Project Technical Publication No. 619a.
- Longcore, T. 2003. Terrestrial arthropods as indicators of ecological restoration success in coastal sage scrub (California, USA). *Restoration Ecology* 11:397–409.
- Longcore, T. R. 1999. Terrestrial arthropods as indicators of restoration success in coastal sage scrub. Pages 1–145. Department of Geography. University of California, Los Angeles.
- Longcore, T. R., R. Mattoni, G. F. Pratt, and C. Rich. 2000. On the perils of ecological restoration: lessons from the El Segundo blue butterfly. Pages 281–286 in C. J. Fotheringham, editor. 2nd Interface Between Ecology and Land Development in California. U.S. Geological Survey Open



- File Report 00-62, Sacramento.
- National Research Council 1992. Restoration of aquatic ecosystems: science, technology, and public policy. National Academy Press, Washington, DC.
- Palacios-Fest, M. R., J. A. Homburg, E. C. Brevik, A. R. Orme, O. K. Davis, and S. D. Shelley. 2006. Late Quaternary palaeoecology of Ballona Lagoon in southern California. *Ciencias Marinas* 32:485-405.
- Stein, E. D., S. Dark, T. Longcore, R. Grossinger, N. Hall, and M. Beland. 2010. Historical Ecology as a Tool for Assessing Landscape Change and Informing Wetland Restoration Priorities. *Wetlands* 30:589-601.
- Stein, E. D., S. Dark, T. Longcore, N. Hall, M. Beland, R. Grossinger, J. Casanova, and M. Sutula. 2007. Historical ecology and landscape change of the San Gabriel River and floodplain. SCCWRP Technical Report #499. Southern California Coastal Water Research Project, Costa Mesa, California.

**Jones, Tanya**

---

**From:** Donna Murray [<mailto:dlmurray47@gmail.com>]

**Sent:** Monday, October 22, 2012 1:50 PM

**To:** McCormick, Donna

**Subject:** Ballona Wetlands Restoration Project

Ballona Wetlands Restoration Project

c/o Donna McCormick

1 Ada, Suite 100

Irvine, CA 92618

Re: NOI Ballona Wetlands Restoration 10/21/2012

I have spent the last 20 years fighting to preserve as much of the wetlands as possible and now I have read the following: Wetlands Explained by William M. Lewis, In Search of Swampland by Ralph W. Tiner, Wetlands by Peter D. Moore, and Wetlands by Max Finalyson and Michael Moser to try to better understand wetlands and to look at the alternatives with a more educated perspective. I have recently begun attending the Santa Monica Bay Commission Meetings, I attended one community event and I attended the scoping venue and I have many unanswered questions.

When you refer to "the restoration project" or simply "the project", are you referring to a specific project alternative, or more generically to the process of selecting and then implementing an alternative? Many public statements seem to indicate the former and others seem to indicate that a final decision on which alternative to pursue has not yet been made.

Why must we proceed with the most expensive and most risky solution straight away rather than first seeing what can be achieved with a lower cost and lower risk alternative?

Won't the highly polluted water from the Ballona Creek harm the Ballona Wetlands ecosystem if the levees are breached and that water is allowed to flow directly into the ecosystem?

What plan is in place to clean up the stream before it reaches the wetlands, and what is the timeline for such a plan to be implemented?

Won't this project relieve the state government and local city governments of the pressure to do more to clean the water in the Ballona Creek further upstream?

You have compiled a baseline monitoring report for the current biological diversity of this ecosystem. Have you made any projections as to how different species of animals and plants are likely to be affected by the various project alternatives? For instance, there are a number of birds in the baseline report that favor upland habitat, and upland habitat would decline significantly under the favored project alternative. Would not those species therefore be expected to decline if those alternatives are implemented? Are there charts that can help us better understand how each species is expected to fare?

The assessment of the various project alternatives seems entirely based on the goal of increasing estuarine habitat. How was that goal established and how was the benefit of increased estuarine habitat balanced against the loss of upland habitat and other types of habitat?

What will be the increase in distance in the Ballona Creek bike trail (from beginning of the new route to end of the new route) as a result of the proposed rerouting? Will there be portions of the creek that are no longer accessible from the bike trail?

Is it possible that the project will ultimately be funded by mitigation dollars from another development project elsewhere in the area that will have a negative impact on the overall health of the area's ecosystems? In other words, could accepting funds for this project pave the way for other wetlands ecosystems to be compromised?

SMBRC recently received \$6.25 million from the California Coastal Commission to conduct additional feasibility studies and to begin the permitting process. Is a detailed breakdown of how those funds will be spent publicly available? Will the studies and permits be exclusively focused on SMBRC's favored alternative? Has any money been set aside to study what could be achieved via any of the other alternatives?

In the unsourced 2006 Goals, Opportunities and Constraints document posted on the project web site, it was acknowledged that "Because the size of the site is limited, it may not be possible to incorporate large enough patches of all historic habitat types to ensure their viability." As such, why hasn't any money been set aside for acquisition of adjacent lands in the Ballona ecosystem?

The web site currently indicates that the restoration project is scheduled to commence in 2012. Does that refer only to the planning and permitting phase, or actual implementation of the plan (i.e. habitat alteration).

In order to make informed decisions, stakeholders should clearly understand the current state of the wetlands and also what specific gains will be realized by a larger scale project that could not also be realized by a smaller scale project. I understand that SMBRC has invested considerable time and effort into establishing baselines with its volunteer monitoring project, but when it comes to pitching the proposed restoration project to the public, I believe that SMBRC's assertions are quite misleading. While I certainly understand the desire to present your preferred approach in the most positive light, I do not believe that this approach is in the public interest.

I do not know which species stand to gain and which stand to lose as a result of the proposed project. I still do not know how different factors such as water quality, wildlife diversity, public recreation and others have been weighted into the decision making criteria. I don't think it is unreasonable to expect

this level of information for such an important project impacting an ecosystem that took decades to protect.

If the present levee is removed, the need for berms/levees for flood control seem to cover almost 30% of our very fragile and limited wetlands. A plan that allows a small amount of salt/fresh water could be allowed into Ballona, but without any of the major bulldozing that the Coastal Conservancy wants to do.

More concerns and items that need further study and discussion include the following:

Study and describe surface fresh water flows and their interaction with surface salt flows.

Study and describe the pollution, clean up, well abandonment, gas infusion and how all of these will be managed in the course of the project.

Study and describe treatment of 303 waters and how that will be used to enhance the project

Study and describe the dynamic nature of the emerging wetlands environment and how it will be sustained over time with natural processes instead of physical intervention. (dredging, detention basin clean out etc.)

Study and describe existing hydrology and hydrological dynamics of of Ballona Creek outflow channel, both for itself and its interaction with the bay, 303 waters, the jetty, and all wetlands flows.

Study and describe the additional regulatory schemes (FEMA, NPDES, Fish and Game, Coastal Conservancy, Impacted waters, Inundation zone, projected sea rise) and their interaction with the proposed project and alternatives.

This area is a Sacred Site of the Tongva Native Americans, who are the indigenous people of the Los Angeles area. They have been living here for 10,000 years. We need to start acknowledging and respecting their culture more.

Playa Vista is dewatering their gas mitigation system and pumping the water to Hyperion. The aquifer under the wetlands is being depleted rather than replenished. This dewatering of the aquifer should be studied and documented. This water is needed for the wetlands to provide habitat for wildlife including migrating birds.

We need more community meetings with Fish and Game and the Army Corps attending so we can communicate and ask questions of them, prior to expenditure of any more public funds.

The animals and plants need to be studied carefully over a period of time. The government should reach out to local citizens who have studied this ecosystem for a long time and can document a long term history of the area.

Under Section 303(d) of the U.S. Clean Water Act, an impaired waterway cannot further pollute another waterway. Therefore Ballona Creek east and west of Lincoln Blvd. cannot be allowed to flow into the wetlands and pollute them. Other than naturally occurring hydration, no freshwater shall be allowed into the wetlands that has not been treated to tertiary levels.

All of the adjacent bodies of water need to be included into the Ballona Wetlands Study Area (BWSA) including, but not limited to, the Marina Del Rey Harbor, Oxford Lagoon, Del Rey Lagoon, Venice Canals, and Santa Monica Bay. There are still quite a bit of wildlife and sea creatures in the Marina area.

From my readings, it is better to reduce pollution with constructed wetlands specifically design for this purpose instead of discharging polluted water directly into a natural wetland. We need to acquire additional land for water treatment – Ballona Creek is too polluted to be directly diverted to the Ballona Wetlands.

Our Ballona Wetlands need to restored/repared over time. The creek was channelized, then the Marina dredge was dumped, yet we have many working ecosystems presently. We need to move slowly to recover water flow functions, If Ballona is bulldozed we will lose the natural envirnments that have evolved. We need SLOW community engaged restoration with experienced, knowledgeable biologists guiding and observing the process. We need to create and retain a mosaic of as many different habitiats as possible.

Thank you and I hope all of my concerns and those of others will enable a gradual restoration of the Ballona Wetlands.

Donna Murray

8734 Wiley Post Avenue

Los Angeles, CA 90045

310 258-9488

[dlmurray47@gmail.com](mailto:dlmurray47@gmail.com)



# Ballona Wetlands Restoration Project

*Advancing ecosystem health. Connecting communities with nature.*

## Comment Card

Name: Susan Roughen

Email: (optional) \_\_\_\_\_

Add me to the mailing list (please provide email or mailing address): \_\_\_\_\_

sroughen7@yahoo.com

Comments/Issues: (Use additional sheets if necessary)

I am concerned about the harm that may be done to the existing habitat. Has there been an intensive study to evaluate the effect on existing species and native plants? I would like to see the least invasive steps taken in the restoration project.

Submit written comments by **October 23, 2012** to:

Mail: Ballona Wetlands Restoration Project

C/O Donna McCormick

1 Ada, Suite 100

Irvine, CA 92618

Email: [Donna.McCormick@icfi.com](mailto:Donna.McCormick@icfi.com)

**\*\*All comments submitted will become part of the Public Record**

Tape Here  
Do Not  
Staple

Fold Here

LOS ANGELES CA 900

22 OCT 2012 PM 3 1

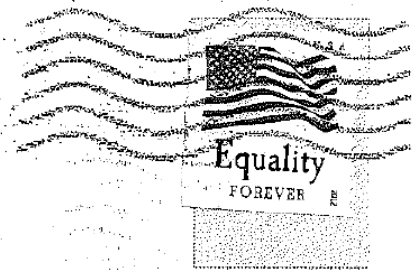

**Ballona Wetlands Restoration Project**  
**C/O Donna McCormick**  
**1 Ada, Suite 100**  
**Irvine, CA 92618**

**Jones, Tanya**

---

**From:** [David.Kay@sce.com](mailto:David.Kay@sce.com) [<mailto:David.Kay@sce.com>]

**Sent:** Monday, October 22, 2012 3:23 PM

**To:** [daniel.p.swenson@usace.army.mil](mailto:daniel.p.swenson@usace.army.mil); McCormick, Donna

**Subject:** Correction: Comments on NOI: (SC No. 2012071090; Docket No. COE-2012-0014) Ballona Wetlands Restoration Project: Friends of Ballona Wetlands

Please note corrected date on the cover letter.

\*\*\*\*\*

David W. Kay

Manager, Environmental Projects  
Southern California Edison Company  
1218 South 5th Avenue  
Monrovia, CA 91016  
626/462-8639

\*\*\*\*\*

----- Forwarded by David Kay/SCE/EIX on 10/22/2012 03:21 PM -----

**From:** David Kay/SCE/EIX  
**To:** [daniel.p.swenson@usace.army.mil](mailto:daniel.p.swenson@usace.army.mil), [DONNA.MCCORMICK@icfi.com](mailto:DONNA.MCCORMICK@icfi.com)  
**Date:** 10/21/2012 05:48 PM  
**Subject:** Comments on NOI: (SC No. 2012071090; Docket No. COE-2012-0014)  
Ballona Wetlands Restoration Project: Friends of Ballona Wetlands

---

Dear Mr. Swenson and Ms. McCormick,

Friends of Ballona Wetlands are pleased to provide the enclosed comments in response to the Notice of Intent (NOI) to prepare a Environmental Impact Report/Environmental Impact Statement (EIR/S) for the Ballona Wetlands Restoration Project.

Friends of Ballona Wetlands ([www.ballonafriends.org](http://www.ballonafriends.org)) is a non-profit 501(c)(3) membership organization with more than 10,000 individuals participating in our education and restoration programs each year. We represent the single largest group of stakeholders participating in the Coastal Conservancy's Ballona Wetlands Restoration Project. FBW has been dedicated to protecting and restoring the Ballona Wetlands for over 30 years with the help of more than 75,000 volunteers, and was instrumental in protecting the Ballona Wetlands from development through designation of the wetlands as a State Ecological Reserve.

If you have any questions, please feel free to call me at 626/462-8639, or Lisa Fimiani at 310/306-5994

Sincerely,

David Kay

[attachment "FBW Letter Ballona NOI 10-21-12.pdf" deleted by David Kay/SCE/EIX]





# Friends of Ballona Wetlands

www.ballonafriends.org

October 21, 2012

Ballona Wetlands Restoration Project  
c/o Donna McCormick  
1 Ada, Suite 100  
Irvine, CA 92816

Dr. Daniel P. Swenson  
U.S. Army Corps of Engineers, Los Angeles District  
P.O. Box 532711  
Los Angeles, CA 90053-2325

RE: Friends of Ballona Wetlands – Comments on the Notice of Intent  
to Prepare a EIR/EIS (SC No. 2012071090; Docket No. COE-  
2012-0014)

## Board of Directors

Dr. David Kay, President  
Dr. James Landry, Vice President  
Lisa Fimiani, Secretary  
John Gregory, Treasurer  
Ruth Lansford, Founder  
Micah Ali  
Paul Costa  
Dr. Pippa Drennan  
Lisa Fimiani  
Susan Gottlieb  
Stephen Groner  
Steve Hirai  
Dr. Edith Read  
Bob Shanman  
Michael Swimmer  
Catherine Tyrrell  
Richard Wegman

## Emeritus Board

Tim Rudnick  
Ed Tarvyd

Dear Ms. McCormick and Mr. Swenson:

Friends of Ballona Wetlands are pleased to provide the enclosed comments in response to the Notice of Intent (NOI) to prepare a Environmental Impact Report/Environmental Impact Statement (EIR/S) for the Ballona Wetlands Restoration Project.

Friends of Ballona Wetlands ([www.ballonafriends.org](http://www.ballonafriends.org)) is a non-profit 501(c)(3) membership organization with more than 10,000 individuals participating in our education and restoration programs each year. We represent the single largest group of stakeholders participating in the Coastal Conservancy's Ballona Wetlands Restoration Project. FBW has been dedicated to protecting and restoring the Ballona Wetlands for over 30 years with the help of more than 75,000 volunteers, and was instrumental in protecting the Ballona Wetlands from development through designation of the wetlands as a State Ecological Reserve.

If you have any questions, please feel free to call me at (310) 306-5994.

Sincerely,

Lisa Fimiani

P.O. Box 5159, Playa del Rey, CA 90296  
phone: 310.306.5994 email: [info@ballonafriends.org](mailto:info@ballonafriends.org)

**Friends of Ballona Wetlands**  
**Comments on Notice of Intent to Prepare a EIR/S**  
**Ballona Wetlands Restoration Project**  
**October 21, 2012**

Friends of Ballona Wetlands (FBW) supports the preparation of an EIR/S for the Ballona Wetlands Restoration Project, and supports a preferred Alternative which includes a comprehensive restoration of most all presently degraded tidelands within the project area. A comprehensive restoration should include a balance of wetland habitats, including subtidal, saltmarsh, mudflat, transitional and upland areas. It must also include elements of well-regulated public access, including ranger patrols, single- and multi-purpose trails, signs and interpretive facilities, rest rooms and trash receptacles. Upland space should be reserved and prepared for a future interpretive center, should one be proposed and funding made available in the future.

The EIR/S should thoroughly analyze the following areas of potential environmental impact from all of the proposed alternatives:

|                          |                                 |                                    |
|--------------------------|---------------------------------|------------------------------------|
| Aesthetics               | Agriculture and Forestry        | Air Quality                        |
| Biological Resources     | Cultural Resources              | Geology/Soils                      |
| Greenhouse Gas Emissions | Hazards and Hazardous Materials | Hydrology/Water Quality            |
| Land Use/Planning        | Mineral Resources               | Noise                              |
| Population/Housing       | Public Services                 | Recreation                         |
| Transportation/Traffic   | Utilities/Service Systems       | Mandatory Findings of Significance |

FBW recommends the EIR/S devote extra discussion and analysis of potential impacts to Cultural Resources. While the areas of proposed project ground disturbance below historical land surface elevations were historically wetland habitat (now filled in by dredge spoils and other fills), the former wetlands area was known to support continuous occupation by native peoples for many thousands of years. Great care must be taken during any proposed excavation and grading to pre-survey, monitor and record any cultural resources encountered and, if necessary, modify project design, engineering and construction as deemed necessary to preserve and protect cultural resources of major significance.

FBW also recommends the EIR focus additional analysis of water quality impacts on the potential of any alternatives to cause temporary or permanent accumulation of urban runoff pollutants in the existing or constructed wetland vegetation or soil. Some investigators have recently hypothesized that maintenance of a permanently open tidal inlet may result in impact to existing or constructed wetland habitat as a result of the presence or accumulation of pollutants within urban runoff carried in the Ballona Creek channel. FBW does not believe such impacts are real or significant, and that modeling of known pollutant concentrations and mass loadings in a “first flush” runoff event in the Ballona Creek channel will support our belief. Owing to improvements in urban runoff quality over the past decade, the short duration of a first flush event and the immediate and repeated flushing of wetland habitat by incoming and outgoing tides, we believe modeling will show no significant impact, due to acute or chronic exposure from or accumulation of urban runoff pollutants, to existing or constructed wetland habitat,

sediments, flora or fauna. Data and means to perform such a mass balance analysis combined with tidal dynamics are readily available and should be employed by the project proponents in order to reject or validate this hypothesis.

In addition, the EIR/S should examine potential impacts of sedimentation at the mouth of Ballona Creek (primarily from littoral drift at the ocean side, not sediment transported by the creek itself) and the extent to which this sedimentation may necessitate periodic inlet dredging. Historically the Ballona wetlands were periodically blocked at the tidal inlet end by sand, so the potential impact of maintaining the Ballona Wetlands as a lagoon system versus an open estuary should be analyzed.

The EIR/S should analyze a reasonable range of project alternatives, including a No Project Alternative. The No Project Alternative should thoroughly examine and analyze as a potential impact the continued degradation of the existing wetlands habitat if no restoration is performed, as well as the loss of various social, economic and watershed values and services.

Furthermore, the EIR/S should analyze a so-called “community alternative” which has been proposed by a few individuals publicly opposed to a comprehensive restoration and opposed to use of any mechanized excavation and grading. Since to our knowledge, none of these individuals have yet to produce a coherent project plan or schedule for such a “community alternative”, even at a conceptual level sufficient to support CEQA or NEPA analysis, the project proponents should therefore themselves design one such “community alternative” and subject it to EIR/S analysis. This so-called “community alternative”, based on repeated verbal and written comments of these individuals in various public forums, would appear to only minimally enhance existing tidal hydrology by hand-constructing tidal channels without the use of mechanized equipment for excavation, grading or material salvage or transport. It would also presumably employ volunteer labor provided by the local community, which should be realistically estimated as part of the analysis.

For a “community alternative”, as with the No Project Alternative, the EIR/S should thoroughly examine and analyze the potential impacts of the continued degradation of the existing wetlands habitat if very slow, minimal, non-mechanized restoration is performed, as the “community alternative” would appear to require, including the loss of various social, economic and watershed values and services by such an approach.

The EIR/S should analyze the possible methods by which a hydrologically functional restoration plan could be constructed without large scale mechanized equipment. These methods could include manual laborers with hand tools, wheelbarrows, and the like, and must also analyze how recontoured or constructed wetland areas could be sufficiently compacted to withstand even common non-flood related land erosion or meet any generally accepted engineering and construction standards. The analysis should consider how public volunteer workers would need to be qualified, trained and equipped to work in compliance with all applicable state and federal health and safety requirements, including being physically fit to perform the required labor. Finally, analysis of a “community alternative” should present possible timelines for completion of various stages of vegetation removal and salvage, land excavation, relocation of utilities and infrastructure, grading and contouring, compacting, and revegetation. The public deserves to

know how many years it would take to fully implement a so-called “community alternative.” The EIR/S should estimate this level of effort, and the impact of wetlands values and services lost over time by such an approach.

For example, one qualified volunteer hand excavating one-quarter cubic yard of material into a wheelbarrow, manually relocating the material by wheelbarrow, then manually placing and recompacting the material using hand-pushed rollers, could be expected to handle 1.25 cubic yards in one 8-hour workday. Fifty such volunteers could move 62.5 cubic yards per day, or 21,875 cubic yards per 350-day work year. The material required to be excavated, relocated and recompacted for a comprehensive restoration of Ballona is conservatively estimated at 1 million cubic yards (based on other restoration projects of similar area size already performed in California). Therefore, it could take 46 years simply to remove, relocate and recompact the material required for a comprehensive restoration at Ballona. Additional labor would be required to remove, salvage, grow and replant wetland vegetation. Such calculations and estimates for a “community alternative” should be included in the EIR/S.

FBW does not believe this so-called “community alternative” will achieve the primary goals of the project; to restore tidal dynamics and habitat in former wetland areas now deeply buried under dredge spoils. However, this alternative should still be analyzed in the EIR/S in order to withstand any future legal challenge based on a claim that such an alternative was not seriously considered.

The EIR/S should, for all alternatives considered, examine and analyze the potential effects of predicted sea-level rise on the proposed plan, including the proportions of various habitat types expected. For example, the impacts of sea-level rise or flooding on existing dune habitat and species located in the westernmost portion of Area B should be considered for each alternative.

The Ballona Wetlands Ecological Reserve (BWER) is 600 acres, surrounded by urban Los Angeles County. The BWER provides valuable and scenic open space in the heart of congested Los Angeles County and offers one of the largest and most promising opportunities for coastal wetland restoration in the region. When restored and opened to the public, the site will allow millions of residents and visitors a rare opportunity to experience a coastal wetland.

Given the location of the Ballona Wetlands and surrounding open space in an urban environment, the biggest challenge is finding the “right” balance between competing needs for salt marsh, freshwater cleansing marsh, uplands, trails and public use. The FBW’s guiding principles are as follows:

1. Restore a wetland ecosystem that functions according to natural estuary flows as much as possible.
2. Respect and enhance existing rich and productive habitats, minimizing disturbances.
3. Maximize the areas available to restore tidal marshes.
4. Minimize disturbance or removal of existing features (such as roads, gas and oil facilities and pipelines, and other expensive infrastructure) when their removal or disturbance would be too expensive, too impractical, or too disruptive.

5. Create opportunities to educate the public about the values of Ballona, teaching them to respect the boundaries of wildlife habitat and enjoy the wetlands without harming them.

With these guiding principles in mind, the FBW overall goals are:

- Restore a dynamic, self-sustaining tidal wetlands ecosystem that results in a net gain in wetlands functions and a net gain in salt marsh acreage and that serves as an estuarine link between Santa Monica Bay and the freshwater tributaries to the Ballona Salt Marsh.
- Maintain flexibility after restoration is complete to allow for adjustments that occur naturally.
- The preferred salt marsh restoration program is a combination of muted tidal where wetlands are currently relatively healthy and functioning (western end south of the channel), and full tidal further inland where it will be least likely to impact existing infrastructure and/or cause flooding. Existing infrastructure forms a divider between these two tidal regimes.
- The new restoration plan is also a unique opportunity to remove at least some existing concrete/rip-rap banks of the Ballona Creek creating a wider and more natural estuarine environment for the Creek.

For non-wetlands open space, the goal is to create additional salt marsh where feasible and to provide improved uplands and prairie grasslands habitat to support a healthy Ballona ecosystem. While restoring uplands vegetation is also important, there is minimal land available for salt marsh restoration and that should be the priority. However existing unique habitat areas, such as the remnant dunes and riparian area at the base of the southern bluffs, should be protected and restored.

- The existing freshwater marsh should be protected, and additional freshwater treatment wetlands be created to protect the salt marsh habitat from upstream urban drainage and pollution and provide a freshwater source for wildlife.
- Public recreational uses, similar to those planned at the Los Angeles State Historic park, most recently known as the Cornfields property near downtown Los Angeles, should be retained at the existing ball fields and in adjacent open space where existing habitat is poor, in order to serve the recreational needs of the children living in surrounding communities, particularly disadvantaged communities.
- Generally, however, emphasis should be on passive recreational uses, such as nature trails or a demonstration garden for native plants, as opposed to more ball fields or active recreation. Such land use should be sensitive to special status species which are known to occur on the site (e.g., southern tarplant) or which may be discovered in surveys.
- Public trails that encourage enjoyment and education regarding Ballona's valuable natural resources and link to existing or planned visitor nodes--- without impacting habitat -- are also important and need to be included. A visitor or interpretive center, conceptually, should also be considered and analyzed as part of the proposed project.

- In order to accomplish the most restoration with limited public dollars, existing constraints should be analyzed and, if possible, accommodated in the restoration design.

Additionally, the following objectives are important for the restoration effort and should be considered:

**Biological:**

- To create a diverse, integrated salt marsh system that provides habitat for native coastal estuarine fish, invertebrates, and wildlife.
- To create freshwater marsh areas which enhance habitat diversity at Ballona and improve water quality.
- To provide a mix of habitat types for sensitive, rare, and endangered species, and species that are of regional conservation concern.
- To contribute to the health of Santa Monica Bay and its watershed, including the diversity and abundance of fish, invertebrates, wildlife, and habitat linkages.
- To restore as much as possible the native plant diversity that had been present historically in the Ballona Wetlands.
- To allow for a brackish ecotone between the existing freshwater marsh and the to-be-restored salt marsh.
- To create, where feasible, sufficient and adequate native upland buffers that aid in maintaining and/or restoring resources and serving as a biological link to the adjacent wetlands.
- As part of native upland buffers, to enhance and create where possible, native coastal prairie habitat – a habitat that is both extremely rare and historically relevant to the region.

**Water Quantity:**

- To protect existing communities and facilities from flooding.
- To allow for seasonal freshwater flushing of the saltwater system that considers interannual variability, natural estuarine dynamics, and the ecology of estuarine species.
- To provide sufficient capacity in water control structures to maintain tidal flushing as the new salt marsh plantings mature and consume more space.

**Water Quality:**

- To assure seasonal fluctuations in salinities to promote salt marsh species diversity.
- To minimize pollutant input from urban runoff into the salt marsh and Santa Monica Bay.
- To protect the wetlands system from accidental spills and trash.

**Soils and Sedimentation:**

- To allow natural accretion of sediment or create elevational contours with the wetland to accommodate sea-level changes.
- To maintain soil moisture and salinity at appropriate levels for the types of salt marsh vegetation desired.
- To remove contaminated or hazardous soils from the site, if present, prior to construction.

**Public Access:**

- To allow limited, well-regulated but effective public access in order to provide meaningful opportunities for the public to experience Ballona while protecting and preserving sensitive species and habitats.
- To provide cohesive trail connections between the Ballona Discovery Park, freshwater marsh, salt marsh, dunes, Ballona Creek, and the Bluffs.
- Employ safe bicycle and walking trails that do not put pedestrians and cyclists on busy streets.
- Safety on Trails: Call boxes, doggie poop bags, and trash cans should be located periodically on trails. There should be no additional lighting.
- Controlled and sensible: Use perimeters and existing trails when possible. Use vistas and clearly designated trails. Use existing bluffs road (Cabora), possible gas company easement and limited new trails, to link a Visitor Center, Discovery Park, and the Freshwater Marsh to Playa del Rey. Limited trails allowing for on-leash dog walking.
- Use raised look-out towers or platforms for viewing and nature study without disturbing wildlife.
- Educational: Signage should explain the history, value, and scenic beauty of Ballona, encouraging stewardship and limiting negative human impact.

**Public Programs:**

- To continue on-site education programs to offer valuable education and restoration opportunities to students of all ages, as well as to the general public.
- To allow current volunteer restoration programs to continue in the dunes and in specific permitted areas throughout Ballona.
- To enhance educational opportunities at the Freshwater Marsh.
- To provide cohesive, connected educational opportunities and signage between the Ballona freshwater marsh, salt marsh, dunes, Ballona creek, and bluffs.

Friends of Ballona Wetlands have long advocated its conceptual restoration plan, which is attached, to represent the general comprehensive restoration of Ballona and the physical and biological elements contained within. This plan is not meant as a design, engineering or construction plan; only as a visual representation of the types of habitat that a restoration project should consider, and the locations where FBW believes such habitats could be restored. FBW appreciates the project proponents' consideration of this plan.

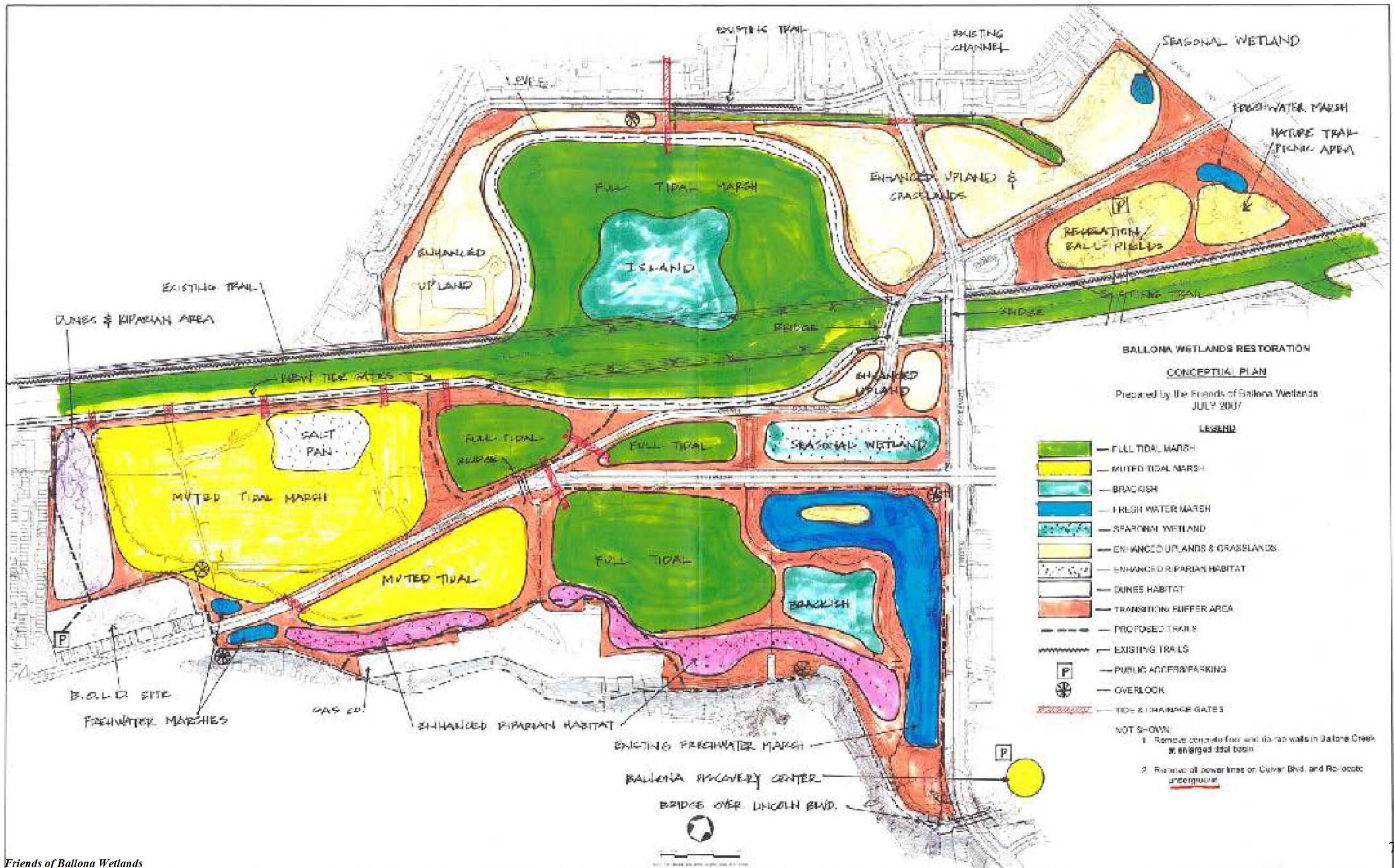

**BALLOMA WETLANDS RESTORATION**  
**CONCEPTUAL PLAN**  
 Prepared by the Friends of Ballona Wetlands  
 JULY 2007

- LEGEND**
- FULL TIDAL MARSH
  - MUTED TIDAL MARSH
  - BRACKISH
  - FRESH WATER MARSH
  - SEASONAL WETLAND
  - ENHANCED UPLANDS & GRASSLANDS
  - ENHANCED RIPARIAN HABITAT
  - DUNES HABITAT
  - TRANSITION BUFFER AREA
  - PROPOSED TRAILS
  - EXISTING TRAILS
  - P PUBLIC ACCESS/PARKING
  - O OVERLOOK
  - TIDE & DRAINAGE GATES
- NOT SHOWN:**
1. Remove concrete foot and dike walls in Ballona Creek at enlarged tidal basin
  2. Relocate all power lines on Culver Blvd. and Relocate underground



Oct. 22, 2012

TO: USACE, Daniel.P.Swenson @ USACE.ARMY.MIL  
CDFG David Lawhead

FROM: GRASSROOTS COALITION, Patricia McPherson-President  
3749 Greenwood Ave. Los Angeles, CA. 90066  
PatriciaMcPherson1@verizon.net

*Please extend the Oct. 23rd NOI deadline until a public hearing by the Army Corps and CDFG can be held. This request was made at the August display event, but thus far it has not happened.*

**RE: SCOPING COMMENTS AND QUERIES FOR THE 2012 NOI; JOINT EIS (CWA PERMITS) AND EIR FOR BALLONA WETLANDS RESTORATION PROJECT**

**ISSUE # 1:**

**OILFIELD GAS HAZARDS/ SOCALGAS/PLAYA VISTA/ WILDLIFE AND PUBLIC HAZARDS**

**SCOPING** - High pressure gas storage operations of the Southern California Gas Company (SOCALGAS) operated within the partially depleted oil fields of Playa del Rey and Venice. New information is available that has not been utilized.

-needs to include studies that evaluate environmental harm from Ballona Channel changes (408 permit ) and dredging/ filling of Ballona habitat pertaining to oilfield gas migration hazards and oilfield gas migration hazards that may be enhanced due to the SMBRC/COASTAL CONSERVANCY (CC) "PLAN"

**Background and overarching scoping needs-**

The promised hydrology studies (2005 Joint EIR/EIS—between USACE & the Authority ) of Ballona Wetlands have not been done. Instead, the SMBRC/FOUNDATION -director & staff and the California Coastal Conservancy have interfered with and stopped the areawide ecological studies and geotechnical studies of the federal review for restoration potentials in the greater Ballona region in order to promote a singular 'Plan' of destruction and experimental construction upon Ballona Wetlands- Areas A,B,C. This "Plan" excluded groundwater hydrology studies and focused upon hydrolics studies of surface water flows into Ballona Channel .

Conservancy contracted- Psomas Co. contour maps of the “Plan” reveal that it is a flood control plan that only benefits a private development known as Playa Vista (Playa Capital LLC). The Proposition 12 bond funds have illegitimately been spent on private use protections to a development site that was illegally allowed to build in a flood plain. FEMA was not engaged for oversight comments as needed as the EIR process for Playa Vista was thwarted by failure to utilize the Clearinghouse as a gateway for proper notice to all pertinent agencies. ( ETINA v City of LA; Playa Capital LLC) This failure by the lead agency- the City of Los Angeles- to include and enforce California Environmental Quality Act (CEQA) protocol of Clearinghouse utilization **PLACES THAT BURDEN NOW UPON USACE AND THE California Dept. of Fish and Game and its state agency partners. FEMA MUST NOW BE ENGAGED** and the issues that pertain to flood protection for Playa Vista must now be reviewed in light of the flood control devices and the preordained ‘Plan’ of development and construction proposed by SMBRC/Foundation and the California Coastal Conservancy.

The giant berms and levees-approximately 20 feet above current road level as shown in the contour plans – are NOT habitat; are NOT RESTORATION but instead are civil works flood protection devices to benefit Playa Vista.

Furthermore, the ‘Plan’s’ intent to DREDGE Ballona is NOT RESTORATION but instead is simply an experimental attempt at an end of pipe solution to the toxic water and sediment flow down the Ballona Channel. The catch-basin shown in the ‘Plan’ does NOT enhance or restore Ballona but instead destroys the very habitat that the public has spent over 20 years to protect. The effects of the ‘Plan’ as a catch-basin and flood control project have not been studied. Current roadways, Marina del Rey and other beach front areas appear to be put in jeopardy from the project.

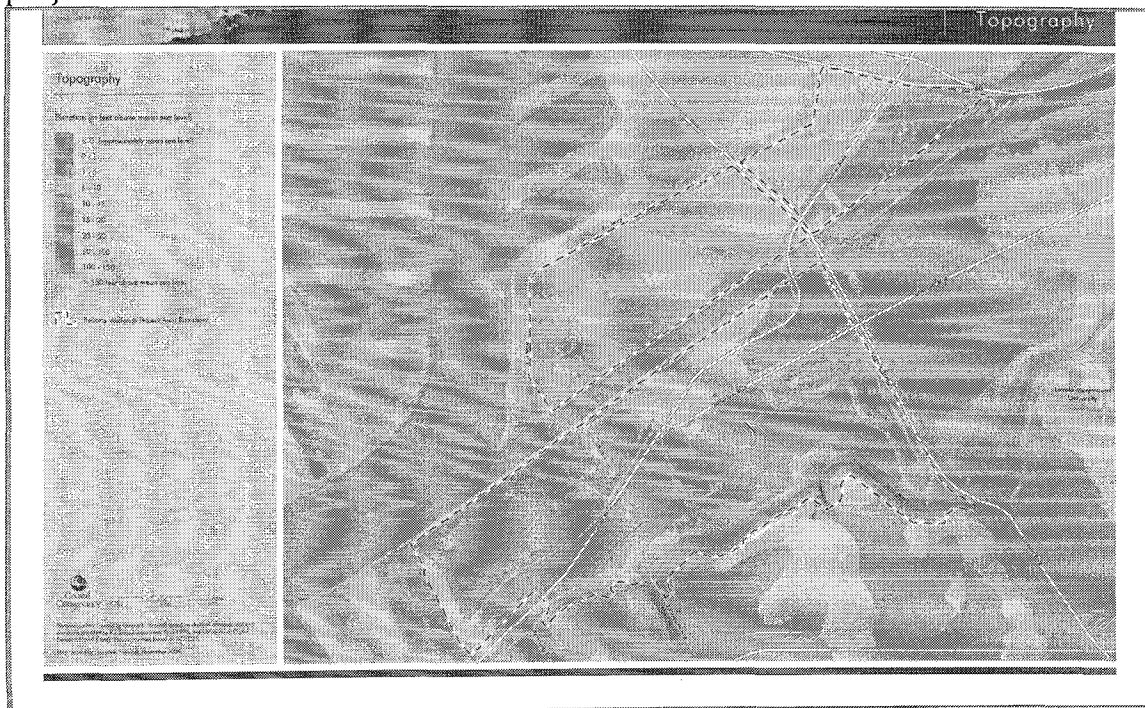

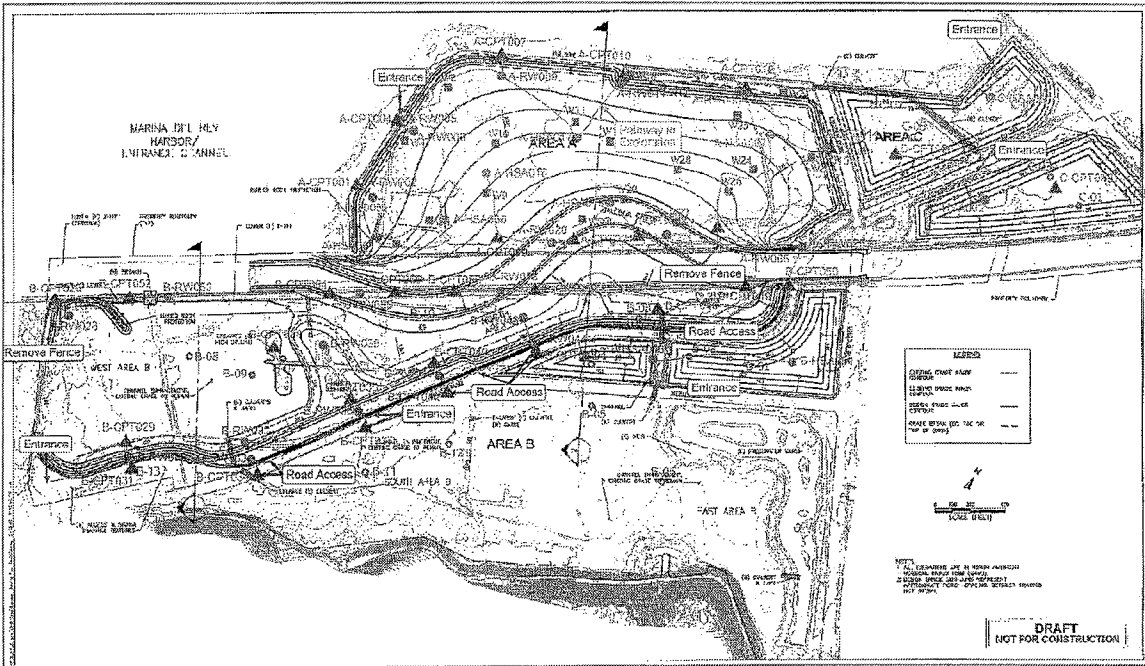
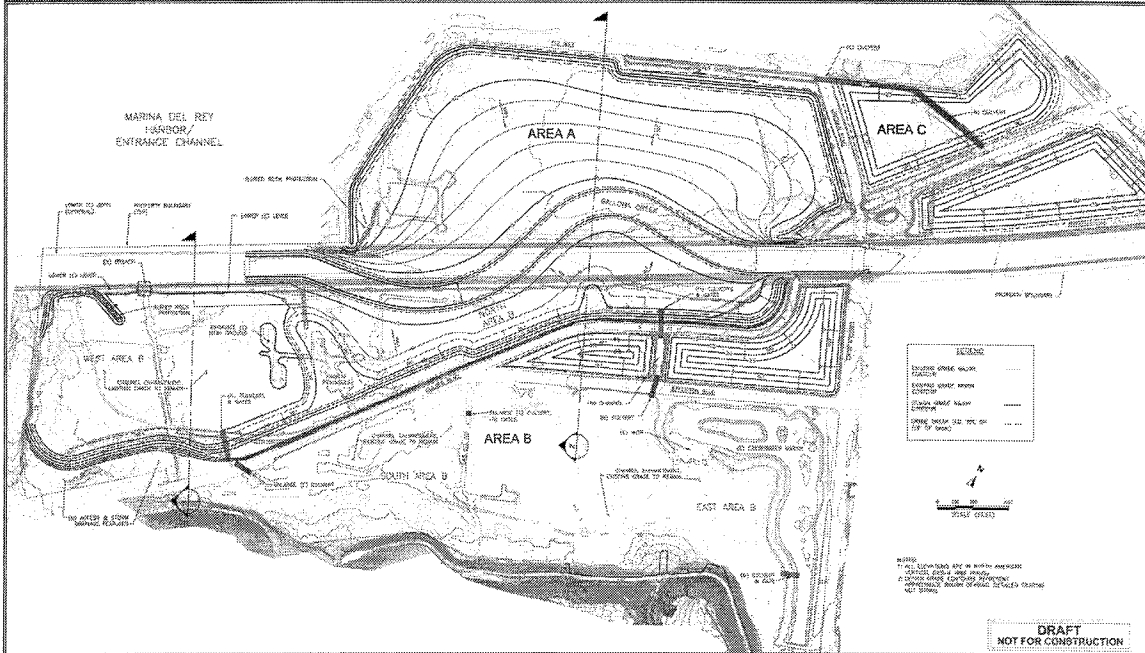

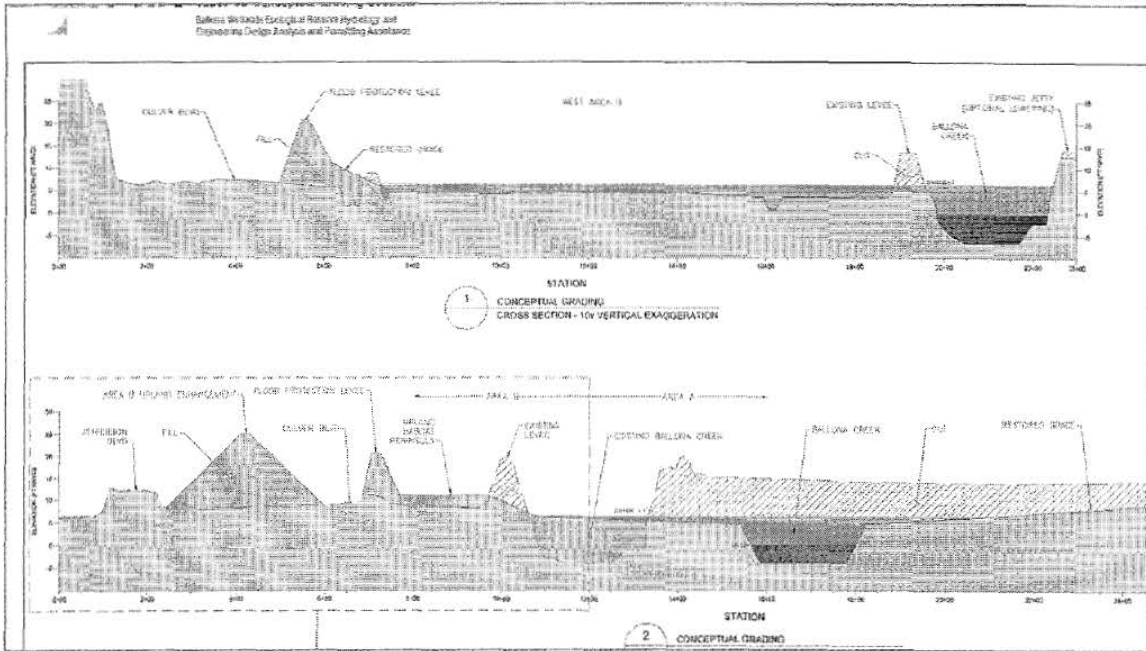

State 'Plan" –note the structural pyramids of berm/ levee and respond to how structures will be 'habitat'? Please include response for nearly vertical levee structures and how is this habitat? Or habitat protection?



**View destroyed towards SM Bay AND height of NON-"restoration upland"- aka engineered flood control berm to protect Playa Vista –GC approximate visual**

**SCOPING:**

Issues of safety, failure to utilize the bond funds as approved by the public; failure to work with and include the public's participation in restoration concepts and planning; the legitimacy of process -- promised and paid for by bond dollars v the exclusionary and preordained outcome plan by the SMBRC/Foundation and the Coastal Conservancy must be addressed in the SCOPING AND DRAFT EIS/R.

Response to conflict of interest allegations, illegal use of bond funds, lack of transparency issues raised and failure to perform in good faith toward restoration, acquisition of more of Ballona, and enhancement issues that would protect and utilize the freshwater resources of Ballona onsite must be addressed and raised for public awareness of these and other challenges leveled at the lead agencies and their 'partner' agencies.

**SOCALGAS – Playa del Rey operations have not been adequately addressed. Migration of oilfield gas issues have not been addressed.**

For example:

*"GROUNDWATER MOVEMENT*

*The movement of local groundwater can greatly influence both the upward and lateral migration of the oilfield gases. For these reasons, a detailed hydrogeological study of the area is necessary. For purposes of environmental assessment, groundwater influences are crucial in the evaluation and interpretation of the experimental data.*

*For example, many of the environmental studies to evaluate soil contamination are carried out using relatively shallow soil probes that do NOT penetrate below the near surface aquifer zones. Accordingly, before proper experimental interpretations can be given to the gas concentrations, **the hydrogeological conditions must be well known. A profound example, is where the aquifer conditions are being continually influenced by the nearby tidal forces of the Pacific Ocean.***

*Furthermore, each of the oil field gas constituents has a different level of solubility in water."p.3*

*BTEX chemicals (benzene, toluene, ethylbenzene, p-xylene, o-xylene) and hydrogen sulfide (H<sub>2</sub>S) are chemicals known to be part of the oilfield gases surfacing in the Ballona Wetlands and Playa Vista. (Exploration Technologies(ETI) / City of Los Angeles 2000-1 gas reports; Still Workin On It – ETI)*

*And per SOCALGAS-PDR operations:*

*"...once upward migrating leaking gases, associated with each well, reaches the gravel zone it rapidly spreads out laterally within the highly permeable gravel zone.*

*The gravel zone extends easterly along the path of the ol Los Angeles Riverbed, and follows the current path of the county flood control channel. In terms of permeability,*

***this gravel zone provides an excellent conduit for the gas to move easterly, and directly under the Playa Vista real estate development currently under construction.***

***This movement has been facilitated by the tidal action of the ocean, which acts as a "piston" (by analogy to an automobile engine) in providing a periodic, and pulsating, energy source in moving the gas from the location of the leaking wells, easterly under the Playa Vista development. At low tide, oil field gas rapidly moves up the old oil field well bores. At high tide the gas is "pushed" easterly as the rising ocean level influences the pressures within the gravel zone." P. 16 ENVIRONMENTAL AND HEALTH HAZARDS DUE TO METHANE AND OTHER OIL FIELD GAS MOVEMENT THROUGH SOILS Bernard Endres, PhD***

Additionally, it is well known that both H<sub>2</sub>S and salt water have proven corrosive effects upon the casings and sealings of well bores. Numerous wells have been identified by SOCALGAS as having holes due to salt water corrosion in the PDR field. (See attachments of internal SOCALGAS documents citing leakage of SOCALGAS wells)

Example:

SCG-Playa del Rey operations:

***"Historical drilling records reveal serious problems with achieving a competent cement seal when the surface casing was being cemented to the surrounding rock formation. This was especially serious for the Townlot Wells that were closer to the Pacific Ocean beach. ....Furthermore, saltwater intrusion from the nearby Pacific Ocean is also highly corrosive to the steel surface casing, and is known to cause significant deterioration of the concrete shoe materials."***

CPUC LITIGATION Grassroots Coalition v SOCALGAS/ Bernard Endres PhD  
consulting expert of record

The Playa del Rey Gas Storage Facility Gas Migration Hazards; And The Duties Imposed To Monitor And Mitigate These Dangerous Conditions Mar. 24,2007  
Case 00-05-010; 011;012



The area is just across from Playa Vista on west side of Lincoln Blvd. Note the tire tracks and site vacated after exposing gas and fluids broiling up in closeup provided below. Why wasn't this borehole and effluent contained? This wetland portion filled with pickleweed- a wetland indicator species- will be destroyed by the State's Plan by filling up to 20' above road level in order to create what? A giant flood control mountain of vertical earth. The public paid for Ballona to be restored and enhanced ---not to use public dollars to provide private protection to Playa Vista. Please respond.

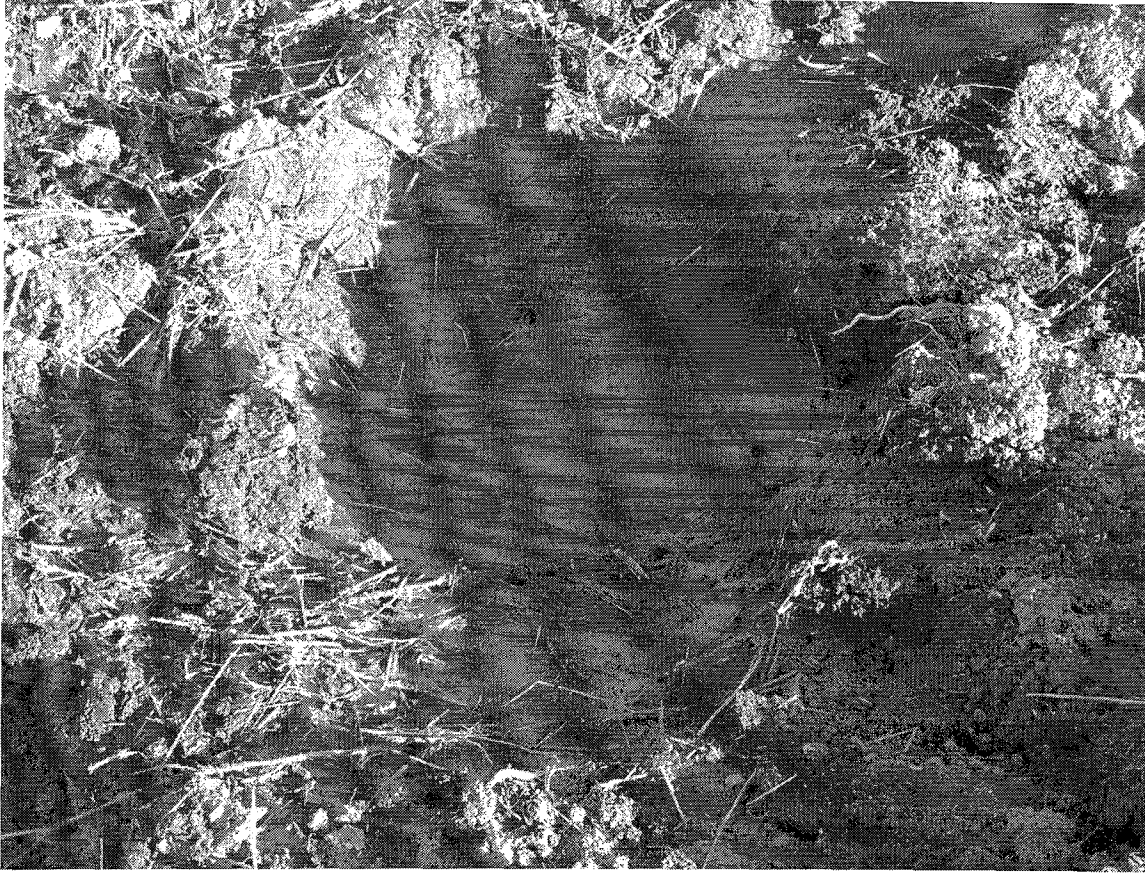

Image reveals recent borings left to broil up with oil and gases. Please provide discussion/ explanation/ testing data of this boring along with the rest of the boring done on Ballona in 2012.

**SCOPING-** Studies need to include evaluations of how monitoring will occur for gas leakage and contamination, where and what mitigation will need to occur regarding oil/gas wells or other wells acting as conduits for oilfield gas migration.

- Who will be responsible for enhanced gas migration throughout the area due to the construction of the catch-basin (treatment wetland) and flood control protection to Playa Vista of the berms and levees ?
- -What mitigation will take place to prevent enhanced gas movement through the area due to the proposed tidal inundation and flows?
- What studies will be done to illuminate the potential gas movement changes?
- How and what mitigation measures will offset the enhanced liquefaction potentials caused by gas migration upon the proposed levees, berms and other construction devices of the channel changes and proposed experimental treatment basin?
- What liabilities and responsibilities do the state agencies including CDFG ; the Coastal Conservancy (CC); Santa Monica Bay Restoration Commission (SMBRC) and its individual personnel and the USACE have



for affects upon the infrastructure and the environment for failure to evaluate the gas migration pathways?

- Evaluation needs to take place -
- How will the proposed channel change/ berm and levee construction and dredging and increased tidal flow facilitate the migration of oilfield gases and dangerous accumulation of these gases—especially in light of the current failure to investigate and/or monitor at least one Playa Capital LLC oilwell- University City Syndicate (freshwater marsh) that is off gassing millions of cubic feet of oilfield gases daily and numerous other SOCALGAS wells that have recently leaked reservoir gases to the surface?(DOGGR 1008 Order & SOCALGAS/ Grassroots Coalition Settlement Agreement gas studies showing 900,000 ppm of oilfield gases surfacing)
- Since the riparian corridor and the catchbasin (freshwater marsh) are also part of the Ballona ecosystem and directly and/or indirectly affects the region via gas contamination and/or other contamination—what liabilities do the agencies of the EIR/EIS have for failure to include and address the overlapping environmental issues and their mitigation?
- The Playa Vista site- including the riparian corridor and the catch basin (freshwater marsh) need to be included in the EIS/EIR for the issues of gas migration/mitigation ; dewatering-hydrology as the areas directly and indirectly affect the region.
- Playa Vista was built in a flood plain without oversight -via CEQA clearinghouse notification- of FEMA. (ETINA v City of LA/Playa Capital LLC) Scoping now needs to include these issues of buildout in a flood plain and the ramifications of that buildout.
- 

**SCOPING-** Gas migration evaluations need to be performed throughout the restoration area to update and map current oilfield gas migration patterns. The joint EIR/EIS must include available information pertaining to the oilfield gas migration hazards of Ballona.

-What soil gas and hydrology issues were discovered in 2012 as a result of the boring operations for berm and levee placement ?

- What geotechnical issues regarding the gravel zone and other underlying zones and aquifers were addressed and acknowledged as part of the same boring operations? These issues and scientifically legitimate answers by qualified and UNBIASED scientists must be included as part of the scoping issues.

- It appears that most if not all of the consultants utilized for work studies on Ballona have a lengthy and conflicted history of working for the Playa Vista, Playa Capital LLC; SOCALGAS- SOCALEdison (affiliated with SOCALGAS via gas storage needs and contracts) entities that have vested and monetary interests in Ballona both directly and indirectly.

**- Why does the federal government and state agencies allow for such apparent conflict of interest to occur?**

**-Why aren't companies without such past and current financial ties to the Playa Vista development site and SOCALGAS/Edison being contracted for work on Ballona by the federal government and state agencies??**

**See-** California Public Utilities Commission (CPUC)- Safety Branch Report citing the high likelihood of SOCALGAS reservoir gas leaking to the surface throughout Ballona and Playa Vista. The Nov. 2004 Consumer Protection and Safety Division report cites major concerns for SOCALGAS reservoir gas leakage:

*"C. 22 PPM. Helium from a shallow probe sample by John Sepich and Associate. Isotech Laboratory performed an isotopic analysis of a gas sample submitted by Sepich & Associates on 3/25/99. Sepich and Associates was working for Playa Vista developers (developers of residential and business properties around the PDR Storage field. The isotopic analysis report indicates the gas sample was collected from Playa Vista Project Area -D. The analysis report also revealed presence of Ethane and 22 PPM Helium in the gas sample. The significance of this isotopic analysis report is the presence Storage Reservoir gas or Native PDR gas signature and the location where the gas sample was collect (Area—D of Playa Vista Project)."*

*"My opinion is that the probability of Storage Reservoir gas sample from PDR area containing Ethane and 22 PPM Helium is greater than 50 percent (>50%). Furthermore, the location where the sample was collected should be of major concern. Please see Appendix # C." p.6.*

### *"III. Recommendations*

*A review of the aforementioned facts and findings suggest the existence of a potential safety hazard." P.9*

The report recommends further study and investigation on pages 9-10 that includes but are not limited to :

*3-dimensional geologic computer model that provides "(well records, soil gas investigations, geo-technical borings, geophysical data, environmental borings, site contamination data, groundwater data, etc) to fully integrate and visually display geologic data 9strata and discontinuities) and other subsurface information (gas and groundwater locations) at the storage field."pg. 9*

**SCOPING-**These studies have not been performed and should be part of the scoping review for the federal and state review of Ballona.

Because of the vested financial interests of Playa Vista (Playa Capital LLC) and SOCALGAS and SOCAL Edison (gas storage use of PDR field) ; Grassroots Coalition

believes that only contractors with no conflicted financial ties to these corporate entities should be allowed to perform geotechnical and environmental studies upon the Ballona region in order to perform unbiased studies.

GC is also concerned about the financial and conflicted interests of staff and board members of SMBRFoundation who provide direct and indirect influence upon both the SMBRC and the Coastal Conservancy.

**SCOPING-** Transparency does not exist in the Ballona restoration process and needs to be included in the scoping issues for the DEIR. Full public disclosure of the financial and economic issues must be addressed and addressed individually for all staff and board members of the private SMBRFoundation—including those that simultaneously hold positions of authority within the SMBRC, the Coastal Conservancy, other state or federal agencies.

Concerns regarding use of bond funds for the ‘SMBRProject’ which in 2002 became the SMBRCCommission. The SMBRFOUNDATION claims in IRS documents that IT IS THE PROJECT. Thus, the SMBRFoundation takes in funding that is cited as being given to the SMBRC.

- Therefore, it is important for public awareness and participation for both the USACE and CDFG to address and make clear to the public---who actually is legally able contractually to receive and spend federal and state funds which are derived from the public.

-Conflict of interest issues must be addressed specifically by the USACE and CDFG that are responsive to specific queries raised by the public—including but not limited to the John Davis March 28, 2012 -REQUEST TO HOLD EMERGENCY MEETING TO RESCIND APPROVAL ACTION ON FILE NO. 04-088 ; the GC Amended Complaint to the Ca. Coastal Conservancy of August 2, 2012. Neither of these documents has had any response from the lead agencies partner—the Ca. Coastal Conservancy. The public has a right to know in order to make informed decisions.

See- 1008 Order -Division of Oil and Gas and Geothermal Resources (DOGGR) 2011 DOGGR 2011 Order for shut down of SOCALGAS gas injection operations pending investigation and control of escaping and surfacing reservoir gases. The escaping reservoir gases utilized relatively new wells of SOCALGAS/PDR operations.

See- SETTLEMENT AGREEMENT (CPUC litigation Grassroots Coalition v SOCALGAS)

**SCOPING -The EIS/EIR should contain information relative to the ongoing status of the SA.**

Health and safety issues are critical to restoration of Ballona. SOCALGAS has not abided by the terms of the SA and GC has been working to ensure...

See-

The 2005 EIS/EIR scoping included the potential and likely negative environmental effects of eg. Poland Report issues identified by USACE in the construction of the Marina del Rey marina such as potential negative effects to the groundwater (classified as potential drinking water) due to breaching clay layers from dredging the marina areas. The USACE cited likely salt water intrusion enhancement and needs for protection of freshwater from salt water contamination. The Poland Report cites the connection of the Ballona area to the west basin aquifer.

**SCOPING-** The 2012 EIS/EIR should include the Poland Report and the USACE 2005 EIS (House Document 389) issues raised regarding concerns of Ballona aquifer / West Basin contamination. For instance:

**-what effects will dredging have upon further saltwater contamination in the area.**

**-how will freshwater resources of the area be protected? The House Document 389 cautioned against breaching a clay layer protecting deeper freshwater zones at Ballona.**

**Additionally, clay layers can contain secondary collector zones of oilfield gases.**

**Example- from the Fairfax explosion 1985-Ross-Dress-For-Less.**

The pathway of gas migration to the surface included the 3rd Street Fault and an old abandoned well (Chilingar, personal communication). A shallow collector zone (large pocket) of trapped oilfield gas was discovered at a depth of approximately 15 m with pressures of approximately 1.8 kg/cm<sup>2</sup>. This collector zone had sufficient porosity and permeability to serve as a temporary trap for the large quantities of upward migrating gases. **A clay layer served as a seal until its threshold pressure was exceeded.** After the explosion, permanent soil gas probes were installed to a depth of approximately 4.6 m in order to perform ongoing monitoring of the upward migrating gases

p 1446. 2012 Migration of Gas from Oil /Gas Fields

J. O. Robertson, G.V.Chilingar, L.F. Khilyuk, B. Endrea

**-what mitigation will take place for preservation of the freshwater aquifers and streams?**

**-Freshwater zones must be protected from the invasion of oilfield gas chemicals; alternative restoration concepts must include options that provide absolute protection from exacerbation of oilfield gas migration contamination.**

**-SOCALGAS pipelines have not been acknowledged or addressed. Multiple SCG pipelines that surround and pass through Areas A and B have not had any evaluation and must be considered and mitigated and/or removed to prevent**

**further contamination to the area. (SEE Public Record Act requests to County and Beaches and Harbor)**

- **new directional SCG wells that bottom out under Area A are, according to SCG- being used for fluid injection. What potential for direct or indirect harm to the environment exists now? And, what direct or indirect harm may occur to the environment and ecosystem due to potential fracturing of the formation from the fluid injection? What mitigation is proposed and who will maintain liability for harm to the environment?**

**SCOPING:**

**PLAYA VISTA**—There are numerous issues of potential for harm and diversion of groundwater that Playa Vista development project poses to the restoration of Ballona.

1. Groundwater diversion- see Groundwater Issues. Playa Vista must dewater the groundwater in order to keep gas evacuation pipes free of clogging from silt and water. The groundwater flow is toward the ocean thus any dewatering is depriving the wetlands from that groundwater and diverting water that would recharge the underlying aquifers.  
-The volumes of groundwater diversion and its potential harm to the wetlands has not been performed and needs to be performed.  
The potential for use onsite of Ballona must be part of any restoration analysis for Ballona.

“What is missing is any review of actual data from the Los Angeles Department of Sanitation. There are no Department of Sanitation documents in the Record which show actual or potential permitted groundwater discharges into the City Sewer System.”

. “Impacts of the project must be measured against the real conditions on the ground.” (*Save Our Peninsula Comm. v. Monterey County Bd. of Supervisors* (2001) 87 Cal. App. 4th 99, 121 (citations omitted).) The City cannot simply rely on modeling data provided by Playa Vista, which has a vested interest in downplaying, limiting and minimizing the potential impacts of dewatering. (See *Id.* at 126 (discussing problems with relying solely on applicant generated data).) The City cannot delegate the duty to Playa Vista (or the public) to gather the necessary baseline information. (*Id.* at 122.)

“Petitioners specifically requested the City review its files from the Department of Sanitation in its “Notice of Information Required for Adequate CEQA Review” (5 RR 986.) In addition, a number of comments questioned the lack of actual data from the Department of Sanitation. (See e.g., 2 RR 428; 7 RR 1328; 1357.) In fact, five months before the final decision, Patricia McPherson stated at a public hearing “The Department of Sanitation has 65 - - 65 groundwater dewatering permits for the site

at Playa Vista. You chose five building to look at. You didn't give [the Peer Reviewers] a fair model to begin with." (7 RR 1357:line 24 to 1358: line 3.) The City simply ignored such comment and pretended that the Department of Sanitation did not exist. " page 5 of brief

It is the City's duty, not the public's to do the proper environmental investigation. (*Save Our Peninsula, supra*, 87 Cal. App. 4th at 122; *Sundstrom v. County of Mendocino* (1988) 202 Cal. App. 3d 296, 311.) The City violated the information disclosure provisions of CEQA by not providing records from the Department of Sanitation to the City Council and the public for review.

**C. The City Abused Its Discretion By Failing to Inform the Regional Water Quality Control Board of its CEQA Review and Gathering the Appropriate Data.**

Informing other governmental agencies that CEQA review is occurring is an incredibly important step in the CEQA process. Section 21080.3 of CEQA states:

Prior to determining whether a negative declaration or environmental impact report is required for a project, the lead agency shall consult with all responsible agencies and trustee agencies. Prior to that required consultation, the lead agency may informally contact any of those agencies.

(Pub. Res. Code § 21080.3(a).)

Obviously, such consultation will only occur if the responsible or trustee agency that it is informed that it is evaluating a project (or a portion of a project) under CEQA. There is nothing in the record which demonstrates the City informed the Regional Water Quality Control Board (RWQCB) that it was participating in a CEQA process. The failure to inform a lead or trustee agency of the CEQA process is a prejudicial an abuse of discretion. (*Fall River Wild Trout Found. v. County of Shasta* (1999) 70 Cal. App. 4th 482, 492.)

This is not to imply that the RWQCB did not participate in the CLA process. However, the CLA process, according to the City's was not prepared under CEQA. As noted by Attorney Susan Pfann, "There's no requirement of how you about doing [a peer review] or whether or not you have to senditso certain agencies...its simply a study." (2 RR 403.) In this case, the City failed to inform the Regional Water Quality Control Board (RWQCB) of its CEQA process, instead simply requesting the RWQCB simply review Playa Vista's modeling program. Petitioners' specifically objected to the City's failure to notify the RWQCB of the process thereby triggering full CEQA review. (5 RR 943.) By solely requesting a review of the modeling study prepared by CDM, the City prevented the RWQCB from fully participating in a manner

required in a CEQA review process, and violated the information disclosure requirements of CEQA. (Pub. Res. Code 21005.)

The City may argue that its failure to inform the RWQCB that it was participating in a CEQA process was not a prejudicial because the RWQCB did make comments. Perhaps if the City had requested all the relevant data regarding dewater at Playa Vista and Ballona Wetlands possessed by the RWQCB, the City would have an argument. However, there is no evidence in the record that the City requested even basic data, such as NPDES permits or actual metering data, despite the fact that Petitioners specifically requested the City review NPDES permits in its study of significant effects. (5 RR 986.)

**D. The City Failed to Gather or Present Data Necessary for Determining Whether Dewatering Activities Were Cumulatively Considerable.**

The lack of information from the RWQCB and Department of Sanitation is especially egregious when one considers the lack of analysis of cumulative impacts. A lead agency must determine not only direct and indirect effects of a project are significant, but must also consider whether such impacts are cumulatively significant. (Guidelines section 15064.) As noted in the case law discussing cumulative impacts, “the outcome may appear startling once the nature of the cumulative impact problem has been grasped.” (*Kings County Farm Bureau v. City of Hanford* (1990) 221 Cal. App. 3d 692, 721.) The City, by limiting its review solely to the five buildings identified by Playa Vista in its modeling data, failed to consider whether all dewatering activities taken together, may be cumulatively significant.

Phase I of the Playa Vista Development consists of 3,426 residential units, 1.25 million square feet of office and light industrial space, 35,000 acres of retail space and 300 hotel rooms on 246.3 acres of land. ((*Environmentalism Through Inspiration and Non-Violent Action, et. al. v. City of Los Angeles*, 2005 Cal. App. Unpub. LEXIS 9697, at 3.) (“*ETINA v. LA*”) Despite the massive size, there is no description in the 2007 CLA Report of how many buildings are a part of Playa Vista Phase I, nor how many buildings have dewatering systems. This data should have been easily obtainable from

the Department of Sanitation, which issued industrial water permits for the dewatering systems. (3 RR 502.) Yet, it was not presented to the public.

If one were to search exhaustively through the administrative record, one would find a table described as "Construction and Vesting Status of Playa Vista Phase I" that was apparently submitted by Playa Vista on the date of the hearing. (2 RR 226.) The table identifies 39 Buildings in the "west end of the first phase" (2 RR 226-29.) Of those 39 buildings identified by Playa Vista, 18 of such buildings are identified as having "ground-water dewatering system" Yet, the table fails to identify how much dewatering is occurring at each site. Such information is crucial to knowing whether the dewatering at Playa Vista is cumulatively considerable.

In addition, other dewatering activities independent of buildings must be evaluated to determine whether there is a significant impact. It was incumbent on the City to request dewatering data from the RWQCB, the agency responsible for managing the states' water. Despite petitioners' request that such data be evaluated, there is no indication in the record that the City requested such information from the RWQCB. (3 RR 486.)

Of course, as indicated by the description as "Playa Vista Phase I", there is also Playa Vista Phase II. Despite this well-known fact, there is no analysis in the 2007 CLA report of Phase II. The 2007 CLA report indicates that the peer reviewers solely reviewed reports analyzing the potential impacts installed in Phase I of the Playa Vista development. (3 RR 473.) There is no analysis of the dewatering activities expected in Phase II of the Playa Vista Development.

For a proper analysis of the potential cumulative impacts requires an analysis of all dewatering activities at Playa Vista. This information is available from the RWQCB. But, the City failed to request such information. There is not information in the record which describes NPDES permits of the Playa Vista site or actual discharge volumes into Ballona Wetlands. Without providing the total volume of all dewatering activities, neither the City nor the public can properly evaluate or participate in the public process. “



Additional Objections In Opposition To Return To Writ—**ETINA v City of Los Angeles, Playa Capital LLC**

**A. Evidence From the Los Angeles Department of Sanitation and the Regional Water Quality Control Board Demonstrates the City and Playa Vista Violated Information Disclosure Requirements of CEQA.**

Public Resources Code section 21005 states,

[N]oncompliance with the information disclosure provisions of this division which precludes relevant information from being presented to the public agency . . . may constitute a prejudicial abuse of discretion.

There a number of ways that an applicant or a lead agency may fail to comply with the information disclosure requirements. (*See e.g. Fall River Wild Trout Found. v. County of Shasta* (1999) 70 Cal. App. 4th 482, 493 (failing to notify DFG); *Cadiz Land Co. v. Rail Cycle* (2000) 83 Cal. App. 4th 74, 95 (failing to identify size of aquifer); *Sierra Club v. State Bd. of Forestry* (1994) 7 Cal. 4th 1215 (failing to study endangered species); *Save Our Peninsula, supra*, 87 Cal. App. 4th at 122 (failing to use actual data).) In fact, many cases which have sought to strike down environmental impact reports have sought to establish, through omission, that there has been non-compliance with the information disclosure requirements of CEQA. (*Association of Irrigated Residents v. County of Madera* (2003) 107 Cal. App. 4th 1383, 1391.)

However, suppression of evidence is also a form of non-compliance. Evidence which clearly should be in the record, but has been improperly excluded, should be admissible to demonstrate a violation of Public Resources Code section 21005. Clearly evidence which has been withheld from the public, despite requests from the public for inclusion of such information, cannot be provided by the public. In addition, the public should be able to assume the lead agency will include documents which are required to be part of the administrative record under CEQA, such as documents in its own files on a project. (Pub. Res. Code 21167.6(e)(10).)

Such interpretation is supported by *Western States* which notes that extra-record evidence should be admissible to demonstrate procedural unfairness and agency misconduct. (*Western States Petroleum Ass'n v. Superior Court* (1995) 9 Cal. 4th 559, 575 n.5 & 579.) In *Western States*, the petroleum association attempted to introduce newly created expert evidence, prepared after the close of the public hearing, to demonstrate that the Air Resources Board failed to consider all relevant factors. The Supreme Court held, "extra-record evidence can never be admitted merely to contradict the evidence the administrative agency relied on in making a

quasi-legislative decision or to raise a question regarding the wisdom of that decision." In contrast, in this case Petitioners seek the court to consider documents which were in the agency's files or trustee agency's files to demonstrate a procedural defect in the City's CLA process.

In this case, there is extra-record evidence from the Department of Sanitation which demonstrates that the level of dewatering is almost five-fold greater than that which was presented in Playa Vista's modeling study. (Notice of Lodgment, Ex. 1.)<sup>1</sup> Brief pgs 9-10

**SCOPING:**

**-The duty of cumulative groundwater dewatering now falls upon the state and federal agencies in the performance of this NEPA/ CEQA process.**

**- The duty of full disclosure with regard to state and federal agency behavior and process is also required in this NEPA/CEQA process- as cited above in the brief. Thus response to the John Davis and GC Complaints to the COASTAL CONSERVANCY regarding failure of due process, conflict of interest, prejudice - --require full evaluation and response.**

" Still all the cases appear to agree that "[a] prejudicial abuse of discretion occurs if the failure to include relevant information precludes informed decisionmaking and

---

#### **IV. MOTION TO AUGMENT**

##### **A. This Court May Consider Relevant and Improperly Excluded Extra-Record Documents Because Petitioners Have Proven Such Documents Fall Under the Exception Enunciated by the Supreme Court of California.**

Respondents contend that this Court may not consider two sets of relevant, extra-record documents: (1) documents from the LA City Department of Sanitation, including a table showing permitted discharges of up to 72,000 gallons per day, and (2) documents from the RWQCB showing permitted discharges of 950,000 gallons per day ("gpd"). (16 CT 3696-3700.) Though extra-record evidence is generally inadmissible, the Supreme Court of California has enunciated an exception to this general rule. "Extra-record evidence is admissible if the proponent shows that the evidence existed before the agency made its decision, but that it was impossible in the exercise of reasonable diligence to present it to the agency before the decision was made." (See *Cadiz Land Co. v. Rail Cycle* (2000) 83 Cal. App. 4th 74, 119 quoting *Western States Petroleum Assn. v. Superior Court, supra*, 9 Cal. 4th 559, 576-578.) This exception corresponds with Code of Civil Procedure section 1094.5, subdivision (e), which grants the court discretion to remand the case for reconsideration if the court finds "there is relevant evidence, which, in the exercise of reasonable diligence, could not have been produced at the administrative hearing or which was improperly excluded." (CCP § 1094.5.) Also, arguably, "extra-record evidence may be admissible to show 'agency misconduct.'" (*Id.* at 119 quoting *Western States Petroleum Assn., supra*, 9 Cal. 4th at pp. 575-576, fn. 5.)

The Court may properly consider the extra-record documents at issue

informed public participation, thereby thwarting the statutory goals of the EIR process." (*Id.*; *See also, Save Our Peninsula Comm. v. Monterey County Bd. of Supervisors* (2001) 87 Cal. App. 4th 99, 118; *Sierra Club v. State Bd. of Forestry* (1994) 7 Cal. 4th 1215; 1235.) "The courts have looked not for perfection but for adequacy, completeness, and a good faith effort at full disclosure" (*County of Amador, supra*, 76 Cal. App. 4th at 954.) " Brief p. 3

here because the documents demonstrate the City failed to consider maximum permitted discharges, even though such documents were in existence prior to the City's decision. Maximum permitted discharges are relevant both to an analysis of cumulative impacts, and to an analysis of potential worst-case scenario impacts for methane dewatering. Though Petitioners exercised reasonable diligence in requesting access to and inclusion of these documents, the City failed to comply. (Code Civ. Proc. § 1094.5(e).) This failure to include or consider these documents amounts to suppression of evidence and agency misconduct. Accordingly, the extra-record documents at issue here fall under the narrow exception articulated in *Western States* and Code of Civil Procedure section 1094.5(e). (*Western States Petroleum Assoc. v. Superior Court* (1995) 9 Cal. 4th 559, 576-578.)

**i. The Record of Proceedings Under Public Resources Code Section 21167.6(a) is Broad and Inclusive.**

Pursuant to Public Resources Code Section 21167.6(a), the record of proceedings shall include a broad array of documents "relating to the subject of the action or proceeding." Public Resources Code Section 21167.6(e) is inclusive, providing a list of items that "shall be included," but specifying that the record "is not limited to" those items. The statute "contemplates that the administrative record will include pretty much everything that ever came near a proposed development or to the agency's compliance with CEQA in responding to that development." (*County of Orange v. Superior Court* (2003) 113 Cal. App. 4th 1, 10.)

JOINT REPLY BRIEF- ETINA et al Appellate District Case No. B213967

2. **The 2007 Methane Mitigation AUDIT performed by the City of Los Angeles (City Controller- Laura Chick) needs to be included and analyzed** for determination of the effects of the gas mitigation dewatering. The AUDIT reveals that methane mitigation measures –including the critical 50' deep vent wells (that but for their ability to vent and not clog—the site was considered too dangerous to build (CLA Report)— Had no mitigation monitoring and no proof that the systems were implanted or implemented in a fashion that they actually work. The Audit also shows that Playa Capital LLC and the City of LA were and are unable to identify where the 50' vent wells are.

3. Department of Sanitation records need to be evaluated for analysis of groundwater dewatering that has direct and indirect impacts upon the restoration of Ballona and current groundwater movement across the Ballona habitat.
- Playa Vista and the City of LA have irresponsibly failed to provide Best Management Practices for the groundwater of Playa Vista and thus upon the sensitive ecological areas of Ballona. Instead, Playa Vista has been improperly and potentially illegally allowed to discharge Ballona groundwater (classified as potential drinking water) into the Sanitary Sewer via WASTEWATER DISCHARGE APPLICATIONS AND SOME PERMITS.

4. **GRAVEL COLLUMNS:**

No 408 permits were given to Playa Capital LLC for installation of hundreds of gravel collumns along Ballona Channel- the north side of Fountain Park Apts.

-This 408 permit issue needs to be evaluated for potential illegalities of insertion of the gravel collumns- without permitting as well as evaluated for The known and established actions of the stone collumns to act as cross contamination and groundwater movement features for groundwater and gases.

-GC supplied pictures to the City of Los Angeles and to the LA County Flood Control that depicted CRACKING along Ballona's south levee- on the north side of Fountain Park Apts. GC herein submits a video- BURNING QUESTIONS- that supplies video of the insertion process of those stone collumns and the apparent outgassing and vibration.

- What effects do the collumns have upon the integrity of the Ballona levee to the east of Lincoln Blvd.?

- Did Playa Capital LLC have to secure a 408 permit for insertion of the stone collumns since the collumns align along the fence line of the Ballona levee? And, potentially have the ability to undermine the earth of the levee itself due to the constant rise and fall of tidal action upon the ground waters?

-The City of Los Angeles and County Flood Control only performed a visual inspection as was discussed during a Building and Safety Commission Hearing during the 2000 -1 timeframe. To GC's knowledge no alert was provided to the Army Corps of Engineers for input into this issue of present concern. The collumns while providing stability from liquefaction for the apartment complex appear to be potentially undermining the integrity of the Ballona levee to the east of Lincoln Blvd.

5. **CDFG HISTORIC LACK OF OVERSIGHT OF KEY HEALTH AND SAFETY ENVIRONMENTAL ISSUES THAT CDFG must address in the 2012 EIS/EIR;**

Including its role or lack thereof of prudent oversight of health and safety issues.

Example of why clarification is needed- this GC letter to CDFG from 2003:

September 4, 2003

TO: THE CALIFORNIA DEPARTMENT OF FISH & GAME-  
Mr. Raisbrook, Regional Manager  
San Diego, California fx 858 467 4201

FROM: GRASSROOTS COALITION-  
Patricia McPherson

**RE: ECOLOGICAL ASSESSMENT OF AREAS B AND D- PLAYA VISTA, 6775  
CENTINELA AVENUE, LOS ANGELES, CALIFORNIA &**

**PHASE 2 EIR- PLAYA VISTA**

Dear Mr. Raisbrook,

**Grassroots Coalition respectfully requests that the California Department of Fish & Game clarify, in writing, its scope of review and involvement regarding the Playa Vista site.**

The EIR for the Playa Vista Phase 2 is now available for review, as I am sure that you are aware. Also, the Los Angeles Regional Water Quality Control Board (LARWQCB) sent Grassroots an Ecological Assessment (EA) of Areas B and D of the Playa Vista site for review. The deadline for comments was mid-August. I have included the LARWQCB letter with its cc list. Grassroots did respond but also notified various Fish & Game personnel, including Brad Henderson- our local CA. Dept. of Fish & Game (DFG) biologist, of the EA. In my comments to the LARWQCB, I noted that DFG had not been given the EA. Apparently, the LARWQCB has now sent the EA to DFG and given the DFG a September 15, 2003 deadline (attached letter).

While Grassroots would appreciate comments from the DFG regarding the EIR and the EA, we believe it is vitally and fundamentally important to clarify, in writing, the DFG role and scope of review at the Playa Vista site. In particular, our concern is that the oilfield gas issues at Playa Vista have not been assessed by any independent state agency.

**It is vitally important for the DFG to clarify that it has played no role in the oversight for and/or evaluation of the newly discovered oilfield gas contamination problems of the Playa Vista site as they relate to the biology and ecosystems of the area and/or any other capacity.**

The California Environmental Protection Agency- Department of Toxic Substances Control (DTSC) did respond, in writing, to the LARWQCB regarding the City of Los Angeles' / Playa Capital gas study(May 2001), wherein DTSC stated the City study was incomplete and that:

-soil gas studies needed to be performed in native, undisturbed soils (studies performed thus far were done in soils that were predominantly disturbed from construction activities and had other problems noted by DTSC) and that,

- an ecological risk assessment needed to be performed (LARWQCB does not perform ecological risk assessments);
- the DTSC sister agency, the LARWQCB, has not requested or required Playa Capital to fulfill the DTSC recommendations.

*Because the oilfield gases, including benzene, toluene and xylene (BTEX) and oilfield generated hydrogen sulfide (H2S) are not issues within the scope of review for the LARWQCB, and because the LARWQCB has not adhered to the DTSC recommendations, or requested DTSC to step in for oversight of the oilfield issues (of CAL EPA agencies, DTSC has oilfield toxics within their scope of review and expertise) , there continues to be no independent state oversight for evaluations of the oilfield issues.*

#### **DFG HISTORY**

*I have requested of the DFG, through numerous DFG personnel, including those in OSPR, of any ability of the DFG to engage in a biological study of the potential negative consequences of the oilfield operation gas migration hazards that we now know exist at the Ballona Wetlands, the site of Playa Vista. Furthermore, the impacts of the construction activities creating enhanced gas migration and H2S production are also issues that potentially affect the ecosystems of Ballona. Thus far, there has been no response from the DFG that it has the ability to engage in any way regarding any of these matters.*

*In conclusion, if the DFG does not clarify the fact that it has played no role in the oilfield gas issues and apparently cannot engage these issues under its scope of review and study, then any action and/or response the DFG does engage in at the Playa Vista site will leave and, has left a biological gap of oversight that needs to be clarified. **It would be entirely misleading to the public** if the DFG were to continue involvement at the Playa Vista site and not clarify exactly what it does and does not include within its scope of review, with regard to its conclusions and/or recommendations regarding the Playa Vista site.*

***Mr. Raisbrook, Grassroots Coalition respectfully requests a written clarification of the DFGs role in oversight of the newly discovered oilfield gases that are migrating to the surface at Playa Vista.***

*I'm sending along a Public Record Act request for your help in our providing a formal request for the information requested above and also because of our need for a copy of the Habitat Mititgation and Monitoring Plan (HMMP) for Playa Vista.*

**SCOPING: It is vitally important for CDFG AND OTHER AGENCIES TO MAKE CLEAR TO THE PUBLIC WHAT OVERSIGHT THEY DO AND DON'T HAVE.**

## **ISSUE #2**

### **SUBSIDENCE AND UPLIFT**

**SCOPING----SUBSIDENCE issues have not been addressed and must be addressed .**

State law requires the avoidance of subsidence in coastal areas from oilfield fluid production..

- What are the effects and potential negative impacts due to ongoing subsidence?
- Why has this issue not been address and no monitoring has been done by the state even though it is a policy of this state in coastal areas.

#### **"SUBSIDENCE IS CAUSED BY FLUID WITHDRAWAL:**

*"Fluid withdrawal from a petroleum reservoir or aquifer leads to the inevitable result of causing land subsidence at the surface, and compaction of sands at the reservoir level. The compaction is due to a pressure decrease in the reservoir or aquifer, and causes the overlying formations and the land surface to sink. This deformation leads to fracturing of the geological formations in the surrounding areas, causes movement along existing fault structures, and damages the oil and gas well casings and seals. This gives rise to the upward migration of gas from the petroleum reservoir. The interaction between subsidence and gas migration is illustrated in Exhibit 1.*

*The geological deformation is greatest at the reservoir level and propagates to the surface as a bowl shaped configuration, as illustrated in Exhibit 2. The maximum subsidence is at the center of the bowl. For a petroleum reservoir, the extent of the subsidence bowl at the surface is approximately twice the areal extent of the reservoir.*

....

*As a general rule, the amount of subsidence experienced at the surface correlates directly with the volume of fluid production within the reservoir. ...*

#### **2. FLUID WITHDRAWAL HAS CAUSED SIGNIFICANT SUBSIDENCE AT PLAYA VISTA, PLAYA DEL REY AND THE MARINA PENINSULA AREAS:**

*Fluid production of oil and brine water from the Playa del Rey and Venice oil fields caused nearly two feet of surface subsidence between 1927 and 1970. The California*

*Division of Oil and Gas (DOG) documented this in their Sixtieth Annual Report published in 1974. ..(exhibit 3)*

*...SOCALGAS has operated an extensive oil field dewatering program with the 'Del Rey Hills Area' and the 'Venice Area' for many years. This has been necessary since the gas storage operations requires continuous pumping of brine water from these areas to prevent invasion of the water into the primary storage zone reservoir.*

*The average daily production from their dewatering wells is approximately 2,500 barrels of brine water per day. This would equate to over 90,000 barrels per year, or over 27 million barrels of fluid production between 1970 and the present. It is inevitable that this has contributed to the subsidence problem, additional geological fracturing, and additional damage to the oil and gas well casings and seals.*

### 3. CITY OF LOS ANGELES SURVEY DATA HAS CONFIRMED THE EXISTENCE OF A SERIOUS SIBSIDENCE PROBLEM:

*I utilized survey data generated by the City of Los Angeles to evaluate the extent of the subsidence problem in the Playa Vista Area (near Jefferson Blvd. and Lincoln Blvd.) in the vicinity of the Playa del Rey oil field. The data utilized is presented in Exhibit 5.*

*...In summary, these data establish that the Jefferson/Lincoln area subsided .267 feet over a 14-year interval from 1956 to 1970. The Pacific /Lighthouse area, a well known subsidence prone area, subsided .265 feet over a 15-year interval from 1955 to 1970. Accordingly, these data confirm that the subsidence problems caused by oil field production are widespread, and extend to the areas that are under development at Playa Vista. No systematic monitoring of these problems has been undertaken since 1970.*

### 4. THE SUBSIDENCE PROBLEMS IMPACT THE INTEGRITY OF THE OIL AND GAS WELLS THROUGHOUT THE AREA:

*Fracturing of the geological formation and damage to the well casings from subsidence will cause upward migration of gas to the surface, exacerbating the near surface soil gas conditions. In the referenced area, over 200 oil wells were drilled and completed prior to the onset of the significant subsidence discussed in this document. Accordingly, subsidence must be recognized as a major contributor to the gas migration problems that have been documented at Playa Vista.*

*...It is apparent that the gas migration problems at Playa Vista are strongly interrelated with the movement of leaking gas easterly within these gravel zones as a result of being 'swept' by the tidal forces and wave energy within these permeable zones.*



## 5. SURFACE DEFORMATION:

*Deformation due to compression and extension at and near the land surface causes fissures in the soil and damages buildings, pipelines, and other structures. In the subject areas, these problems are complicated by the 100% liquefaction prone region that has been identified in the Seismic Hazards Map published by the Division of Mines and Geology, and by the near surface water table.*

*Regionally water tables will remain at nearly the same elevation after local subsidence lowers the land surface. The effect is to decrease the depth to the water level. If the water table rises (relative to the land surface), higher than the bottom slab of a building, the uplift pressure on the structure will be noticeably increased. This could cause the slab to eventually rupture.*

*Likewise, the below-slab installation of a gas membrane barrier for gas control purposes could be adversely impacted by these same uplift pressure conditions.....*

*City of Long Beach....an elaborate water injection program to mitigate the consequences of surface sinking and water incursion in this coastal area. ...*

*The city of Redondo Beach failed to impose such a requirement on oil field operations conducted under the King Harbor Boat Marina. Approximately two feet of subsidence, which occurred over a period of 20 years of oil production, caused the breakwater rubble barrier, constructed by the U.S. Army Corps of Engineers, to sink. A winter storm in 1988 destroyed the rubble barrier, and the city of Redondo Beach and the U.S. Army Corps of Engineers were held liable for the millions of dollars of damage that resulted to the shoreline structures. They were found to have been negligent for failing to monitor for the subsidence and for their failure to take protective measures to minimize the risk of injury.*

*It is significant to point out that the level of subsidence measured in the Playa del Rey and Venice coastal areas through 1970 is similar to the subsidence that caused the destruction of the King Harbor at Redondo Beach.*

*( Society of Petroleum Engineers Paper 83504 Environmental Hazards Posed By The Los Angeles Basin Urban Oilfields: An Historical Perspective Of Lessons Learned- Bernard Endres PhD; George V. Chilingar PhD)*

***...A systems engineering approach is necessary in evaluating the interactive consequences of subsidence, gas migration and movement of gas through the near surface aquifers from the locations of the leaking wells. This requires a detailed evaluation of the hydrology and the tidal actions that are responsible for moving the gases easterly within the aquifers and under the Playa Vista development."pgs 1-8***

**Bernard Endres PhD to LOS ANGELES BUILDING AND SAFETY**

**REGIONAL GROUND SUBSIDENCE AT PLAYA VISTA, PLAYA DEL REY AND THE MARINA PENINSULA, AND RELATED GAS MIGRATION PROBLEMS**

( See also SOCALGAS- PDR p.768-9 ; 2012-The Environmental Aspects of Oil and Gas Production Subsidence by J.O. Robertson, G.V. Chilingar; L.F. Khilyuk, and Bernard Endres)

NOTE: The Settlement Agreement (SA) between SCG and Grassroots Coalition (GC) includes INSAR subsidence monitoring. However, SCG has not complied with the SA as it has not provided INSAR subsidence monitoring imagery of a high resolution necessary for expert review of the data. We are still requesting the imagery.

**SCOPING-- The EIS/EIR needs to include a systems engineering approach for evaluation of the subsidence issues that are ongoing in the Ballona area.**

(SOCALGAS has implemented a water injection program under Area A according to PDR –SOCALGAS officials however, no correlation or explanation has been provided by SOCGALGAS experts.)

-The EIS/R needs to provide thorough evaluations of this issue which overlaps the tidal influences and detriment to the freshwater aquifers that the ‘estuarine’ PLAN promotes.

-The EIS/R needs to provide ALL REASONABLE ALTERNATIVES of Ballona’s restoration which has not been done. The public has been cut out of the process of alternative planning. Thus, the current EIS/R process is a ruse and a process that has fundamentally abused the taxpayers funding of review through bond money intended for a legitimate restoration process providing PUBLIC INCLUSION prior to this end point that has a predetermined outcome by the state agencies engaged.

-The newly adopted City of Los Angeles Methane Ordinance imposes a condition of dewatering in order to prevent the shallow water table---existing throughout the subject area—from invading the perforated pipes and gravel layer. The perforated pipes and gravel layer are required to passively vent the upward migrating oilfield gases from invading buildings and creating an explosion hazard.

If the perforated pipes and gravel layer are invaded by groundwater the gas venting systems become dysfunctional. Thus, dewatering becomes an essential part of implementing the City of LA Methane Ordinance. However, subsidence may result upon pumping the groundwater, necessary to achieve the dewatering, especially because numerous other ongoing decontamination dewatering is ongoing at Playa Vista. **The cumulative dewatering effects have not been addressed at the site since the ordinance was adopted by the City. This imposes a higher duty upon those responsible for protecting public safety.**

## 10.0 ENVIRONMENTAL CONCERNS

### Cleanup and Land Disposal Sites

Within less than one mile of the Study Area, as shown on Figure 9, twenty-three sites with environmental concerns were identified on GeoTracker (SWRCB, 2010). Of these sites, 12 are leaking underground storage tanks sites (LUSTs), 10 are other clean-up sites, and 1 is a DTSC clean-up site. Sites identified as still active under regulatory oversight include 7 LUSTs, 7 other clean-up sites, the DTSC clean-up site, and the land disposal site. Table 2 provides a summary of the information available from GeoTracker for each site.

The active cleanup sites located up-gradient from the Study Area may pose a risk to the soil and water quality of Ballona Wetland.

### Underground Methane Storage Reservoir

The Playa del Rey storage field, a large natural gas storage reservoir that is owned and operated by the Gas Company, is located at depth beneath most of Study Areas A and B, including the southern half of Marina del Rey, most of Playa del Rey, and the terminus of Ballona Creek (see Figure 10). The limits illustrated on Figure 10 include a quarter mile radius measured around the outer limits of the storage field, where the air and ground surface may be effected by fugitive gas or odors released from the natural gas storage reservoir or where subsidence may occur due to changes in pressure from within the reservoir. This radius is termed the area of potential influence by the Gas Company. Formerly an oil field that produced during the 1930s, it was converted to a natural gas storage reservoir when the pressure in the field dropped below optimal levels for oil production. The Playa del Rey storage field is located approximately 6,100 feet below the ground surface in Tertiary-age sandstone, which is capped by approximately 1,500 feet of impermeable shale. Fifty-four active wells and three compressors are used to inject and withdraw methane gas into and from the formation.

On December 20, 2007, a settlement agreement was approved by the California Public Utilities Commission (CPUC) in response to complaint cases against the Gas Company and its operation of the Playa del Rey storage field. This settlement includes an odor program, which involves routine patrols in the area for vagrant odors from the field, natural gas venting, engine and exhaust odor minimization, reduction of fugitive emissions, and the installation and maintenance of a meteorological station. Monitoring of the soil gas, subsidence, gas pressure, withdrawn gas chemistry, and released liquids are also included in the settlement agreement.

The Playa del Rey storage field poses an uncertain risk to Ballona Wetland and the habitat alternatives, with regard to possible release of methane gas and possible ground subsidence related to the operations of the storage reservoir.

### **SCOPING:**

**-The issues of thermogenic gas hazards and subsidence concerns raised herein by GC in detail have not been evaluated and need to be.**

**The CITY OF LOS ANGELES expert- Victor Jones of Exploration Technologies v Inc. current and past data production needs to be included in the SCOPING ASSESSMENTS.**

**-Still Workin On It must be included as it refers to the actual failures of the experimental gas mitigation systems which give rise to needs of groundwater withdrawal and the effects of that groundwater withdrawal.**

**--Include Jones' response to SOCALGAS regarding gas sampling and gas migration in the freshwater marsh (catch-basin) via the currently leaking well**

**-University City Syndicate-(this well was last abandoned by Playa Capital LLC. With financing from the City of Los Angeles taxpayers.)**

[YouTube - Playa Vista Ga#18A265](#)

[YouTube - playa vista ga#18A23D](#)

**Reference below to University City Syndicate by Victor Jones- ETI**  
**As part of overall review of the URS gas studies assessment for SOCALGAS.**

(URS engagement with both Playa Vista and SOCALGAS should be considered a conflict of interest in any work performance of the restoration of Ballona.)

*"It is particularly significant to note that this response is associated with an abandoned dry hole that is not a gas storage well, and has never produced oil or gas. The ETI data discussed above was collected in 2001 before the well was re-abandoned by Playa Vista. Following re-abandonment the leakage around this well has significantly increased and today is reported by DOGGER to be vigorously bubbling around the casing and includes additional vents more than 100 feet away from the casing. Actual Youtube videos*

*http://www.youtube.com/watch?v=LR1r9X2VGZo&feature=geosearch and http://www.youtube.com/watch?v=NNA2f3GvUPg&NR=1) show these gas bubbles. An excellent report on this extensive gas leakage from the Syndicate-1 well is discussed in a 12 July 2010 letter report (Geoscience Seep Gas Analysis.pdf) submitted by Lewis Pandolfi.*

*A similar response to this could be found around any well in the general Playa del Rey area, regardless of whether it is, or was a gas storage well, or an abandoned oil and gas well. **All old well casings are potential leakage conduits and all of the known wells, whether abandoned or not, should have been included in the planned phase I soil gas survey.** This increase in leakage activity is obviously related to the re-abandonment of the well. It can never be assumed that a re-abandonment of any well will always be successful. Follow-up soil gas surveys are the only way to prove that the re-abandonment was successful. " Exploration Technologies Inc., Victor Jones 2011*

Please also respond to the following comments:

The comments raised above (part of a FOIA response from USACE- GeoPentech Report) acknowledges uncertain risks to Ballona and the 'Plan'(s) but thus far the SMBRC/ COASTAL CONSERVANCY AND CDFG and USACE have ignored GC's

concerns and refused to allow GC to provide public presentations at SMBRC meetings or at Ballona watershed meetings--regarding these concerns. Once again, failure to communicate and share with the public, lack of transparency—is the proven objective with the agencies. The Ballona land was acquired with public bond money, the land belongs to the public and the agencies are supposed to be providing stewardship that includes feasibility of alternatives WITH the public. This has not occurred. Thus far, the state is acting as though Ballona is a residential development site owned by the state and that the public must respond TO ONLY WHAT THE STATE TELLS IT TO RESPOND TO AND OTHERWISE BUTT OUT!

This is apparently the state's attitude for its 'supposed' request for the USACE to disengage from the 2005 Joint EIS/R process and stop including the regional Ballona ecological areas and biological values.

According to USACE -FOIA'D documents, the state did not fulfill its contractual agreements. This failure causes the state to also lose the financial support of the federal government that are cited as 65% of restoration costs.



**SCOPING:**

This is just one example of high volume oilfield gas leaks to the surface—shown here are gas leaks leading to the shut down of the SOCALGAS gas injection operations. (DOGGR 1008 Order)

-The Settlement Agreement and the follow up studies and the GC response to SOCALGAS and the CPUC need to be addressed and analyzed due to the extreme health and safety issues.

**SCOPING:**

- Needs to include recent DOGGR 1008 Order responsive documents and historic SOCALGAS documents (currently the state has provided only hearsay discussion from SOCALGAS). Some of those documents are included in this submission to alert regarding the oilfield gas migration hazards that SOCALGAS continues to avoid as it fails to abide by the Settlement Agreement between Grassroots Coalition and SOCALGAS.

Example document:

*InterOffice (GAS COMPANY) CORRESPONDENCE*

*Playa del Rey- Gas Migration*

*"The area where storage gas is currently surfacing is in the flat area. Sound logs suggest gas movement from a depth of about 1000' below sea level. The temperature anomaly in Del Rey 18 is approximately 1100' below sea level."*

(Del Rey 18 is located at Fisherman's Village and the 'flats' are the land areas below the bluffs- GC)

*"We have also had reports this year of gas containing helium present in the surface casing annulus of 26 wells. "*

(Helium is often used as a marker for SOCALGAS reservoir gas migration since the gases piped in from Texas, Oklahoma ...contain helium and the PDR field has no historic helium within the oilfield according to the City and DOGGR records. No native gas samples exist of the field from prior to injection of foreign gases. (CPUC discovery queries upon SOCALGAS)

**SCOPING:**

**-Please provide accountability and legal legitimacy for withdrawing from the 2005 Joint EIS/R process.**

**-Please provide all financial accountability for federal funds already spent. How was the money spent and what was the outcome of the expenditures?**

**As can be seen in the diagram below, there are numerous active and abandoned wells that must be tested for leakage regularly. Further saltwater intrusion will present not only a potential for casing leakage due to that salt water corrosion but will also pose a more difficult circumstance within which to REPAIR and STOP the leakage and furtherance of at least the GREENHOUSE GASES.**

- **Mitigation measures and monitoring of all wells must be part of the scoping of issues needing study and response. What is planned for such study and monitoring of these issues by the state and federal government?**
- **Thus far studies have not occurred. What assurance that these health and safety issues WILL be addressed and mitigation provided?**

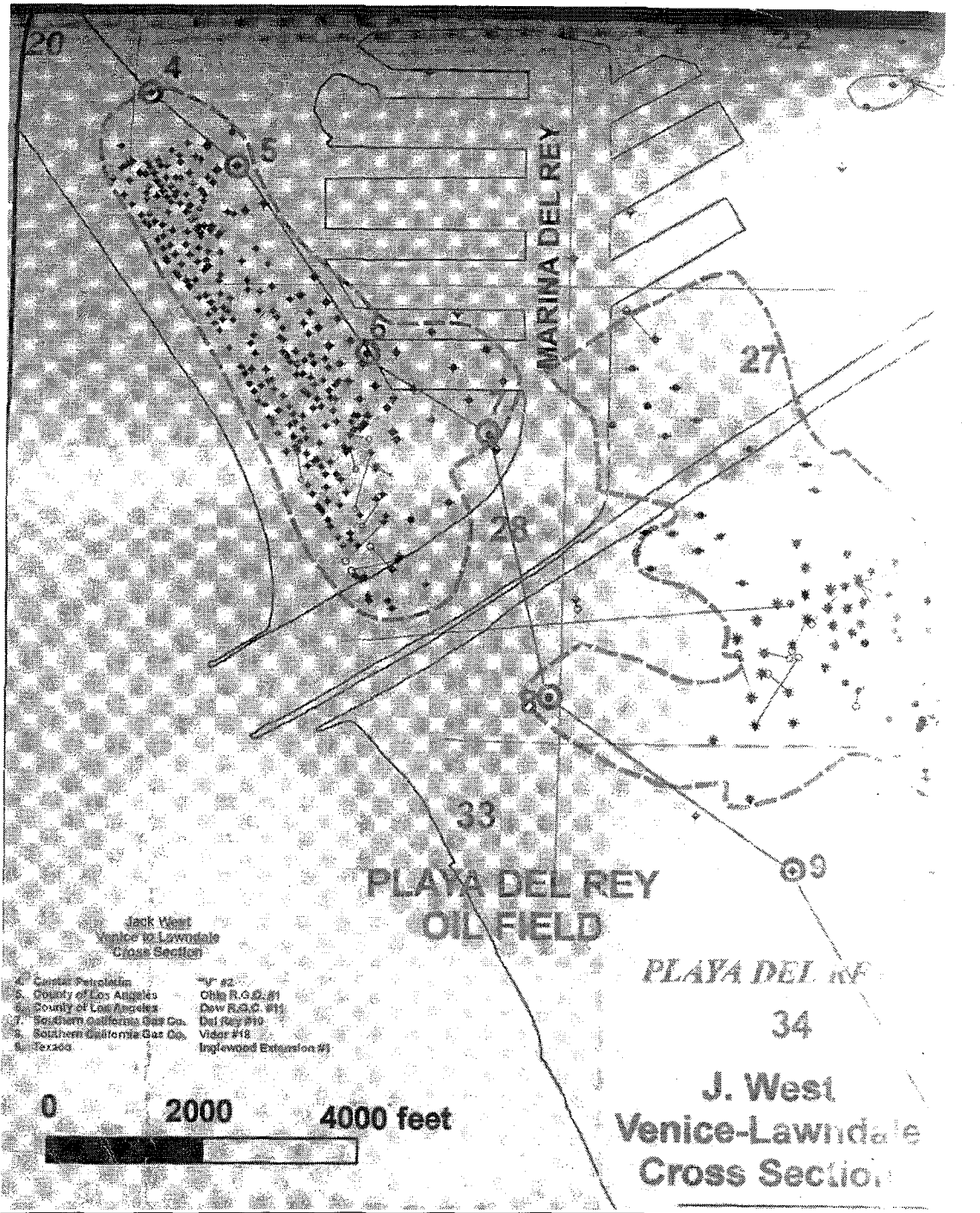

### **ISSUE # 3**

#### **HYDROLOGY & DEWATERING**

-Why have the state and federal agencies failed to provide the iterative process that was promised to the public for use of public bond money and federal taxpayer funding? Scoping needs to include the history of what has occurred and respond to

why and how the public has not been allowed to cross share information and be part of the planning process for restoration alternative planning of Ballona.

-Address why no hydrology studies of the near surface aquifers and streams have been done during the so-called 'feasibility' phase.

-During the 'feasibility' phase GC and others of the public requested an ACES program study be performed upon Ballona in order to fully understand the hydrology of the area which includes the underlying groundwaters and its surface waters.

-The ACES study needs to be performed.

[PDF]

### **ACES: Analytical Framework for Coastal and Estuarine Study**

[proceedings.esri.com/library/userconf/proc08/papers/.../pap\\_2183.pd...](http://proceedings.esri.com/library/userconf/proc08/papers/.../pap_2183.pd...)

-Why has there been no response from SMBRC/ Coastal Conservancy on this issue of concern and why was this request not provided to USACE AND CDFG?

-Provide hydrology studies that reveal the current levels, locations and sources of groundwater in Ballona.

-How have the groundwater levels changed over the past 20, 50, 100 years? What has caused those changes? And, how can the freshwater resources be restored and utilized for Ballona?

-What studies provide review of protection of the groundwater sources in Ballona?

- Why has the ACES, sanctioned by the USACE, program for estuary mapping not been employed as requested by the public at Ballona?

-What freshwater resources are available for restoration purposes at Ballona and how can they be utilized?

-How much groundwater of Ballona is being diverted and/or otherwise not being allowed to recharge the area?

-What are the cumulative volumes of groundwater that Playa Vista is diverting from the wetlands and why is this allowed to occur?

-What studies have been done to assure the fresh groundwaters are not negatively impacted by the proposed 'Plan' and how can the "Plan" be implemented when diversion of contaminated and toxic Ballona Channel waters and sediments ( as cited in the Weston Report on Coastal Conservancy CD) and further contaminated saltwater intrusion provides for one impaired water way into another. Is this not a violation of the Clean Water Act and Porter-Cologne?



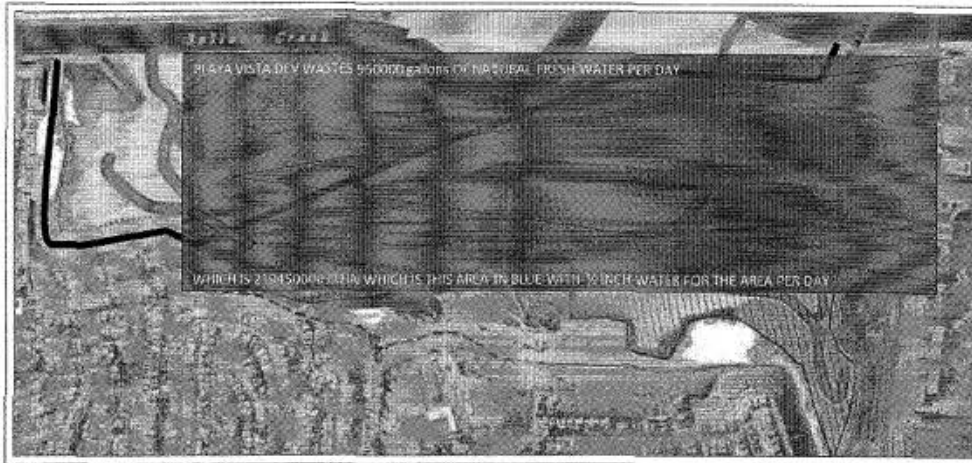

This GC visual aid shows an approximate amount of water permitted by the Dept. of Sanitation- daily to Playa Vista for 'wastewater' dewatering. The removal and throwing away into the sanitary sewer system of this precious groundwater that is classified as 'potential drinking water' should not be allowed. This same volume would/could create a half acre pond at 1 foot deep---in one day.

#### SCOPING:

- Provide analysis of the actual volumes of groundwater being diverted from Ballona by Playa Vista and provide an analysis of how this water can be utilized onsite for restoration purposes. Especially, in light of the fact that Ballona is historically dominated by freshwater flows.

- WHY is this water not being utilized onsite and for restoration purposes?

Is it not illegal for Playa Capital LLC to divert this volume of groundwater and throw it into Hyperion sewer treatment plant?

- CDFG's response regarding potential harm has thus far been---they do not know. That answer is unacceptable. Find out.

Documents from LARWQCB showing permitted discharges of 950,000 gallons per day (gpd)(16 CT 3696-3700) and LA City Department of Sanitation, including a table showing permitted discharges of up to 72,000 gpd.

- Why is this water being allowed to be diverted and thrown away and not utilized for groundwater recharge and/or a source of freshwater for Ballona restoration purposes?

- Diagrams included herein, reveal that utilizing the LARWQCB permitted discharge rate of 950,000 gallons per day; this volume of water would provide approximately 1/2 inch of water across the surface of most of Ballona Wetlands -south of the Ballona Channel. The same volume could provide in one day—a foot of water to a ponded area approximately 1/2 acre in size. The large volumes described would provide a source of freshwater to Ballona's restoration that would be incredibly valuable.

- Why have these sources of groundwater not been evaluated?

-How is it possible that Playa Vista can divert much needed groundwater away from Ballona? Especially in light of the 1993 EIR for Playa Vista requires for any groundwater discharge:

-a preapproved beneficial plan for any such extraction and discharge (EIR Vol. 26 p. 014945)

-tertiary treated groundwater from NPDES provides primary supply of freshwater for the wetland system (EIR Vol. IX- Executive Summary 1-2.

-“ongoing remediation of the known existing groundwater contamination in Area D and utilization of the resulting treated water for the beneficial use of supporting onsite vegetation, would result in a beneficial impact on ground water.” P. 12- Exhibit B- Certification of EIR and Adoption of Mitigation and Monitoring and Reporting Program.

And,

“Culverts under Lincoln Boulevard should be of sufficient size to permit wildlife movement between Areas B and D without risk of injury or death from traffic hazards.” P. 18. Mitigation and Monitoring Report

The EIR of Playa Vista also requires the

-avoidance of any long term dewatering due to negative environmental consequences

however, no cumulative analysis of groundwater extraction has been done, impacts of that groundwater dewatering have not been done and, no enforcement of metering requirements has occurred.

-SCOPING:

-The Ballona region requires hydrologic review .

NOP of CDFG cites on page 1:

Project Summary and Proposed Action

The project entails restoring, enhancing, and creating native coastal wetland and upland habitats in the

approximately 600-acre Ecological Reserve. The reserve comprises previously filled and dredged coastal

wetland and upland habitat that would be restored by increasing tidal flow throughout the project area,

removing invasive species, and planting native vegetation. Figure 3 shows a conceptual design of the

proposed restoration. The main components of the project are:

1 Habitat restoration of estuarine wetland and upland habitats connected to a realigned Ballona Creek.

1 Removal of existing Ballona Creek levees and realignment of Ballona Creek to restore a more meandering channel.

1 Construction of new levees to replace the existing Ballona Creek levees and to allow restoration of

tidally influenced wetlands while providing flood protection for Culver Boulevard and surrounding areas.

1 Installation of water control structures, including culverts with self-regulating tide gates or

similar structures, to provide a full range of tides up to an elevation acceptable for flood management and storm drainage, while protecting against some storm events.  
Maintenance of existing levels of flood protection for areas surrounding the Ballona Wetlands site and inclusion of flood hazard management measures into the restored wetlands.

---

This is description is of a preordained outcome.

The premise of restoring estuarine flow is false advertising. The CDFG already has the T-sheets –the historical studies of Ballona including that done by Travis Longcore PhD. The T-sheets and the Longcore and other scientific studies remove any doubt that Ballona was historically a wetland that utilized freshwater and was not primarily the estuarine environment that is being touted as the PROJECT.

**Please review the T. Longcore lecture, entitled "Closure Dynamics of Southern California Estuaries and Implications for Restoration" simply google as it can be found on u-Tube.**

-WHY does the CDFG mislead the public and not provide full disclosure?

- Provide the data to show what CDFG utilizes in order to claim restoration of historical functions of Ballona will occur. If not, why not?
- Provide the data to show ‘restoration’ a restoring of historic tidal influences will be occurring if the ‘Plan /Project” is allowed to occur.
- Provide the ratio of current deep and mid-tidal – with tidal flux that already exists at Ballona- including the Marina del Rey, Del Rey lagoon, Ballona Lagoon, and the Ballona Channel itself as compared with the past 100 -200 years.

**SCOPING:**

-Realignment of Ballona’s “meandering channel” is also false advertising by CDFG since the Ballona Channel never had to historically carry the high volumes of storm and runoff water that it currently carries. There is no ‘restoration’ of the historic Ballona Creek, only the forced entry of toxic LA City waters and sediment into what is now habitat for endangered species and rare native plants.

Why does the CDFG fail to provide a historically accurate account of what is proposing upon Ballona?

**SCOPING:**

-Why has CDFG not provided for Public participation and information sharing in the planning of alternatives for Ballona and instead is promoting a non-historical conversion project that creates a catch-basin end of pipe solution and flood control devices- NOT HABITAT-upland or otherwise—that protects ONLY PLAYA VISTA?

- Since the USACE has stated that it will no longer pursue the 2005 restoration process via the Joint EIS/EIR- and since the USACE is not requesting Ballona Channel changes, please discuss why the CDFG provides a false allusion of need for flood control for Culver Blvd. and what ‘other areas’? Or, if CDFG believes there is a

current need to change the Channel for protection to the public from flooding--- please list those needs and provide the data support.

**SCOPING:**

-PLEASE PROVIDE studies that determine ANY PROTECTION TO CULVER BLVD. OR OTHER AREAS ARE NECESSARY if the Ballona Channel is left in its current location.

CDFG provides false and misleading information in the NOP via omission of historical facts.

**SCOPING:**

**\_ Please discuss and provide** any and all data that provides validation of CDFG's claims that the enormous -approximately 20' above road level with sides that must be ENGINEERED TO REMAIN VERTICAL 'upland habitat' is enhancing or restoring Ballona. Provide discussion and data support to show what can survive in the giant berms that are shown on the Psomas contour maps in Area C and south of the Ballona Channel and west of Lincoln Blvd. (Psomas-2012 contour maps)

-GC wishes to see multiple restoration alternatives that do not involve changing the Ballona Channel and that do not involve the massive bulldozing and dredging that is the singular 'Plan' or 'Project' cited in the CDFG NOP and is finalized by Psomas on its 2012 contour map.

- GC wishes to be engaged and provided with multiple alternatives that would embrace freshwater sources for protection and utilization for streams/ponds etc. This alternative has not been explored and needs to be explored, analyzed and presented for public review. Such alternatives would require less money to create and would/ could be self sustaining . Such alternatives would be respectful of the Native American heritage of the site and provide for habitat closely aligned with historic Ballona and its inhabitants—both human and wildlife and flora.

- Why has CDFG not allowed for public participation and sharing of data and information for the public to be engaged in alternative planning??

**ISSUE # 4 PROCESS**

**Background and overarching scoping needs-**

The promised hydrology studies (2005 Joint EIR/EIS—between USACE & the Authority ) of Ballona Wetlands have not been done. Instead, the SMBRC/FOUNDATION -director & staff and the California Coastal Conservancy have interfered with and stopped the areawide ecological studies and geotechnical studies of the federal review for restoration potentials in the greater Ballona region in order to promote a singular 'Plan' of destruction and experimental construction upon Ballona Wetlands- Areas A,B,C . This "Plan" excluded groundwater hydrology studies and focused upon hydrolics studies of surface water flows into Ballona Channel .

We believe that this 'Plan' is nothing more than a destruction of endangered species and wildlife habitat that is currently functioning well and that the Coastal Conservancy contracted- Psomas Co. contour maps of the "Plan" reveal that it is a flood control plan that only benefits a private development known as Playa Vista (Playa Capital LLC). The Proposition 12 bond funds have illegitimately been spent on private use protections to a development site that was illegally allowed to build in a flood plain. FEMA was not engaged for oversight comments as needed as the EIR process for Playa Vista was thwarted by failure to utilize the Clearinghouse as a gateway for proper notice to all pertinent agencies. ( ETINA v City of LA; Playa Capital LLC) This failure by the lead agency- the City of Los Angeles- to include and enforce California Environmental Quality Act (CEQA) protocol of Clearinghouse utilization **PLACES THAT BURDEN NOW UPON USACE AND THE California Dept. of Fish and Game and its state agency partners. FEMA MUST NOW BE ENGAGED** and the issues that pertain to flood protection for Playa Vista must now be reviewed in light of the flood control devices and the preordained 'Plan' of development and construction proposed by SMBRC/Foundation and the California Coastal Conservancy.

The giant berms and levees-approximately 20 feet above current road level as shown in the contour plans – are NOT habitat; are NOT RESTORATION but instead are civil works flood protection devices to benefit Playa Vista.

Furthermore, the 'Plan's' intent to DREDGE Ballona is NOT RESTORATION but instead is simply an experimental attempt at an end of pipe solution to the toxic water and sediment flow down the Ballona Channel. The catch-basin shown in the 'Plan' does NOT enhance or restore Ballona but instead destroys the very habitat that the public has spent over 20 years to protect. The effects of the 'Plan' as a catch-basin and flood control project have not been studied. Current roadways, Marina del Rey and other beach front areas appear to be put in jeopardy from the project.

**SCOPING:**

Issues of safety, failure to utilize the bond funds as approved by the public; failure to work with and include the public's participation in restoration concepts and planning; the legitimacy of process -- promised and paid for by bond dollars v the exclusionary and preordained outcome plan by the SMBRC/Foundation and the Coastal Conservancy must be addressed in the SCOPING AND DRAFT EIS/R.

Response to conflict of interest allegations, illegal use of bond funds, lack of transparency issues raised and failure to perform in good faith toward restoration, acquisition of more of Ballona, and enhancement issues that would protect and utilize the freshwater resources of Ballona onsite must be addressed and raised for public awareness of these and other challenges leveled at the lead agencies and their 'partner' agencies.

A gross compartmentalism has taken place by the steward agencies in order to create a predetermined outcome – the 'Plan" that excluded the public and its participation.

The current Notice of Preparation by the CDFG provides appearance of –just starting- the process for restoration at Ballona. This is false and CDFG fails again to act in good faith and provide accurate history. Instead, the CDFG while stating verbally at the ‘scoping meeting’ (which was not a scoping meeting conducive to public awareness and cross sharing of information) that all alternatives are being considered—instead the NOP shows the story of preordained outcome of ‘estuarine’ environment ONLY AND CHANNEL CHANGES AND DREDGING ONLY.

- **SCOPING NEEDS** to address the NOP and its showing of a preemption of the iterative process as promised and bond funds provided for.
- **SCOPING NEEDS** to address and respond to why CDFG and its partner agencies have NOT abided by public participation in the planning of restoration concepts and are –instead promoting the SINGULAR PLAN of the construction of a flood control basin and flood protection device(es) to protect Playa Vista.

#### **SCOPING NEEDS TO INCLUDE :**

-Response to comments and questions within the Jan. 2012—Bond approval for \$6,490,00. by John Davis to California Coastal Conservancy must be addressed.

- The John Davis to Ca. Coastal Conservancy document of March 28, 2012 entitled- Request to Hold Emergency Meeting to Rescind Approval Action on File No. 04-088 must be addressed and provided response since the issues pertain directly to the restoration of Ballona and the Coastal Conservancy’s; USACE’s, SMBRC’s/FOUNDATION; CDFG ‘s in partnership---lack of adherence to stipulated use of public bond money for the publically owned Ballona Wetlands.
- Include response to the Amended Complaint to the Ca. Coastal Commission by Grassroots Coalition, dated August 2, 2012. The three documents ,490,00.are attached to this response.
- The partner agency – Ca . Coastal Conservancy has thus far provided no response whatsoever to these Complaints that have attached data support.
- The Amended Complaint by GC has an attached CD that contains Public Record Act documents from the Coastal Conservancy that provide the data support to the Amended Complaint. The contents of the CD should be part of this record and provided in full to the public for informed decision making. No agency is the ‘owner’ of Ballona Wetlands but instead the agencies play a role in stewardship of land OWNED BY THE PUBLIC. The public process has been hijacked by these stewards apparently to fulfill private corporate interests. This is not acceptable behavior by our state and federal agencies. Therefore, any attempt to obfuscate the history of Ballona and its ‘restoration’ path – a path that was to fully include the public to provide alternative planning via informed decision sharing and making—is considered further proof of hostile hijacking of due process.

#### **SCOPING:**

Needs to include the history of the “restoration” process of Ballona, including but not limited to the 1995 and 2005 Notice of Intent and the contractual agreements between the USACE and the Authority- SMBRC/County Flood Control. The history must include CDFG’s participation in that process and acknowledge for accountability purposes- why that process is not being adhered to at present.

-Acknowledgement of the congressional issues of House Document 389 and any and all Feasibility Reports need to be accounted for as to intent and outcome.

Wildlife Issues:

Credit for Graphic:

Anderson, Sean. 2012. Splatter Spotter: Exploring and Predicting Elevated Vertebrate Road Kill Across the Santa Monic Mountains and Beyond. Chautauqua Lecture. Temescal Canyon Park, Pacific Palisades. August 22.

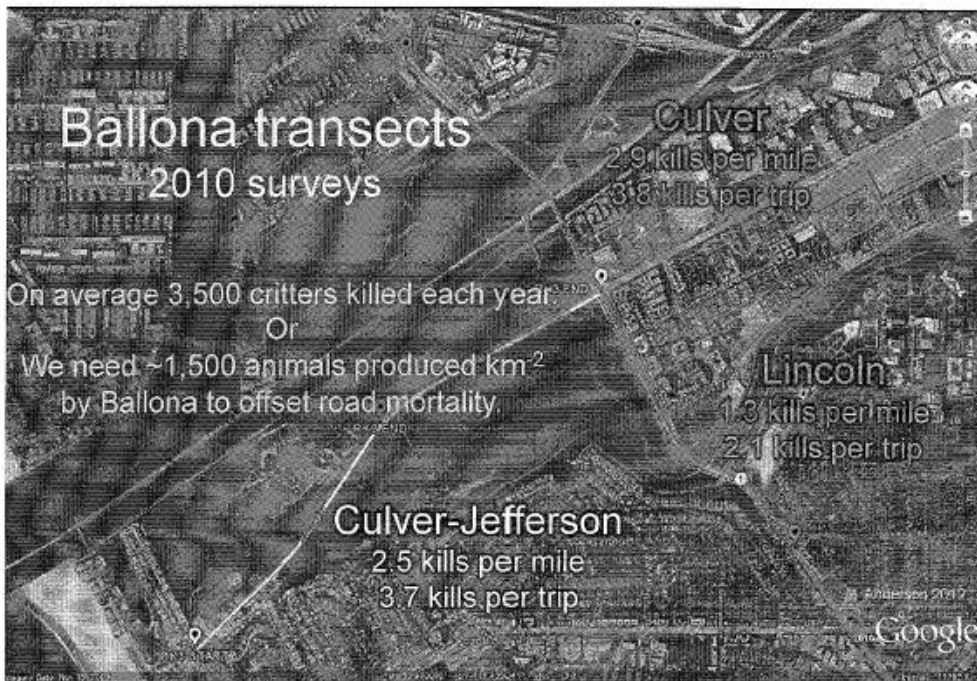

The EIR process with Playa Vista –mitigation provided for culverts for wildlife movement to prevent roadkill. Playa Vista has not honored this EIR requirement of mitigation and CDFG and the City of Los Angeles refuse to enforce it. Thus, how can the public expect CDFG to promote and protect the wildlife interests in the 2012 EIS/EIR? History reveals itself with our state and federal agencies failing to protect the environment and its wildlife. Corporate interests and money appear to be the driving force behind the state’s “Plan” of Ballona destruction and construction into a

flood control project to protect Playa Vista and as an experimental end of pipe solution to the toxic waters and sediments of Ballona Channel. Please address these allegations.

Endangered Species habitat and nesting areas will be destroyed. The Belding Savannah Sparrow –as one example- is a non migratory bird that utilizes both side of the Ballona Channel for nesting and foraging. The intended massive bulldozing /dyking and filling of Ballona will destroy its habitat. See the Coastal Conservancy – Public Record Act requested CD for documents pertaining to wildlife issues.

Vague comments by state agency personnel vaguely recite in emails and minutes of private meetings—that the Beldings will just have to move. This attitude is excruciatingly unscientific and it is painful to read such callous rubbish but it does reveal the throw away mentality that the state agents have. Thus far, the taxpayers have not been included in any alterative planning as required and thus far their money has been spent –apparently in its entirety of Prop. 12- for hydraulics studies for their singular end goal of creation of a catch-basin and flood control construction for Playa Vista.

Page 13- Additional Complaint –GC to Coastal Conservancy—August 2 2012  
The next paragraph, written by the note-taker- cited by CC as being CC or SMBRC staff- states the goal-

**“Estuarine biodiversity is the primary objective of the analysis.”**

(CD- June 23, 2008 SAC Conference Call Memo)

*“The project goal is to create functional estuarine habitat...”;*

***“1. Maximize area of estuarine habitat.”;***

*Opportunities to create regionally significant habitat including vernal pools and...should be pursued but **not at the expense of restoration of estuarine habitat.**”p. 14 Additional GC Complaint to Coastal Conservancy*

The public/Working Group was not allowed to participate in the decision making and was not advised as to the differing opinions rendered by the SAC team.

Pages 16-17 of the Additional Complaint of GC to the Coastal Conservancy:  
(the Coastal Conservancy continues to be nonresponsive)

**“Rare ecosystems of the coastal marsh area are discussed internally by the SAC team with the CC project manager and staff of the Foundation; the information is not broadcasted for public awareness, inclusion of discussion and decision making as promised.**

*“Rich noted that the discussion of grasslands should include mention of the historical native grassland prairie ecosystems that previously existed in the area. The rarity of native grasslands should be discussed,,,” (CD- 6/28/08 SAC Conference Call)*



*"Rarity section...complex of prairie and vernal pool...  
Wet grasslands formed extensive areas were also palustrine wetlands above highest  
high tide.." (CD- SAC Call 6/23/08)*

*"...there is native biodiversity in the non-tidal saline soils. .... At Ballona, these wetlands  
at Area A, for example, are the only habitat where Alkali Barley (*Hordeum depressum*)  
is known to occur in the Ballona Ecosystem. This annual grass was probably the  
dominant native annual grass in naturally occurring non-tidal saline soils at Ballona."  
(CD- 11/23/08, Wayne Ferren communication to Mary Small...)*

And,

*"The region has a shortage of mudflat for shorebirds, high marsh for animals and salt  
marsh bird's beak, marsh-upland transition for rare shrubs (eg. , box thorn) that are  
used by animals,...*

*The region has a shortage of dune habitat and back – dune depressions that support  
clean-water brackish marsh for aquatic plants and animals.*

*One could also list maritime scrub, which remains in several places "...  
( CD- Joy Zedler (SAC) correspondence)*

Thus , without public /Working Group inclusion and input into the formation of the  
alternatives and later failure to include the public /Working Group comments and  
concerns regarding the PWA Alternatives that are presented at one public meeting--  
the CC and Foundation staff continue to work behind publically closed doors to  
focus upon the 'Preferred Alternative", now known as Alternative 5 presented in the  
1/19/12, Staff Recommendation request for funding. Alternative 5 requires  
massive, non-historic, extraordinary, experimental and knowingly toxic changes to  
occur on the land masses of Area A and B so that **"biodiversity = highest richness  
of estuarine dependent species."**

**And also from the Additional Complaint—GC to Coastal Conservancy-p 17-18:**

**Contrary to the 8/13/04 CC Memo which promised transparency and public  
inclusion in the alternative planning process** which would "restore and enhance"  
a mix of wetland habitats....and that would implement a technically feasible, cost  
effective, ecologically beneficial and sustainable restoration.

Instead, the public was shut out of the planning process; and SAC knowledge  
regarding the **needs and dangers posed by Alternative 5 are not made public:**

*"This alternative makes the greatest change to the site, would be the hardest to  
reverse and consequently has the most risk." (CD- 9/12/08 MEMO from SAC to PMT )*

*" ..this alternative would **require reliance on upstream flood control and pollutant  
removal**, and could necessitate periodic removal of accumulated pollutants for some  
portions of the restored wetlands. Furthermore, it is unknown how the flow and*

*sediment yield from the upper watershed would affect the sustainability of the marsh in terms of scour or sediment deposition.” CD, P. 4 of 9, 10/15/08 SAC MEMO, emphasis added.*

There is no evidence of any such large scale BMP (Best Management Practice) planning or proposals for “flood control and pollutant removal” occurring upstream on Ballona Creek.

And,

*“Eric suggested that there be a statement up front indicating that this site will not be self-sustainable, but will need to be actively managed in perpetuity.” ( CD- 7/7/08 SAC Conference Call)*

Discussion and comments made from key federal agencies were withheld from the public, including but not limited to **NOAA communications regarding concern of toxicity of Ballona Creek upon the remaining wetlands should the levy removal and dredging take place.** (CD- National Oceanic Atmospheric Association email)

Studies that discuss the toxicity of the Ballona Creek waters and sediment to life in the waters and sediment were not released or shared with the public:

*“These sediments were toxic to aquatic organisms, potentially from organic compounds in these sediments. Ballona Creek has been identified as a potential source of tidal flows into Areas A, B, and C in each of the proposed restoration alternatives. Therefore, there is concern to tidal marsh areas, resulting in a negative impact to the habitats and biological resources.” (CD- Weston –Technical Memorandum 11/26/07; Water Quality Data Gap Investigation Ballona Wetlands Restoration Project- Pohl , P.E., Ph.D.)*

And,

*“ The July 2006 report by Weston also concludes that there are concerns related to water and sediment quality adjacent to the tidal channels. Consequently there is a need to develop a strategy to evaluation the potential ecological risk associated with influent water or sediment quality to the restored wetlands.*

*The scientific questions regarding sediment and water quality cannot be answered based on the information currently available, and will ultimately depend on the design of the project.” (CD- Memorandum 3/8/08; Subject:*

APPROACH FOR ADDRESSING SEDIMENT AND WATER QUALITY ISSUES)

And;

*“Eric- Conc(ept) D—is it attempt to move water and sediment into system*

*Wayne- breaching levee bringing trash, water pollution and sediment into entire area is problematic.*

*John Dixon-important to describe these NOT as projects, but a directions.*

*Ambrose- maybe D is too extreme—this won't happen anyway.*

*Dixon- do feasible maximum tidal, not D—need to scale back*

*Jeremy- may need to do that, take out realignment Ballona—include realign on Hydrologic options”*

*(CD-10/30/06 SAC Conference Call)*

**Thus, any discussion of any alternative habitat planning for Ballona is suppressed and deep-sixed from any public awareness as the state agents-promote unbeknownst to the public—a singular outcome of the estuarine-“Plan” requiring massive bulldozing and Ballona Channel changes and engineered flood control berms and levees.**

**GC has concerns regarding members of the private non-profit- the SMBR Foundation -who are also in key decision making positions to promote the ‘Plan” that are directors of SMBRC and project planners of the Coastal Conservancy . The SMBRFoundation has past and present strong ties to corporate interests including Playa Capital LLC.**

## **ISSUE- REMEDIATION SCOPING-**

-What and how will the remediation needs of SOCALGAS be analyzed?

ABANDONMENT/DEMOLITION STUDY- Playa del Rey Storage Field- Nov. 22 1993  
cites:

“Phase III-Tank Farm Abandonment and Final Clean-Up

...Environmental remediation may require significant disposal of contaminated soil and the importation of clean fill. There is also a potential for the discovery of ground water contamination. This environmentally sensitive area will no doubt provide significant challenges related to keeping our costs within forecasts. There is a potential for very high clean-up costs beyond current estimates because the Ballona Wetlands are immediately adjacent to our facilities.”

-What studies are planned and how will the potential mitigation be remediated?

-Groundwater studies need to be included in a restoration of Ballona that pertain to SOCALGAS operations. The high potential of groundwater contamination is acknowledged above in the Jacobson Engineering Report prepared for SOCALGAS.

Please include all the attached documents for review and assessment for the public.  
Patricia McPherson, Grassroots Coalition- President

**Comments on the Soil Gas Investigations Conducted by SoCalGas  
Made In Response to the Grassroots Coalition Settlement Agreement**

Southern California Gas conducted a soil gas survey in response to a Settlement Agreement that was reached between SoCalGas and the Grassroots Coalition (GC). The Settlement Agreement can be viewed at <http://www.laschools.org/project-status/attach/56.40077/APPENDIXX.pdf>. SoCalGas response thus far has been to conduct a phase I soil gas survey between June 10 to 26, 2009, with results, posted on the SoCalGas web site at <http://www.socalgas.com/safety/playa-del-rey.shtml>. The report <http://www.socalgas.com/documents/safety/PDRSoilVaporMonitoringReport.pdf> is available and can be viewed on the SoCalGas web site.

In spite of the fact that ETI's soil gas methodologies were specifically requested within Appendix A of the Settlement Agreement, they were not followed by URS during the Phase I investigation. Instead of using the ETI methodology, URS followed the California *"Advisory for Active Soil Gas Investigations, DTSC and RWQCB, dated January 28, 2003"*. Although this is the official California methodology, it is not the same as the ETI methodology, and does not obtain the same quality data. The only thing these two methods have in common is they sampled at a depth of 4' feet below surface and URS used similar sample containers having a volume of 125 ml. A review of the data obtained by URS in this phase I soil gas survey easily demonstrates the deficiencies of the California methodology for measuring the concentrations of light methane through butane hydrocarbons in the natural environment. It is very important to note that the California method is not equivalent to the ETI methodology, which was designed specifically for measuring the concentrations of natural hydrocarbon seepages from subsurface petroleum based sources.

As a stated objective, the Settlement Agreement requires SoCalGas to conduct soil gas monitoring surveys designed to find and evaluate any possible leakage of SoCaGas's "storage" and/or "pipeline gas" that might have migrated outside of the boundaries of their approved Playa del Rey (PDR) storage field and to evaluate all of their storage wells for casing leakage of either storage gas and/or and natural gas from any subsurface formation that might be migrating to the surface along any of their well casings, whether active or abandoned.

It is very important to note that this includes the Pico Formation, which is a source of numerous natural gas blowouts. This documentation goes back as far as 1944, when Riegle made a structure map of the shallow Pico Formation and suggested that it might provide a significant source of natural gas. Riegle's structure map was based on numerous Township wells that blew out and six of the main Playa del Rey gas storage wells (Union Del Rey 10, 13, 14, 15, 18 and 19) that had electric logs that could be used for evaluation of the Pico Formation. Although Riegle didn't include the Syndicate 1 on his map, it also blew out when drilled in 1930 and flowed over 5 MMcfd, indicating that the Pico source extends eastward under the Playa Vista development properties. ETI's

investigations at Playa Vista in 1999 - 2000 proved that the Pico Formation was also the source of the gas seepage occurring at Playa Vista.

Appendix A of the Settlement Agreement specifically states that the planned soil vapor surveys should use ETI's soil gas methodologies and references a Camp Dresser & McKee (CDM) report dated November 9, 2000 entitled "Report of Sampling and Analysis of Soil Gas for Methane in Tracts 49104-01-, -03, -05, -06 Playa Vista Area D for the methodology. ETI's methodology "Field and Laboratory Procedures for Soil Vapor Sampling", dated January 5, 2000 was provided by ETI in several reports issued to CDM and to the Los Angeles Department of Building and Safety (LADBS) during the 1999 to 2001 time period when Dr. Victor T. Jones, III from ETI served as the "Methane Peer Reviewer for LADBS. A copy of this document is also available directly from ETI. A review and comparison of the soil gas data obtained by URS with the soil gas data obtained by ETI during the Playa Vista investigations provides a simple way to demonstrate the deficiencies of the California methodology for meeting the objectives stated above. However, before making that comparison, it is important to point out an equally significant error in the SoCalGas/URS work plan.

There is a very important conceptual contradiction between the SoCalGas/URS work plan and the requirements contained within Appendix A of the Settlement Agreement, which states that: "*Under the first phase of the investigation, one hundred and fifty (150) soil probes will be advanced to depths of 4.0' (bg) on a 100' x 100' foot grid over all SoCalGas surface fee or leasehold interest lands*". **It is not possible to use only 150 soil probe samples to conduct a survey on a 100' x 100' grid over all SoCalGas surface fee or leasehold interest lands.** A 100' X 100' gridded survey would require several thousand samples. Obviously SoCalGas has limited the agreement to 150 samples without any regard for the requirement to collect samples on a 100' x 100' grid. With this restriction, using only 150 samples, it is impossible to accomplish the stated objectives, even if the ETI sampling and analysis methodologies had been followed.

A review of soil gas data from ETI's Playa Vista reports demonstrates that collecting soil gas samples on a grid is of a nearly equal significance to employing the correct sampling methodology and in having adequate analytical detection capability. A copy of ETI's CD\_6.2Playa Vista report released to Mr. Paul Mount, Chief of the Mineral Resources Division of the California Division of Oil and Gas by Mr. Ray Chan, Chief of the Engineering Bureau at LADBS was released to public record and is available on request. This CD contains numerous reports, data tables, maps and figures that are significant to understanding the deficiencies of the URS phase I soil gas monitoring report and the logic contained within Appendix A of the Settlement Agreement.

It is important to understand that gases migrating through the earth do not follow isotropic nor homogeneous pathways, so that making valid soil gas measurements and maps of soil gas anomalies requires the use of gridded surveys containing many samples and very low analytical (ppbv level) detection capability. Below the vadose zone the methodology must include the measurement of both free and dissolved gases in the underlying aquifers. The planned Phase II surveys cannot be completed within

this area using multi-depth soil vapor stations because the groundwater is too shallow for collection of vapor samples. Phase II must use the groundwater and/or deeper aquifers to collect and measure the free and dissolved gases in the aquifers. The lateral transmissibility of the underlying aquifers significantly aids the movement of dissolved gases, helping in relating the deeper dissolved gases to the shallow soil gases. Comparison of shallow soil vapors with deeper dissolved gases in the underlying aquifers is completely compatible so long as both are correctly collected and analyzed.

The problem with using the California methodology for measuring natural hydrocarbon seepage is not new. A demonstration of ETI's methodology was required back in 1999 when ETI was first hired to evaluate the potential methane problem at Playa Vista. An example from two soil gas surveys conducted by Camp, Dresser & McKee (CDM) over Tract 03 at Playa Vista on 9/21/1999 and 10/07/1999 using the California Geo-Probe methodology are included for comparison with ETI data that was collected in October – November of 1999, after the first two surveys were completed. As shown by this [California-versus-ETI-Methodology.pdf](#) poster, the largest methane found by the California method was 970 ppmv at site 07. The second survey conducted 14 days later reported only 55 ppmv when site 07 was resampled. CDM suggested that their data showed there were no appreciable concentrations of methane gas present in the shallow soil gas in this area, and that they had reduced the methane concentration within the soil vapor even further by purging their sampling tools in following the California sampling procedures.

In contrast, the ETI survey conducted after the two California method attempts found methane concentrations that ranged upwards of 59 to 73% (590,400 to 732,000 ppmv). These ETI sites also contained approximately 3000 ppmv of ethane, 30 ppmv of propane, less than 10 ppmv of iso-butane and less than 1 ppmmv of normal-butane. Although these C2+ gases are not large, they are indicative of non-biogenic sources. A comparison with the CDM gases, as shown below, is striking. Site 07 has no ethane or propane, but does have small concentrations of butane, pentane and C6+ (0.049, 0.773, 0.7 ppmv) and even 4 ppmv of C6+ hexanes.

|            | Monitor well MW-05<br>ppmv | ETI soil gas<br>ppmv | California Method soil gas<br>ppmv |
|------------|----------------------------|----------------------|------------------------------------|
| Methane    | 804,600.00                 | 732,000.00           | 970                                |
| Ethane     | 3,028.00                   | 2,973.00             | ND(<0.50)                          |
| Propane    | 58.10                      | 33.30                | ND(<0.50)                          |
| Iso-butane | 4.56                       | 8.33                 |                                    |
| n-butane   | 0.92                       | 0.40                 | TR(0.49)                           |
| pentanes   | 0.00                       | 0.00                 | TR(0.773)                          |
| C6         | 0.00                       | 0.00                 | TR(0.7)                            |
| C6+        | 0.00                       | 0.00                 | 4                                  |

Monitor well MW-5A (see the Tract 03 report discussed below), which is fairly close to site 07 contains 80.46% methane with 3028 ppmv ethane, 58.1 ppmv propane, 4.56 ppmv iso-butane, 0.92 normal-butane and no C6+ components. Clearly the California method soil gas data is very different from the underlying gases in the aquifer, having very small methane, a complete lack of ethane and propane and measureable butanes and other C6 hydrocarbon gases. This signature suggests the methane is diluted with atmospheric air, and the heavier components are likely contamination from the Geoprobe drill rig tools. The butanes and heavier components could not have come from the aquifer source, so contamination from the drilling tools, coupled with dilution of the soil gas is the only logical explanation.

The objective for conducting these soil gas surveys was to delineate the distribution of the gases contained with the fifty foot deep gravel aquifer that is the underlying source for the soil gas anomalies. Documentation for meeting these objectives is contained in an early report given to Mr. David Hsu, Chief of the Grading Section at LADBS on November 29, 1999. This report, entitled Tract 03 Report confirms that the ETI soil gas method compositionally matches the aquifer gases, whereas the California method does not. Plate 1 and Plate 2 from the Tract 03 report provides maps of the deeper aquifer and surface soil gases, showing the coherence between these two independent data sets. The Tract 03 report demonstrates ETI's methodology for mapping migrating natural gases within all environments, from the surface, down into the underlying aquifers. As illustrated by this report, conducting such investigations correctly, and validating the results requires the measurement of gases in the atmosphere, the near-surface vadose zone and in deeper formations using water wells, and eventually, even to the oil and gas production wells.

ETI's soil gas data also shows the complex distribution of methane anomalies that can only be correctly delineated by sampling on a grid. The Tract 03 report provides a graphical and easily understandable example of the correct approach and methodology used by ETI in the Playa Vista investigations. This approach, which employs both vadose zone soil gases with deeper dissolved gases in the underlying aquifers defines the approach that must be followed in order to conduct meaningful phase I and II surveys. Phase I must be conducted on a grid using ETI's sampling and analysis methodology, with sub-ppmv analysis capability. Due to shallow groundwater in this area, phase II must be conducted using dissolved gas analysis made on groundwater samples obtained from monitor wells that have been placed using soil gas maps from phase I for guidance.

ETI's Playa Vista soil gas data and reports provide the best available guidance for evaluating the 2009 URS phase I soil gas data. In addition to the Tract 03 report, it would be also useful to view Plate 2-RegionalReport and Plate 3-RegionalReport from ETI's "Regional Geochemical Assessment of Methane, BTEX, CO2 and H2S Gas Occurrences" report submitted on July 10, 2001 to the Mineral Resources Division of the California Division of Oil and Gas. Plates 2 and 3 from this regional report contain methane and ethane soil gas data from the entire area of investigation, including some

overlap with the Playa Del Rey field where the more recent 2009 URS phase I report was conducted.

An examination of the URS data tables shows that no ambient (2.5 ppmv), nor sub-ambient methane concentrations were reported in the 2009 URS phase I report. In sharp contrast, the ETI data on the regional Playa Vista methane soil gas map (Plate 2) shows that background methane concentrations are often less than the atmospheric concentration of approximately 2.0 ppmv. All the URS sites have very large methane values, generally ranging from over 15 to 30 ppm, or greater. Such large methane values would mean that all of the sites are impacted by migrated methane, or that the URS methane concentrations are bottom truncated, since they are well above the typical background concentration of shallow soil gas methane. A comparison with Plate 2 from the regional ETI Playa Vista report clearly shows that the area where the URS survey was conducted contains a large number of soil gas sites where methane is at, or below the ambient methane concentration of approximately 2.0 ppm. The very large methane values in the URS report (generally greater than 15 ppmv) suggests that every one of the URS samples have been impacted by methane that could only have come from depth. The concentration of methane in the atmosphere is less than 2 ppmv, so 15 plus ppmv methane anomalies cannot be derived from the atmosphere. These anomalously large methane concentrations in the URS soil gas data suggests migration seepage from depth occurs at nearly every site. That is either true, or their methane data is invalid.

Even more problems with the URS data are obvious when one looks at their ethane and propane data. Detection limits for ethane and propane of 3 and 1.5 ppmv are much too large for mapping the normal range of natural ethane and propane soil gas anomalies. The ethane data on Plate 3 from the regional ETI Playa Vista report provides an example of the expected range for ethane, which is in the sub-ppmv concentrations in this area where the URS samples were collected. Ethane and propane are very significant to the interpretation of deep sourced gases and must be correctly detected and measured in order to meet the stated objectives of detecting deep sourced, petroleum related storage gases. A comparison of the URS data with the ETI soil gas anomalies from Plate 3 shows that ethane background concentrations are nearly always less than 0.100 ppm in the area where the URS data was collected. The larger ethane magnitudes are found only near macro seeps, which generally have a fairly small aerial footprint, where magnitudes increase rapidly from background levels to percent concentrations where the very largest concentrations are found.

This lack of adequate sensitivity is further compounded by URS using two different purge volumes for their Geoprobe samples. Sites 1 to 63 had one purge volume of 365 ml removed, while sites 64 to 150 had three purge volumes of 1095 ml removed before collecting the vapor sample. This increase from one to three purge volumes for the last 86 samples dilutes the final 86 samples with respect to the first 64 samples, further decreasing the concentrations for the smaller magnitude ethane through butanes to values that are obviously below the URS labs detection limits.



The objective for conducting soil gas surveys is to measure the naturally occurring equilibrium established between the soil gas vapors and the subsurface contamination. This equilibrium is in delicate balance (particularly in low-permeability clays) or wet sediments and is easily disturbed. Only the vapor in the sampling tools should be purged. The result in this case is that no background level methane or ethane plus hydrocarbons were found in any sample. A review of ETI's Plates 2 and 3 from the regional Playa Vista report shows the background concentrations that should have been found in, at least a few of the 2009 URS soil gas samples. Clearly, the URS analytical detection limits are far too large for measuring any of the methane, ethane, propane or butanes in the natural environment.

The only useful data obtained by the 2009 URS soil gas survey were the macro level hits at sites 64 near the Del Rey 10 well and sites 137 to 142 near the Stewart, Covington and Riegle production wells. Del Rey 10 has had documented macro level leakage on the pad around the well site for more than 30 years, however, the macro level seepage around the Stewart, Covington and Riegle production wells has not been previously reported and should be a serious concern for SoCalGas. It is interesting to note that URS recommended that this new leakage be further investigated, yet SoCalGas deleted that recommendation from the first draft of the URS report. The need to further investigate this new macro seepage was confirmed nearly two years later on Feb. 24, 2011, when water and storage gas was found to be flowing from the surface casing annulus of the Riegle 1 well, causing SoCalGas to be cited by DOGGER (Formal Order no. 1008). Pressure was reported to be building up in several wells in the vicinity of Riegle 1. No macro level leakage should ever be tolerated without an investigation of the cause.

With the exception of finding two macro seeps, the URS data and report are inadequate and do not meet the minimum Phase I requirements, to say nothing about the fact that the main premise of using a 100' X 100' grid have not been followed or even addressed. As stated in the 2009 URS phase I report, two probes were planned for each gas storage well, and less than two whenever the production wells were close together. This planned URS sample spacing is totally inadequate for finding or defining any seepage found, and obviously is inadequate or determining the size and/or shape of typical soil gas anomalies, on either a regional basis, or particularly around a deep production well where much closer spacing is required.

An example of the seepage associated with an abandoned dry hole, the Syndicate #1, can be viewed on ETI's Plates 2 and 3, on the regional Playa Vista soil gas maps. This abandoned well lies south of Jefferson and west of Lincoln Avenue. Expanded scale illustrations of methane and ethane posted in ppmv have been generated and are included Syndicate-1-well to provide a more detailed view of the seeps located near this well. ETI's soil gas site location numbers are also posted above the site symbol (cross) on the ethane map, and ethane is posted below the symbol. Note that only five samples are above the 10 ppmv methane contour interval, and only 8 samples are above the 0.5 ppmv ethane contour interval. The majority of the soil gas samples, even right next to the well are much lower in concentration, and even more importantly, the

ETI investigators did not observe any macro level seepage (i.e. bubbles) back in 2000 when the Playa Vista surveys were done. This data shows that one soil gas sample placed at random near a well is totally inadequate for determining whether that well is associated with any leakage from depth.

It is particularly significant to note that this response is associated with an abandoned dry hole that is not a gas storage well, and has never produced oil or gas. The ETI data discussed above was collected in 2001 before the well was re-abandoned by Playa Vista. Following re-abandonment the leakage around this well has significantly increased and today is reported by DOGGER to be vigorously bubbling around the casing and includes additional vents more than 100 feet away from the casing. Actual Youtube videos <http://www.youtube.com/watch?v=LR1r9X2VGZo&feature=geosearch> and <http://www.youtube.com/watch?v=NNA2f3GvUPg&NR=1>) show these gas bubbles. An excellent report on this extensive gas leakage from the Syndicate-1 well is discussed in a 12 July 2010 letter report ([Geoscience Seep Gas Analysis.pdf](#)) submitted by Lewis Pandolfi.

A similar response to this could be found around any well in the general Playa del Rey area, regardless of whether it is, or was a gas storage well, or an abandoned oil and gas well. **All old well casings are potential leakage conduits and all of the known wells, whether abandoned or not, should have been included in the planned phase I soil gas survey.** This increase in leakage activity is obviously related to the re-abandonment of the well. It can never be assumed that a re-abandonment of any well will always be successful. Follow-up soil gas surveys are the only way to prove that the re-abandonment was successful.

The number of soil gas samples has to be set by the grid requirements and cannot be arbitrarily set to only 150 total samples. In addition, the analytical laboratory has to have sub-ambient level methane (1 to 2 ppmv) and ppbv level C2+ detection capability. A valid soil vapor survey often requires additional infill samples placed on an even closer 30' to 50' spacing to validate results. This was done on several subareas at Playa Vista. The problems with the URS data become obvious when compared to the regional ETI soil gas data from the main Playa Vista report that contains actual soil gas data collected by ETI from the same area as the URS report.

In addition, as noted earlier, Phase II cannot be completed using multi-depth soil vapor stations within this particular area because groundwater will be too shallow over most of the area for the collection of soil gas from deeper soil gas probes. Phase II must include the use of dissolved and/or free gases derived from monitor wells that have been installed using the soil gas anomalies as a guide for placement. ETI's Playa Vista investigations provide examples for using this approach, where groundwater samples collected from monitor wells were used to determine the migrated hydrocarbon gases in the subsurface aquifers that are the source of the shallower soil vapor anomalies. The Phase II scope of work should also include the use of stable hydrocarbon isotopes and the measurement of helium on all samples.

Gas samples should also be collected directly from the surface casing, intermediate annulus casing and tubing at all production related wells. All wells should be included in any evaluation, regardless of whether they are producing or abandoned, including even dry holes such as the Syndicate 1, which is now become a problem well that would be very dangerous if located near any buildings. The Troxel-1, Del Rey 10 and several of the other Township wells are as likely to be vertical leakage conduits as the Syndicate-1. They could be leaking as much as the Syndicate-1, but are not obvious because they are not covered by water, which allows the bubbles to be observed. In such cases, only a soil gas survey can determine whether gas leakage is occurring.

Sincerely,  
Exploration Technologies, Inc.  
Environmental Division  
Victor T. Jones, Ph.D.

A handwritten signature in black ink that reads "V. T. Jones III". The signature is written in a cursive style with a large, stylized "J" and "I".

1 Todd T. Cardiff, Esq. (SBN 221851)  
2 LAW OFFICE OF TODD T. CARDIFF  
3 121 Broadway, Ste. 358  
4 San Diego, CA 92101  
5 Tel: (619) 546-5123  
6 Fax: (619) 546-5133

7 Attorney for Petitioners  
8 ETINA and Grassroots Coalition

9 **SUPERIOR COURT OF THE STATE OF CALIFORNIA**  
10 **COUNTY OF LOS ANGELES, CENTRAL DISTRICT**

11 ENVIRONMENTALISM THROUGH  
12 INSPIRATION AND NON VIOLENT  
13 ACTION ("ETINA") ET AL.

14 Petitioners,

15 v.

16 CITY OF LOS ANGELES, ET AL.

17 Respondents.

18 PLAYA VISTA CAPITAL, LLC, ET. AL.

19 Real Parties-in-Interest

) Case No. BS073182

) **PETITIONERS' ETINA AND**  
) **GRASSROOTS COALITION'S**  
) **ADDITIONAL OBJECTIONS TO**  
) **RETURN TO WRIT**

) Assigned for all purposes to:  
) *Hon. Ann I. Jones*  
) *Department 40*

) Hearing Date: Sept. 24, 2008 (rescheduled)  
) Hearing Time: 10:00 a.m.  
) Location: Dept. 40

20 Respectfully submitted,

21  
22  
23 DATE: August 11, 2008

24 Todd T. Cardiff, Esq.  
25 Attorney for Petitioner  
26 ETINA and Grassroots Coalition.

27  
28  
\_\_\_\_\_  
ADDITIONAL OBJECTIONS IN OPPOSITION TO RETURN TO WRIT

1 ENVIRONMENTALISM THROUGH INSPIRATION AND NON VIOLENT ACTION (“ETINA”)  
2 and GRASSROOTS COALITION (collectively "Petitioners") submit these additional objections to the  
3 City of Los Angeles' (“City”) and Playa Vista Capital, et. al. (“Playa Vista” or collectively,  
4 "Respondents") Return to Writ. Because there is some confusion as to the meaning and intent of the  
5 Court’s July 30, 2008 Minute Order denying Petitioners’ Motion to Augment the Administrative  
6 Record, and Petitioners’ subsequent ability to cite to and produce evidence demonstrating a violation of  
7 the information disclosure policies of CEQA, the first -part of this brief will address CEQA without  
8 citing to extra-record evidence. IN A SEPARATE AND SEVERABLE second part of this brief will  
9 discuss the documentary evidence that demonstrates that the City and Playa Vista failed to disclose and  
10 apparently suppressed relevant information which precluded informed decisionmaking. Petitioners’  
11 will discuss the case law precedent permits the consideration of extra-record evidence to determine  
12 whether a violation of information disclosure provisions of CEQA occurred which constitutes a  
13 prejudicial abuse of discretion. Such two-part approach will permit the court to consider or exclude  
14 the second part of the brief, without affecting the arguments in the first portion of the brief.

15 **PART I**

16 CEQA, at its very heart, is an informational process. One of the basic purposes of CEQA is to  
17 “Inform governmental decisionmakers and the public about the potential significant environmental  
18 effects of proposed activities.” (Guidelines § 15002(a)(1).)<sup>1</sup> One of the goals of an environmental  
19 impact report (EIR) is to “demonstrate to an apprehensive citizenry that the agency has in fact analyzed  
20 and considered the ecological implications of its action.” (*No Oil, supra*, 13 Cal. 3d at 86.) Thus,  
21 “[CEQA] must be open to the public, premised upon a full and meaningful disclosure of the scope,  
22 purposes, and effect of a consistently described project.” (*County of Inyo v. City of L.A.* (1984) 160  
23 Cal. App. 3d 1178, 1185.)

24 In keeping with the informational nature of CEQA, the Public Resources Code mandates:

25 Information relevant to the significant effects of a project, alternatives, and  
26 mitigation measures which substantially reduce the effects shall be made  
27 available as soon as possible by lead agencies, other public agencies, and

28 <sup>1</sup> CEQA Guidelines are located at Volume 14 of the California Code of Regulations 15000 et.seq.

1 interested persons and organizations.

2 (Pub. Res. Code § 21003.1(b).)

3 Furthermore, "CEQA protects not only the environment but informed self-government."  
4 (*Laurel Heights Improvement Assn. v. Regents of University of California* (1988) 47 Cal. 3d 376, 392  
5 (*Laurel Heights I* .) "If CEQA is scrupulously followed, the public will know the basis on which its  
6 responsible officials either approve or reject environmentally significant action, and the public, being  
7 duly informed, can respond accordingly to action with which it disagrees." (*Id.*) Obviously, CEQA  
8 cannot accomplish its purpose if either the process for obtaining information or the final document fails  
9 to accomplish its informational purpose.

10 In keeping with the informational purpose of CEQA, the public resources states that non-  
11 compliance with the informational disclosure provisions of CEQA may constitute a prejudicial abuse of  
12 discretion, regardless of whether non-compliance would have changed the decision approving or  
13 denying the project.

14  
15 [N]oncompliance with the information disclosure provisions of this division  
16 which precludes relevant information from being presented to the public agency,  
17 or noncompliance with substantive requirements of this division, may constitute  
18 a prejudicial abuse of discretion within the meaning of Sections 21168 and  
19 21168.5, regardless of whether a different outcome would have resulted if the  
20 public agency had complied with those provisions.

21 (Pub. Res. Code § 21005.)

22 "[a] prejudicial abuse of discretion occurs if the failure to include relevant information  
23 precludes informed decisionmaking and informed public participation, thereby thwarting the statutory  
24 goals of the EIR process." (*Save Our Peninsula Comm. v. Monterey County Bd. of Supervisors* (2001)  
25 87 Cal. App. 4th 99, 118; *See also, Sierra Club v. State Bd. of Forestry* (1994) 7 Cal. 4th 1215, 1235  
26 (discussing timber harvesting plans).) Because the omission of relevant information is a violation of  
27 the procedural requirements of CEQA, a harmless error analysis is inapplicable and a failure to comply  
28 is automatically an abuse of discretion. (*County of Amador v. El Dorado County Water Agency* (1999)  
76 Cal. App. 4th 931, 946; *State Water Resources Control Bd. Cases* (2006) 136 Cal. App. 4th 674,

1 723.)

2 However, not every omission, regardless of how minor, is a per se abuse of discretion. (*Association of*  
3 *Irrigated Residents v. County of Madera* (2003) 107 Cal. App. 4th 1383, 1391.)

4 “The courts have looked not for perfection but for adequacy, completeness, and a good faith effort at  
5 full disclosure” (*County of Amador, supra*, 76 Cal. App. 4th at 954.)

6 As will be discussed below, not only did the City fail to present evidence from the Department  
7 of Sanitation, it failed to inform the Regional Water Quality Control Board that it was going through a  
8 CEQA process to evaluate the impacts of dewatering activities. This failure to disclose evidence and  
9 failure to inform trustee agencies about the CEQA process prevented relevant information from being  
10 presented to the decisionmaker, in this case, the City Council. The City Council could not have made  
11 an informed decision lacking information about the extent of actual and potential dewatering activities.

12  
13 **B. The City’s Failure to Disclose and Analyze Actual Data from the**  
14 **Department of Sanitation Constitutes a Prejudicial Abuse of Discretion.**

15 The City’s Chief Legislative Analyst Report process had a very narrow scope. It was limited  
16 the scope of the review to solely "the potential for subsidence" and "exacerbation of existing  
17 groundwater contamination" caused by groundwater dewatering in connection with methane mitigation  
18 systems. (3 RR 472.)<sup>2</sup> Petitioners dispute that this is the proper scope of review. Because the court  
19 ordered the City to vacate the methane mitigation measures (not just dewatering system), the City was  
20 required to look at all issues regarding such methane systems, not just to subsidence and contamination.  
21 Nevertheless, even *assuming arguendo* that the City could narrowly limit its review of the methane  
22 mitigation measures to such specific impacts, the City failed to gather all relevant actual data to  
23 evaluate the impacts of dewatering. As such, the City abused its discretion. (Pub. Res. Code § 21005.)

24 The CLA report is very specific on what the “Peer Reviewers” reviewed. The Peer Reviewers  
25 examined the modeling study prepared by Playa Vista’s consultants, CDM, correspondence between  
26 CDM, Los Angeles Department of Building Services and the Regional Water Quality Control Board,

27  
28 <sup>2</sup> [volume] return record [page number]. Please note that the previous citation at page 4, lines 5-6 of Petitioners’  
Opposition to Return to Writ incorrectly cited to 3 RR 373. The correct citation is 3 RR 472.

1 allegedly the original EIR and the public comment. (3 RR 473-78.) What is missing is any review of  
2 actual data from the Los Angeles Department of Sanitation. There are no Department of Sanitation  
3 documents in the Record which show actual or potential permitted groundwater discharges into the City  
4 Sewer System.

5 Without reviewing existing permits and data from the Department of Sanitation, the agency  
6 responsible for accepting water from dewatering activities, there is no possibility that the CLA report  
7 complied with CEQA. "Impacts of the project must be measured against the real conditions on the  
8 ground." (*Save Our Peninsula Comm. v. Monterey County Bd. of Supervisors* (2001) 87 Cal. App. 4th  
9 99, 121 (citations omitted).) The City cannot simply rely on modeling data provided by Playa Vista,  
10 which has a vested interest in downplaying, limiting and minimizing the potential impacts of  
11 dewatering. (See *Id.* at 126 (discussing problems with relying solely on applicant generated data).)  
12 The City cannot delegate the duty to Playa Vista (or the public) to gather the necessary baseline  
13 information. (*Id.* at 122.)

14 Furthermore, the City cannot claim ignorance of the requirement to consider data from the  
15 Department of Sanitation. Afterall, the Peer Review specifically noted that the water was discharged  
16 into the sanitary sewer, and also noted that "The water disposal has been installed pursuant to an  
17 industrial waste permit issued by the Bureau of Sanitation." In other words, the Peer Reviewer knew of  
18 the availability of existing hard data, but failed to review such data.

19 Petitioners specifically requested the City review its files from the Department of Sanitation in  
20 its "Notice of Information Required for Adequate CEQA Review" (5 RR 986.) In addition, a number  
21 of comments questioned the lack of actual data from the Department of Sanitation. (See e.g., 2 RR  
22 428; 7 RR 1328; 1357.) In fact, five months before the final decision, Patricia McPherson stated at a  
23 public hearing "The Department of Sanitation has 65 - - 65 groundwater dewatering permits for the site  
24 at Playa Vista. You chose five building to look at. You didn't give [the Peer Reviewers] a fair model  
25 to begin with." (7 RR 1357:line 24 to 1358: line 3.) The City simply ignored such comment and  
26 pretended that the Department of Sanitation did not exist.

27 Respondents will likely argue, as they did in their Opposition to the Motion to Augment, that  
28 Petitioners could have obtained such data from the Department of Sanitation and included it in the



1 record. Any assertion that its Petitioners' duty to review the City's files for the project, obtain the  
2 relevant documents, and re-submit such documents back to the City for review, is patently absurd. As  
3 discussed in the Guidelines, "The Lead Agency shall not knowingly release a deficient documenting  
4 hoping that public comments will correct defects in the documents." (Guidelines § 15020.) It is the  
5 City's duty, not the public's to do the proper environmental investigation. (*Save Our Peninsula, supra*,  
6 87 Cal. App. 4th at 122; *Sundstrom v. County of Mendocino* (1988) 202 Cal. App. 3d 296, 311.) The  
7 City violated the information disclosure provisions of CEQA by not providing records from the  
8 Department of Sanitation to the City Council and the public for review.

9  
10 **C. The City Abused Its Discretion By Failing to Inform the Regional Water**  
11 **Quality Control Board of its CEQA Review and Gathering the Appropriate**  
12 **Data.**

13 Informing other governmental agencies that CEQA review is occurring is an incredibly  
14 important step in the CEQA process. Section 21080.3 of CEQA states:

15 Prior to determining whether a negative declaration or environmental impact report is  
16 required for a project, the lead agency shall consult with all responsible agencies and  
17 trustee agencies. Prior to that required consultation, the lead agency may informally  
18 contact any of those agencies.

19 (Pub. Res. Code § 21080.3(a).)

20 Obviously, such consultation will only occur if the responsible or trustee agency that it is  
21 informed that it is evaluating a project (or a portion of a project) under CEQA. There is nothing in the  
22 record which demonstrates the City informed the Regional Water Quality Control Board (RWQCB)  
23 that it was participating in a CEQA process. The failure to inform a lead or trustee agency of the CEQA  
24 process is a prejudicial an abuse of discretion. (*Fall River Wild Trout Found. v. County of Shasta*  
25 (1999) 70 Cal. App. 4th 482, 492.)

26 This is not to imply that the RWQCB did not participate in the CLA process. However, the  
27 CLA process, according to the City's was not prepared under CEQA. As noted by Attorney Susan  
28 Pfann, "There's no requirement of how you about doing [a peer review] or whether or not you have to  
senditso certain agencies...its simply a study." (2 RR 403.) In this case, the City failed to inform the  
Regional Water Quality Control Board (RWQCB) of its CEQA process, instead simply requesting the

1 RWQCB simply review Playa Vista's modeling program. Petitioners' specifically objected to the  
2 City's failure to notify the RWQCB of the process thereby triggering full CEQA review. (5 RR 943.)  
3 By solely requesting a review of the modeling study prepared by CDM, the City prevented the  
4 RWQCB from fully participating in a manner required in a CEQA review process, and violated the  
5 information disclosure requirements of CEQA. (Pub. Res. Code 21005.)

6 The City may argue that its failure to inform the RWQCB that it was participating in a CEQA  
7 process was not a prejudicial because the RWQCB did make comments. Perhaps if the City had  
8 requested all the relevant data regarding dewater at Playa Vista and Ballona Wetlands possessed by the  
9 RWQCB, the City would have an argument. However, there is no evidence in the record that the City  
10 requested even basic data, such as NPDES permits or actual metering data, despite the fact that  
11 Petitioners specifically requested the City review NPDES permits in its study of significant effects. (5  
12 RR 986.)

13  
14 **D. The City Failed to Gather or Present Data Necessary for Determining  
Whether Dewatering Activities Were Cumulatively Considerable.**

15 The lack of information from the RWQCB and Department of Sanitation is especially egregious  
16 when one considers the lack of analysis of cumulative impacts. A lead agency must determine not only  
17 direct and indirect effects of a project are significant, but must also consider whether such impacts are  
18 cumulatively significant. (Guidelines section 15064.) As noted in the case law discussing cumulative  
19 impacts, "the outcome may appear startling once the nature of the cumulative impact problem has been  
20 grasped." (*Kings County Farm Bureau v. City of Hanford* (1990) 221 Cal. App. 3d 692, 721.) The  
21 City, by limiting its review solely to the five buildings identified by Playa Vista in its modeling data,  
22 failed to consider whether all dewatering activities taken together, may be cumulatively significant.

23 Phase I of the Playa Vista Development consists of 3,426 residential units, 1.25 million square  
24 feet of office and light industrial space, 35,000 acres of retail space and 300 hotel rooms on 246.3 acres  
25 of land. ((*Environmentalism Through Inspiration and Non-Violent Action, et. al. v. City of Los*  
26 *Angeles*, 2005 Cal. App. Unpub. LEXIS 9697, at 3.) ("ETINA v. LA") Despite the massive size, there  
27 is no description in the 2007 CLA Report of how many buildings are a part of Playa Vista Phase I, nor  
28 how many buildings have dewatering systems. This data should have been easily obtainable from the

1 Department of Sanitation, which issued industrial water permits for the dewatering systems. (3 RR  
2 502.) Yet, it was not presented to the public.

3 If one were to search exhaustively through the administrative record, one would find a table  
4 described as "Construction and Vesting Status of Playa Vista Phase I" that was apparently submitted by  
5 Playa Vista on the date of the hearing. (2 RR 226.) The table identifies 39 Buildings in the "west end  
6 of the first phase" (2 RR 226-29.) Of those 39 buildings identified by Playa Vista, 18 of such  
7 buildings are identified as having "ground-water dewatering system" Yet, the table fails to identify  
8 how much dewatering is occurring at each site. Such information is crucial to knowing whether the  
9 dewatering at Playa Vista is cumulatively considerable.

10 In addition, other dewatering activities independent of buildings must be evaluated to determine  
11 whether there is a significant impact. It was incumbent on the City to request dewatering data from the  
12 RWQCB, the agency responsible for managing the states' water. Despite petitioners' request that such  
13 data be evaluated, there is no indication in the record that the City requested such information from the  
14 RWQCB. (3 RR 486.)

15 Of course, as indicated by the description as "Playa Vista Phase I", there is also Playa Vista  
16 Phase II. Despite this well-known fact, there is no analysis in the 2007 CLA report of Phase II. The  
17 2007 CLA report indicates that the peer reviewers solely reviewed reports analyzing the potential  
18 impacts installed in Phase I of the Playa Vista development. (3 RR 473.) There is no analysis of the  
19 dewatering activities expected in Phase II of the Playa Vista Development.

20 For a proper analysis of the potential cumulative impacts requires an analysis of all dewatering  
21 activities at Playa Vista. This information is available from the RWQCB. But, the City failed to  
22 request such information. There is not information in the record which describes NPDES permits of  
23 the Playa Vista site or actual discharge volumes into Ballona Wetlands. Without providing the total  
24 volume of all dewatering activities, neither the City nor the public can properly evaluate or participate  
25 in the public process.

26 **CONCLUSION**

27

28

1 The failure to obtain data concerning actual dewatering data from the Department of Sanitation  
2 and the RWQCB constitutes a prejudicial abuse of discretion under CEQA. (Pub. Res. Code § 21005.)  
3 The 2007 CLA report fails as an informational document. Such document

4 **PART II**

5 There is a genuine confusion as to the meaning of the Court's ruling on July 30, 2008 denying  
6 the Motion to Augment. The Court refused to augment the administrative record with the documents  
7 because they were not before the City Council at the time of the final decision. However, the Court  
8 also indicated in oral argument that such ruling was without prejudice to Petitioners' ability to bring  
9 such arguments under CEQA. What is unclear is whether Petitioners ability to bring such arguments in  
10 our additional objections, included the right to refer and cite to the documents excluded from the  
11 administrative record to establish non-compliance with the information disclosure requirements of  
12 CEQA. (Pub. Res. Code § 21005.) Petitioners were unable to obtain a transcript of the hearing in time  
13 to resolve the dispute, and the court was unavailable for clarification of the issue.

14 It is absolutely clear by reviewing the actual documents that the failure to obtain or provide the  
15 documents Petitioners' sought to augment constitutes an omission of relevant material. Because  
16 prejudice is not presumed under Public Resources Code section 21005(b), it is important for the court  
17 to consider the actual documents to determine whether the failure to include relevant information  
18 precludes informed decisionmaking and informed public participation.

19 The court should consider that CEQA is not intended to be a cat and mouse game, with the lead  
20 agency and applicant attempting to avoid evidence which contradicts its predetermined decision to  
21 approve the project. CEQA only functions when there is good faith effort at compliance and full  
22 disclosure. It is simply too great of a burden to expect the public to divine that the City and applicant are  
23 going to refuse to gather the relevant data. It is simply too great of a burden to expect the public to make  
24 up for the failure of the City to conduct the proper environmental investigation. The City cannot  
25 submit a legally deficient document hoping that the public will cure the deficiencies, or fail to identify  
26 the deficiencies. (Guidelines § 15020.)

1                   **A. Evidence From the Los Angeles Department of Sanitation and the Regional**  
2                   **Water Quality Control Board Demonstrates the City and Playa Vista**  
3                   **Violated Information Disclosure Requirements of CEQA.**

4                   Public Resources Code section 21005 states,

5                                 [N]oncompliance with the information disclosure provisions of this division  
6                                 which precludes relevant information from being presented to the public agency .  
7                                 . . may constitute a prejudicial abuse of discretion.

8                   There a number of ways that an applicant or a lead agency may fail to comply with the  
9                   information disclosure requirements. (See e.g. *Fall River Wild Trout Found. v. County of Shasta*  
10                   (1999) 70 Cal. App. 4th 482, 493 (failing to notify DFG); *Cadiz Land Co. v. Rail Cycle* (2000) 83 Cal.  
11                   App. 4th 74, 95 (failing to identify size of aquifer); *Sierra Club v. State Bd. of Forestry* (1994) 7 Cal.  
12                   4th 1215 (failing to study endangered species); *Save Our Peninsula, supra*, 87 Cal. App. 4th at 122  
13                   (failing to use actual data.) In fact, many cases which have sought to strike down environmental  
14                   impact reports have sought to establish, through omission, that there has been non-compliance with the  
15                   information disclosure requirements of CEQA. (*Association of Irrigated Residents v. County of Madera*  
16                   (2003) 107 Cal. App. 4th 1383, 1391.)

17                   However, suppression of evidence is also a form of non-compliance. Evidence which clearly  
18                   should be in the record, but has been improperly excluded, should be admissible to demonstrate a  
19                   violation of Public Resources Code section 21005. Clearly evidence which has been withheld from the  
20                   public, despite requests from the public for inclusion of such information, cannot be provided by the  
21                   public. In addition, the public should be able to assume the lead agency will include documents which  
22                   are required to be part of the administrative record under CEQA, such as documents in its own files on  
23                   a project. (Pub. Res. Code 21167.6(e)(10).)

24                   Such interpretation is supported by *Western States* which notes that extra-record evidence  
25                   should be admissible to demonstrate procedural unfairness and agency misconduct. (*Western States*  
26                   *Petroleum Ass'n v. Superior Court* (1995) 9 Cal. 4th 559, 575 n.5 & 579.) In *Western States*, the  
27                   petroleum association attempted to introduce newly created expert evidence, prepared after the close of  
28                   the public hearing, to demonstrate that the Air Resources Board failed to consider all relevant factors.  
The Supreme Court held, "extra-record evidence can never be admitted merely to contradict the

1 evidence the administrative agency relied on in making a quasi-legislative decision or to raise a  
2 question regarding the wisdom of that decision." In contrast, in this case Petitioners seek the court to  
3 consider documents which were in the agency's files or trustee agency's files to demonstrate a  
4 procedural defect in the City's CLA process.

5 In this case, there is extra-record evidence from the Department of Sanitation which  
6 demonstrates that the level of dewatering is almost five-fold greater than that which was presented in  
7 Playa Vista's modeling study. (Notice of Lodgment, Ex. 1.)<sup>3</sup> Petitioners specifically requested such  
8 documents in the CLA process (5 RR 986.) The assertion that the public must independently dig  
9 through the City's own files to ensure that a spider maps of phase I and phase II is before the  
10 decisionmaker violates CEQA policies which places the duty of environmental investigation squarely  
11 on the shoulders of the responsible governmental agency. (Guidelines § 15020; *Sundstrom, supra*, 202  
12 Cal. App. 3d at 311.) Obviously, information about the actual state of dewatering in the City's own  
13 files on the Playa Vista would be critical to informed decision-making. Such documents were required  
14 to be part of the record under CEQA. (Pub. Res. Code § 21167.6(e)(10).)

15 Even more egregious is the failure of the City to request and Playa Vista's failure to disclose  
16 evidence of NPDES permits in existence at the time of the hearing. Documents from the RWQCB  
17 demonstrate that 950,000 gallons a day of dewatering is occurring at the Playa Vista Site. (Exhibit 2.)  
18 As evidenced by the 2003 permit number on page 2 of the document, such evidence was available to  
19 Playa Vista long before the 2007 CLA Report was adopted.

20 Respondents may attempt to argue that such dewatering is independent of the methane  
21 mitigation system. Such statement would be untrue. As it states in the document, "The area proposed  
22 for dewatering under this permit is located at least 800 feet from the areas of known or suspected  
23 contamination." If dewatering is not occurring for the purpose of groundwater remediation, then it  
24 must be dewatering for the purpose of lowering the groundwater table, and therefore in connection with  
25 methane mitigation measures. In addition, the permit requires Playa Vista to maintain a settling tank,  
26

27  
28 <sup>3</sup> The documents attached to the Notice of Lodgment have been previously authenticated by Patricia McPherson's  
declaration filed in conjunction with the Motion to Augment. Plaintiffs Request Judicial Notice of such declaration pursuant  
to Evidence Code section 452d. Respondents never objected to the authenticity of such documents.

1 bag filter, activated carbon and Zeolite treatment in case the pumping encounters contamination. In  
2 other words, the RWQCB is concerned about expansion of the groundwater contamination...the same  
3 potential impact identified by the Court of Appeal. (*Environmentalism Through Inspiration and Non-*  
4 *Violent Action, et. al. v. City of Los Angeles*, 2005 Cal. App. Unpub. LEXIS 9697, at 36.)

5 The documents from the Department of Sanitation are unquestionably part of the City's file on  
6 the Playa Vista project and should have been made available to the City Council and the Public. (Pub.  
7 Res. Code section 21167.6(e)(10). The failure to present such evidence to the public and City Council  
8 precluded informed decisionmaking and public participation and therefore violated CEQA. (Pub. Res.  
9 Code § 21005.) The documents from the RWQCB demonstrate that up to 950,000 gallons a day of  
10 dewatering is occurring at the Playa Vista site. Playa Vista, by failing to submit such relevant  
11 information to the decisionmaker, violated the information disclosure provisions of CEQA. (Pub. Res.  
12 Code 21003.1.) The suppression of such documents cannot be considered a good faith effort at full  
13 disclosure. The Return to Writ must be denied.

14  
15  
16  
17  
18  
19  
20  
21  
22  
23  
24  
25  
26  
27  
28

BERNARD ENDRES, PH.D.  
3045 TUNA CANYON ROAD  
TOPANGA, CA 90290

3

---

TELEPHONE (310) 455-0023 \* FACSIMILE (310) 455-3618

15 February 2001

CITY OF LOS ANGELES  
DEPARTMENT OF BUILDING & SAFETY  
201 N. Figueroa, 3rd Floor  
Los Angeles, CA 90012

ATTENTION: DANA PREVOST

Re: REGIONAL GROUND SUBSIDENCE AT PLAYA VISTA,  
PLAYA DEL REY AND THE MARINA PENINSULA, AND  
RELATED GAS MIGRATION PROBLEMS

Dear Mr. Prevost:

Pursuant to your recent request, I have prepared this letter as a review of issues regarding regional ground subsidence and the related gas migration issues in Playa Vista, Playa del Rey and the Marina Peninsula areas.

1. SUBSIDENCE IS CAUSED BY FLUID WITHDRAWAL:

Fluid withdrawal from a petroleum reservoir or aquifer leads to the inevitable result of causing land subsidence at the surface, and compaction of sands at the reservoir level. The compaction is due to a pressure decrease in the reservoir or aquifer, and causes the overlying formations and the land surface to sink. This deformation leads to fracturing of the geological formations in the surrounding areas, causes movement along existing fault structures, and damages the oil and gas well casings and seals. This gives rise to the upward migration of gas from the petroleum reservoir. The interaction between subsidence and gas migration is illustrated in Exhibit 1.

The geological deformation is greatest at the reservoir level and propagates to the surface as a bowl shaped configuration, as illustrated in Exhibit 2. The maximum subsidence is at the center of the bowl. For a petroleum reservoir, the extent of the subsidence bowl at the surface is approximately twice the areal extent of the reservoir. The cross-sectional distribution of compressive and tensile stresses within the subsiding formation is also illustrated in Exhibit 2.

As a general rule, the amount of subsidence experienced at the surface correlates directly with the volume of fluid production within the reservoir. A convenient representation is to plot cumulative subsidence versus time, and cumulative fluid production versus time in order to characterize this correlation. The survey data and fluid production history of the referenced area supports this correlation.



2. FLUID WITHDRAWAL HAS CAUSED SIGNIFICANT SUBSIDENCE AT PLAYA VISTA, PLAYA DEL REY AND THE MARINA PENINSULA AREAS:

Fluid production of oil and brine water from the Playa del Rey and Venice oil fields caused nearly two feet of surface subsidence between 1927 and 1970. The California Division of Oil and Gas (DOG) documented this in their Sixtieth Annual Report published in 1974. Exhibit 3 presents the iso-contours of subsidence from that report, showing the vertical movement in feet during 1937 to 1970 (viz., Figure 3 from the DOG report). This figure also illustrates the productive limits of the "Del Rey Hills Area," the "Venice Area" and the "Kidson Area."

Exhibit 4 presents the cumulative subsidence in feet for the time period 1927 to 1970 for selected bench marks, along with cumulative oil field production (viz., Figure 4 from the DOG report). These data support the following conclusions:

1. Surface subsidence directly correlates with the fluid production from the oil fields.
2. Surface subsidence directly correlates with the productive limits of the oil fields.
3. The areal extent of the subsidence extends well beyond the productive limits of the oil fields.
4. Subsidence was continuing unabated at the end of the measurement data in 1970.

Although fluid production from these areas has continued to the present time, subsidence monitoring has been ignored. Southern California Gas Company (SOCALGAS) has operated an extensive oil field dewatering program within the "Del Rey Hills Area" and the "Venice Area" for many years. This has been necessary since the gas storage operations requires continuous pumping of brine water from these areas to prevent invasion of the water into the primary storage zone reservoir.

The average daily production from their dewatering wells is approximately 2,500 barrels of brine water per day. This would equate to over 90,000 barrels per year, or over 27 million barrels of fluid production between 1970 and the present. It is inevitable that this has contributed to the subsidence problem, additional geological fracturing, and additional damage to the oil and gas well casings and seals.

3. CITY OF LOS ANGELES SURVEY DATA HAS CONFIRMED THE EXISTENCE OF A SERIOUS SUBSIDENCE PROBLEM:

I utilized survey data generated by the City of Los Angeles to evaluate the extent of the subsidence problem in the Playa Vista Area (near Jefferson Blvd. and Lincoln Blvd.) in the vicinity of the Playa del Rey oil field. The data utilized is presented in Exhibit 5.

The elevation data for a bench mark at Jefferson and Lincoln was as follows ("STD SUR MON, VEN I-4, ON CENTER LINE INTER OF JEFFERSON BLVD AND LINCOLN BLVD. \*\* GONE 1972 \*\*"):

Exhibit 6 sets forth the location of the oil and gas wells within the Playa del Rey and Venice oil field areas. These areas are all interconnected with a highly permeable gravel zone that was formed by the old Los Angeles Riverbed. This provides a ready conduit for the migration of gas as it leaks up the old and corroded well casings. These wells were drilled prior to the time that significant subsidence had occurred in the oil fields. Accordingly, this subsidence has aggravated the well leakage problems.

SOCALGAS owns all of the mineral rights in this area, and has been the oil field operator for many years. As a consequence, they have the primary responsibility for monitoring for oil field subsidence, but have not done so. Furthermore, they have failed to adequately investigate the integrity of the many old wells in the area, and have failed to perform adequate soil gas studies.

It is apparent that the gas migration problems at Playa Vista are strongly interrelated with the movement of leaking gas easterly within these gravel zones as a result of being "swept" by the tidal forces and wave energy within these permeable zones.

5. SURFACE DEFORMATION:

Deformation due to compression and extension at and near the land surface causes fissures in the soil and damages buildings, pipelines, and other structures. In the subject areas, these problems are complicated by the 100% liquefaction prone region that has been identified in the Seismic Hazards Map published by the Division of Mines and Geology, and by the near surface water table.

Regional water tables will remain at nearly the same elevation after local subsidence lowers the land surface. The effect is to decrease the depth to the water level. If the water table rises (relative to the land surface), higher than the bottom slab of a building, the uplift pressure on the structure will be noticeably increased. This could cause the slab to eventually rupture.

Likewise, the below-slab installation of a gas membrane barrier for gas control purposes could be adversely impacted by these same uplift pressure conditions. Since the gas membrane must perform without failure over the lifetime of the structure (viz., exceeding 70 years), the long-term consequences of the subsidence must be evaluated. As a minimum, this would require ongoing monitoring of the subsidence problem using dedicated bench marks and appropriate surveying techniques.

These survey techniques have been implemented successfully in many oil fields throughout the world. For example, the city of Long Beach requires continuous monitoring for subsidence in the Wilmington Field, and has an elaborate water injection program to mitigate the consequences of surface sinking and water incursion in this coastal area.



The city of Beverly Hills has imposed a contractual obligation upon all oil field operators within the city to monitor for subsidence. This has been ongoing for at least the past 50 years, when it was first imposed upon the Occidental Petroleum operations within the city.

The city of Redondo Beach failed to impose such a requirement on oil field operations conducted under the King Harbor Boat Marina. Approximately two feet of subsidence, which occurred over a period of 20 years of oil production, caused the breakwater rubble barrier, constructed by the U.S. Army Corps of Engineers, to sink. A winter storm in 1988 destroyed the rubble barrier, and the city of Redondo Beach and the U.S. Army Corps of Engineers were held liable for the millions of dollars of damage that resulted to the shoreline structures. They were found to have been negligent for failing to monitor for the subsidence and for their failure to take protective measures to minimize the risk of injury.

It is significant to point out that the level of subsidence measured in the Playa del Rey and Venice coastal areas through 1970 is similar to the subsidence that caused the destruction of the King Harbor at Redondo Beach. However, it is alarming that this profound example of destruction has largely gone ignored as it relates to the Playa Vista development.

The conduct of SOCALGAS in failing to monitor for subsidence over the past 30 years falls well below the standard of care for oil field operators. In addition, their refusal to perform appropriate soil gas surveys in the area has endangered public health and safety.

6. LESSONS LEARNED REGARDING SUBSIDENCE PROBLEMS THAT CAUSED THE COLLAPSE OF THE BALDWIN HILLS DAM:

Another example of oil field related subsidence that deserves careful review is the failure of the Baldwin Hills Dam on December 14, 1963. This facility was designed, constructed and operated by the Department of Water and Power. It was an earthen dam that was constructed over the Inglewood oil field, and used a spray-on membrane barrier similar to the "liquid boot" product. The basic design was flawed because it failed to account for the moving and unstable soil conditions created by the subsiding oil field operated by Chevron.

The reservoir failed so abruptly that there was not enough time to evacuate all of the people located in the area. The foundation of the dam and the membrane barrier lining ruptured and within hours the reservoir was empty. Five persons drowned, 41 homes were destroyed and another 986 homes were severely damaged. The dam purportedly had a monitoring system capable of detecting leakage of water into the area below the membrane barrier.

An investigation conducted after the dam collapse revealed that land subsidence and soil movement had created tears in the membrane barrier, allowing some water to escape and undermine the integrity of the dam's earthen foundation. These studies also revealed that the subsidence was not uniform, and caused differential settling across the diagonal face of the dam. None of this movement was monitored or accounted for in the design of the dam.

These lessons learned are especially significant as they relate to the gas membrane barrier installed at the Fountain Park apartment complex. There has been no showing that this membrane barrier will have the capability to withstand the geological and hydrostatic forces that can be anticipated to exist over the lifetime of the structure.

The problems can be viewed as the reverse of what caused the Baldwin Hills Dam disaster. Gas cannot be allowed to leak upward through the membrane barrier. However, the membrane barrier must survive the forces caused by a combination of movements from earthquake liquefaction, oil field subsidence, multiple piling penetrations, and the upward pressures from a shallow water table.

The pilings and stone columns have already been demonstrated to exacerbate the gas migration problem, placing even greater importance on this problem area.

#### 7. MONITORING REQUIREMENTS:

The following conditions require monitoring and evaluation of their interrelations:

1. Surface vertical and horizontal deformations performed by leveling surveys, to be conducted on an ongoing basis.
2. An evaluation of fluid production being carried out by SOCALGAS, with an identification of well locations and production zones.
3. An evaluation of gas seepage from well locations utilizing soil gas monitoring techniques.
4. An evaluation of the hydrology conditions existing within the gravel aquifers within the vicinity of the oil and gas wells.
5. An evaluation of the dynamic conditions of the water table and other piezometric surfaces, including the influences of tidal action and seasonal variations.
6. An evaluation of the mechanical condition and well leakage information for all of the oil and gas wells located in the Playa del Rey and Venice oil fields.
7. Development of a gas mitigation and earthquake risk assessment plan consistent with the problems identified by this investigation.

The cost burden for these studies should be the responsibility of SOCALGAS. They have responsibility for the safe operation of the Playa del Rey and Venice oil fields by virtue of being the successor in interest to the operations of these fields that first began in the late 1920's. Also, SOCALGAS has derived, and continues to derive, significant economic benefit by the continued operation of these fields as part of their gas storage operations.

It is critical that SOCALGAS be required to disclose all well record information that is within their possession. This is necessary to protect public health and safety, and to facilitate an independent review of the risks posed by their operations. For example, there is overwhelming evidence that SOCALGAS failed to disclose to the DOG, and to the public, important information regarding well leakage problems. Also, they have falsely represented to the city of Los Angeles that there is no vertical gas migration at Playa del Rey.

8. THERE IS A HUGE INCOMPATIBILITY BETWEEN SOCALGAS OPERATIONS AND RESIDENTIAL DEVELOPMENT:

SOCALGAS currently has an application pending before the State of California Public Utilities Commission (PUC) seeking authorization to sell certain residential lots within the Playa del Rey and Marina Peninsula areas. Previously they had sold many residential lots in these areas without obtaining approval from the PUC. The validity of these sales, and possible violations of PUC regulations is currently under review by the PUC.

In many instances, these lot sales have resulted in homes being built directly over old oil and gas wells. SOCALGAS has taken the position that the city of Los Angeles is solely responsible for the permitting and approval procedures regarding this residential development. On the other hand, SOCALGAS has failed to disclose the serious leakage problems they have experienced with these wells. Most of the wells that were proclaimed to have been abandoned to the current standards of the DOG have developed leaks.

There has been a failure to evaluate the long-term consequences of subsidence, well leakage problems and earthquake hazards on these real estate developments. This responsibility has been delegated to the city of Los Angeles by SOCALGAS without adequate disclosure of the public health and safety risks posed by their operations. As a consequence, virtually no mitigation measures have been imposed by the city, and no monitoring procedures have been required.

The SOCALGAS underground gas storage operation in the city of Montebello had to be shut down because of well leakage problems into homes. Some homes had to be torn down to provide access to the leaking wells. In addition, homes built over the wells prevented appropriate monitoring of the gas migration hazards.

Before additional housing construction is allowed in the Playa Vista, Playa del Rey and Marina Peninsula areas a thorough investigation of the hazards to public health and safety must be performed. This is dictated by the City of Los Angeles Building Code which is primarily intended to protect the residents in these areas who have little or no knowledge of the extreme dangers posed by these oil field operations.

9. CONCLUSIONS:

Fluid withdrawal from the Playa del Rey and Venice oil fields has created regional ground subsidence that has impacted, and will continue to impact, real estate developments at Playa Vista, Playa del Rey and the Marina Peninsula areas. Nearly two feet of subsidence occurred between 1927 and 1970. However, there has been no systematic monitoring for subsidence since 1970.

This is an ongoing problem since SOCALGAS continues to produce large volumes of brine water from many wells in the area as part of their underground gas storage operations.

The subsidence has caused fracturing of the geological formation and damage to the well casings causing upward migration of gas to the surface, thereby exacerbating the near surface soil gas problems.

The long-term consequences of the surface deformation will impact the integrity of the gas membrane barriers necessary to protect structures from the migrating gas.

A systems engineering approach is necessary in evaluating the interactive consequences of subsidence, gas migration and movement of gas through the near surface aquifers from the locations of the leaking wells. This requires a detailed evaluation of the hydrology and the tidal actions that are responsible for moving the gases easterly within the aquifers and under the Playa Vista development.

There is an urgent need for SOCALGAS to disclose all of the well record information within their possession in order to facilitate an independent investigation of the public health and safety risks posed by the oil field and gas storage operations.

A monitoring program needs to be initiated that would systematically evaluate the subsidence and gas migration problems on a regional basis in order to properly assess the hazardous conditions.

Sincerely yours,



Bernard Endres, Ph.D.

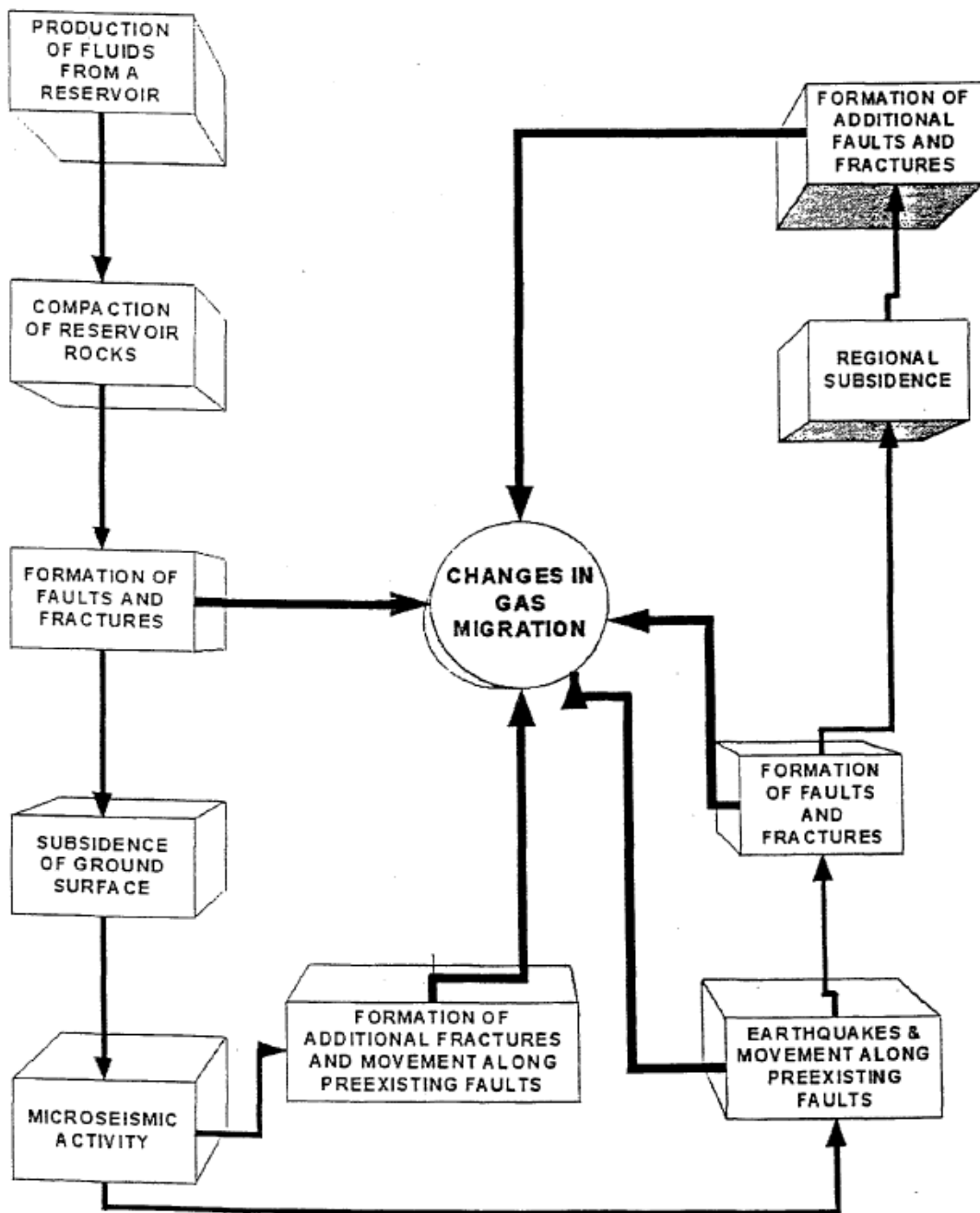
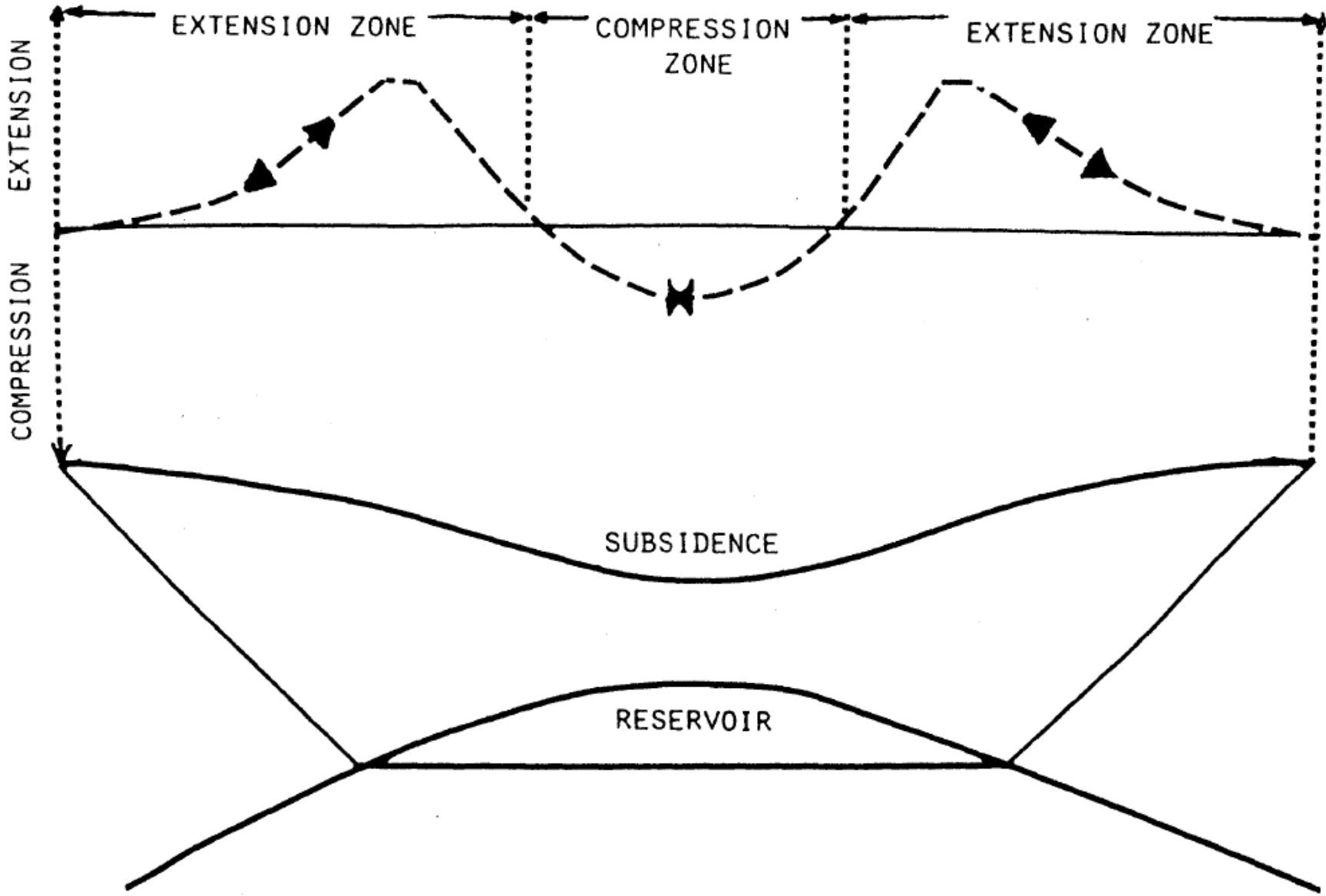

Figure 21-1. Schematic diagram of system relationships among the production of fluids, compaction, subsidence, and seismic activity. (Modified after Chilingarian et al., 1995, fig. 1, p. 41.)





compressive and tensile stress distribution in subsiding formations.

### ELASTIC DISTORTION AND COMPRESSION

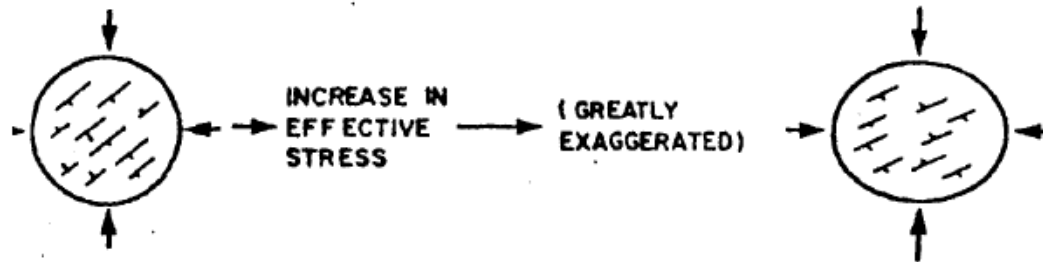

### CONTACT POINT COMPRESSION AND YIELD

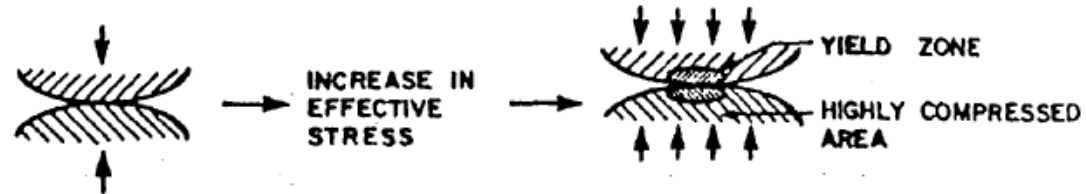

### GRAIN REARRANGEMENT

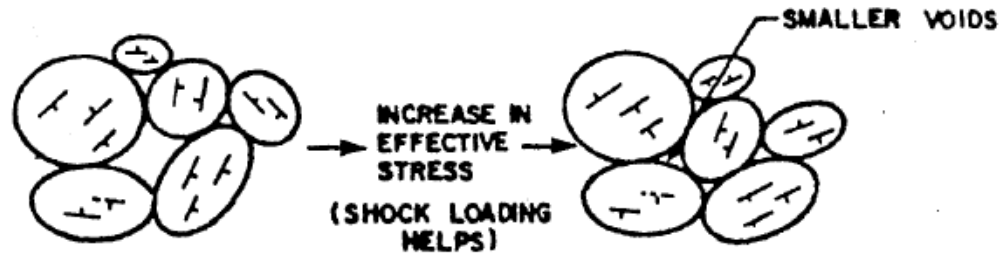

### SOLUTION RECRYSTALLIZATION

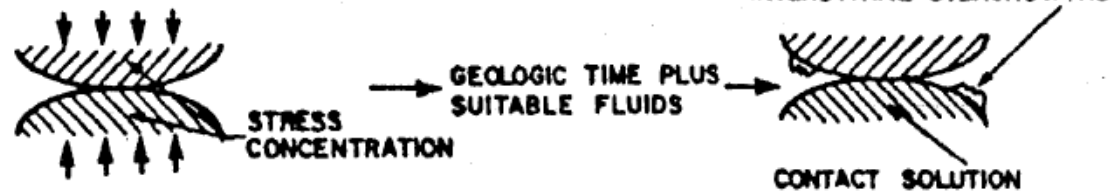

## Mechanisms of volume decrease

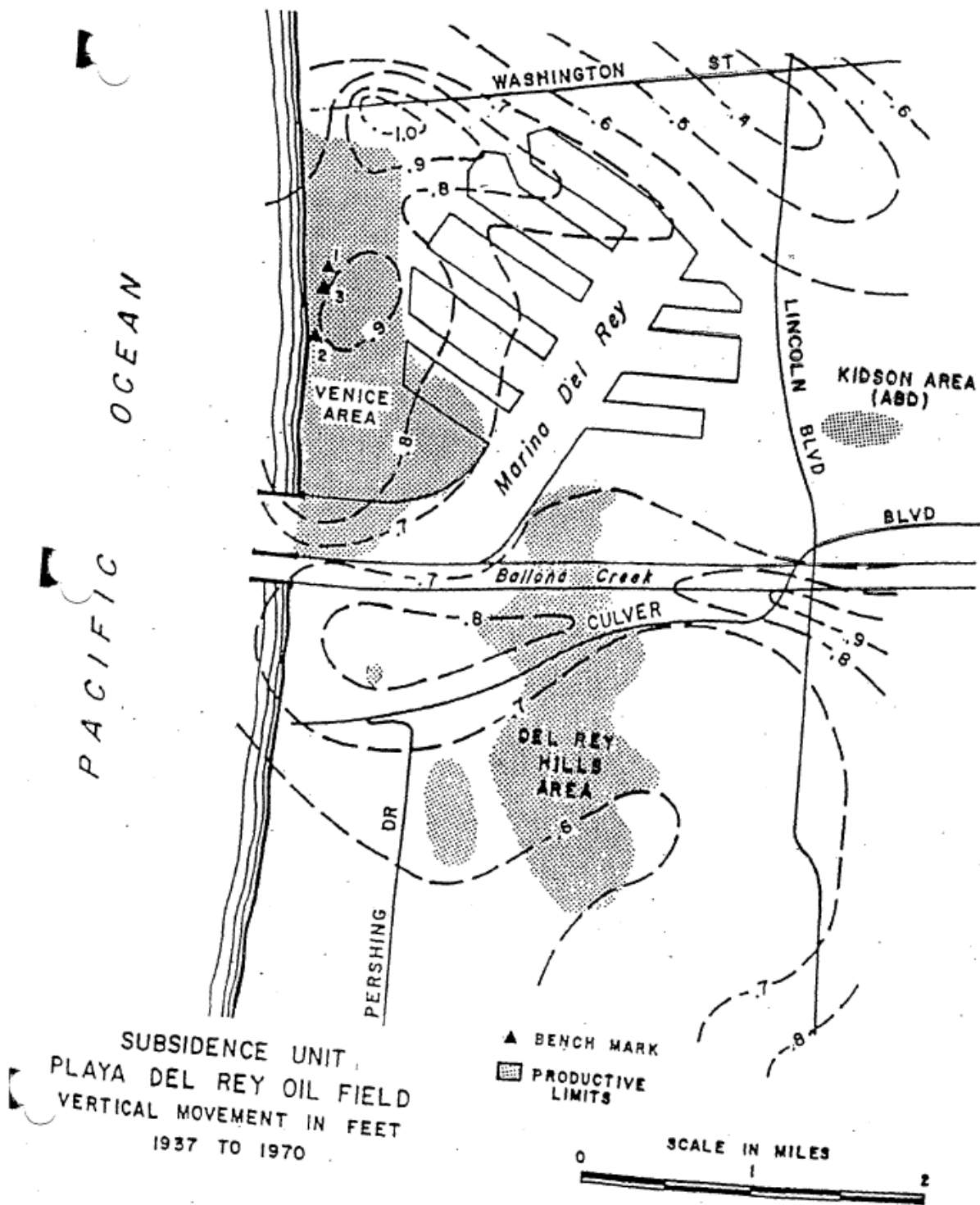

Figure 3

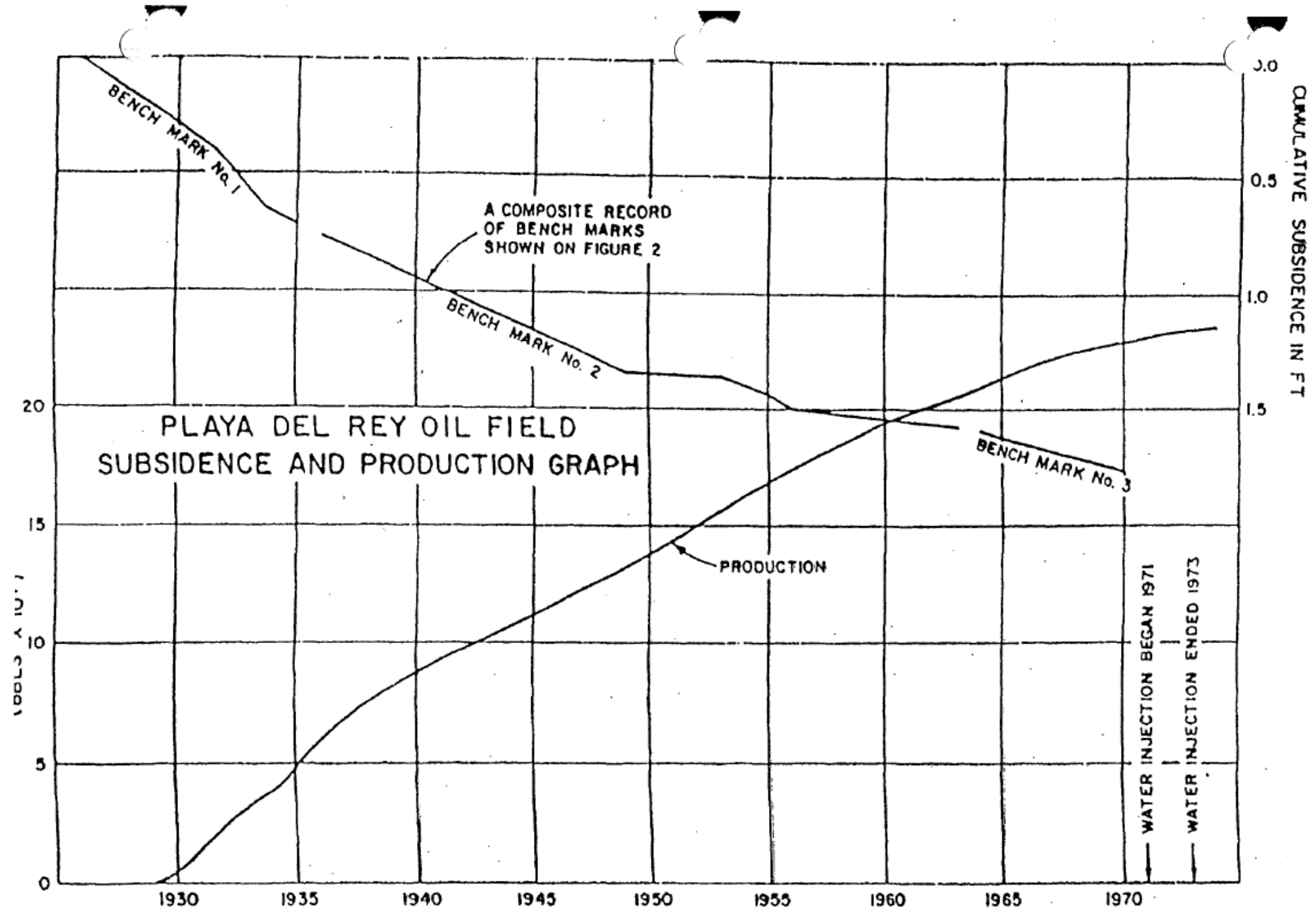

Figure 4

|                                                                                                                                                                        | ELEV                  | TR | ELEV                   | TR | ELEV                   | TR | ELEV                   | TR | BM                     | N      |
|------------------------------------------------------------------------------------------------------------------------------------------------------------------------|-----------------------|----|------------------------|----|------------------------|----|------------------------|----|------------------------|--------|
| ST. R. MON, SAW J-12, ON CENTER LINE INTERSECTION OF MCLAUGHLIN AVE & WASHINGTON PL                                                                                    | 366.70<br>(18.400)    |    | 60.414 68P<br>(18.414) |    | 60.526 63S<br>(18.448) |    |                        |    |                        | 17-108 |
| SPK N CURB MCLAUGHLIN AVE, 3FT W/O BCR WASHINGTON PL                                                                                                                   | 61.932 85<br>(18.877) |    | 61.850 80<br>(18.852)  |    |                        |    |                        |    |                        | 17-108 |
| WIRE SPK IN SE CURB HERBERT ST, 6FT NE OF BC CURB RETURN NE OF MCLAUGHLIN AVE                                                                                          | 54.101 85<br>(16.490) |    | 53.989 80<br>(16.456)  |    | 54.140 70<br>(16.502)  |    | 54.187 68P<br>(16.516) |    | 54.299 63S<br>(16.550) | 17-108 |
| STD SUR MON, SAW J-12A, ON CENTER LINE MCLAUGHLIN AVENUE, 48.30FT NORTHWEST OF CENTER LINE WASHINGTON BLVD.                                                            | 44.012 85<br>(13.415) |    | 43.914 80<br>(13.385)  |    | 44.050 70<br>(13.426)  |    | 44.097 68P<br>(13.441) |    | 44.212 63S<br>(13.476) | 17-108 |
| WIRE SPK IN E CURB OF W RDWY CULVER BLVD, 4.8FT S OF N CURB LINE PRODUCED, OF MCLAUGHLIN AV, N END CB                                                                  | 38.966 80<br>(11.877) |    | 39.097 70<br>(11.917)  |    | 39.143 68P<br>(11.931) |    | 39.257 63S<br>(11.966) |    |                        | 17-109 |
| SPK 2FT E/O E CURB OF WEST BDWY CULVER BLVD, 12FT N/O C/L PROD MCLAUGHLIN AVE, N END CB                                                                                | 39.058 85<br>(11.905) |    |                        |    |                        |    |                        |    |                        | 17-109 |
| STD SUR MON, VEN K-1, ON CENTERLINE INTER OF CULVER BLVD EAST ROADWAY AND SLAUSON AVENUE, FROM THE EAST.                                                               | 37.006 70<br>(11.279) |    | 37.051 68P<br>(11.293) |    | 37.166 63S<br>(11.328) |    |                        |    |                        | 17-109 |
| LACO FC DISK *STMPD 116-20300, 1971* 2FT W/O WEST CURB CULVER BLVD, 9.5FT N/O NORTH ABUT OF FLOOD CONTROL CHANNEL, N END GUARD RAIL, APPROX 150FT S/O SLAUSON AVE EAST | 39.278 85<br>(11.972) |    | 39.180 80<br>(11.942)  |    |                        |    |                        |    |                        | 17-109 |
| WIRE SPK IN E CURB CULVER BLVD, 1.6FT S OF BC CURB RETURN S OF STONER AVE                                                                                              | 36.037 85<br>(10.984) |    | 35.938 80<br>(10.954)  |    | 36.072 70<br>(10.995)  |    | 36.116 68P<br>(11.008) |    | 36.232 63S<br>(11.044) | 17-109 |
| SPK N CURB INGLEWOOD BLVD, 10FT E/O BCR CULVER BLVD, EAST RDWY                                                                                                         | 35.026 85<br>(10.676) |    | 34.924 80<br>(10.645)  |    |                        |    |                        |    |                        | 17-109 |
| STD SUR MON, VEN J-1B, ON CENTER LINE INTERSECTION CULVER BLVD E RDWY & INGLEWOOD BLVD                                                                                 | 35.090 70<br>(10.695) |    | 35.134 68P<br>(10.709) |    | 35.247 63S<br>(10.743) |    |                        |    |                        | 17-109 |
| WIRE SPK IN E CURB CULVER BLVD, 0.6FT S OF BC CURB RETURN S OF FARIAS AVE                                                                                              | 30.197 85<br>(9.204)  |    | 30.108 80<br>(9.177)   |    | 30.247 70<br>(9.219)   |    | 30.290 68P<br>(9.232)  |    | 30.405 63S<br>(9.267)  | 17-109 |
| WIRE SPK IN W CURB CULVER BLVD W RDWY, 11.8FT N OF BC CURB RETURN N OF WESTLAWN AVE, S END CB                                                                          | 22.871 85<br>(6.971)  |    | 22.772 80<br>(6.941)   |    | 22.898 70S<br>(6.979)  |    |                        |    |                        | 17-110 |

(METRIC IN PARENTHESES)

|                                                                                                                                                                                                                               | ELEV    | TR  | ELEV    | TR  | ELEV    | TR  | ELEV    | TR  | DM      | NO         |
|-------------------------------------------------------------------------------------------------------------------------------------------------------------------------------------------------------------------------------|---------|-----|---------|-----|---------|-----|---------|-----|---------|------------|
| SPK IN CURB CULVER BLVD, WEST RDWY, 24FT N/O<br>MASCAGNI STREET N END CB                                                                                                                                                      | 19.445  | 85  | 19.347  | 80  |         |     |         |     |         | 17-1102    |
|                                                                                                                                                                                                                               | (5.927) |     | (5.897) |     |         |     |         |     |         |            |
| STD SUR MON, VEN J-2A, ON CENTER LINE CULVER BLVD<br>EAST ROADWAY, 49FT SOUTH OF CENTER LINE PRODUCED<br>OF MASCAGNI STREET                                                                                                   | 18.527  | 70  | 18.568  | 68P | 18.692  | 63S |         |     |         | 17-1103    |
|                                                                                                                                                                                                                               | (5.647) |     | (5.660) |     | (5.697) |     |         |     |         |            |
| WIRE SPK IN E CURB CULVER BLVD E RDWY, 38.3FT<br>N OF BC CURB RETURN N OF BRADDOCK DR, N END CB<br>** GONE 1976 **                                                                                                            | 17.044  | 70S |         |     |         |     |         |     |         | 17-1104    |
|                                                                                                                                                                                                                               | (5.195) |     |         |     |         |     |         |     |         |            |
| SSM ON C/L INTER CULVER BLVD ELY RDWY & BRADDOCK DR                                                                                                                                                                           | 15.200  | 70  | 15.241  | 68P | 15.365  | 63S |         |     |         | 17-1105    |
|                                                                                                                                                                                                                               | (4.633) |     | (4.645) |     | (4.683) |     |         |     |         |            |
| WIRE SPK IN N CURB MCCONNELL AVE, 2.6FT W<br>OF BC CURB RETURN W OF CULVER BLVD, W RDWY                                                                                                                                       | 15.043  | 85  | 14.947  | 80  | 15.072  | 70S |         |     |         | 17-1106    |
|                                                                                                                                                                                                                               | (4.585) |     | (4.556) |     | (4.594) |     |         |     |         |            |
| STD SUR MON, VEN I-2, ON THE INTER OF CENTER LINE<br>CULVER BLVD AND CENTER LINE PRODUCED OF BEETHOVEN<br>STREET, 4FT SOUTH OF MOST SOUTHERLY CURB LINE<br>PRODUCED OF SEARS SERVICE CENTER LOCATED AT #12870<br>CULVER BLVD. | 12.363  | 70  | 12.404  | 68P | 12.517  | 63S |         |     |         | 17-1107    |
|                                                                                                                                                                                                                               | (3.768) |     | (3.781) |     | (3.815) |     |         |     |         |            |
| WIRE SPK IN E CURB CULVER BLVD, 7FT N OF SLY DRIVE<br>WAY TO BLDG #12870, 0.15MI SLY FROM MCCONNELL AVE                                                                                                                       | 13.173  | 85  | 13.077  | 80  | 13.208  | 70S |         |     |         | 17-1108    |
|                                                                                                                                                                                                                               | (4.015) |     | (3.986) |     | (4.026) |     |         |     |         |            |
| WIRE SPK N CURB CULVER BLVD, 1 FT E OF BC CURB<br>RETURN E OF OFF RAMP HWY 90 GOING EAST<br>EAST BOUND ON RAMP                                                                                                                | 12.615  | 85  | 12.526  | 80  | 12.655  | 70S |         |     |         | 17-1109    |
|                                                                                                                                                                                                                               | (3.845) |     | (3.818) |     | (3.857) |     |         |     |         |            |
| BOLT IN ELY CORNER OF CONC BASE OF CROSSING SIGNAL<br>AT NW SIDE OF CULVER BLVD ABOUT 135FT SW OF ALLA RD<br>13FT N OF P.E. RR TRACKS, 27FT SE OF S.P. RR TRACKS<br>** GONE 1973 **                                           | 12.874  | 63S |         |     |         |     |         |     |         | 17-1110    |
|                                                                                                                                                                                                                               | (3.924) |     |         |     |         |     |         |     |         |            |
| STD SUR MON, VEN I-3A, ON CENTER LINE CULVER BLVD,<br>0.12MI WESTERLY FROM FREEWAY 90, 55FT NORTH OF<br>POWER POLE #32912M.                                                                                                   | 8.606   | 70  | 8.647   | 68P | 8.764   | 63S |         |     |         | 17-1111    |
|                                                                                                                                                                                                                               | (2.623) |     | (2.636) |     | (2.671) |     |         |     |         |            |
| BOLT IN W CURB LINCOLN BLVD, 52FT<br>S OF BC CURB RETURN S OF FIJI WAY                                                                                                                                                        | 8.940   | 85  | 8.848   | 80  | 9.030   | 75  | 8.918   | 74S | 8.948   | 74P17-1115 |
|                                                                                                                                                                                                                               | (2.725) |     | (2.697) |     | (2.752) |     | (2.718) |     | (2.727) |            |

(METRIC IN PARENTHESES)

P 98

|                                                                                                                                                     | ELEV    | YR | ELEV    | YR | ELEV    | YR  | ELEV    | YR  | BM      | N         |
|-----------------------------------------------------------------------------------------------------------------------------------------------------|---------|----|---------|----|---------|-----|---------|-----|---------|-----------|
| BRA DISC *STMPD L.A.CO ENGINEER R.E. 7078* IN CONC MON, UNDER COVER, ON APPARENT CTR LINE INTERS OF FIJI WAY & ADMIRALTY WAY, IN THE MARINA COMPLEX | 15.440  | 80 | 15.622  | 75 | 15.518  | 74S | 15.554  | 74P | 15.562  | 70R17-115 |
|                                                                                                                                                     | (4.706) |    | (4.762) |    | (4.730) |     | (4.741) |     | (4.743) |           |

|                                                                                                                                                                   |         |    |  |  |  |  |  |  |  |        |
|-------------------------------------------------------------------------------------------------------------------------------------------------------------------|---------|----|--|--|--|--|--|--|--|--------|
| BOAT SPK IN THE INTER OF FIJI WY & ADMIRALTY WY, 0.7FT E OF BOAT SPK ON C/L EC, STA 17 PLUS 15.00, OF FIRST CURVE IN FIJI WY W OF LINCOLN BLVD<br>** GONE 1969 ** | 16.438  | 63 |  |  |  |  |  |  |  | 17-115 |
|                                                                                                                                                                   | (5.010) |    |  |  |  |  |  |  |  |        |

|                                                                                      |         |    |  |  |  |  |  |  |  |        |
|--------------------------------------------------------------------------------------|---------|----|--|--|--|--|--|--|--|--------|
| BRASS NAIL IN LEAD N CURB FIJI WAY, 1FT W/O BCR W/O ADMIRALTY WAT ** NOTE MILEAGE ** | 16.440  | 85 |  |  |  |  |  |  |  | 17-115 |
|                                                                                      | (5.011) |    |  |  |  |  |  |  |  |        |

|                                                                                                                                                                                  |         |    |         |    |         |     |         |     |  |        |
|----------------------------------------------------------------------------------------------------------------------------------------------------------------------------------|---------|----|---------|----|---------|-----|---------|-----|--|--------|
| BRASS DISC *STMPD L.A.CO ENGINEER R.E. 7078* IN CONC MON, UNDER COVER, ON APPARENT CTR LINE 0.14MI W OF ADMIRALTY WAY, OPPOSITE DRVWY ENTRANCE TO FISHERMANS VILLAGE PARKING LOT | 13.392  | 80 | 13.580  | 75 | 13.511  | 74P | 13.519  | 70R |  | 17-115 |
|                                                                                                                                                                                  | (4.082) |    | (4.139) |    | (4.118) |     | (4.121) |     |  |        |

|                                                                                                        |         |    |  |  |  |  |  |  |  |        |
|--------------------------------------------------------------------------------------------------------|---------|----|--|--|--|--|--|--|--|--------|
| SPK 1FT N/O N CURB FIJI WAY, 6FT E/O DRIVE TO FISHERMANS VILLAGE, W END CB<br>0.14MI W/O ADMIRALTY WAY | 14.137  | 85 |  |  |  |  |  |  |  | 17-115 |
|                                                                                                        | (4.309) |    |  |  |  |  |  |  |  |        |

|                                                                                                                                                                                                                 |         |    |         |    |         |    |         |     |         |           |
|-----------------------------------------------------------------------------------------------------------------------------------------------------------------------------------------------------------------|---------|----|---------|----|---------|----|---------|-----|---------|-----------|
| USC&GS BM DISC *STMPD TIDAL NO. 4 1968* IN FIJI WAY 0.7FT N OF NLY CURB LINE, 138FT W OF WLY CURB LINE OF ENTRANCE TO FISHERMANS VILLAGE, W END CB<br>0.50MI WLY FROM ADMIRALTY WAY<br>0.64MI W/O ADMIRALTY WAY | 12.713  | 85 | 12.615  | 80 | 12.790  | 75 | 12.681  | 74S | 12.710  | 74P17-116 |
|                                                                                                                                                                                                                 | (3.875) |    | (3.845) |    | (3.898) |    | (3.865) |     | (3.874) |           |

|                                                                                                                                                                                      |         |    |         |    |         |    |         |     |         |           |
|--------------------------------------------------------------------------------------------------------------------------------------------------------------------------------------|---------|----|---------|----|---------|----|---------|-----|---------|-----------|
| USC&GS BM DISC *STMPD TIDAL NO. 5 1967* IN FIJI WAY IN CTR OF CURB RETURN AT S END OF MEDIAN; 53FT S OF CTR LINE DRVWY FOR PIECES OF EIGHT RESTAURANT<br>42.7FT E OF W CURB FIJI WAY | 14.774  | 85 | 14.695  | 80 | 14.869  | 75 | 14.764  | 74S | 14.798  | 74P17-116 |
|                                                                                                                                                                                      | (4.503) |    | (4.479) |    | (4.532) |    | (4.500) |     | (4.510) |           |

|                                                                                                                                                                                           |         |    |         |    |         |    |         |     |         |           |
|-------------------------------------------------------------------------------------------------------------------------------------------------------------------------------------------|---------|----|---------|----|---------|----|---------|-----|---------|-----------|
| USC&GS BM DISC *STMPD TIDAL NO. 2 1967* IN FIJI WAY IN CTR OF CURB RETURN N END OF MEDIAN, 28FT S OF CTR LINE OF W DRVWY ENTRANCE TO ADMINISTRATION PARKING LOT, 0.69MI W/O ADMIRALTY WAY | 15.226  | 85 | 15.131  | 80 | 15.310  | 75 | 15.198  | 74S | 15.232  | 74P17-117 |
|                                                                                                                                                                                           | (4.641) |    | (4.612) |    | (4.666) |    | (4.632) |     | (4.643) |           |

|                                                                                                                                                                                                                  |         |    |         |    |         |    |         |     |         |           |
|------------------------------------------------------------------------------------------------------------------------------------------------------------------------------------------------------------------|---------|----|---------|----|---------|----|---------|-----|---------|-----------|
| USC&GS DISC * STMPD TIDAL NO. 1 1967 * IN NORTHEAST CORNER OF COAST GUARD BUILDING IN CONCRETE FOUNDATION; 29.5FT WEST OF CENTER FIJI WAY, 17FT SOUTH OF CENTER LINE OF DRIVE WAY NORTH OF COAST GUARD BUILDING. | 14.728  | 85 | 14.593  | 80 | 14.759  | 75 | 14.641  | 74S | 14.657  | 74P17-117 |
|                                                                                                                                                                                                                  | (4.489) |    | (4.448) |    | (4.499) |    | (4.463) |     | (4.467) |           |

(METRIC IN PARENTHESES)

P. 985

PG 22

|                                                                                                                                                                                                                  | ELEV    | YR  | ELEV    | YR  | ELEV    | YR  | ELEV    | YR      | ELEV    | YR  | BM   |
|------------------------------------------------------------------------------------------------------------------------------------------------------------------------------------------------------------------|---------|-----|---------|-----|---------|-----|---------|---------|---------|-----|------|
| L A CO F C DISK IN TOP OF SW PIER TO OIL DERRICK,<br>67.5FT W OF CENTER LINE SPEEDWAY AND 37.5FT N OF<br>CENTER LINE PROD 46TH AVE<br>** GONE 1963 **                                                            | 16.459  | 60  | 16.502  | 56  | 16.569  | 55  | (5.017) | (5.050) | (5.050) |     | 17-0 |
| SPK W CURB PACIFIC AV 5FT N/O BCR N/O LIGHTHOUSE ST                                                                                                                                                              | 13.199  | 85  | (4.023) |     |         |     |         |         |         |     | 17-0 |
| USC & OS DISK MARKED P-767-1945 SET IN S CURB OF<br>BRIDGE 26.7FT E OF CENTER LINE ROADWAY OF PACIFIC<br>AVE, 8FT S OF CENTER LINE PRODUCED, OF LIGHTHOUSE<br>ST. X3.5FT E OF W END OF BRIDGE<br>** GONE 1986 ** | 14.682  | 70  | 14.789  | 63  | 14.827  | 60  | 14.877  | 56      | 14.947  | 55  | 17-0 |
|                                                                                                                                                                                                                  | (4.475) |     | (4.508) |     | (4.519) |     | (4.535) |         | (4.556) |     |      |
| STD SUR MON, VEN E-4, AT CENTER LINE INTER OF<br>PACIFIC AVENUE AND LIGHTHOUSE STREET.                                                                                                                           | 12.249  | 70R | 12.247  | 70  | 12.354  | 63  | 12.391  | 60      | 12.440  | 56  | 17-0 |
|                                                                                                                                                                                                                  | (3.733) |     | (3.733) |     | (3.765) |     | (3.777) |         | (3.792) |     |      |
| L.A. CFCD STEEL PIN IN LEAD, IN N CURB CULVER BLVD,<br>20.5FT E OF W BUILDING LINE OF APARTMENT COMPLEX<br>AT #405, 0.09MI WLY FROM NICHOLSON STREET                                                             | 4.042   | 85  | 3.947   | 80  | 4.110   | 75  | 4.022   | 74S     | 4.043   | 74P | 17-0 |
|                                                                                                                                                                                                                  | (1.232) |     | (1.203) |     | (1.253) |     | (1.226) |         | (1.232) |     |      |
| BOLT 1FT S/O S CURB CULVER BLVD, 49FT W/O<br>BCR NICHOLSON ST, W END CB                                                                                                                                          | 3.973   | 85  | 3.868   | 80  |         |     |         |         |         |     | 17-0 |
|                                                                                                                                                                                                                  | (1.211) |     | (1.179) |     |         |     |         |         |         |     |      |
| WIRE SPIKE IN SOUTH CURB CULVER BLVD, 54FT WEST OF<br>CENTER LINE NICHOLSON STREET.<br>** GONE 1972 **                                                                                                           | 4.038   | 70  | 4.077   | 68P | 4.169   | 63  | 4.222   | 60      | 4.270   | 56  | 17-0 |
|                                                                                                                                                                                                                  | (1.231) |     | (1.243) |     | (1.271) |     | (1.287) |         | (1.301) |     |      |
| STD SUR MON, VEN G-5A, IN CULVER BLVD, 14FT SOUTH<br>OF CENTER STRIPE, ON CENTER LINE P.I., OPPOSITE PP<br>#1277854E, 512.7FT EAST OF CENTER LINE NICHOLSON<br>STREET, 0.37MI WEST OF JEFFERSON BLVD.            | 3.236   | 75  | 3.145   | 74S | 3.162   | 74P | 3.154   | 70R     | 3.171   | 70  | 17-0 |
|                                                                                                                                                                                                                  | (0.986) |     | (0.959) |     | (0.964) |     | (0.961) |         | (0.967) |     |      |
| STD SUR MON, VEN H-4, AT CENTER LINE INTER OF<br>CULVER BLVD AND JEFFERSON BLVD.                                                                                                                                 | 4.690   | 75  | 4.579   | 74S | 4.604   | 74P | 4.595   | 70R     | 4.608   | 70  | 17-0 |
|                                                                                                                                                                                                                  | (1.430) |     | (1.396) |     | (1.403) |     | (1.401) |         | (1.405) |     |      |
| PBM DISC STAMPED * 17-02311, 1979 * CTR HEADWALL,<br>7FT S/O S EDGE PAVEMENT JEFFERSON BLVD,<br>12FT ELY C/L INTERSECTION CULVER BLVD                                                                            | 5.548   | 85  | 5.482   | 80  |         |     |         |         |         |     | 17-0 |
|                                                                                                                                                                                                                  | (1.691) |     | (1.671) |     |         |     |         |         |         |     |      |

(METRIC IN PARENTHESES)

P



(SAT.) JUNE 17, 2020, 5:15 P.M.

PACIFIC AVE  
AND LIGHTHOUSE

| <u>YR.</u> | <u>ELEVATION</u> |
|------------|------------------|
| 55         | 14.947           |
| 56         | 14.877           |
| 60         | 14.827           |
| 63         | 14.789           |
| 70         | 14.682           |

$$\Delta = \frac{14.947 - 14.682}{15 \text{ YRS.}} = \boxed{.265} \text{ FT}$$

|                                                                                                                                                                                                                                                                        | ELEV     | YR | ELEV     | YR  | ELEV     | YR  | ELEV     | YR  | ELEV     | YR  | BM    |
|------------------------------------------------------------------------------------------------------------------------------------------------------------------------------------------------------------------------------------------------------------------------|----------|----|----------|-----|----------|-----|----------|-----|----------|-----|-------|
| STD SUR MON, VEN J-5C, AT CENTER LINE INTER OF<br>LINCOLN BLVD AND 83RD STREET.                                                                                                                                                                                        | 131.653  | 75 | 131.587  | 74P | 131.585  | 70R | 131.605  | 70  | 131.642  | 68P | 17-01 |
|                                                                                                                                                                                                                                                                        | (40.128) |    | (40.108) |     | (40.107) |     | (40.113) |     | (40.124) |     |       |
| SPK 1FT W/O W CURB LINCOLN BLVD, 10FT N/O C/L EC,<br>400FT N/O 83RD ST, N END CB                                                                                                                                                                                       | 94.787   | 85 |          |     |          |     |          |     |          |     | 17-01 |
|                                                                                                                                                                                                                                                                        | (28.891) |    |          |     |          |     |          |     |          |     |       |
| STD SUR MON, VEN J-5B, IN CONC MON ON CENTER LINE<br>P.I. OF LINCOLN BLVD FROM THE SOUTH, 0.22MI NORTH<br>OF CENTER LINE 83RD STREET, 62.3FT NORTH OF A L&T<br>IN EAST CURB ON CENTER LINE TANGENT SOUTH, 65.4FT<br>SOUTHEAST OF L&T IN NORTHEAST CURB * BAR DAMAGED * | 80.981   | 80 | 81.166   | 75  | 81.102   | 74P | 81.093   | 70R | 81.113   | 70  | 17-01 |
|                                                                                                                                                                                                                                                                        | (24.683) |    | (24.739) |     | (24.720) |     | (24.717) |     | (24.723) |     |       |
| SQ SPIKE IN W CURB LINCOLN BLVD 14.8FT S OF BC<br>TO RDWY NEAR L A CITY LINE 0.55 MILES<br>S OF JEFFERSON BLVD<br>** GONE 1969 **                                                                                                                                      | 51.086   | 63 | 51.154   | 60  | 51.196   | 56  | 51.250   | 55  | 51.293   | 53  | 17-02 |
|                                                                                                                                                                                                                                                                        | (15.571) |    | (15.592) |     | (15.605) |     | (15.621) |     | (15.634) |     |       |
| SSM ON CTR LINE LINCOLN BLVD, 27FT N OF N CURB LINE<br>PROD OF N.O.S SERVICE ROAD TO THE EAST                                                                                                                                                                          | 46.381   | 85 | 46.316   | 80  | 46.502   | 75  | 46.432   | 74P | 46.422   | 70R | 17-02 |
|                                                                                                                                                                                                                                                                        | (14.137) |    | (14.117) |     | (14.174) |     | (14.152) |     | (14.149) |     |       |
| SQUARE SPK IN CULVERT HEADWALL, 50FT PLUS OR MINUS<br>W OF C/L LINCOLN BL, 53FT S OF C/L PROD OF ROAD TO<br>HUGHES AIRCRAFT. 0.28MI S OF JEFFERSON BLVD                                                                                                                | 6.988    | 85 | 6.913    | 80  | 7.094    | 75  | 7.017    | 74P | 7.003    | 70R | 17-02 |
|                                                                                                                                                                                                                                                                        | (2.130)  |    | (2.107)  |     | (2.162)  |     | (2.139)  |     | (2.135)  |     |       |
| STD SUR MON, VEN I-4, ON CENTER LINE INTER OF<br>JEFFERSON BLVD AND LINCOLN BLVD.<br>** GONE 1972 **                                                                                                                                                                   | 6.790    | 70 | 6.828    | 68P | 6.945    | 63  | 7.006    | 60  | 7.057    | 56  | 17-02 |
|                                                                                                                                                                                                                                                                        | (2.070)  |    | (2.081)  |     | (2.117)  |     | (2.135)  |     | (2.151)  |     |       |
| CITY OF L.A. SURV PBM *STMPD 17-02492 1973*<br>2FT E OF E CURB LINE OF LINCOLN BLVD, 19.4FT N<br>OF BC CURB RETURN N OF JEFFERSON BLVD, N END CB                                                                                                                       | 11.841   | 85 | 11.811   | 80  | 12.008   | 75  | 11.908   | 74S | 11.949   | 74P | 17-02 |
|                                                                                                                                                                                                                                                                        | (3.609)  |    | (3.600)  |     | (3.660)  |     | (3.630)  |     | (3.642)  |     |       |
| WIRE SPK IN CULVERT HEADWALL, 49.5FT E/O C/L<br>LINCOLN BLVD 45FT S OF CENTER LINE JEFFERSON BLVD<br>** GONE 1968 **                                                                                                                                                   | 6.752    | 63 | 6.814    | 60  | 6.864    | 56  | 6.921    | 55  | 6.964    | 53  | 17-02 |
|                                                                                                                                                                                                                                                                        | (2.058)  |    | (2.077)  |     | (2.092)  |     | (2.110)  |     | (2.123)  |     |       |
| LA CO FC DISC MARKED BM-115-228 SET IN HAND RAIL<br>BASE AND ON E SIDE OF HAND RAIL 0.7FT N OF N<br>ABUTMENT OF LINCOLN BLVD BRIDGE OVER BALLONA CREEK<br>0.26MI NLY FROM JEFFERSON BLVD *CDH BRIDGE #53 118*                                                          | 19.610   | 85 | 19.521   | 80  | 19.589   | 74S | 19.624   | 74P | 19.618   | 70R | 17-02 |
|                                                                                                                                                                                                                                                                        | (5.977)  |    | (5.950)  |     | (5.971)  |     | (5.981)  |     | (5.980)  |     |       |
| CITY OF L.A. DISC IN W FACE OF MOST NLY COLUMN OF<br>ABANDONED RR BRIDGE OVER LINCOLN BLVD. 4.5FT E OF E<br>CURB, 0.33MI N OF JEFFERSON BLVD *STMPD T 977*                                                                                                             | 12.864   | 80 | 13.054   | 75  | 12.939   | 74S | 12.972   | 74P | 12.967   | 70R | 17-02 |
|                                                                                                                                                                                                                                                                        | (3.921)  |    | (3.979)  |     | (3.944)  |     | (3.954)  |     | (3.952)  |     |       |

(METRIC IN PARENTHESES)

JEFFERSON AND  
LINCOLN  $\frac{6.17}{100}$   
 $5:37 PM$

|    |        |                      |
|----|--------|----------------------|
| 56 | 7.057  |                      |
| 60 | 7.0065 |                      |
| 63 | 6.945  | 7.006                |
| 68 | 6.828  | 6.790                |
| 70 | 6.790  | .216<br>IN<br>10 YRS |

AS SERIOUS AS  
PACIFIC LIGHTHOUSE

7.057

6.790

$$A = .267 \text{ FT/14 YRS}$$

.216/10 YRS

| PG                                                                                                                                                                                                                  | ELEV    | YR  | ELEV    | YR  | ELEV    | YR  | ELEV    | YR  | ELEV    | YR  | BM     | NI |
|---------------------------------------------------------------------------------------------------------------------------------------------------------------------------------------------------------------------|---------|-----|---------|-----|---------|-----|---------|-----|---------|-----|--------|----|
| STD TRAV MON * STMPD VEN H-3 1951 * IN LINCOLN BLVD<br>OF W EDGE CONC PVMT, 25FT N OF C/L OF DRVNY TO<br>PIER 1 IMPORTS. 256FT N/N CURB FIJI WAY. VEN H3 1951                                                       | 6.570   | 75  | 6.457   | 74S | 6.486   | 74P | 6.506   | 70  | 6.545   | 68P | 17-025 |    |
|                                                                                                                                                                                                                     | (2.003) |     | (1.968) |     | (1.977) |     | (1.983) |     | (1.995) |     |        |    |
| SPK S CURB MINDANAO WAY, 0.4FT E/O<br>BCR LINCOLN BL, W END CB                                                                                                                                                      | 8.553   | 85  | 8.455   | 80  |         |     |         |     |         |     | 17-025 |    |
|                                                                                                                                                                                                                     | (2.607) |     | (2.577) |     |         |     |         |     |         |     |        |    |
| STD TRAV MON * STMPD VEN H-3A 1951 * IN LINCOLN<br>BLVD, 1.5FT EAST OF WEST EDGE CONCRETE PAVEMENT,<br>4FT NORTH OF PP #110719M, 4FT NORTH OF PP #1277914E<br>0.10MI NORTH OF MINDANAO WAY.                         | 8.644   | 75  | 8.527   | 74S | 8.556   | 74P | 8.573   | 70  | 8.613   | 68P | 17-025 |    |
|                                                                                                                                                                                                                     | (2.635) |     | (2.599) |     | (2.608) |     | (2.613) |     | (2.625) |     |        |    |
| CUT SPK IN CULVERT HEADWALL 49FT W OF CENTER<br>LINE LINCOLN BLVD 22FT S OF CENTER LINE PERRY TRACK<br>1FT S OF N END OF HEADWALL, 0.09MI N OF BALI WAY<br>** GONE 1975 **                                          | 13.119  | 74P | 13.138  | 70  | 13.178  | 68P | 13.271  | 63  | 13.324  | 60  | 17-025 |    |
|                                                                                                                                                                                                                     | (3.999) |     | (4.004) |     | (4.017) |     | (4.045) |     | (4.061) |     |        |    |
| USC&GS BM DISC *STMPD N 1217 1971* IN W HEADWALL,<br>1.5FT S OF N END, OF CONCRETE CULVERT, 6.7FT W OF<br>W CURB LINE LINCOLN BLVD, 0.26MI NLY FROM MINDANAO<br>WAY, 33FT N OF NLY RAIL OF OLD S.P. TRAN. CO. TRACK | 14.022  | 85  | 13.921  | 80  | 14.104  | 75  | 13.994  | 74S |         |     | 17-025 |    |
|                                                                                                                                                                                                                     | (4.274) |     | (4.243) |     | (4.299) |     | (4.265) |     |         |     |        |    |
| STD TRAV MON * STMPD VEN G-2B 1951 * IN LINCOLN<br>BLVD. 1.5FT WEST OF EAST EDGE CONCRETE PAVEMENT, IN<br>FRONT OF BRICK BUILDING #4305 12FT NORTH OF POWER P<br>#110709M, 0.12MI NORTH OF P.E RR RIGHT OF WAY.     | 14.639  | 74P | 14.650  | 70  | 14.691  | 68P | 14.784  | 63  | 14.826  | 60  | 17-026 |    |
|                                                                                                                                                                                                                     | (4.462) |     | (4.465) |     | (4.478) |     | (4.506) |     | (4.519) |     |        |    |
| SPK W CURB LINCOLN BLVD, 2FT S/O BCR<br>E/O MAXELLA AVE                                                                                                                                                             | 16.329  | 85  |         |     |         |     |         |     |         |     | 17-026 |    |
|                                                                                                                                                                                                                     | (4.977) |     |         |     |         |     |         |     |         |     |        |    |
| STD SUR MON, VEN G-2C, IN LINCOLN BLVD 5FT WEST OF<br>CENTER LINE, 25.5FT NORTH OF SOUTH PROP LINE<br>PRODUCED OF MAXELLA AVENUE, TO THE WEST.                                                                      | 15.184  | 80  | 15.373  | 75  | 15.260  | 74S | 15.291  | 74P | 15.301  | 70  | 17-026 |    |
|                                                                                                                                                                                                                     | (4.628) |     | (4.686) |     | (4.651) |     | (4.661) |     | (4.664) |     |        |    |
| USC&GS BM DISC *STMPD V 977 1964* W CURB LINCOLN<br>BLVD, 4.8FT N OF N LINE BLDG #4111, S END OF MOST<br>SLY OF TWO CULVERTS, 0.37MI N OF P.E. RR R/W<br>** GONE 1973 **                                            | 13.969  | 70  | 14.010  | 68P |         |     |         |     |         |     | 17-026 |    |
|                                                                                                                                                                                                                     | (4.258) |     | (4.270) |     |         |     |         |     |         |     |        |    |
| WIRE SPIKE IN W CURB LINCOLN BLVD 0.2 MILES<br>S OF WASHINGTON BLVD N END CULVERT<br>& 47FT N/O POLE #240834M<br>** GONE 1973 **                                                                                    | 13.990  | 70  | 14.031  | 68P | 14.120  | 63  | 14.157  | 60  | 14.210  | 56  | 17-026 |    |
|                                                                                                                                                                                                                     | (4.264) |     | (4.277) |     | (4.304) |     | (4.315) |     | (4.331) |     |        |    |

(METRIC IN PARENTHESES)

P 98

SPK IN E END CB ON N'LY SIDE NOS SERVICE ROAD 81 85 17-18470  
0.64 MI W/O BM #27-18400, 244 PLUS 50 (16.240)

SSM ON C/L P.I. N.O.S AT THE INTERS OF SERVICE RD 51.749 80 51.966 75 51.882 74P 51.894 70R 51.917 70 17-18500  
AND ROAD TO RADAR TOWER ON THE HILL, 146FT E OF E (15.773) (15.839) (15.814) (15.817) (15.824)  
END OF CB, 10.5FT S OF N FLOW LINE OF RD  
0.76MI W OF BM 17-18400, STA 234 PLUS 49.33

SPK IN E END CB ON N'LY SIDE NOS SERVICE ROAD 53.320 85 17-18500  
0.82MI W/O BM #17-18400, 234 PLUS 40 (16.252)

SPK IN E END CB ON N'LY SIDE NOS SERVICE ROAD 53.100 85 17-18520  
0.93MI W/O BM #17-18400, 229 PLUS 00 (16.185)

SPK IN E END CB ON N'LY SIDE SERVICE ROAD 51.306 85 17-18540  
1.02MI W/O BM #17-18400, 224 PLUS 25 (15.638)

COPPER WIRE IN D.H. IN E RIM OF MH IN CTR OF 52.372 80 52.476 74P 52.478 70R 52.495 70 17-18550  
SERVICE RD, 1.09MI W OF BM #17-18400 (15.963) (15.995) (15.995) (16.000)  
263FT N OF C/L TANGENT N.O.S. STA 219 PLUS 63.76  
\* RESET 1975 \*

SPK IN E END CB ON N'LY SIDE NOS SERVICE ROAD 50.541 85 17-18560  
1.13MI W/O BM #17-18400, 217 PLUS 30 (15.405)

SSM IN CTR OF SERVICE RD, 115.1FT W OF SPK IN E END 48.756 80 48.944 75 48.865 74P 48.863 70R 48.882 70 17-18600  
OF CB, 1.19MI W OF BM #17-18400 (14.861) (14.918) (14.894) (14.893) (14.899)  
STA 213 PLUS 71.46

2.5IN DISC IN N SIDE AT THE CENTER OF CONG 55.951 75 55.882 74P 55.874 70R 55.844 70 17-18750  
STRUCTURE, INSIDE 5FT WIRE FENCE ENCLOSURE, 350FT (17.054) (17.033) (17.030) (17.021)  
S OF SSM OF 1ST ANGLE PT IN CENTINELA AVE, W OF  
SEPULVEDA BLVD \*C/L N.O.S. 313 PLUS 33.30\*  
\*\*FROM THIS POINT PEG UP A WIDE DIRT RD TO THE TOP  
OF HILL, THEN LEFT TO END OF SPUR\*\*

SSM ON C/L N.O.S. @ STA 308 PLUS 88.32, ABOUT 750FT 123.464 74P 123.451 70R 123.430 70 17-18770  
S OF FIRST C/L ANGLE PT IN CENTINELA AVE WEST OF (37.632) (37.628) (37.621)  
SEPULVEDA BLVD, 270FT N OF W END OF 20FT CB AT THE  
INTERSECTION OF RIGGS PL & KENTWOOD AVE, ON WLY  
PRODUCTION OF CTR LINE OF CONCRETE WALK AT N SIDE  
OF ARIZONA CIRCLE, 4FT SW OF SHOULDER OF SLOPE  
\* ABANDONED 1976 \*

(METRIC IN PARENTHESES)

P 989

PG 08

|                                                                                                                                                                                                                                                                                                                                                                  | ELEV     | YR  | ELEV     | YR  | ELEV     | YR  | ELEV     | YR  | ELEV     | YR  | BM    |
|------------------------------------------------------------------------------------------------------------------------------------------------------------------------------------------------------------------------------------------------------------------------------------------------------------------------------------------------------------------|----------|-----|----------|-----|----------|-----|----------|-----|----------|-----|-------|
| SQ SPK, 2FT W OF W CURB LINE PRODUCED, OF KENTWOOD AVE, 50FT N OF CTR LINE RIGGS PL, IN W END 20FT CB                                                                                                                                                                                                                                                            | 120.340  | 75  | 120.277  | 74P | 120.261  | 70R | 120.247  | 70  |          |     | 17-1  |
|                                                                                                                                                                                                                                                                                                                                                                  | (36.680) |     | (36.660) |     | (36.656) |     | (36.651) |     |          |     |       |
| WIRE SPK IN E END OF CB, N SIDE OF N.O.S. SERVICE ROAD, ABOUT 800FT WLY OF LINCOLN BLVD                                                                                                                                                                                                                                                                          | 52.234   | 85  | 52.159   | 80  | 52.344   | 75  | 52.270   | 74P | 52.264   | 70R | 17-11 |
|                                                                                                                                                                                                                                                                                                                                                                  | (15.921) |     | (15.898) |     | (15.954) |     | (15.932) |     | (15.930) |     |       |
| SSM ON C/L TANG. N.O.S. 0.32MI W OF LINCOLN BLVD 4FT N OF N FLOW LINE OF SERVICE RD & 53.3FT W OF 4IN PIPE GATE POST STA 182 PLUS 09.54                                                                                                                                                                                                                          | 51.693   | 80  | 51.876   | 75  | 51.809   | 74P | 51.800   | 70R | 51.827   | 70  | 17-11 |
|                                                                                                                                                                                                                                                                                                                                                                  | (15.756) |     | (15.812) |     | (15.791) |     | (15.789) |     | (15.797) |     |       |
| SPK IN E END CB ON N'LY SIDE NOS SERVICE ROAD 0.34MI W/O LINCOLN BLVD, 182 PLUS 70                                                                                                                                                                                                                                                                               | 52.195   | 85  |          |     |          |     |          |     |          |     | 17-18 |
|                                                                                                                                                                                                                                                                                                                                                                  | (15.909) |     |          |     |          |     |          |     |          |     |       |
| SPK E END OF CB N SIDE OF SERVICE RD, 0.58MI W OF LINCOLN BLVD                                                                                                                                                                                                                                                                                                   | 52.956   | 85  | 52.877   | 80  | 53.057   | 75  | 52.994   | 74P | 52.974   | 70R | 17-18 |
|                                                                                                                                                                                                                                                                                                                                                                  | (16.141) |     | (16.117) |     | (16.172) |     | (16.153) |     | (16.146) |     |       |
| SPK IN E END CB ON N'LY SIDE NOS SERVICE ROAD 0.78MI W/O LINCOLN BLVD, 160 PLUS 40                                                                                                                                                                                                                                                                               | 51.266   | 85  |          |     |          |     |          |     |          |     | 17-18 |
|                                                                                                                                                                                                                                                                                                                                                                  | (15.626) |     |          |     |          |     |          |     |          |     |       |
| SPK IN E END CB ON N'LY SIDE NOS SERVICE ROAD 0.83MI W/O LINCOLN BLVD, 157 PLUS 00                                                                                                                                                                                                                                                                               | 51.703   | 85  |          |     |          |     |          |     |          |     | 17-18 |
|                                                                                                                                                                                                                                                                                                                                                                  | (15.759) |     |          |     |          |     |          |     |          |     |       |
| CHISEL CROSS WLY SIDE INNER RIM N.O.S. MH, NEAR C/L N.O.S. AT APPROX STA 159 PLUS 25, AT CTR OF R&O SERVICE RD, ABOUT 1000FT ELY OF INTER OF CABORA DR & FALMOUTH AVE, ABOUT 600FT WLY OF 8FT GAS CO CHAIN LINK FENCE ACROSS N.O.S. SERVICE ROAD                                                                                                                 | 51.503   | 80  | 51.676   | 75  | 51.638   | 74P | 51.582   | 70R | 51.607   | 70  | 17-18 |
|                                                                                                                                                                                                                                                                                                                                                                  | (15.698) |     | (15.751) |     | (15.739) |     | (15.722) |     | (15.730) |     |       |
| SPK 1FT W/O W CURB SINALOA RD, 26FT S/O C/L PROD CABORA DRIVE, FRONT OF ELECTROLIER                                                                                                                                                                                                                                                                              | 56.138   | 85  |          |     |          |     |          |     |          |     | 17-1  |
|                                                                                                                                                                                                                                                                                                                                                                  | (17.111) |     |          |     |          |     |          |     |          |     |       |
| COPPER WIRE IN D.H., IN NLY RIM OF N.O.S. MH, ON APPROX C/L N.O.S. ABOUT STA 142 PLUS 00, 9FT WLY OF SLY CURB LINE PROD OF CABORA DR, 15FT WLY OF WLY CURB LINE OF SINALOA RD                                                                                                                                                                                    | 16.204   | 80  | 16.365   | 75  | 16.284   | 74S | 16.283   | 74P | 16.289   | 70R | 17-1  |
|                                                                                                                                                                                                                                                                                                                                                                  | (4.939)  |     | (4.988)  |     | (4.963)  |     | (4.963)  |     | (4.965)  |     |       |
| 2.5IN BRONZE DISC STAMPED *VEN L.A. CITY SURVEY, N.C.O.S. 32 PLUS 27 00, 1961*, ON C/L N.C.O.S., IN S SIDE OF 5FT DIAMETER CONC MH STRUCTURE, 1250FT N OF IMPERIAL HWY ALONG DIRT RD PASSING E OF CALIF. SAND CO. BLDG, 50FT W OF SAID RD, 215FT E OF P POLE #883845E, THE MOST ELY OF THE SIXTH SET OF POLES COUNTED WLY FROM THE CALIFORNIA SAND COMPANY PLANT | 74.495   | 74P | 74.529   | 70  |          |     |          |     |          |     | 17-11 |
|                                                                                                                                                                                                                                                                                                                                                                  | (22.706) |     | (22.716) |     |          |     |          |     |          |     |       |
| ** ONE 1976 **                                                                                                                                                                                                                                                                                                                                                   |          |     |          |     |          |     |          |     |          |     |       |

(METRIC IN PARENTHESES)

P 91

CABORA &  
SINALOA

NEAR BILLOW VISTA

|     |        |
|-----|--------|
| 70  | 16.289 |
| 74P | 16.283 |
| 74S | 16.284 |
| 75  | 16.365 |
| 80  | 16.204 |

|                                                                                                                                                                                                                                      | ELEV    | YR | ELEV    | YR  | ELEV    | YR | ELEV    | YR  | ELEV    | YR  | BN   |
|--------------------------------------------------------------------------------------------------------------------------------------------------------------------------------------------------------------------------------------|---------|----|---------|-----|---------|----|---------|-----|---------|-----|------|
| CITY OF L.A. SURV PBM *STMPD 17-05781 1973*<br>2FT N OF N CURB LINE JEFFERSON BLVD, 4.8FT E OF<br>BC CURB RETURN E OF GROSVENOR BLVD, W END OF CB                                                                                    | 13.415  | 85 | 13.323  | 80  | 13.514  | 75 | 13.433  | 74S | 13.444  | 74P | 17-0 |
|                                                                                                                                                                                                                                      | (4.089) |    | (4.061) |     | (4.119) |    | (4.094) |     | (4.098) |     |      |
| CITY OF L.A. SURV PBM *STMPD 17-05785 1973*<br>1FT N OF N CURB LINE JEFFERSON BLVD, 8.3FT W OF<br>BC CURB RETURN W OF WESTLAHN AVE, W END OF CB                                                                                      | 14.183  | 85 | 14.111  | 80  | 14.326  | 75 | 14.249  | 74S | 14.265  | 74P | 17-0 |
|                                                                                                                                                                                                                                      | (4.323) |    | (4.301) |     | (4.367) |    | (4.343) |     | (4.348) |     |      |
| STD SUR MON, VEN K-3, ON CENTER LINE<br>JEFFERSON BLVD, 58.5FT W OF CENTER LINE PE<br>RY TRACK, 0.37 MILES W OF CENTINELLA BLVD<br>** GONE 1973 **                                                                                   | 14.425  | 70 | 14.461  | 68P | 14.609  | 63 | 14.689  | 60  | 14.711  | 56  | 17-0 |
|                                                                                                                                                                                                                                      | (4.397) |    | (4.408) |     | (4.453) |    | (4.477) |     | (4.484) |     |      |
| CITY OF L.A. SURV PBM *STMPD 17-05800 1973*<br>3.9 FT N OF N CURB LINE JEFFERSON BLVD, 20FT E OF<br>E END OF CONCRETE APRON FOR ELY DRIVEWAY TO COLLINS<br>FOODS INTERNATIONAL AT #12731, IN NW CORNER OF CB                         | 13.727  | 85 | 13.648  | 80  | 13.826  | 75 | 13.747  | 74S | 13.769  | 74P | 17-0 |
|                                                                                                                                                                                                                                      | (4.184) |    | (4.160) |     | (4.214) |    | (4.190) |     | (4.197) |     |      |
| CUT SPK IN CULVERT HEADWALL, 1FT E/O W END, 23FT S<br>OF JEFFERSON BLVD, 165FT W/O C/L INTER P.E.RY &<br>JEFFERSON BLVD, W/O CENTINELLA BLVD<br>** GONE 1972 **                                                                      | 14.048  | 70 | 14.085  | 68P | 14.232  | 63 | 14.315  | 60  | 14.337  | 56  | 17-0 |
|                                                                                                                                                                                                                                      | (4.282) |    | (4.293) |     | (4.338) |    | (4.363) |     | (4.370) |     |      |
| CITY OF L.A. SURV PBM *STMPD 17-05820 1973*<br>2FT N OF N CURB LINE JEFFERSON BLVD, 5FT E OF<br>BC CURB RETURN E OF MC CONNELL AVE, W END CB                                                                                         | 12.385  | 85 | 12.310  | 80  | 12.506  | 75 | 12.423  | 74S | 12.453  | 74P | 17-0 |
|                                                                                                                                                                                                                                      | (3.775) |    | (3.752) |     | (3.812) |    | (3.787) |     | (3.796) |     |      |
| CITY OF L.A. SURV PBM *STMPD 17-05826 1973*<br>2.8FT S OF S CURB LINE JEFFERSON BLVD, 27.3FT E OF<br>E CURB LINE PRODUCED, OF BEETHOVEN ST, IN NE CORNER<br>OF CONCRETE FOOTING FOR TRAFFIC SIGNAL CONTROL BOX                       | 13.963  | 85 | 13.967  | 80  | 14.154  | 75 | 14.072  | 74S | 14.096  | 74P | 17-0 |
|                                                                                                                                                                                                                                      | (4.256) |    | (4.257) |     | (4.314) |    | (4.289) |     | (4.296) |     |      |
| CUT SPK IN CULVERT HEADWALL, 1FT E OF W END, 25.5FT<br>S OF CTR LINE JEFFERSON BLVD, ABOUT 400FT W OF<br>BEETHOVEN ST, 30FT E OF DRIVEWAY TO POWER STATION,<br>0.22MI W OF MCCONNELL AVE, 0.5MI E OF LINCOLN BLVD<br>** GONE 1972 ** | 9.180   | 70 | 9.217   | 68P | 9.393   | 63 | 9.467   | 60  | 9.508   | 56  | 17-0 |
|                                                                                                                                                                                                                                      | (2.798) |    | (2.809) |     | (2.863) |    | (2.886) |     | (2.898) |     |      |
| CITY OF L.A. SURV PBM *STMPD 17-05845 1973*<br>4FT W OF W CURB LINE OF ALLA RD, 10.2FT N OF<br>BC CURB RETURN N OF JEFFERSON BLVD, N END CB                                                                                          | 12.287  | 85 | 12.208  | 80  | 12.388  | 75 | 12.290  | 74S | 12.317  | 74P | 17-0 |
|                                                                                                                                                                                                                                      | (3.745) |    | (3.721) |     | (3.776) |    | (3.746) |     | (3.754) |     |      |

(METRIC IN PARENTHESES)



|                                                                                                                                           | ELEV     | YR | ELEV     | YR  | ELEV     | YR  | ELEV     | YR  | ELL.     | YR  | B      |
|-------------------------------------------------------------------------------------------------------------------------------------------|----------|----|----------|-----|----------|-----|----------|-----|----------|-----|--------|
| STD SUR MON, VEN I-4B, ON CENTER LINE JEFFERSON BLVD, 1.05MI WESTERLY FROM CENTINELA AVENUE, 68FT EAST OF PP #310227M.<br>** GONE 1973 ** | 7.898    | 70 | 7.935    | 68P | 8.081    | 63  | 8.146    | 60  | 8.191    | 56  | 17-    |
|                                                                                                                                           | (2.407)  |    | (2.419)  |     | (2.463)  |     | (2.483)  |     | (2.497)  |     |        |
| CITY OF L.A. SURV PBM #STMPD 17-05865 1973*<br>2FT E OF E CURB LINE OF BAY ST, 10.8FT N OF BC CURB RETURN N OF JEFFERSON BLVD, N END CB   | 12.746   | 85 | 12.694   | 80  | 12.883   | 75  | 12.783   | 74S | 12.823   | 74P | 17-0   |
|                                                                                                                                           | (3.885)  |    | (3.869)  |     | (3.927)  |     | (3.896)  |     | (3.908)  |     |        |
| WIRE SPIKE 25.5FT S OF JEFFERSON BLVD 234.5FT E OF CENTER LINE LINCOLN BLVD, 0.5FT E OF W END OF CULVERT HEADHALL<br>** GONE 1972 **      | 7.930    | 70 | 7.968    | 68P | 8.086    | 63  | 8.151    | 60  | 8.203    | 56  | 17-0.  |
|                                                                                                                                           | (2.417)  |    | (2.429)  |     | (2.465)  |     | (2.484)  |     | (2.500)  |     |        |
| WIRE SPIKE IN W CURB CENTINELA AVE 0.8FT N OF BC CURB RET N OF MATTESON AVE<br>** GONE 1963 **                                            | 56.736   | 60 | 56.768   | 56  | 56.820   | 55  | 56.848   | 53  |          |     | 17-0!  |
|                                                                                                                                           | (17.293) |    | (17.303) |     | (17.319) |     | (17.327) |     |          |     |        |
| WIRE SPIKE IN W CURB CENTINELA AVE 1.2FT S OF BC CURB RET S OF MATTESON AVE                                                               | 55.905   | 85 | 55.823   | 80  | 56.036   | 75  | 55.974   | 70  | 56.021   | 68P | 17-05  |
|                                                                                                                                           | (17.040) |    | (17.015) |     | (17.080) |     | (17.061) |     | (17.075) |     |        |
| WIRE SPIKE IN W CURB CENTINELA AVE .5FT N OF BC CURB RETURN NORTH OF BARBARA AVENUE.                                                      | 54.685   | 80 | 54.889   | 75  | 54.829   | 70  | 54.876   | 68P | 54.987   | 63  | 17-05  |
|                                                                                                                                           | (16.668) |    | (16.730) |     | (16.712) |     | (16.726) |     | (16.760) |     |        |
| WIRE SPK IN W CURB CENTINELA AVE, 0.5FT N/O BC RET N/O CASWELL AVE                                                                        | 52.664   | 85 | 52.592   | 80  | 52.796   | 75  | 52.738   | 70  | 52.785   | 68P | 17-05  |
|                                                                                                                                           | (16.052) |    | (16.030) |     | (16.092) |     | (16.075) |     | (16.089) |     |        |
| WIRE SPIKE IN W CURB CENTINELA AVE 0.7FT N OF BC CURB RET N OF MITCHELL AVE                                                               | 50.650   | 80 | 50.844   | 75  | 50.817   | 70  | 50.864   | 68P | 50.967   | 63  | 17-05  |
|                                                                                                                                           | (15.438) |    | (15.497) |     | (15.489) |     | (15.503) |     | (15.535) |     |        |
| STD SUR MON, SAN I-12B, ON CENTER LINE INTER OF CENTINELA AVENUE AND MITCHELL AVENUE, FROM THE WEST<br>** GONE 1960 **                    | 50.717   | 56 | 50.764   | 55  |          |     |          |     |          |     | 17-05! |
|                                                                                                                                           | (15.459) |    | (15.473) |     |          |     |          |     |          |     |        |
| WIRE SPIKE IN W CURB CENTINELA AVE 0.8FT S OF BC CURB RETURN NORTH OF WASHINGTON PLACE.                                                   | 49.109   | 75 | 49.062   | 70  | 49.108   | 68P | 49.269   | 60  | 49.318   | 56  | 17-05! |
|                                                                                                                                           | (14.968) |    | (14.954) |     | (14.968) |     | (15.017) |     | (15.032) |     |        |
| STD SUR MON, VEN I-1A, CENTER LINE CENTINELA AVENUE 13.2FT SOUTH OF CENTER LINE WASHINGTON PLACE. EAST<br>* RESET 1969 *                  | 47.796   | 56 | 47.846   | 55  | 47.886   | 53  |          |     |          |     | 17-06! |
|                                                                                                                                           | (14.568) |    | (14.583) |     | (14.596) |     |          |     |          |     |        |
| WIRE SPK IN S CURB WASHINGTON PL, 21.5FT E OF BC CURB RET E OF CENTINELA AVE, E END CB                                                    | 48.468   | 85 | 48.386   | 80  | 48.585   | 75  | 48.530   | 70  | 48.576   | 68P | 17-060 |
|                                                                                                                                           | (14.773) |    | (14.748) |     | (14.809) |     | (14.792) |     | (14.806) |     |        |

INTER-DEPARTMENTAL CORRESPONDENCE

February 20, 2001

To: Vitaly B. Troyan, P.E.  
City Engineer

From: David T. Hsu, Chief of Grading Section  
Department of Building and Safety

Subject: REGIONAL GROUND SUBSIDENCE AT PLAYA VISTA, PLAYA DEL REY  
AND THE MARINA PENINSULA, AND RELATED GAS MIGRATION  
PROBLEMS, dated February 15, 2001, prepared by Bernard Endres, Ph.D.

REFERENCE: Inter-Departmental Correspondence, dated October 24, 2000, City Engineer

The Department of Building and Safety has received a report concerning subsidence for the Playa Vista area that may affect your conclusions regarding this issue. Please evaluate the attached data with regard to the conclusions of the above referenced letter and inform me of any revisions to your conclusions. Please be aware that an appeal concerning the issue of subsidence at the Playa Vista development has been filed with the Board of Building and Safety Commissioners. Therefore, time is very important with regard to your conclusions.

If you have any questions regarding this information please contact myself at (213)977-6317 or Dana Prevost at (213)97706326.

Attachments: 1) Report dated February 15, 2001, by Bernard Endres Ph.D.

G:/grdocs/grletters/playavista/subsidenceendres

NO RESPONSE

City of Los Angeles  
INTER-DEPARTMENTAL CORRESPONDENCE

4



February 20, 2001

To: Vitaly B. Troyan, P.E.  
City Engineer

From: David T. Hsu, Chief of Grading Section  
Department of Building and Safety

Subject: REGIONAL GROUND SUBSIDENCE AT PLAYA VISTA, PLAYA DEL REY  
AND THE MARINA PENINSULA, AND RELATED GAS MIGRATION  
PROBLEMS, dated February 15, 2001, prepared by Bernard Endres, Ph.D.

REFERENCE: Inter-Departmental Correspondence, dated October 24, 2000, City Engineer

The Department of Building and Safety has received a report concerning subsidence for the Playa Vista area that may affect your conclusions regarding this issue. Please evaluate the attached data with regard to the conclusions of the above referenced letter and inform me of any revisions to your conclusions. Please be aware that an appeal concerning the issue of subsidence at the Playa Vista development has been filed with the Board of Building and Safety Commissioners. Therefore, time is very important with regard to your conclusions.

If you have any questions regarding this information please contact myself at (213)977-6317 or Dana Prevost at (213)97706326.

Attachments: 1) Report dated February 15, 2001, by Bernard Endres Ph.D.

G:/grdocs/grletters/playavista/subsidenceendres

NO RESPONSE

LOS ANGELES  
INTER-DEPARTMENTAL CORRESPONDENCE

Date: May 3, 2000

To: Dana Prevost, David Hsu, Grading Engineering Section  
Los Angeles Dept. of Building and Safety

→ From: Art Kurimoto, Survey Supervisor, Survey Division, Bureau of Engineering  
Los Angeles Dept. of Public Works

→ Subject: **Playa Vista Project Grading Report and Improper Misquotes Regarding Area Subsidence**

It has come to my attention that a report inquiring about methane gas migration leading to ground subsidence in the area of the Playa Vista Development Project has used statements made by me ( in a five minute telephone conversation on May 19, 1999 ) as expert testimony refuting any such ground subsidence during the period of 1975 to 1985. I am alarmed at this, as any statements made by me have been taken out of context.

In my conversation with Mr Steve Kolthoff of Group Delta Consultants, I explained that the City of Los Angeles conducted precise leveling operations citywide on a five year cycle. I explained that I knew of no subsidence studies in the area. However, there are streets such as Jefferson Blvd, Lincoln Blvd and Culver Blvd that have a history of benchmarks that have been remeasured every five years on average since the 1950's as part of a vertical control maintenance program.

In 1985, this citywide leveling program was ended due to lack of funding. This had nothing to do with any subsidence study. I stated that a simple comparison of existing benchmarks along these streets over the years would show vertical ground movement variations in five year increments. I also stated that these records were public information and could be purchased at our Engineering counter for a small reprographics fee.

I stated that it was my opinion that there was little or no appreciable ground movement over these recorded benchmarks ( which are on the roadway, not in the marshland ) and any real comparison would have to be done by Mr. Kolthoff himself. ←

→ I do not have any expertise in any matter involving methane gas migration. I do not have any information on any ground subsidence in the project area of the Playa Vista Development. I refute any reference to me as having given expert testimony on any matter regarding ground subsidence at all. Clearly, I have been misquoted during my short conversation with Mr. Kolthoff, and had I known that I would be used as an advisor in a published report, I would have ended the conversation immediately.

Should you have any further questions in this regard, I am available at my office each day.

Phone 310-575-8493  
Fax 310-575-8866  
E-mail [wiasurvey@eng.ci.la.ca.us](mailto:wiasurvey@eng.ci.la.ca.us)



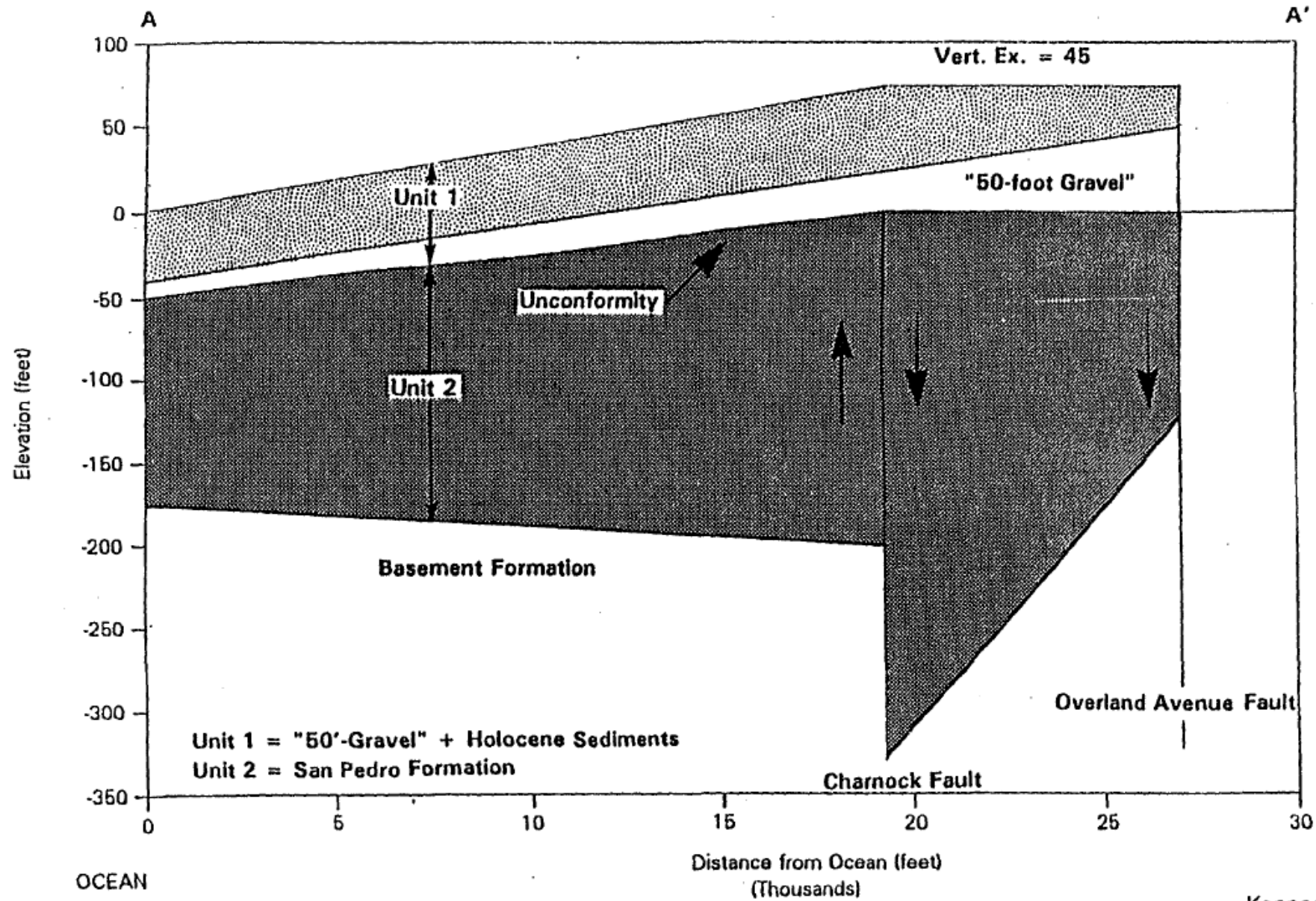

Kennedy/Jenks Consultants

Santa Monica Groundwater Management Plan

Idealized Geologic Cross-Section A-A'

K/J 910012  
June 1992

Figure 2.3

CA. Public Utilities Safety  
Report

**Complaint Case Facts and Findings  
(Playa Del Rey Storage Field)**

**By**

**Consumer Protection and Safety Division**

**August 20, 2002**

**Revised on November 18, 2004**

## **Table of Contents**

|                                            | <b>Page</b>              |
|--------------------------------------------|--------------------------|
| <b>Introduction &amp; Background</b>       | <b>1</b>                 |
| <b>Discussions of Facts &amp; Findings</b> | <b>2-6</b>               |
| <b>Recommendations</b>                     | <b>7</b>                 |
| <b>Appendices</b>                          | <b>A, - D, F &amp; M</b> |

## **I Introduction**

This report presents some of the data that Consumer Protection and Safety Division (CPSD) has gathered from the investigation of the Complaint Case (C.00-05-010) proceedings. On May 11, 2000, three residents of Playa Del Rey area filed similar complaints against SoCalGas, C.00-05-010, C.00-05-011 and C.00-05-012, respectively. In addition, Grassroots Coalition and several other residents of Playa del Rey (PDR) and Marina del Rey joined the complaints. Although the complaints were filed separately and individually, they shared a common concern that SoCalGas is operating its Playa Del Rey gas storage facility unsafely, in a manner hazardous to the health and safety of nearby homeowners. Specifically, the complainants alleged the storage reservoir was leaking, resulting in dangerous toxic pollution from venting and leaking gas, atmospheric contamination, noxious odors, and a leaking abandoned well. Each complainant asked the CPUC to conduct an investigation of the SoCalGas Storage facilities in Playa Del Rey.

SoCalGas filed a motion to dismiss these cases or consolidate the cases. Although the Commission denied the motion to dismiss the cases, but the motion to consolidate was granted and the three complaints were consolidated under Rule 55 of the Commission's Rules of Practice and Procedure. These three cases are now treated as one case under C.00-05-010.

CPSD investigations focused on all the allegations. During the course of these investigations, CPSD conducted laboratory analysis (Isotopic Analysis) of field samples from leaking abandoned well. CPSD also requested and reviewed large volume of data from SoCalGas and Grassroots Coalition. After review of all available data provided to CPSD, the findings were used to determine the merit of the allegations and consequently resolved some of the allegations. The remaining unresolved allegations have been classified into two issues: **(1) Any evidence of PDR storage gas and/ or Thermogenic gas within SoCalGas mineral rights migrating to the surface, (2) Any evidence that the PDR Gas Treatment and/ or PDR Gas Storage facilities are contributing to local**



residents' exposure to carcinogenic toxins. This report focuses on some of the data CPSD has collected, implications of our findings to date, and recommendations for resolving the two remaining allegations.

## II. Discussions of Facts and Findings

One must remember that the following facts and findings do not definitively explain or answer the allegations. However, this information, individually or cumulatively, indicate that there might be potential problems that warrant further investigation. The type of investigation or study scope must consider the available data, along with how to integrate that data into a full reservoir study and a Health Risk Assessment (HRA) that provides definitive results that lead to resolution of the two outstanding allegations. It is important to note facts and findings presented below do not indicate any wrong doing on the part of SoCalGas. Instead, they simply reflect the existence of potential hazards compounded by lack of definitive test results or data gaps. The following facts are discussed below:

- (a) Evidence of three types of natural gas in PDR
- (b) 133 PPM Helium in a natural gas sample from a bar hole near Big Ben well
- (c) 22 PPM Helium from a shallow probe by John Sepich & Assoc.,
- (d) Greater than 800 PPM Helium from groundwater samples
- (e) ETI report indicated Thermogenic gas components detected in shallow subsurface geologic units and H<sub>2</sub>S detected in soil gas samples
- (f) Previous reservoir inventory analysis
- (g) 50,000 PPM gas detected at Troxel Well and known migration loss to well
- (h) Potential problems with validity of some SoCalGas data.

### A. Three types of natural gas in PDR

There is evidence of surface detection of three types of natural gas in PDR namely: Biogenic gas, Native PDR Thermogenic gas and Storage Reservoir

Thermogenic gas. Biogenic gas is commonly known as Swamp gas. Its chemical and physical characteristics are mostly Methane gas, formed by bacteria action in shallow surface. It has *no* Helium, Ethane, Butane or other heavier hydrocarbon. Biogenic gas is non jurisdictional. In contrast, Native PDR Thermogenic gas (native PDR gas) and Storage Reservoir Thermogenic gas (Storage gas) are formed by decomposition of prehistoric fossils under high temperature and pressure in deep and intermediate geological zones. Thermogenic gases have, Methane, Ethane, Helium and other hydrocarbons. Both native thermogenic and storage reservoir thermogenic gases have some identical physical and chemical characteristics contain varying amounts of Helium, Ethane, Methane and other hydrocarbons. Unfortunately, these identical characteristics make it difficult to differentiate Native PDR gas from Storage Reservoir gas. However, experts like Dr. Archart (Department of Geological Sciences, University of Nevada) have discovered some subtle differences such as the difference in Helium content and the age of the Helium. There are evidence from various gas sample tests and isotopic analysis that show each of these three gases emanating to the ground surface at various locations at one time or another. The presence of Ethane, Methane, Helium and other hydrocarbons are one of the key considerations in determining if a sample is Biogenic or Thermogenic. Once it is determined that a sample is Thermogenic, then the Helium and the concentration present in that sample determines if it's Native PDR gas (1-15 PPM Helium) or Storage Reservoir gas (15-450 PPM Helium). However, commingling of these gases, alteration of physical and chemical properties by some external factors, and filtration of some gas constituents (possibly by groundwater or aquifer) obscure the minor differences and complicates the chemical speciation. *Please see Appendix # A*

**B. 133 PPM Helium from bar hole samples near Big Ben Well**

SoCalGas internal office memorandum, dated November 20, 1991 revealed that gas samples collected from bar-holes around Big Ben Well contained 30,000 PPM to 620,000 PPM natural gas and these samples contained 133 PPM to 188 PPM

Helium. A close examination of the memo revealed that three samples were collected on 1/11/91, at bar-holes # 12, 13 & 14. Isotopic analysis of these samples indicated with high probability the signature of Storage Reservoir gas (meaning that the gas migrated from Storage Reservoir). In addition, the memo did not indicate any more sampling at these bar-holes or subsequent remedial action. On 8/23/91 and subsequent dates, samples were collected from bar-hole H instead of bar-holes 12, 13 & 14. The isotopic analyses of the new samples did not reveal the storage gas signature and subsequent discussion on the memo ignored the initial sample data, its significance and if there was any remedial action. *Please see Appendix # B*

**C. 22 PPM Helium from a shallow probe sample by John Sepich and Associate.**

Isotech Laboratory performed an isotopic analysis of a gas sample submitted by Sepich & Associates on 3/25/99. Sepich and Associates was working for Playa Vista developers (developers of residential and business properties around the PDR.Storage field. The isotopic analysis report indicates the gas sample was collected from Playa Vista Project Area-D. The analysis report also revealed presence of Ethane and 22 PPM Helium in the gas sample. The significance of this isotopic analysis report is the presence Storage Reservoir gas or Native PDR gas signature and the location where the gas sample was collected (Area - D of Playa Vista Project). My opinion is that the probability of Storage Reservoir gas sample from PDR area containing Ethane and 22 PPM Helium is greater than 50 percent (>50%). Furthermore, the location where the sample was collected should be of major concern. *Please see Appendix # C*

**D. 100 PPM-1000 PPM Helium from groundwater samples collected and analyzed by Exploration Technologies, Inc (ETI)**

City of Los Angeles Building and Safety Department retained ETI to conduct test, analyze and provide advice on Playa Vista project. Groundwater samples were collected in 2000 from Playa Vista Project Area, and dissolved

gases were extracted and analyzed by ETI in addition to other scientific sampling and testing. Several groundwater samples revealed presence of high Helium concentrations and methane dissolved in the groundwater. The origin of this Helium in the groundwater is not clear. However, some people have postulated that the groundwater absorbs or strips the Helium from the Storage Reservoir gas or Native PDR gas as it migrates through the aquifer to the ground surface. Hence, Thermogenic gas is detected in soil-gas without Helium. Although, this postulation seems plausible, I have not seen any scientific paper on this absorption theory and the kinetics. *Please see Appendix # D*

**E. Dr Victor Jones of ETI detected Thermogenic gas components at the surface and detected H<sub>2</sub>S in soil gas during his investigation in 2000.**

ETI conducted an extensive soil gas investigation in Playa Vista area for the City of Los Angeles in 2000. The isotopic analysis report of the samples collected revealed presence of Methane, Ethane, Helium, H<sub>2</sub>S, Toluene and other volatile organic compounds (voc). The presence of numerous Thermogenic gas components in the shallow soil gas samples analyzed indicates a deeper source for this gas.

**F. Previous Reservoir Inventory Verification Analysis by SCG indicated gas migration loss (8/22/80)**

A Reservoir Inventory Verification Analysis conducted by Theodoros Georgakopoulos on August 22, 1980, for SoCalGas indicated gas migration loss. The migration pathways to the Townsite area (separate geologic zone) is unknown. The report estimated storage reservoir gas loss between January 1961 and December 1979 to be 0.10 B.c.f. Subsequent reports estimated the gas loss to have decreased. *Please see Appendix # F*

### **G. Presence of Methane gas around Troxel Well.**

As part of Energy Division (ED) initial preliminary investigation, ED retained MHA, who subcontracted Giroux & Associates to conduct site investigations at the Troxel and Lor Mar well site locations in 2001. These recent studies found very high methane concentrations (greater than 50,000 ppm) at the Troxel site and low methane concentrations (1 to 6 ppm) at the Lor Mar site.

Although high methane levels at Troxel dissipated over time, low methane levels persisted through the end of the 32 days study period. This indicates a possible source of methane at this location. Methane concentrations also fluctuated during the study period, indicating that external factors (atmospheric pressure, tidal influences, gas storage reservoir operations) may be affecting data measurements. However, a soil gas survey study requested by the Commission and conducted by SoCalGas' consultant, TRC concluded that there were no measurable concentrations of volatile or combustible compounds encountered in the soil gas. Also, the study detected presence of Hydrogen Sulfide and the source was unknown. But recent sampling by Energy Division's CEQA team reported measurable concentrations volatile hydrocarbons.

### **H. Validity of SoCalGas Data.**

Data collected by SoCalGas may be flawed. Procedures used by SoCalGas to collect gas samples at the Troxel did not follow standard gas collection and sample handling procedures established by Federal Environmental Protection Agency and other trade associations. A plastic sheet was used to accumulate enough gas to collect samples for analysis. Samples were collected in plastic bottles. Since plastic is permeable to many gases, and may also absorb some hydrocarbon based gases, test results would not fully characterize gas emitted from the well.

Although bar hole testing is acceptable for Department of Oil Gas & Geothermal Resources leak detection requirement, it does not follow standard procedures established

for soil gas investigations. Soil is disturbed and compacted when the bar is driven into the ground. This could interfere with movement of some soil gas. Therefore, low levels of methane may not be detected and concentrations reported may not be valid.

### **III. Recommendations**

A review of the aforementioned facts and findings suggest the existence of a potential safety hazard. Since the available geological data does not definitively support or disprove the existence of safety hazard in and around the storage reservoir, further investigation and study is needed. It is important and recommended that CPSD conduct (1) comprehensive reservoir study and (2) Health Risk Assessment (HRA) (HRA that is not limited to 'for sale lots' and integrate some of the data gathered from the CEQA study). The basis for this recommendation are in response to allegations of hazards to public health and Safety, potential ratepayer liability, lack of definitive results from available data and mandate from General Order 58-A, section 22. We recommend a reservoir study that will include but not limited to:

- 1) Construction of a 3-dimensional geologic computer model (Earth Vision or equivalent) using existing data (wells records, soil gas investigations, geo-technical borings, geophysical data, environmental borings, site contamination data, groundwater data, etc) to fully integrate and visually display geologic data (strata and discontinuities) and other subsurface information (gas and groundwater locations) at the storage field.
- 2) Drill a minimum of three shallow well observation wells to describe the stratigraphic conditions (visual and geophysical logging) in geologic deposits above 1000 feet elevation in order to define potential gas storage zones and migration pathways, and to collect gas samples from depths below biogenic sources.
- 3) Collect and analyze (isotopic and chemical analysis) the gas in geologic deposits from these wells, focusing on depths below

minus 500 feet elevation (below sea level), in order to determine the origin and genesis of the gas.

- 4) Integrate the results from items 1, 2 and 3 above to develop a logical, defensible subsurface model that explains the surface and subsurface gas detections and the potential pathways for gas to reach the surface environment.
- 5) Retain an expert to perform Helium Ratio Analysis.

CONTINUOUS COALITION  
SAGE COUNCIL

# SOUTHERN CALIFORNIA GAS COMPANY'S APPLICATION TO VALUE AND SELL SURPLUS PROPERTY AT PLAYA DEL REY AND MARINA DEL REY

*Initial Study*  
*CPUC Application No. 99-05-029*

*September 2003*

*Prepared for*  
*California Public Utilities Commission*



**ESA** Environmental  
Science  
Associates



migration, by either acting as barriers to lateral movement or pathways for vertical migration. Gas movement rates associated with minor faulting would not be significant compared to leaking wells.

The presence of shallow high-pressure gas zones encountered in the Playa Vista area indicates confinement of upward hydrocarbon migration from these intervals. At these locations, shale intervals within the Pico and Repetto Formation form effective cap rock or seals. If natural upward migration pathways were present, such as open fracture systems, gas in these shallow zones would exhibit a normal pressure gradient. High pressure was not released until these zones were penetrated during well drilling operations.

### Leaking Wells

Several factors contribute to possible gas migrations through abandoned and active wells such as original drilling, development and completion, operations and redevelopment, and abandonment. Many wells and dry holes were drilled during the exploration and early field development period. Dry or non-commercial wells were abandoned. Common practice by some operators in the 1920s through 1940s was to abandon wells and dry holes by filling them with construction debris or other items, such as telephone poles or railroad ties, prior to covering the surface with soil. These improperly abandoned wells have been unearthed during grading operations for construction sites located over old oil field in several areas of the Los Angeles Basin. Many of these wells and dry holes may not have been plugged to modern standards. Current abandonment requirements have developed since the 1950s to the more stringent standards today. Old dry holes and noncommercial wells have a high potential to provide migrations pathways.

Early in the history of oil and gas development in California and the United States, noncommercial or dry holes were drilled and abandoned without proper documentation and reporting, and some of these abandoned dry holes and wells may not have been recorded by the original drillers or DOGGR. Absence of unknown abandoned holes cannot be determined with certainty. Should they exist, they could serve as migration pathways.

Well construction, redevelopment, and abandonment deficiencies can contribute to gas migration problems. If cement bonds between the casing and surrounding natural formation do not form adequate storage seals, pressurized leakage is possible. Leakage through the annular space between casing and formation can occur under the following circumstances: lack of proper seals, inadequate seal or poor cement bonds with bore walls, channels within cement, deterioration of annular seals over time, and fracturing or cavitation of enclosing walls.

When present, shallow high-pressure gas zones can create problems for cement annular seals. During the well completion process, cement slurry is pumped into the annular space between the hole drilled (rock face) and casing to form a seal. Gas from shallow high-pressure zones can enter cement within the annular space during this process. Gas bubbles within the slurry weakens the cement and can compromise seals around these zones. In turn, poor seals could allow fluid migrations and enhance corrosion of both casing and cement in these areas. If large volumes of gas enter the annular space, vertical channels within the cement seal can also form. Marlow (1989) discusses the mechanisms contributing to compromised integrity of annular cement seals associated with gas zones.

- Based on the data provided, three leaking wells were discovered following detection of soil gas seepage. During routine field monitoring, near surface gas was identified around three wells: Well No. 12-1 (1974), Well No. 24-2 (1975) and Big Ben No. 1 (1991). Leaks in Wells No. 12-1 and 24-2 were repaired, while Big Ben No. 1 was plugged and abandoned in 1991.
- Of the ten wells with documented leaks, three of them are included in the subject project: Well No. 29-1 (1959), Lor Mar No.1 (1981) and Joyce No.1 (1987). Casing leaks in each respective well were repaired. These three wells are on parcels (lots) subject to sale following approval of the proposed project. The Lor Mar No. 1, Joyce No. 1 and Well No. 29-1 were plugged and abandoned in 1992, 1993 and 1994, respectively.
- The ten wells are located between 1/2 mile and 1 mile south to southwest of the Universal City Syndicate Inc. Vidor No. 1. The Vidor No. 1, an old abandoned well, experienced a "blow-out" when shallow gas was encountered during drilling at depths from 1,140 to 1,150 feet. Multiple shallow gas zones were penetrated by this well. At least 4 other wells drilled in the Vidor No. 1 vicinity also penetrated various shallow gas zones at depths ranging from 510 to 3,434 feet.

Leaks in several of the ten wells listed occurred at similar depths to where shallow gas was encountered in old wells experiencing "blow-outs". These old wells were located immediately east and northeast of the subject project. Insufficient data was provided to correlate documented leaks with shallow gas zones.

### Gas Responsibility and Rights

SCG owns most, if not all mineral rights in the PDR field and storage zone. As such, SCG is responsible for any gas leaks originating the PDRGSF area of influence and from thermogenic sources. Due to the nature of recent alluvial deposits, the generation of natural biogenic gas at the project site is likely. Biogenic gas in the area is probably related to decomposition of organic material deposited within a lagoon environment. In addition, some biogenic gas could also result from alteration of other hydrocarbons, including thermogenic gas, crude oil, or spilled materials. SCG is not responsible for occurrences of biogenic gas at the project site.

**TABLE F-1  
SUMMARY OF DETECTED GAS LEAK**

| Well Name       | Problem           | Depth (ft bgs) | Year Detected | Well Location                                                               |
|-----------------|-------------------|----------------|---------------|-----------------------------------------------------------------------------|
| Well No. 29-1   | Stage collar leak | 723            | 1959          | Between Falmouth Ave. & Calabar Ave., south of intersection with Cabora Dr. |
| Big Ben No. 1   | Casing leak       | 150            | 1964          | Between 79th St. & Veraqua Dr., northeast Zayenta Dr.                       |
|                 | Surface seepage   |                | 1991          |                                                                             |
| Blackline No. 1 | Casing leak       | 1,064          | 1969          | South of Cabora Dr., west of Veraqua Dr. and Zayenta Dr. intersection       |
|                 | Casing leak       | 1,060          | 1986          |                                                                             |
| SoCal No. 4     | Casing leak       | 3,216          | 1971          | NW of Cabora Dr., about 1,000 ft. NE of intersection with Falmouth Ave. *   |
| SoCal No. 3     | Casing leak       | 3,300          | 1972          | NW of Cabora Dr., about 1,000 ft. NE of intersection with Falmouth Ave. *   |
|                 | Casing leak       | 3,300          | 1975          |                                                                             |
|                 | Casing leak       | 2,109          | 1977          |                                                                             |
| Well No. 12-1   | Surface seepage   | 481            | 1974          | Southeast of 81st St., north of intersection with 83rd St.                  |
|                 | Casing leak       | 210            | 1979          |                                                                             |
| Well No. 24-2   | Surface seepage   | 191            | 1975          | Northwest of 79th St., west of Zayenta Dr.                                  |
| Pomoc No. 1     | Casing leak       | 2,815          | 1975          | West of Zayenta Dr., between 79th St and Cabora Dr.                         |
| Joyce No. 1     | Casing leak       | 750            | 1987          | Northwest of 82nd St., east of Saran Dr.                                    |
| Lor Mar No. 1   | Casing leak       | 720            | 1981          | South of 83rd St., east of Saran Dr.                                        |

\* Surface location of directionally drilled well. Bottom hole locations were not made available.

SOURCE: (DOGGR, various dates)

- Based on the data provided, three leaking wells were discovered following detection of soil gas seepage. During routine field monitoring, near surface gas was identified around three wells: Well No. 12-1 (1974), Well No. 24-2 (1975) and Big Ben No. 1 (1991). Leaks in Wells No. 12-1 and 24-2 were repaired, while Big Ben No. 1 was plugged and abandoned in 1991.
- Of the ten wells with documented leaks, three of them are included in the subject project: Well No. 29-1 (1959), Lor Mar No.1 (1981) and Joyce No.1 (1987). Casing leaks in each respective well were repaired. These three wells are on parcels (lots) subject to sale following approval of the proposed project. The Lor Mar No. 1, Joyce No. 1 and Well No. 29-1 were plugged and abandoned in 1992, 1993 and 1994, respectively.
- The ten wells are located between 1/2 mile and 1 mile south to southwest of the Universal City Syndicate Inc. Vidor No. 1. The Vidor No. 1, an old abandoned well, experienced a "blow-out" when shallow gas was encountered during drilling at depths from 1,140 to 1,150 feet. Multiple shallow gas zones were penetrated by this well. At least 4 other wells drilled in the Vidor No. 1 vicinity also penetrated various shallow gas zones at depths ranging from 510 to 3,434 feet.

Leaks in several of the ten wells listed occurred at similar depths to where shallow gas was encountered in old wells experiencing "blow-outs". These old wells were located immediately east and northeast of the subject project. Insufficient data was provided to correlate documented leaks with shallow gas zones.

### **Gas Responsibility and Rights**

SCG owns most, if not all mineral rights in the PDR field and storage zone. As such, SCG is responsible for any gas leaks originating the PDRGSF area of influence and from thermogenic sources. Due to the nature of recent alluvial deposits, the generation of natural biogenic gas at the project site is likely. Biogenic gas in the area is probably related to decomposition of organic material deposited within a lagoon environment. In addition, some biogenic gas could also result from alteration of other hydrocarbons, including thermogenic gas, crude oil, or spilled materials. SCG is not responsible for occurrences of biogenic gas at the project site.

## APPENDIX F

### HAZARDS AND HAZARDOUS MATERIALS BACKGROUND INFORMATION

#### ENVIRONMENTAL SETTING

As discussed in Section VII, Geology and Soils, the project area overlies a region of oil fields as shown on Figure F-1. In the early twentieth century oil was extracted from this region and in 1942, the Southern California Gas Company (SCG) converted the depleted Playa del Rey oil field into a natural gas storage reservoir; one of five gas storage facilities operated and maintained by SCG in the Los Angeles region, within a 40 mile radius of the project area. These facilities are capable of meeting all current and anticipated SCG future needs for the Los Angeles region. Therefore, the regional value of gas storage has declined in accordance with increasing available supply of storage and available transmission capacity to serve the regional demands.

There are no designated quarry areas either on the project lots or in the vicinity of the project lots.

#### REGULATORY SETTING

The current regulatory framework relevant to hazards and human health encompasses process risk related to the use of hazardous materials and management of risks from hazardous materials that have been released to the environment. With respect to chemical hazards, the use, storage, and disposal of hazardous materials and wastes are regulated through a network of overlapping federal, state, and local laws and regulations. Various government agencies are responsible for implementing these laws and enforcing their requirements.

Federal and state laws require planning to ensure that hazardous materials are properly used, stored, and disposed of, and in the event that such materials are accidentally released, to prevent or to reduce injuries to human health, safety, or the environment. Businesses must store hazardous materials appropriately and train employees to manage them safely. Hazardous waste laws impose cradle-to-grave liability, requiring generators of hazardous wastes to handle them in a manner that protects human health and the environment to the extent possible. Both federal and state laws have established programs to identify hazardous waste sites, to require site remediation, and to recover the costs of site remediation from polluters. The following discussion briefly summarizes regulations that must be complied with regardless of ownership of the generating station.

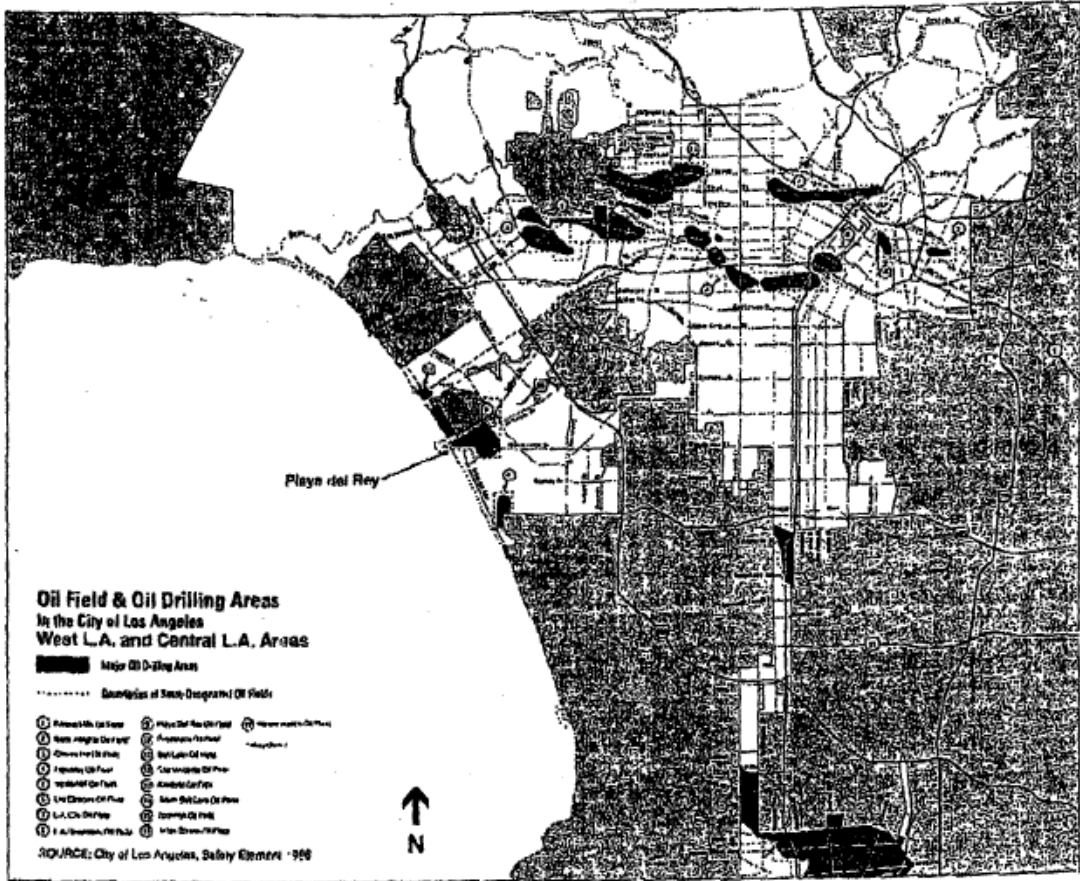

SOURCE: City of Los Angeles, Safety Element 1996

SCG Valuation and Sale of Surplus Property at Playa del Rey and Marine del Rey Project / 2026.19

**Figure F-1**  
Oil Fields in the West and Central Los Angeles Areas

**APPENDIX F****HAZARDS AND HAZARDOUS MATERIALS BACKGROUND INFORMATION****FEDERAL*****COMPREHENSIVE ENVIRONMENTAL RESPONSE, COMPENSATION AND LIABILITY ACT (CERCLA)***

Commonly known as Superfund, this federal law defines reportable quantities for spilled materials and the process for investigation and cleanup of contaminated sites. The Comprehensive Environmental Response, Compensation and Liability Act (CERCLA) also establishes a National Priorities List and outlines a liability and response mechanism for releases of oil and hazardous materials.

***SUPERFUND AMENDMENTS AND REAUTHORIZATION ACT (SARA) OF 1986***

This law establishes public reporting of the use of certain chemicals under Title III, also known as the Emergency Planning and Community Right-to-Know Act. In California, some of the provisions of the Superfund Amendments and Reauthorization Act (SARA) Title III are implemented locally by the city or county health department through the Business Plan and hazardous material inventory requirements.

***CLEAN WATER ACT (CWA)***

The CWA sets up the framework through which permits to discharge waste to surface waters are authorized. The National Pollutant Discharge Elimination System (NPDES) permit typically has conditions specific to the permitted operation and may set limits on acidity (pH), chemical concentrations, oil and grease, dissolved and suspended solids, and temperature of the discharge. The CWA also prohibits the discharge of pollutants to storm water.

***OIL POLLUTION ACT OF 1990 (OPA)***

The Oil Pollution Act (OPA) regulations supplement existing laws regarding the storage and handling of oil. As defined in OPA, Spill Prevention Countermeasure and Control (SPCC) Plans are required for facilities storing bulk oil. OPA also added requirements for facilities presenting a threat to navigable waters, including preparation of an Facility Response Plan (FRP) that prepares a facility for response to potential worst-case spills. OPA includes employee training requirements related to prevention of, and responses to releases.

***OCCUPATIONAL SAFETY AND HEALTH ADMINISTRATION (OSHA)***

The Occupational Safety and Health Administration (OSHA) regulations contained in Title 29 and the Cal-OSHA regulations codified in Title 8 contain employee safety provisions that attempt to minimize the hazards for employees in the workplace.

***TOXIC SUBSTANCES CONTROL ACT (TSCA)***

The Toxic Substances Control Act (TSCA) includes requirements for the storage, use, and disposal of Polychlorinated Biphenyls (PCB)-containing materials.

APPENDIX F  
HAZARDS AND HAZARDOUS MATERIALS BACKGROUND INFORMATION

### **DEPARTMENT OF TRANSPORTATION (DOT)**

Physical hazards, storage field maintenance and operations defined by the Department of Oil Gas and Geothermal Resources (DOGGR) are under the federal jurisdiction of the Department of Transportation (DOT). The DOT regulates the transportation of hazardous materials between states. Both federal and state agencies specify driver training requirements, load labeling procedures, and container specifications. The DOT also indirectly regulates the transportation of natural gas through pipelines according to the Natural Gas Pipeline Safety Act. The Act requirements, including designing pipelines to maximize safety (e.g., installing corrosion protection), routinely inspecting pipelines, preparing for possible emergencies, and reporting injuries and physical damage caused by accident, have been adopted by the California Public Utilities Commission (CPUC).

### **STATE**

Title 22 of the California Code of Regulations defines, categorizes, and lists hazardous materials and wastes. Title 22 defines a hazardous material as:

"a substance or combination of substances which, because of its quantity, concentration, or physical, chemical or infectious characteristics, may either (1) cause, or significantly contribute to, an increase in mortality or an increase in serious irreversible, or incapacitating reversible illness; or (2) pose a substantial present or potential hazard to human health or environment when improperly treated, stored, transported or disposed of or otherwise managed."

Hazardous wastes are categorized in Title 22 as either hazardous wastes, as defined in the Resource Conservation and Recovery Act (RCRA) or non-RCRA hazardous wastes. Title 22 lists chemical compounds that are presumed to make a material or waste hazardous to the environment.

### **CALIFORNIA WATER CODE (CWC)**

The California Water Code (CWC) includes provisions of the federal CWA and water quality programs specific to California. The CWC requires reporting, investigation and cleanup of hazardous material releases that could affect waters of the state (including storm waters).

### **CALIFORNIA ABOVEGROUND PETROLEUM STORAGE ACT**

The California Aboveground Petroleum Storage Act, which is implemented by the Regional Water Quality Control Boards (RWQCBs), regulates the storage of petroleum in aboveground storage tanks (ASTs) and requires construction methods and monitoring to prevent petroleum releases.

### **CALIFORNIA HEALTH AND SAFETY CODE SECTION 25534 (CAH&SC)**

Section 25534 of the California Health and Safety Code (CAH&SC) requires businesses that handle amounts of Acutely Hazardous Materials (AHMs) in excess of certain quantities to develop a Risk Management Plan (RMP). The RMP encompasses process hazards, potential consequences of releases, and documentation, auditing, and training relative to the AHMs that are above specified threshold



---

**APPENDIX F**

HAZARDS AND HAZARDOUS MATERIALS BACKGROUND INFORMATION

---

quantities at the generating station. Regulated AHMs may include aqueous ammonia and sulfuric acid, as well as other acutely hazardous substances.

***CALIFORNIA DEPARTMENT OF CONSERVATION, DIVISION OF OIL, GAS AND GEOTHERMAL RESOURCES (DOGGR) AND CPUC***

Physical hazards, storage field maintenance and operations within the Playa del Rey gas storage facility are under the jurisdiction of the California Department of Conservation, Division of Oil, Gas and Geothermal Resources (DOGGR) and the California Public Utilities Commission (CPUC). DOGGR regulates the operations and maintenance of natural gas storage fields, and certain aboveground piping is regulated by the CPUC. DOGGR manages oil and gas resources in California and for the Playa del Rey field. The City of Los Angeles has local responsibility and authority through land use permitting and zoning for both oil and gas production and quarry and mining operations. The City also has zoning jurisdiction through special use permits and overlays for oil and gas. Currently, SCG holds use permits and lands are currently zoned for residential (35 of the 36 lots) and commercial (1 of the 36 lots). Playa del Rey Gas Storage Facility (PDRGSF)

The Storage Field is regulated by a number of state and local agencies. The DOGGR has primary jurisdiction over gas storage operations. The storage field operates pursuant to a permit issued by DOGGR, which requires, among many other things, extensive reporting, inspections, and performance reviews. Oil production has been exercised in the Los Angeles area for over seventy years. Gas production has been exercised for over sixty years. Federal and state regulations have been established to manage current and abandoned operations. There are significant numbers of abandoned oil and gas wells throughout the Los Angeles basin. Several of these abandoned wells have buildings constructed over or adjacent to them, and their proximity may be concern for the potential for exposure to hazards if there is gas leakage from abandoned wells. The Playa del Rey Gas Storage Facility (PDRGSF) is the only operating gas storage facility left in the Los Angeles Basin.

A DOGGR Project Approval Letter defines requirements that are specific to the Playa del Rey storage field (1986). Environmental conditions and well safety equipment are inspected regularly. During these inspections, a DOGGR inspector looks for indications of any type of oil or gas leaks from wells, pipelines, pressure vessels, and tanks. They also witness testing of the automatic shut down equipment on each well. Storage project performance reviews take place annually. During these reviews, DOGGR engineers examine SCG records to ensure that all well and reservoir monitoring and leak survey requirements were met.

### **Storage Tanks**

Hazardous materials are typically stored in underground or aboveground storage tanks. Laws and regulations regarding underground storage tanks that are used to store hazardous materials (including petroleum products) require that owners and operators register, install, monitor, and remove their tanks according to established standards and procedures. Releases are to be reported. Owners of above-ground storage tanks containing petroleum products are required to prepare and implement spill prevention and response strategies, and to contribute to the Environmental Protection Trust Fund that is used to respond

**APPENDIX F**

**HAZARDS AND HAZARDOUS MATERIALS BACKGROUND INFORMATION**

to some spills. Proper drainage, dikes, and walls are required in order to prevent accidental discharges from endangering employees, facilities, or the environment.

### Well Abandonment Regulations and Policies

DOGGR has adopted regulations<sup>13</sup> for well abandonment to ensure that it is done safely and effectively. These regulations provide well abandonment procedures that prevent future migration of oil or gas from the producing zone and the upper zones, as well as protect groundwater. Furthermore, the DOGGR is charged with ensuring that public safety is not endangered. The DOGGR has the expertise and the authority to require whatever steps are deemed necessary to protect public safety, up to and including requiring SCG to cease operations and/or remove all gas from the field. They have approved SCG operations and monitoring program. As stated above, well abandonment is discussed in more detail within the geology section of this document.

Actually same as S. Salt Lake  
 FALSE

After subsurface abandonment is completed and the surface portions of the well are removed, SCG must test and remove soil that has been contaminated by oil or other well maintenance substances. At the end of abandonment operations, the DOGGR and the Los Angeles Fire Department will complete a final inspection of the well site. After this inspection, the DOGGR will review all of the abandonment records of the operator and will either provide a final abandonment approval or a notice of deficiency that must be corrected.

### Regulations Regarding Construction of Buildings Over Abandoned Wells

Future development of the lots would be subject to the requirements of local permitting agencies and would include compliance with all requirements for construction over abandoned wells. The regulatory requirements for building over abandoned wells are discussed in the Geology Section of this document (Section VII).

Other local agencies that have jurisdiction over the PDRGSF facilities or operations include the Los Angeles Fire Department, the South Coast Air Quality Management District, the Los Angeles County Sanitation District, and the Occupational Safety and Health Administration.

### GAS MIGRATION

#### Well Drilling in the Playa del Rey Oil Field and Natural Gas Storage Field

Drilling in the region began as early as 1921 (Davis, 2000b). Early holes drilled and abandoned in the area during 1925 and 1926 were not deep enough to reach the producing zones in the Schist Conglomerate. The discovery well for the Playa del Rey (PDR) oil field was completed in 1929. Primary field development continued through the mid-1930s. By the early 1940s production had reached its economic limit and operators abandoned oil production from the field.

In 1942, as part of the national war effort, the federal government condemned and took possession of approximately 240 acres of the PDR field area to use as a natural gas storage field. This gas storage field

<sup>13</sup> These regulations can be found in California Code of Regulations, Title 14, Chapter 4.

APPENDIX F  
HAZARDS AND HAZARDOUS MATERIALS BACKGROUND INFORMATION

was later transferred to the Reconstruction Finance Corporation in 1945. Then, in 1953, the Reconstruction Finance Corporation declared the field surplus and offered it for sale in 1953. The Southern California Gas Company was the successful bidder and assumed operations in late 1953.

Facilities were completed in 1956, and then gas was injected and stored at depths of about 6,200 feet within the Conglomerate Trap Zone. By July 1958, approximately 27 billion cubic feet (bcf) of cushion gas was stored. Since that time, numerous wells have been utilized for storage and retrieval of the gas. Currently, the storage field is operated through 54 wells directionally drilled from the lowlands and hilltop of PDR. Of these 54 wells, 25 are injection/withdrawal wells used to inject and extract gas, 8 are liquid (primarily water) removal wells, 3 are lateral migration wells to control gas movement, and 18 are observation wells used to monitor pressure and liquid saturation. SCG's facility for the PDRGSF is 0.2 mile north of Manchester Avenue.

### Types of Gases

The three types of gas that may exist within the geological and soil units underlying the project area are processed natural gas (or piped gas), biogenic (or swamp) gas, and thermogenic (field) gas. Biogenic gas is primarily methane with carbon dioxide and sulfide gases resulting from decomposition of organic material in former lagoon deposits or other sources. Thermogenic gas is generated at depth, when increased temperatures and pressures alter organic material. It includes a broad range of gas components (methane, propane, butane, ethane, etc.). In contrast, processed natural gas is primarily methane remaining from thermogenic gas after most of the heavier gas components are removed (usually less than 0.1% heavy thermogenic hydrocarbons). These gas types exhibit distinct chemical characteristics, which permits "finger-printing" of gases or differentiation between gas types. In addition to lacking heavier gas components (propane, butane, ethane, etc.), the presence of helium in detectable amounts is a primary fingerprint for natural gas imported from the central US and previously stored in the deep storage zone.

Natural gas can occur in subsurface environments as various phases. Understanding gas phases is important because each phase exhibits specific physical properties, and thus poses different flow characteristics. These phases include free gas, liquefied petroleum gas, and dissolved gas in both water and oil depending on pressures and temperatures. When evaluating the potential for shallow gases reaching the surface, the primary phases of concern are free gas and dissolved gas in groundwater.

### Migration Pathways

Studies have detected natural gas at the surface in the PDR area as well as areas overlying other oil fields. Surface gases can originate from biogenic, thermogenic, or storage sources, or a combination of these sources. Gas reaches the surface through various natural, man-made, or combination migration pathways.

Both biogenic and thermogenic gas were detected by ETI (2000) during a soil gas survey in the Playa Vista area. Following a second phase of evaluation ETI (2001) concluded "storage gases are not present in any of the methane anomalies observed east of Lincoln Blvd." Routine surface monitoring SCG wells found storage gases were reaching the surface through casing leaks and along the well casings in three

WHY  
ETI

FALS

CENTRAL PART OF FRAUD // FLEET RUST!

HAZARDS AND HAZARDOUS MATERIALS BACKGROUND INFORMATION

APPENDIX F

FALSE -> FRAUD OF FLEET RUST AGAIN!!! WHAT ABOUT HIGH LEVELS OF HELIUM?
Biogenic gas was detected in four abandoned wells in the PDR field area, resulting in re-abandonment of these wells to eliminate the leaks.

Major Pathways

FORESEEABILITY OF GAS MIGRATION

Man-made structures can convey gas to the surface from deep or shallow sources. A list of the most common man-made structures that could serve as vertical conduits include:

- Old abandoned oil and gas wells or dry holes, (abandoned prior to current DOGGR regulations)
Previously undocumented wells and dry holes
Existing water extraction or injection wells
Old abandoned water wells
Monitoring wells
Recently plugged and abandoned oil and gas wells (abandoned in accordance with current DOGGR regulations)

RELATE TO CRIMINAL CODES
PC 374.8 E 375(A) E(G)

Gas can also reach the surface through natural geologic features which may facilitate vertical, lateral, or oblique migration. The geologic features most likely to serve as potential pathways include:

- Surficial deposits
Porous and permeable formations
Aquifers
Fracture systems
Fault planes
Other geologic features and structures, such as unconformities

STORAGE RELATED TO PRESSURE!
BIG DANGER! ALSO, DIRECTLY RELATED TO PRESSURE!

GAS MONITORING REQUIRES

The potential gas migration reaching the surface is considered greatest through or along man-made structures. In general, geologic pathways are relatively "tight" in the "shallow" and storage zones. Fractures, faults, and spaces between individual grains are minimized due to the tremendous overburden pressure (the weight of the rock materials). Within the Project area, wells penetrate shallow and deep gas zones at various depths. (Once penetrated) a poorly constructed or abandoned well can serve as a conduit for upward migration of natural gas. Such conduits can develop as old wells deteriorate (over the 70 years), even when proper construction and abandonment methods have been applied.

Natural gas of biogenic, thermogenic, and storage sources can travel through a variety of man-made structures to migrate both vertically and laterally through the subsurface. In addition to oil and gas wells, both active and abandoned water wells can serve as vertical conduits, especially in the upper 1,000 feet of geological section. Utility trenches, storm drain systems and sewer lines provide lateral migration pathways, accumulation areas, and near-surface openings for natural gas release.

Natural Pathways

Various studies prepared by SCG, DOGGR, US Geological Survey (USGS), and California Geological Survey (CGS) suggest faults in the PDRGSF area. The USGS and CGS publish maps showing documented faults and reports describing such faults. No through-going active surface faults have been documented by either the USGS or CDMG. None of the information or reports reviewed for this study

---

APPENDIX F

HAZARDS AND HAZARDOUS MATERIALS BACKGROUND INFORMATION

---

present conclusive evidence of active surface faults in the immediate project vicinity. The Compton Blind Thrust Fault passes beneath the project site at much greater depths (>20,000ft), but no related fault is yet known to cut through the storage zone.

The Charnock fault is considered potentially active, and crosses the northeastern edge of the PDRGSF. Smaller, shorter faults and fracture systems are inferred in various units of the storage zone within the PDR field, but are not likely to transmit large volumes of crude oil or natural gas during short time intervals (days, weeks, or months). Naturally occurring subsurface migration of petroleum hydrocarbons typically takes place over extended periods of time, possibly tens or hundreds of thousands of years or more. Natural transmission of hydrocarbons through these systems is known within the oil and gas industry as "micro seeps." Upward migration of oil and gas through micro-seeps allowed hydrocarbon emplacement in shallow zones. Significant natural upward migration from the storage zone is unlikely during the productive life of the PDR field.

The original reservoir pressure in PDR field was 2,750 psi, which is within the range of normal pressure gradient for the storage zone depths (Davis, 2000). Operating pressures (maximum 1,700 psi) are about 38 percent lower than original reservoir pressures. Therefore, significant volumes of storage gas would not be expected to migrate to the surface through natural geologic features.

Past and proposed withdrawal of gas from the storage zone is not expected to cause downward movement of groundwater or other fluids from shallow zones. With decreased reservoir pressures, lithostatic forces (rock overburden pressures) become more dominant, further sealing (through compaction) any open fractures or void spaces in the cap rock. Thus, the potential for fluid or gas migration through geologic pathways either into or out of the storage zone is low.

Shallow gas may migrate through younger earth materials to reach the surface. Both Pleistocene and Holocene sedimentary deposits include many permeable horizons or zones. Both biogenic and thermogenic gas from shallow zones can migrate, both vertically and laterally, through these permeable layers. Gas migration would involve both free-phase and dissolved-phase gases (dissolved in water). In the Playa Vista area immediately northeast of the project site, the contact between the San Pedro Formation and overlying younger alluvium form a contact between geologic units that could affect both lateral and vertical subsurface fluid or gas movement.

Faults affecting the project vicinity are discussed above under Structure and Seismicity. Based on his review of geologic reports and well records for PDR field, Davis (2000b) concludes that there is no evidence for faults cutting through the primary or secondary seals, and there is no evidence of through going fracturing of the seal. In the project area, the northwest-southeast trending Charnock fault (potentially active) is the closest documented fault in the vicinity. It crosses through the area east of the PDRGSF and project site. Although it is possible that undocumented faults could exist and contribute to upward gas migration, rates would not be significant compared to leaking wells.

During well drilling, fractured zones were encountered in some boreholes. The type (open, closed, sealed) and extent of fracturing were not determined from the information available. This fracturing could be related to minor faulting in the immediate vicinity. Minor faults could affect subsurface gas

(11/1/24, 2005; 5:50 PM)

APPENDIX F  
HAZARDS AND HAZARDOUS MATERIALS BACKGROUND INFORMATION

migration, by either acting as barriers to lateral movement or pathways for vertical migration. Gas movement rates associated with minor faulting would not be significant compared to leaking wells.

The presence of shallow high-pressure gas zones encountered in the Playa Vista area indicates confinement of upward hydrocarbon migration from these intervals. At these locations, shale intervals within the Pico and Repetto Formation form effective cap rock or seals. If natural upward migration pathways were present, such as open fracture systems, gas in these shallow zones would exhibit a normal pressure gradient. High pressure was not released until these zones were penetrated during well drilling operations.

### Leaking Wells

Several factors contribute to possible gas migrations through abandoned and active wells such as original drilling, development and completion, operations and redevelopment, and abandonment. Many wells and dry holes were drilled during the exploration and early field development period. Dry or non-commercial wells were abandoned. Common practice by some operators in the 1920s through 1940s was to abandon wells and dry holes by filling them with construction debris or other items, such as telephone poles or railroad ties, prior to covering the surface with soil. These improperly abandoned wells have been unearthed during grading operations for construction sites located over old oil field in several areas of the Los Angeles Basin. Many of these wells and dry holes may not have been plugged to modern standards. Current abandonment requirements have developed since the 1950s to the more stringent standards today. Old dry holes and noncommercial wells have a high potential to provide migrations pathways.

Early in the history of oil and gas development in California and the United States, noncommercial or dry holes were drilled and abandoned without proper documentation and reporting, and some of these abandoned dry holes and wells may not have been recorded by the original drillers or DOGGR. Absence of unknown abandoned holes cannot be determined with certainty. Should they exist, they could serve as migration pathways.

Well construction, redevelopment, and abandonment deficiencies can contribute to gas migration problems. If cement bonds between the casing and surrounding natural formation do not form adequate storage seals, pressurized leakage is possible. Leakage through the annular space between casing and formation can occur under the following circumstances: lack of proper seals, inadequate seal or poor cement bonds with bore walls, channels within cement, deterioration of annular seals over time, and fracturing or cavitation of enclosing walls.

When present, shallow high-pressure gas zones can create problems for cement annular seals. During the well completion process, cement slurry is pumped into the annular space between the hole drilled (rock face) and casing to form a seal. Gas from shallow high-pressure zones can enter cement within the annular space during this process. Gas bubbles within the slurry weakens the cement and can compromise seals around these zones. In turn, poor seals could allow fluid migrations and enhance corrosion of both casing and cement in these areas. If large volumes of gas enter the annular space, vertical channels within the cement seal can also form. Marlow (1989) discusses the mechanisms contributing to compromised integrity of annular cement seals associated with gas zones.

**PROFOUAD****REASONS FOR NOT ALLOWING BUILDINGS OVER OLD WELLS**APPENDIX F  
HAZARDS AND HAZARDOUS MATERIALS BACKGROUND INFORMATION

Structural integrity of well components and seals is not permanent. Over extended periods of time, they eventually deteriorate. Both casings and seals are subject to corrosion caused by exposure to chemical attack, high and fluctuating pressures, high temperatures, and earthquakes. Steel casing is susceptible to rusting from saline and sour/sulfurous water produced along with the oil. Hydrogen sulfide of sour water and sour gas can corrode both steel and cement. Differential earth stresses (e.g., local earthquakes) can affect well integrity, even causing casing to collapse. Any deterioration of well integrity can lead to leaks.

**Abandoned Wells**

During past routine SCG surveys of abandoned wells, SCG determined that three previously abandoned wells on the Marina del Rey Peninsula (not part of the proposed project) would be re-abandoned following detection of leaking natural gas. Well designations and locations for these wells were not provided for this study. Although the origin of detected gas was biogenic and not the storage zone, SCG assumed responsibility and re-abandoned these wells to seal the leaks.

A leak was recently discovered in a well in the MDR area designated as Block No. 11 (while this well is not part of this proposed sale of property, it is in the vicinity of Cluster 12). This well was abandoned in April 1993 and sold with the surface parcel in 1997. The leak was discovered when DOGGR reviewed and tested the well prior to construction on the site. Preliminary analyses indicate that gas may be biogenic. Based on information available for this review, gas detected in this well is probably not emanating from the PDR storage facility. SCG will assume responsibility and re-abandon this well prior to site construction.

In the Playa Vista area east of the proposed project site, ETI (2000) conducted a soil gas survey. Several gas anomalies were identified during this survey. Analyses of samples collected indicates a combination of both biogenic and thermogenic gas origins. The presence or absence of storage gas was not confirmed during this study.

An examination of DOGGR maps showing locations of abandoned wells in the gas study area indicates that at least two of these soil gas anomalies correspond with locations of old abandoned wells or dry holes (Universal City Syndicate, Inc. Vidor No. 1 and Cooperative Development Co. Community No. 1). ETI (2000) indicates that a shallow dry hole (A.L. Kitselman, Del Rey No. 1) was also present in an area with surface gas anomalies. These old wells or dry holes may not be abandoned in accordance with current DOGGR regulations. In addition, the two deep abandoned holes penetrated shallow high-pressure gas zones during drilling. As such, they could provide vertical conduits through which thermogenic gas from shallow zones could reach the surface.

**Reported Leaking Wells: Southern California Gas**

A review of limited Southern California Gas Company records indicates past leaks and surface seepage documented in ten wells located in the Del Rey Hills areas. Following repairs in the ten identified wells, four of these wells experienced recurrences or new leaks. These wells and information on their respective leaks are summarized in Table F-1. Data provided for review was limited; therefore, this list of documented leaks may not be comprehensive.

INFO  
NOT  
PROVIDED  
BY  
SCG.  
BLOCK 11  
CENT

# REASONS FOR NOT ALLOWING BUILDINGS OVER OLD WELLS

APPENDIX F  
HAZARDS AND HAZARDOUS MATERIALS BACKGROUND INFORMATION

Structural integrity of well components and seals is not permanent. Over extended periods of time, they eventually deteriorate. Both casings and seals are subject to corrosion caused by exposure to chemical attack, high and fluctuating pressures, high temperatures, and earthquakes. Steel casing is susceptible to rusting from saline and sour/sulfurous water produced along with the oil. Hydrogen sulfide of sour water and sour gas can corrode both steel and cement. Differential earth stresses (e.g., local earthquakes) can affect well integrity, even causing casing to collapse. Any deterioration of well integrity can lead to leaks.

## Abandoned Wells

During past routine SCG surveys of abandoned wells, SCG determined that three previously abandoned wells on the Marina del Rey Peninsula (not part of the proposed project) would be re-abandoned following detection of leaking natural gas. Well designations and locations for these wells were not provided for this study. Although the origin of detected gas was biogenic and not the storage zone, SCG assumed responsibility and re-abandoned these wells to seal the leaks.

INFO NOT PROVIDED BY SCG.  
BLOCK 11 CENTRE

A leak was recently discovered in a well in the MDR area designated as Block No. 11 (while this well is not part of this proposed sale of property, it is in the vicinity of Cluster 12). This well was abandoned in April 1993 and sold with the surface parcel in 1997. The leak was discovered when DOGGR reviewed and tested the well prior to construction on the site. Preliminary analyses indicate that gas may be biogenic. Based on information available for this review, gas detected in this well is probably not emanating from the PDR storage facility. SCG will assume responsibility and re-abandon this well prior to site construction.

In the Playa Vista area east of the proposed project site, ETI (2000) conducted a soil gas survey. Several gas anomalies were identified during this survey. Analyses of samples collected indicates a combination of both biogenic and thermogenic gas origins. The presence or absence of storage gas was not confirmed during this study.

An examination of DOGGR maps showing locations of abandoned wells in the gas study area indicates that at least two of these soil gas anomalies correspond with locations of old abandoned wells or dry holes (Universal City Syndicate, Inc. Vidor No. 1 and Cooperative Development Co. Community No. 1). ETI (2000) indicates that a shallow dry hole (A.L. Kitselman, Del Rey No. 1) was also present in an area with surface gas anomalies. These old wells or dry holes may not be abandoned in accordance with current DOGGR regulations. In addition, the two deep abandoned holes penetrated shallow high-pressure gas zones during drilling. As such, they could provide vertical conduits through which thermogenic gas from shallow zones could reach the surface.

## Reported Leaking Wells: Southern California Gas

A review of limited Southern California Gas Company records indicates past leaks and surface seepage documented in ten wells located in the Del Rey Hills areas. Following repairs in the ten identified wells, four of these wells experienced recurrences or new leaks. These wells and information on their respective leaks are summarized in Table F-1. Data provided for review was limited; therefore, this list of documented leaks may not be comprehensive.



---

**ENVIRONMENTAL AND HEALTH HAZARDS  
DUE TO METHANE AND OTHER OIL FIELD  
GAS MOVEMENT THROUGH SOILS**

**By: Bernard Endres, Ph.D.**

**OVERVIEW:**

**Methane, and *OTHER* oil field gases, can easily move through cracks in rocks and through pore spaces in soils. The relative ease by which this can take place (viz., the soil's ability to transmit the gas) is measured in terms of *PERMEABILITY*. Accordingly, *POROSITY* and *PERMEABILITY* are important geological parameters regarding the fundamental understanding of gas migration within geological formations.**

**Furthermore, the underlying oil field characteristics must be understood in order to perform an environmental risk assessment, including health hazards.**

**GAS POCKETS AND COLLECTOR ZONES:**

**the rate of gas flux to the surface at any particular location. In addition, the percentage of pore space in the soil (“porosity”), and the “interconnectedness” of the pore spaces (“permeability”) will influence the rate of movement of the gases.**

**Gas flux can be measured experimentally at the surface using a flux chamber. This can be highly variable over the subject area because of the variable geological factors described above.**

#### **GROUND WATER MOVEMENT:**

**The movement of local groundwater can greatly influence both the upward and lateral migration of the oil field gases. For these reasons, a detailed hydrogeological study of the area is necessary. For purposes of environmental assessment, groundwater influences are crucial in the evaluation and interpretation of the experimental data.**

**For example, many of the environmental studies to evaluate soil contamination are carried out using relatively shallow soil probes that do *NOT* penetrate**

**below the near surface aquifer zones. Accordingly, before proper experimental interpretations can be given to the gas concentrations, the hydrogeological conditions must be well known. A profound example, is where the aquifer conditions are being continually influenced by the nearby tidal forces of the Pacific Ocean.**

**Furthermore, each of the oil field gas constituents has a different level of solubility in water. Examples are as follows:**

**WATER SOLUBILITY OF SELECTED HYDROCARBONS**

|                     | <b>WATER SOLUBILITY<br/>(AT 25°C)</b> | <b>MOLECULAR<br/>WEIGHT</b> |
|---------------------|---------------------------------------|-----------------------------|
| <b>BENZENE</b>      | <b>1780 mg/l</b>                      | <b>78</b>                   |
| <b>TOLUENE</b>      | <b>500 mg/l</b>                       | <b>92</b>                   |
| <b>P-XYLENE</b>     | <b>200 mg/l</b>                       | <b>106</b>                  |
| <b>O-XYLENE</b>     | <b>170 mg/l</b>                       | <b>106</b>                  |
| <b>ETHYLBENZENE</b> | <b>150 mg/l</b>                       | <b>106</b>                  |

**The ease and efficiency with which methane and other oil field gases move in the pore spaces of fractures affects how much of the gases can reach the surface. If the gases are able to move easily in the pore spaces, then the gases can travel great vertical, as well as horizontal distances. However, if the migrating gases come in contact with clay or silt, this will impede the gas flow, likely to cause high concentrations of the gases to collect in “pockets” or sometimes called “secondary collector zones.”**

**Also, a water table can impede the upward migration of the gases as a result of the *CAPILLARY* forces. These forces act as the gases attempt to pass through the “pore throat” spaces within the rock and soils.**

### **SPEED OF GAS MOVEMENT:**

**The method and speed of gas movement through soils (e.g., “gas flux”) is controlled by the amount of water present in the pore space. For example, the soil moisture content in the near surface soils can influence**

**The above chemicals also pose serious health hazards, and must be evaluated for the long-term health risks resulting from their presence in the near surface soil conditions.**

**Methane gas is the dominant gas that migrates to the surface from the underlying, or adjacent, oil field. However, the methane gas serves as a “carrier” gas for a number of other oil field gases, including Benzene, Toluene, Ethylbenzene and Xylene (viz., the “BTEX” chemicals).**

**HIGH RISK HEALTH HAZARDS OF THE MIGRATING GASES:**

**Methane serves as a carrier gas for benzene and toluene, along with other hazardous oil field chemicals. Benzene and toluene are on the so-called Governor’s List of Toxic Chemicals, enacted into California Law as Proposition 65 (viz., Health and Safety Code Section 25249.6).**

**Benzene is a known human carcinogen, which can cause cancer, leukemia, aplastic anemia and birth defects. Toluene is a neurotoxin that can damage the central nervous system, harm the immune system (especially for developing children) and can cause birth defects.**

**For these reasons, it is very important to evaluate all of the gas constituents within the near surface soil conditions. For example, the detection of high levels of methane gas in the near surface soil conditions, especially in an oil field location, indicates the high probability of finding other oil field chemicals that could be highly dangerous to public health and safety.**

#### **THE EXPLOSION HAZARD OF METHANE GAS:**

**Following the Ross Department Store Explosion, in the Fairfax area of Los Angeles in 1985, the City of Los Angeles adopted changes in the Building Code that required gas migration measures to be incorporated into new building construction undertaken in that area. These measures were also imposed on new**

**construction being undertaken on the huge Playa Vista real estate development currently underway near Los Angeles International Airport, in the Playa Del Rey and Marina Del Rey areas of the City of Los Angeles.**

**Although, the Playa Vista development is outside of the area designated in the City of Los Angeles Building Code (viz., applicable only to the Fairfax area, and sitting over the Salt Lake Oil Field), Playa Vista is over and adjacent to the Playa Del Rey and Venice Oil Fields.**

**Unfortunately, this so-called Methane Ordinance is *HIGHLY FLAWED* since it addresses only the explosion hazard presented by the migrating oil field gases. It does not address the health hazards posed by the presence of the above-identified Proposition 65 chemicals, or the other hazardous conditions to be discussed more fully below.**

**THE HYDROGEN SULFIDE PROBLEM:**

**Hydrogen sulfide gas is formed in an oil field setting as a result of the interaction between the upward migration of methane gas and high sulfate**

**levels within the groundwater. As a result of biogeochemical processes within the anaerobic (viz., absence of oxygen) sulfate-reducing zone of the underlying ground sediments, hydrogen sulfide is formed. This formation occurs as a result of the interaction between methane (viz., the hydrogen “donor”), sulfate-reducing bacteria, and the sulfate radical (viz.,  $\text{SO}_4$ ) of the groundwater.**

**The formation of hydrogen sulfide can be very prolific if the above three conditions are present in the correct chemical balance. For example, the Playa Vista site has been demonstrated experimentally to contain high levels of hydrogen sulfide within the near surface soil conditions. Also, the “new” Belmont school site (located near downtown Los Angeles, and over the City of Los Angeles Oil Field) has demonstrated high levels of hydrogen sulfide, especially at locations also exhibiting high levels of methane gas. The underlying water table at Belmont has been confirmed to contain high levels of sulfide, as also exists at Playa Vista.**



**These correlations have provided important experimental confirmation of the necessity to evaluate the environmental hazards posed by hydrogen sulfide, in connection with the migration of oil field gases to the surface.**

**A gas seep location at the north end of the City of Newport Beach (located in Orange County, in Southern California) also exhibits all of the above characteristics. Namely, upward migration of oil field gases (dominated by methane) containing large quantities of hydrogen sulfide when measured in the near surface. However, it appears that the hydrogen sulfide does not originate from the oil field (located laterally over a mile away), but forms closer to the surface where the oil field gas interacts with sulfate reducing bacteria.**

#### **HYDROGEN SULFIDE AS A NEUROTOXIN:**

**Kaye H. Kilburn, M.D., a medical researcher with the University of Southern California Medical School has been the leading researcher in the world regarding the health consequences of hydrogen sulfide on brain**

**functions. He has published widely on the subject including the text “Chemical Brain Injury,” Van Nostrand Reinhold Publisher (1998), and “Evaluating Health Effects From Exposure To Hydrogen Sulfide: Central Nervous System Dysfunction,” published in “Environmental Epidemiology Toxicology” (1999) 1, 207-216**

**His research has demonstrated that levels of hydrogen sulfide exposure as low as one part per million (1 ppm) can cause permanent brain damage.**

**The levels that are being measured at Playa Vista, the “new” Belmont school site, and at the gas seep in Newport Beach far exceed this level. Accordingly, it is clear that this enormous health hazard has not been adequately assessed.**

**HYDROGEN SULFIDE CAUSES SEVERE CORROSION:**

**From an engineering design perspective, hydrogen sulfide is one of the most corrosive agents known to mankind. In the petroleum industry, the Society for Petroleum Engineers (SPE), for example, has declared**

**that there is no known engineering solution to the corrosion problems caused by hydrogen sulfide. Although mitigation measures are available, these cannot be used where installations were completed many years before the mitigation measures were “invented.”**

**For example, the old oil wells that were drilled in the 1920s and 1930s did not use steel casings or cement seals that were resistant to the corrosive effects of hydrogen sulfide. Many of these wells were abandoned using cement plugs that are now vulnerable to deterioration from corrosion. Furthermore, these wells have demonstrated a long history of leaking oil field gases to the surface as a result of the direct permeable pathways created by the well bores.**

**Accordingly, an extremely important part of any environmental assessment to be performed within an oil field setting is to evaluate the condition of the wells, and perform an ongoing assessment of soil gas monitoring in the vicinity of each and every well.**

**This must be ongoing since it must be anticipated that the well casing and cement used to seal the wells will eventually fail because of the ongoing corrosion, and ground movement.**

**SUBSIDENCE CAN CAUSE WELL SEAL FAILURE:**

**Another important consideration in the evaluation of the environmental hazards posed by migrating gas from oil and gas fields is the ongoing presence of subsidence caused by fluid production. These factors contribute to the subsidence problem, or vertical ground movement, within an oil field: (1) fluid production of oil; (2) fluid production of brine water (usually far exceeding the oil production); and (3) the reduction of pore pressure within the oil field reservoir as a result of oil, brine water and gas production.**

**This hazard is often totally ignored, especially relating to the oil and gas well leak integrity. In reality, the subsidence interacts with the corrosion of the steel casings and the cement used to seal the wells from leaks, causing premature seal failure of the wells. This**

**problem is especially serious where the well completion occurred in the early years of oil field production, and the subsequent subsidence, soil compaction, and earth movement has occurred around the well bore seals.**

**The most serious problems arise, for example in the Los Angeles basin, where many homes have been constructed directly over the old well bores. If a leak develops, the only way to access the well in an attempt to repair the leak, is to tear the house down. Failure to correct the leak could imperil the entire neighborhood.**

**In particular, the City of Los Angeles has largely ignored this enormous danger, and has routinely granted building permits that allow construction of homes directly over the old oil and gas wells. There has been enormous pressure and lobbying efforts carried out by the real estate interests in order to facilitate the granting of the building permits. In most instances, no mitigation measures have been imposed upon the builders by the City of Los Angeles.**

**The most serious consequence of these dangerous building practices is that no consideration is being given to the health hazards posed by the upward migration of toxic oil field gases, including Proposition 65 chemicals. For example, there have been no real estate disclosures of these health hazards, and real estate developers continue to use “influence peddling” techniques to get their projects routinely approved at City Hall.**

**UNDERGROUND GAS STORAGE OPERATIONS:**

**The ultimate example of these environmental hazards that are posed by oil and gas field operations is the Playa Del Rey underground gas storage field operated by Southern California Gas Company (“SOCALGAS”). This gas storage field is operated within the partially depleted oil fields of Playa Del Rey and Venice, located under the residential communities of Playa Del Rey and Marina Del Rey, just north of the Los Angeles International Airport.**

**These two oil fields saw rapid development when over 300 oil wells were drilled and completed in the 1920s and 1930s. Huge fluid production and pressure decline contributed to nearly two feet (2 ft.) of ground subsidence as a result of cumulative oil, water and gas production through the year 1970. No subsidence measurements have been taken since 1970, although fluid production has continued to the present time.**

**Large 12,500 horsepower compressors are used to inject natural gas transported into the field by pipeline from other areas of California, Texas, Oklahoma, Wyoming and Canada. The gas is injected into the old oil fields at pressures approaching 1,700 pounds per square inch. Many of the old oil wells in the area have been observed to be leaking gas to the surface.**

**However, many of the over 300 old oil wells have had homes constructed directly over the wells. This has prevented access to the wells for monitoring, and in performing repairs to control the gas leaks. However, the area is almost entirely underlain by a thick (almost 150 feet deep) gravel layer that allows the leaking wells**

**to individually go largely undetected for leaks. Namely, once the upward migrating leaking gas, associated with each well, reaches the gravel zone it rapidly spreads out laterally within the highly permeable gravel zone.**

**The gravel zone extends easterly along the path of the old Los Angeles Riverbed, and follows the current path of the county flood control channel. In terms of permeability, this gravel zone provides an excellent conduit for the gas to move easterly, and directly under the Playa Vista real estate development currently under construction.**

**This movement has been facilitated by the tidal action of the ocean, which acts as a “piston” (by analogy to an automobile engine) in providing a periodic, and pulsating, energy source in moving the gas from the location of the leaking wells, easterly under the Playa Vista development. At low tide, oil field gas rapidly moves up the old oil field well bores. At high tide the gas is “pushed” easterly as the rising ocean level influences the pressures within the gravel zone.**



**Oil field gas levels exceeding ninety percent (90%) by volume have been routinely measured in the soil conditions directly under the Playa Vista development. Also, soil probes that have been placed into the gravel zone to allow measurement of gas volumes have recorded flow rates exceeding twenty liters per minute (20 l/min). These flow rates did not significantly diminish over several weeks of ongoing measurements, demonstrating the enormity of the gas migration problem.**

**Based upon a large body of experimental evidence, it is believed that the near surface oil field gas found at Playa Vista represents the largest known oil field gas seep to be found anywhere in the world. This is especially troubling, since the City of Los Angeles has allowed construction to proceed directly over this gas seep without requiring an investigation of the health hazards, or an investigation of the obviously leaking oil wells that are interconnected with the high pressure underground gas storage operation of SOCALGAS.**

**In addition to Playa Vista, the City of Los Angeles has allowed many homes, including homes under construction at this time, to be built directly over the old oil wells.**

### **CONCLUSIONS**

**The purpose of this paper has been to identify the steps that must be taken in order to properly evaluate the environmental and health hazards posed by attempting to construct residential communities over old oil fields and/or underground gas storage operations. Gas migration to the surface along old well bores, and along geological faults, must be considered as an ongoing threat for the lifetime of the project.**

**Methane gas represents the most prevalent of the oil field gas constituents, and can create a serious explosion hazard, especially if it is to migrate into a confined space of a building or structure. However, methane also serves as a carrier gas for other oil field chemicals including benzene and toluene that are highly dangerous to human health. Benzene is a known**

**human carcinogen, can cause cancer, leukemia and aplastic anemia, and can cause birth defects. Toluene is a neurotoxin that can cause brain damage, central nervous system disorders and birth defects.**

**Large quantities of methane gas migrating to the surface can interact with sulfate reducing bacteria giving rise to the ongoing generation of hydrogen sulfide in the near surface environment. Hydrogen sulfide is a neurotoxin, which can cause permanent brain damage at very low levels (e.g., 1 ppm).**

**In addition, hydrogen sulfide is highly corrosive, having the capability to destroy the integrity of the steel casings and concrete seals of the old oil wells that are the major source of the leaking gases.**

**It is urgent that proper disclosure be made of these conditions so that the innocent victims of these real estate transactions can take appropriate steps to protect themselves. Furthermore, the oil field operators, and the governmental entities responsible for performing oversight of these operations, must be held**

**accountable where they have failed to act responsibly  
regarding these dangerous conditions.**



CANADIAN INTERNATIONAL  
PETROLEUM CONFERENCE

**PAPER 2002-105**

**ENVIRONMENTAL HAZARDS AND MITIGATION**  
**MEASURES FOR OIL AND GAS FIELD OPERATIONS**  
**LOCATED IN URBAN SETTINGS**

by: **George V. Chilingarian, Ph.D.**  
**Professor of Civil and Petroleum Engineering**  
**University of Southern California**

**Bernard Endres, Ph.D.**  
**Oil and Gas Environmental Consultant**  
**Los Angeles, California**

**Prateep Pokinwong, Ph.D. Student**  
**University of Southern California**

**ABSTRACT**

This paper presents a methodology for evaluating the environmental hazards posed by gas migration from oil and gas reservoirs, or underground natural gas storage facilities, and into the near-surface environment. Geological faults and improperly completed or abandoned well bores (e.g., due to poor cementing practices) are described as the primary pathways by which the gas can reach the surface. Furthermore, the gas migration problem can be exacerbated by such factors as subsidence, earthquake activity and well corrosion.

Soil gas monitoring, geochemical gas fingerprinting and geological profiling are used in order to identify the magnitude and location of the environmental risks. Shallow and deep soil probes are used in order to characterize the near-surface hydrology, and to identify possible collector zones where gas concentrations can build to dangerous levels.

These techniques have proven to be important in the planning for and design of mitigation systems necessary to protect residential and commercial properties from the migrating gases. For example, some jurisdictions have imposed regulatory controls and design requirements regarding the installation of gas mitigation systems. Also, these methods are important in establishing safe procedures for the operation of oil and gas fields, or underground natural gas storage facilities.

A number of case histories are discussed that have been used by the authors to validate the methodology, and to illustrate the seriousness of the problem. A clear case is made for the need to perform ongoing monitoring for these conditions, especially in an urban setting.

## INTRODUCTION

The major paths for vertical migration of gas are formed by natural faults and fractures in the rock formations that overlie the reservoir. Natural lithification processes and tectonic activities formed these breaks or channels. These are illustrated in Figure 1 as subtending zones I, II, and III. However, in many geological settings, these fault zones can be discontinuous, but still allow the gas to literally hopscotch from one fault to another, or to act in conjunction with leaking wellbores in the same manner.

Wellbores of operational, idle or abandoned wells often result in literally pipeline flow of large volumes of gas to the surface. This is an especially serious problem where the well, usually in the annular space between the drill hole and the casing, was not properly sealed with cement. Also, the wellbore may have been hydraulically fractured during the cementing phase of well completion. Vertical fractures may extend for tens of feet from the wellbore depending upon the characteristics of the formation and the injection pressures used for placement of the cement. The cement will fill some of the larger fractures surrounding the casing, but the cement particles cannot enter the smaller fractures away from the wellbore.

## **SOURCES OF GAS FOR MIGRATION**

During the course of oilfield production, fluid is produced from the reservoir causing a drop in pressure. This liberates the gas held in solution, and allows the gas to migrate. The free gas can migrate upward due to differences in the specific weight between the gas and the surrounding fluids (viz., upward buoyancy forces). Figure 1 illustrates the migration of gas from the reservoir to secondary collector zones, and eventually to the surface.

Initially, the gas is trapped below the caprock within the reservoir, forming a free gas zone. However, this free gas can escape through the caprock due to natural fractures in the caprock or man-induced fractures. Man-induced fractures include: wellbores penetrating the caprock during drilling, fracturing pressures occurring during oilfield operations, or by subsidence resulting from production of fluids from the reservoir.

Well completion practices rely upon squeezing cement slurry into the annular space between the drillhole and the steel casing. However, the inevitable movement of the rock formation resulting from the subsidence can destroy the intended sealing joint at the caprock interface. Once through the caprock, the gas can follow faults and fractures, as illustrated by Zone III, in Figure 1. In Zone III, secondary gas traps can often be found where layers of shale or other impervious layers slow down the upward migration of gas and permit it to gather in pockets. Figure 2 is presented to illustrate the interaction between subsidence and gas migration.

In secondary and tertiary recovery operations, water is often injected under high pressure into the reservoir to increase the production of oil. This water displaces the free gas in the reservoir, forcing the gas to migrate under this pressure influence. This free gas is then able to migrate along the paths described above, toward the surface.

### **The 1985 Fairfax Explosion and Fires**

The phenomenon of natural gas migrating to the earth's surface from oil and gas field reservoirs via geological faults, fractures and well bores is a serious environmental problem. An explosion hazard is created if the gas collects in a confined space and reaches a five percent (5%) mixture ratio

with air (viz., the lower explosive limit for natural gas). The Ross Department Store in the Fairfax area of Los Angeles, California exploded on March 24, 1985, seriously injuring 23 people. Fires burned for days through cracks in the sidewalks and parking lots until a vent well was drilled to relieve the pressure build-up. Extensive investigations, including gas fingerprinting, confirmed that the gas had migrated to the surface along faults and poorly maintained well bores. Shallow soil gas probe holes were installed to monitor any future build-up of gas. In 1989 these gas monitoring wells indicated that large volumes of gas were again building up under the site. Fortunately, the area was evacuated immediately. It was discovered that the single vent well, that had been installed to vent the gas, had become plugged with silt at the slotted interval depth of 80 feet.

Other serious gas seeps have occurred in this area over many years. It is also the location of the famous La Brea Tar Pits where gas and oil continually migrate to the surface along the 6<sup>th</sup> Street Fault. This site has been used by the authors as a large “natural laboratory” to study and research the phenomenon of gas migration discussed in this paper. Over the past 15 years, this research has been expanded to address similar gas migration problems located in many parts of the world. This paper will provide an overview of these findings. References 1 through 5 provide a detailed treatment of these topics, including an analytical formulation of the gas migration mechanisms.

### **THE 2001 HUTCHINSON, KANSAS EXPLOSION AND FIRES**

Research on these topics is continuing at the University of Southern California, including at the graduate student level. This is expected to contribute important new information to the understanding of the geological, geochemistry and hydrogeology principles that control gas migration. The most recent incident that is under investigation is the natural gas explosion that destroyed the downtown area of Hutchinson, Kansas on January 17, 2001. The next day, natural gas exploded under a mobile home park outside of the city, killing two people. Gas and water geysers reached heights of 30 feet. The gas leaks were traced to an underground natural gas storage field located nearly seven miles from the explosion sites. The gas had migrated through geological faults and permeable formations from leaking well bores at the storage site. Investigation has revealed that virtually no monitoring was in place in order to prevent this disaster. Worse yet, the emergency



response teams had no clue as to the cause of the disaster. For example, the fire department was unable to extinguish the flames, illustrating the lack of preparedness for such an event. In the case of the 1985 Fairfax explosion, the fire department had been called, and had responded to gas odors in the area 30 minutes before the explosion. Because of their lack of preparedness, they mistakenly believed it was sewer gas, and returned to the fire station. Shortly thereafter, the alarm was sounded to respond to the explosion and fire that devastated the area that they had just returned from.

### **ENVIRONMENTAL HEALTH HAZARDS OF CERTAIN OIL FIELD CHEMICALS**

Additional concerns regarding the environmental hazards of oil and gas migration in urban areas are the carcinogenic, toxic and neurotoxin constituents that are contained within the oil field gases. These include the so-called BTEX chemicals comprising benzene, toluene, ethylbenzene and xylene. For example, benzene and toluene are contained on the so-called Governor's List of toxic chemicals within the State of California, and require a posting of warning signs to the public under the Proposition 65 environmental laws. Benzene is a known human carcinogen, and can cause blood disorders, including aplastic anemia and leukemia, as well as cancer. Benzene and toluene can cause birth defects. Both chemicals are highly volatile, and can easily transform from the liquid crude oil state into the natural gas state (e.g., associated gas), especially under reservoir pressure conditions.

This also becomes a serious problem in partially depleted oil fields that have been converted to underground natural gas storage operations. The storage gas is pumped into the oil field reservoir under high pressure. Frequently, 60% to 70% of the original crude oil still remains in place. When the storage gas comes in contact with the crude oil, aromatic hydrocarbons are transferred from the crude oil to the natural gas stream, enhancing the presence, particularly, of benzene and toluene. When the storage gas is retrieved to the surface for customer delivery, the gas must be processed through scrubbers and dehydration surface equipment. This provides an opportunity for these chemicals to escape into the atmosphere as fugitive emissions, or intentional releases. As a minimum, vapor recovery systems are necessary to control fugitive emissions. Billions of cubic feet of

storage gas can be withdrawn from inventory over a short period of time, increasing the health hazard risks to the surrounding community.

Furthermore, the natural gases that escape to the surface along well bores, faults and pipeline leaks will contain these health hazard chemicals. Also, workers need to be protected against these hazards, especially from long-term exposure.

### **HYDROGEN SULFIDE ENVIRONMENTAL HAZARDS**

Another serious problem is caused by the hydrogen sulfide formation that can occur when the leaking natural gas stream interfaces with high sulfate levels in the near-surface water table. This can give rise to the perpetual generation of hydrogen sulfide through microbial alteration under anaerobic sulfate to sulfide reducing conditions. Hydrogen sulfide is not only highly corrosive, but is a neurotoxin, that must be considered a health hazard even at levels as low as 1 ppm (Kilburn, 1998; Kilburn, 1999).

The corrosive conditions of hydrogen sulfide on both steel casings and cement are well known (Craig, 1993). However, oil field operators, especially regarding the longevity of well completions and well abandonments, often ignore the long-term consequences of hydrogen sulfide, and other corrosive soil conditions. Namely, the steel casings and cement completion practices can be expected to develop gas leaks to the surface as a result of future aging. Accordingly, it would be ill advised to allow building over abandoned well bores, regardless of how carefully they were abandoned with cement seals and plugs. Also, access to the wells with oilfield drilling rigs would be necessary in order to repair leaks that could develop at any time in the future.

Although this research has been devoted to evaluating the environmental hazards of gas migration, these same topics are important regarding near-surface exploration for oil and gas. In fact, the research methodology – especially soil probe studies – evolved originally from this exploration technology point of view. Namely, near-surface exploration for petroleum is based on the detection and interpretation of a great variety of natural phenomena occurring at or near the land surface or sea floor and attributed, directly or indirectly, to hydrocarbons migrating upward from leaky reservoirs at depth. Development of surface exploration methods began in the early 1930's with chemical analysis of gaseous hydrocarbons in

soil air. It has since expanded to include a wide range of geochemical, geophysical, mineralogic, microbiological and other types of anomalies (Toth, 1996).

### **MITIGATION SYSTEMS OVERVIEW**

Mitigation systems, both passive and active, have been developed in recent years in an attempt to cope with the gas migration hazards discussed in this paper. Many of these remain unproven. For example, the most common procedure is to install a geomembrane or plastic liner under the footprint of the structure being built in order to capture the upward migrating gases. Perforated pipes are installed in a gravel blanket located under the membrane in order to vent the gases that are collecting below the structure. These systems have demonstrated a high failure rate. The membranes can become punctured during installation, and/or develop leaks around the multiple penetrations that must accommodate utility and electrical lines, elevator shafts and pilings used for foundations. Gas detectors, used in conjunction with the membranes, require ongoing maintenance and calibration.

These mitigation systems have typically not been designed to deal with the health hazards of the migrating gas, but only to prevent a catastrophic explosion. This is a serious oversight, since the most dangerous chemical constituents of the leaking gas are heavier than air. For example, benzene, toluene and hydrogen sulfide are all heavier than air, and will tend to concentrate at ground level, and lower elevations, creating an inhalation hazard to those living and working in the area.

In summary, ongoing monitoring for the prevention of explosions and fires is essential, along with monitoring for health hazard conditions. The latter requires, at least, an order of magnitude lower threshold detection limits to protect against an inhalation health hazard.

### **NATURAL GAS STORAGE FIELDS**

It has become common practice to utilize depleted oilfields for the purpose of storing large volumes of natural gas underground. It is more economical to store gas in underground reservoirs than construct large

delivery lines, typically from out-of-state sources, that would be capable of satisfying peak demands. Gas is purchased and delivered to the storage field during non-peak demand periods, and retrieved from the storage field during high demand periods, such as during cold spells.

Underground gas storage facilities utilizing old, depleted oil and gas fields are subject to the same gas migration hazards as discussed above, but are often times more serious. The existing wellbores and well completions were not designed to withstand the high pressures that most gas storage facilities are operated at, nor the cyclical variations in pressure experienced by the seasonal high and low operating pressures. For example, during inventory draw-down the cement seals at the bottom of the casing can fail, causing shoe leaks and other seal damage.

Abandoned wells associated with the prior oil or gas field usage, are difficult, if not impossible to reenter and seal in order to prevent gas leakage. Also, since these wells do not allow direct monitoring, gas seepage can be detected only at the surface. However, the leaking gas can spread out and migrate along fault planes, and/or experience lateral migration within the shallow water table, before ever reaching the surface. This can act to conceal the true dangers of the leaking wells. These problems require the placement of deep soil probes, positioned immediately adjacent to the well bores. Also, gas levels within the near-surface water table require monitoring. Field experience has demonstrated that the near-surface water table can serve as a temporary barrier for the upward migration of gas. Often, the gas will collect below the water table, and spread out laterally before eventually reaching the surface.

For these reasons, it is important to perform a detailed characterization of the near-surface hydrology, including gas concentrations, free gas volumes and water movement directions. The individual gas constituents (e.g., methane, ethane, propane, etc.) have different solubility levels, and must be accounted for when attempting to characterize the origin of the leaking gases.

Gas fingerprinting studies must account for a number of near-surface gas alterations in order to properly interpret the source of the leaking gas. The primary adjustment factor is to account for the mixing between the native oilfield gas and the gas storage gas during migration using a so-called

mixing line. Also, near-surface mixing with biogenic gas can alter the characterization of the gas.

Underground gas storage facilities are frequently located in urban areas where gas, migrating to the surface can cause serious environmental problems. Examples include the following:

(1) MONTEBELLO GAS STORAGE FIELD, CALIFORNIA

The Montebello Oilfield, located in Southern California, was utilized by a gas company to store large volumes of natural gas in a partially depleted oilfield. Prior to converting the Montebello field to a gas storage facility, many oil wells had been abandoned using standards that were based on 1930's vintage technology. The old oilfield also contains several fault planes that are potential paths for gas migration.

The gas company began storing gas in a portion of the Montebello Oilfield in the early 1960's. By the early 1980's, significant gas seepages were discovered at the surface within a residential housing area. The gas seepages endangered homes, requiring evacuation of families. Some of the homes had to be torn down in order to provide access to leaking wells, that were attempted to be reabandoned. Monitoring of the near-surface water table for gas concentrations was undertaken on an emergency basis. Also, gas was found leaking up under the City Hall front lawn.

Because of the endangerment to the homes, and the huge economic losses suffered by the gas company from the lost gas, this storage facility has been closed.

(2) PLAYA DEL REY GAS STORAGE PROJECT

The Playa del Rey Oilfield was converted into a gas storage field in 1942. Shortly thereafter, storage gas was discovered migrating into the adjoining Venice Oilfield at the reservoir level of approximately 6,000 feet. Gas began migrating when the differential pressure reached approximately 300 psi. The storage field has been operated continuously to the present time, with storage gas pressures reaching approximately 1700 psi. A study, performed by the gas company in 1953, estimated that 25% of the injected gas was migrating to the adjoining Venice Oilfield. The operational procedure is based on capturing as much of the leaking gas as possible, and returning it to the primary storage field on an ongoing basis. This requires

numerous old oil wells to be used as recapture gas wells, in order to return the leaking gas.

Over 200 abandoned oil wells are in the area, which used 1930's era technology for the well completions. High-density housing has been built throughout the area, with many homes constructed directly over the old abandoned wells. Virtually no mitigation measures have been provided to deal with the gas migration hazards.

Recent soil gas studies have revealed gas concentrations as high as 90%, within the near-surface soil conditions. Soil probes and vent wells that have been drilled into the near-surface aquifer have measured gas flow rates as high as 25 to 30 liters per minute. One soil gas measuring expert has characterized the area as having the largest gas seep to be found anywhere in the world.

The City of Los Angeles has only recently begun to require mitigation systems to be installed in new construction, but only in the extremely high gas zones. The lessons learned from the Fairfax gas explosion, and the more recent Hutchinson, Kansas gas explosions have been largely ignored.

## CONCLUSIONS

If future disasters are to be averted, careful attention must be given to the monitoring for oilfield gas migration hazards. Furthermore, addressing the health hazards posed by certain chemical constituents such as benzene, toluene and hydrogen sulfide requires much lower detection thresholds to be used for monitoring purposes: within the 1 ppm range. Mitigation systems have not proven to be capable of dealing with these extreme hazards.

The main conclusions to be drawn from this paper can be summarized as follows:

- 1) The primary force controlling the migration of gas to the surface is the difference between the specific weight of water and that of gas (viz., the buoyancy force).

- 2) Gas migration occurs along faults, and behind wellbore casings to the surface. The volume of gas migration toward the surface is directly related to the type and width of the path along which it migrates.
- 3) Gas migration can create surface hazards if the gas is allowed to concentrate in localized collector zones (secondary traps), including the collection in shallow water tables.
- 4) It is not advisable to build over abandoned wellbores. Over time, the cement and well casing will deteriorate resulting in the creation of paths for gas migration to the surface. The migrating gas is both an explosion hazard, and a health risk, because of the presence of chemicals that can cause cancer, birth defects and central nervous system dysfunction.
- 5) Underground natural gas storage facilities have demonstrated a long history of gas migration problems. Gas migration hazards are aggravated because of the high reservoir pressures. Experience has shown that these facilities should not be located anywhere close to urban settings. The Hutchinson, Kansas gas explosion demonstrated that the storage gas can migrate many miles (in that case, seven miles to the explosion site).
- 6) To avoid catastrophic events as described in this paper, a fundamental awareness and understanding of the gas migration hazards and paths of migration would permit taking preventative steps. A detailed risk assessment needs to be performed for existing facilities, including the development of an emergency response plan.

These results have been presented so that individuals, and responsible governmental entities, will begin to take the necessary steps to protect the public health and safety from these dangers.

## REFERENCES

1. KHILYUK, L.F., CHILINGAR, G.V., ENDRES, B.L., and ROBERTSON, J.O., 2001. Gas Migration – Events Preceding Earthquakes, *Butterworth-Heinemann Publisher, 225 Wildwood Ave., Woburn, Massachusetts.*
2. GUREVICH, A.E., ENDRES, B.L., ROBERTSON, J.O., and CHILINGARIAN, G.V., 1993. Gas Migration from Oil and Gas Fields and Associated Hazards, *J.Pet.Sci.Engr., 9:223-228.*
3. GUREVICH, A.E., and CHILINGARIAN, G.V., 1993. Subsidence Over Producing Oil and Gas Fields, and Gas Leakage to the Surface, *J.Pet.Sci.Engr., 9:239-250.*
4. KATZ, S.A., KHILYUK, L.F., and CHILINGARIAN, G.V., 1994. Interrelationships Among Subsidence Owing to Fluid Withdrawal, Gas Migration to the Surface and Seismic Activity. Environmental Aspects of Oil Production in Seismically Active Areas. *J.Pet.Sci.Engr., 11:103-112.*
5. ENDRES, B.L., CHILINGARIAN, G.V., and YEN, T.F., 1991. Environmental Hazards of Urban Oil Field Operations. *J.Pet.Sci.Engr., 6:95-106.*
6. CRAIG, B.D., 1993. Sour-Gas Design Considerations, *Society of Petroleum Engineers, Inc., Monograph Volume 15.*
7. TOTH, J., 1996. Thoughts of a Hydrogeologist on Vertical Migration and Near-Surface Geochemical Exploration for Petroleum, *AAPG Memoir 66, p.279-283.*
8. HOLYSH, S., and TOTH, J., 1996. Flow of Formation Waters: Likely Cause for Poor Definition of Soil Gas Anomalies Over Oil Fields in East-Central Alberta, Canada, *AAPG Memoir 66, p.255-277.*
9. ALLISON, M.L., 2001. The Hutchinson Gas Explosions: Unraveling a Geologic Mystery, *Kansas Bar Association, 26<sup>th</sup> Annual KBA/KIOGA Oil and Gas Law Conference, vi, p.3-1 to 3-29.*
10. KILBURN, K.H., 1998. Chemical Brain Injury, *Van Nostrand Reinhold Publisher.*
11. KILBURN, K.H., 1999. Evaluating Health Effects From Exposure to Hydrogen Sulfide: Central Nervous System Dysfunction, *Environmental Epidemiology and Toxicology 1, p.207-216*



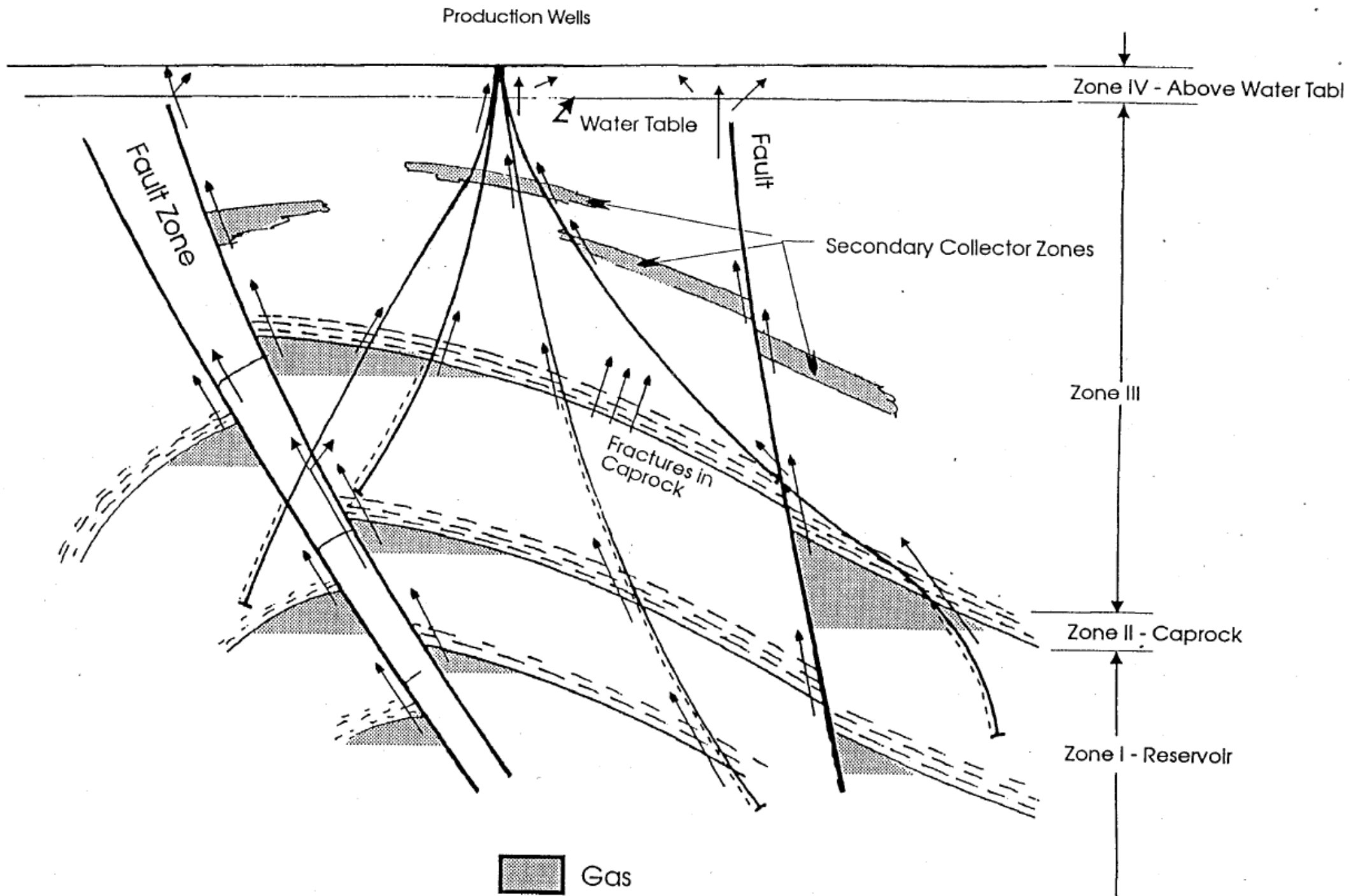

# POTENTIAL PATHS OF GAS MIGRATION

FIGURE 1.

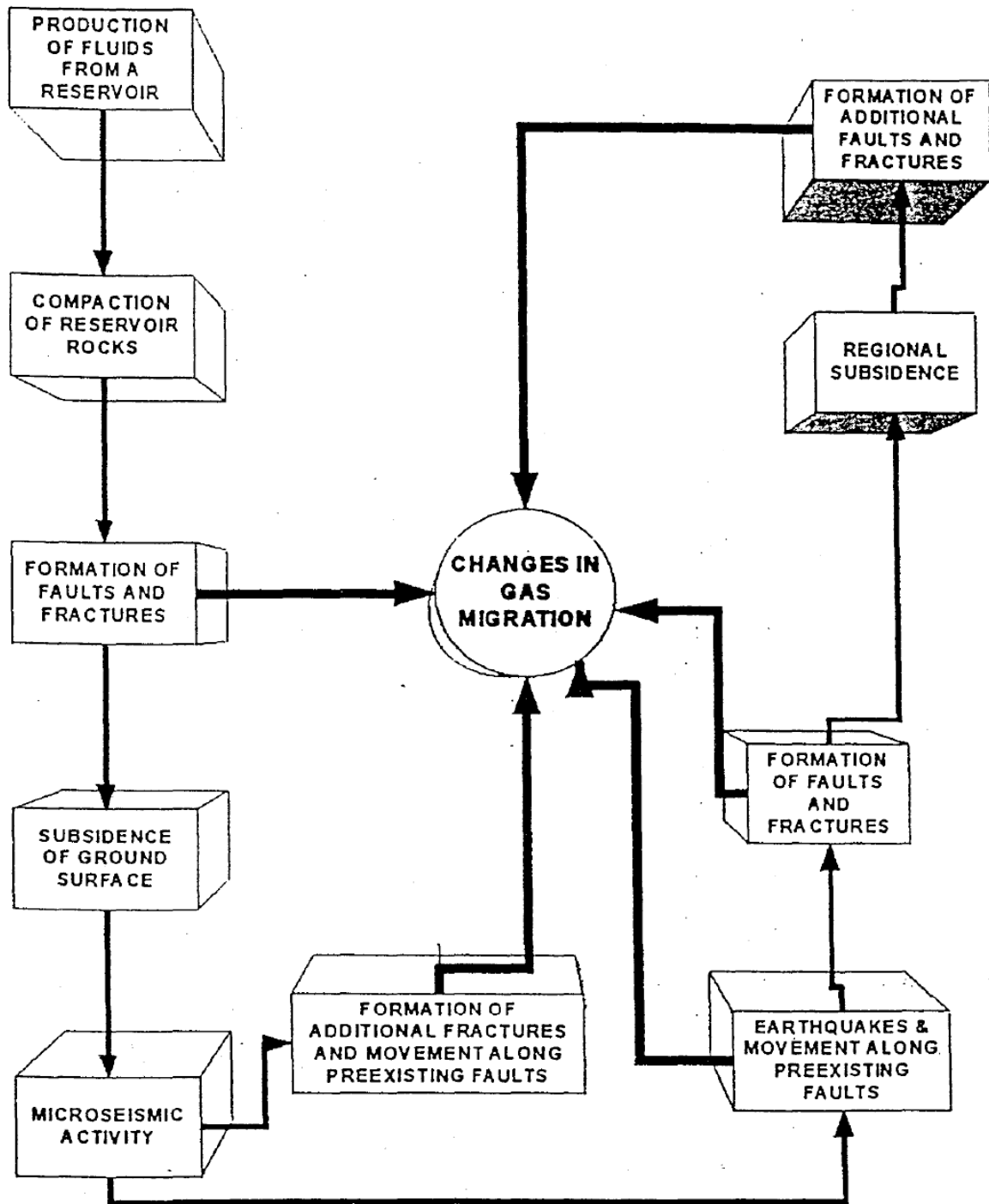

**FIGURE 2.** Schematic diagram of system relationships among the production of fluids, compaction, subsidence, and seismic activity.

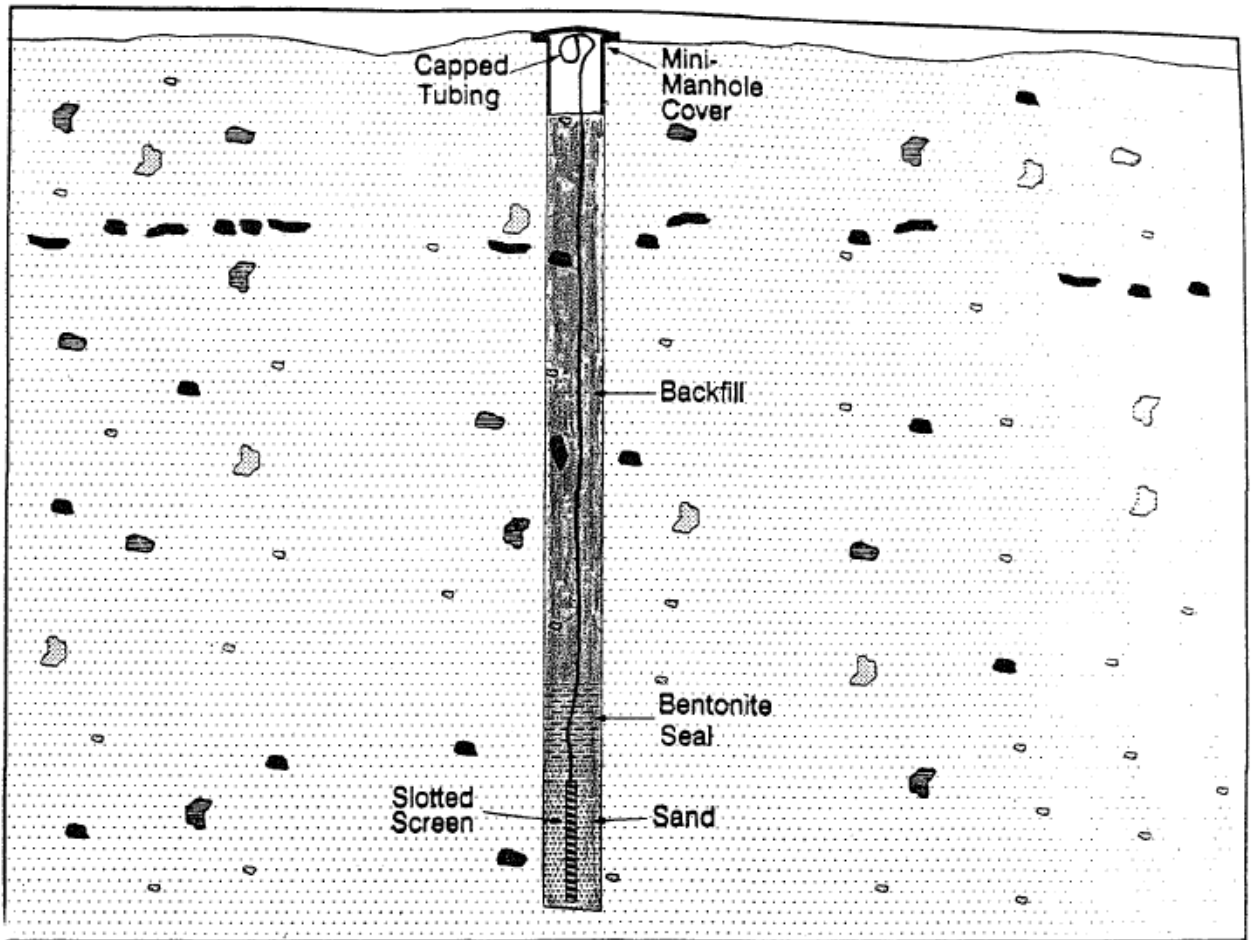

Monitoring probe for determining subsoil gas concentrations.

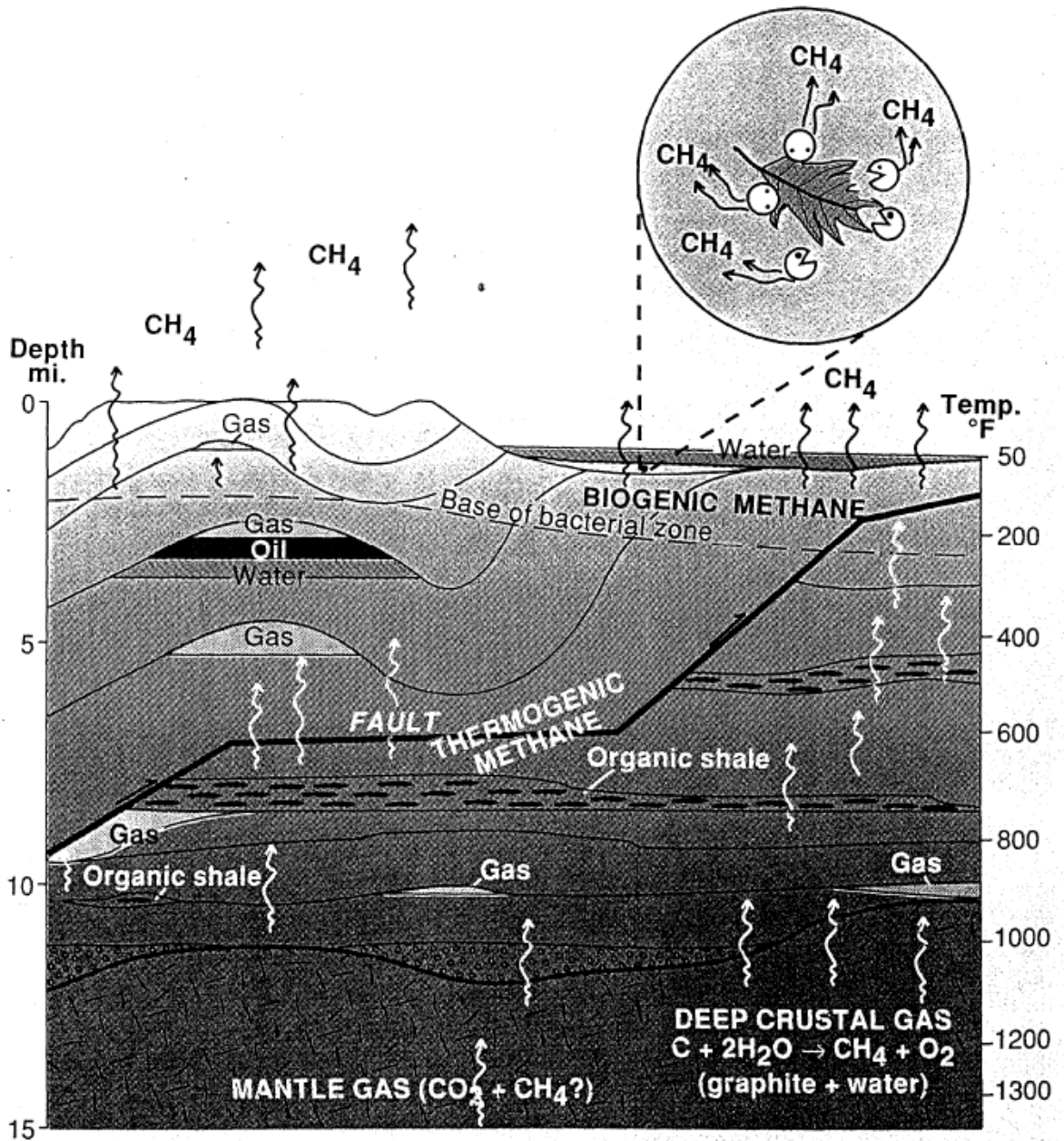
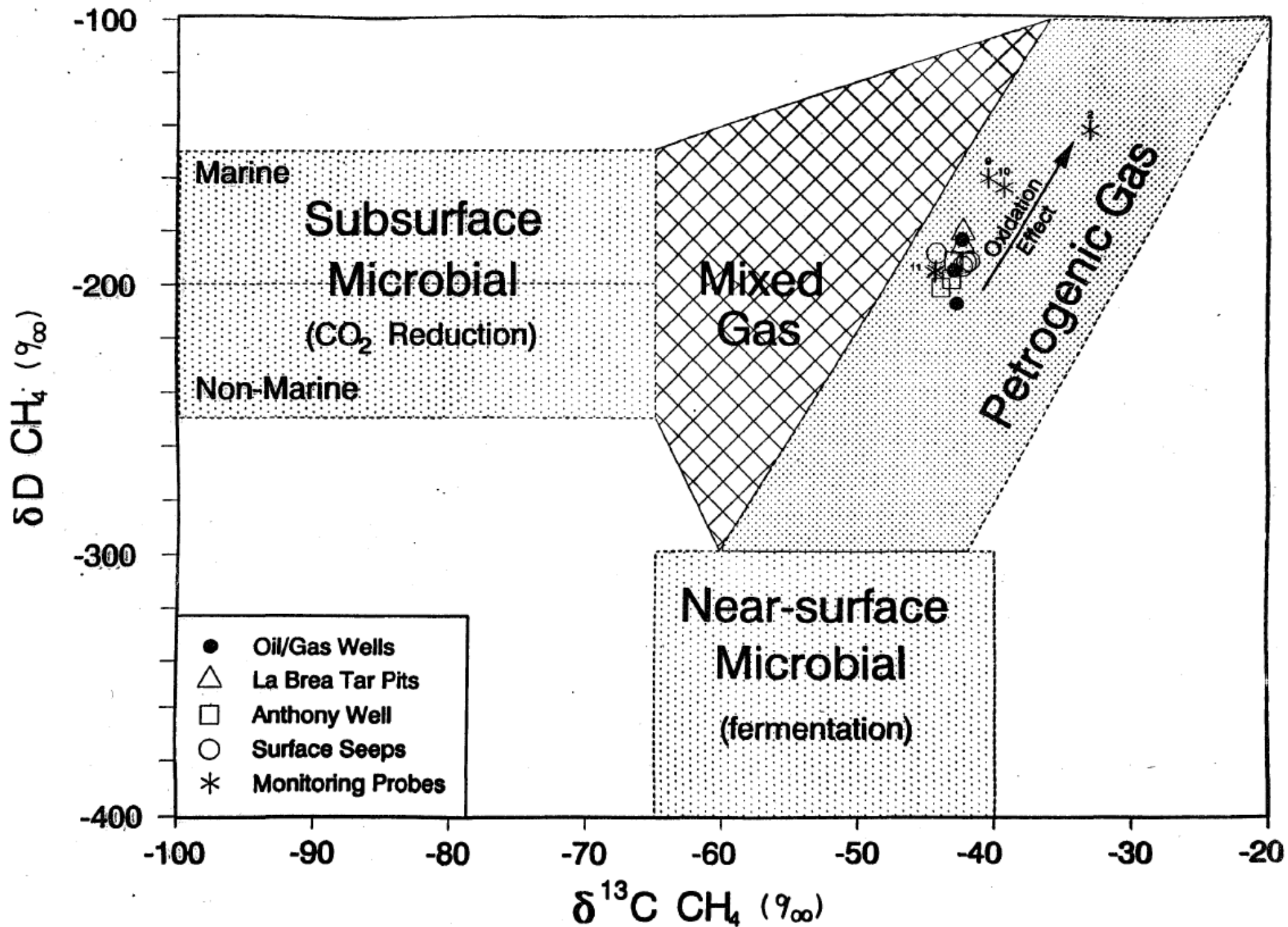

FIGURE 3.



BEFORE THE PUBLIC UTILITIES COMMISSION OF THE STATE OF CALIFORNIA

Rita Boppana,

Complainant,

vs.

Case 00-05-010  
(Filed May 11, 2000)

Southern California Gas Company,

Defendant.

And Related Matters.

Case 00-05-011  
(Filed May 11, 2000)  
Case 00-05-012  
(Filed May 11, 2000)

**THE PLAYA DEL REY GAS STORAGE FACILITY  
GAS MIGRATION HAZARDS; AND  
THE DUTIES IMPOSED TO MONITOR AND  
MITIGATE THESE DANGEROUS CONDITIONS**

March 24, 2007

By: **Patricia McPherson, President**  
**GRASSROOTS COALITION**  
11924 W. Washington Boulevard  
Los Angeles, CA 90066  
(310) 397-5779

TABLE OF CONTENTS

|                                                                                                                                                                                                                                                                                         | <u>PAGE</u> |
|-----------------------------------------------------------------------------------------------------------------------------------------------------------------------------------------------------------------------------------------------------------------------------------------|-------------|
| <b>I. <u>EXECUTIVE SUMMARY OF THE PLAYA DEL REY GAS STORAGE FACILITY GAS MIGRATION HAZARDS:</u></b>                                                                                                                                                                                     | <b>1</b>    |
| <b>A. FOR MANY YEARS SOCALGAS HAS KNOWN OF THE EXACT MANNER IN WHICH GAS LEAKS INTO THE NEAR-SURFACE SOILS, AQUIFERS AND INTO THE AIR AT PDR:</b>                                                                                                                                       | <b>1</b>    |
| <b>B. SOCALGAS DEVELOPED PROCEDURES FOR MONITORING AND COLLECTING LEAKING GASES, BUT <u>FAILED TO IMPLEMENT THESE PROCEDURES AT PDR:</u></b>                                                                                                                                            | <b>6</b>    |
| <b>C. SOCALGAS HAS CATEGORICALLY DENIED ANY VERTICAL GAS MIGRATION AT PDR, CLAIMING THAT THE FIELD ACTS AS A CLOSED CONTAINER, AND DENIES ANY RESPONSIBILITY FOR THE FOREGOING DESCRIBED CONDITIONS:</b>                                                                                | <b>12</b>   |
| <b>D. SOCALGAS HAS THE DUTY TO MONITOR AND PROTECT AGAINST THE GAS MIGRATION HAZARDS AT THE PDR FACILITY BECAUSE THEY UNDERTOOK TO OPERATE A GAS STORAGE FACILITY IN A PARTIALLY DEPLETED OILFIELD, CONTAINING MANY PREVIOUSLY DRILLED WELLS; CREATING A KNOWN DANGEROUS CONDITION:</b> | <b>15</b>   |
| <b>E. SOCALGAS IS RESPONSIBLE FOR THE LEAKING GAS CONDITIONS AT PLAYA DEL REY BECAUSE THEY EXERCISED <u>EXCLUSIVE CONTROL</u> OVER THE OLD OILWELLS, AND THE DANGEROUS CONDITIONS CREATED BY THEIR DETERIORATED CONDITIONS:</b>                                                         | <b>17</b>   |
| <b>II. <u>THE QUESTION BEING SUBMITTED TO THE COMMISSION, WHICH WAS "FRAMED" BY SOCALGAS, MAKES NO LOGICAL OR LEGAL SENSE IN THE CONTEXT OF THE TRUE FACTUAL ISSUES, AS SET FORTH ABOVE:</u></b>                                                                                        | <b>21</b>   |
| <b>A. THE LEGAL ARGUMENTS ADVANCED BY SOCALGAS ARE MISPLACED, AND LACK FOUNDATION:</b>                                                                                                                                                                                                  | <b>21</b>   |
| <b>B. SOCALGAS HAS MISUNDERSTOOD THE STANDARD OF CARE IMPOSED UPON THEIR UNDERGROUND GAS STORAGE OPERATIONS AT THE PDR FACILITY:</b>                                                                                                                                                    | <b>23</b>   |
| <b><u>CONCLUSIONS</u></b>                                                                                                                                                                                                                                                               | <b>25</b>   |

I. **EXECUTIVE SUMMARY OF THE PLAYA DEL REY GAS STORAGE FACILITY GAS MIGRATION HAZARDS:**

A. **FOR MANY YEARS SOCALGAS HAS KNOWN OF THE EXACT MANNER IN WHICH GAS LEAKS INTO THE NEAR-SURFACE SOILS, AQUIFERS AND INTO THE AIR AT PDR:**

In an engineering report prepared by Rick Lorio, Associate Petroleum Engineer of Underground Storage for Southern California Gas Company ("SOCALGAS"), the manner in which gas leaks to the surface at Playa Del Rey ("PDR") is described in detail (see Exhibit 1). This engineering analysis report was prepared, and is dated April 25, 1985. Extensive additional engineering reports and measurement data prepared by SOCALGAS reveal that large quantities of gas migrate upward into the surface casings of the old well bores at PDR. These surface casings were initially drilled and cemented to the rock formation at a typical depth of 700 feet below the surface. This is illustrated in the Exhibit 1 Attachments that diagram the well casings, and the paths of gas migration.

Effectively, the surface casings – and the annular volumes that exist between the main casing and the surface casings – serve as collection "containers" for the upward migrating gases, as illustrated in Exhibit 1. SOCALGAS has monitored the gas pressures and the gas composition in these surface casings continuously over many years. These data reveal the central defects existing in the old well bores, in allowing gas to migrate into the near-surface soils and aquifers.

Exhibit 1 identifies these defects, and describes what mitigation measures need to be taken. In summary, these are described in the report as follows (emphasis added):

Problem:

All wells have some uncemented segments. Few wells have any cement above 2000. Formation sloughing may have filled in some of these wellbores but most remain the most permeable upward path for gas migration.



Solution:

Noise and TDT monitor active wells to find areas of increasing activity. Continually produce shallow zones. Vent to atmosphere all gas coming from surface casing shoe aquifer.

This description is provided in Exhibit 1 under the caption "Uncemented Wellbore Leaks: Type 3." Under the caption "Casing Shoe Leaks: Type 2," the following is described:

Problem:

Casing shoe leaks due to poor, deteriorated cement or to leakage through wso holes in active or abandoned wells.

Solution, Abandoned Wells:

Collect all free gas from overlying zones. Repair work not possible.

In summary, the "Solutions" set forth above by SOCALGAS include:

1. "Continually produce shallow zones."
2. "Collect all free gas from overlying zones."

Under the caption "Abandonment Plug Leaks: Type 4," two types of abandonment are described:

Problem, Type A Abandonment:

Cement plugs inside casing allow some gas to migrate upwards. Because its casing was cut off below the surface string, water will continue to fill casing as gas leaks out. Leak will therefore be sporadic and low rate.

Problem, Type B Abandonment:

Cement plugs inside casing allow some gas to migrate upwards. Because the casing stub is cut off within 100' of surface, the entire surface casing fills with gas. No liquid enters the well. The gas leak unloads fluid from the well and the rate increases with time. Eventually all of the fluid unloads and the leak rate stabilizes at a near constant daily rate.

Problems, Both Type Abandonments:

1. Casing cap, surface casing and casing shoe cement competent. Gas will build up inside-surface casing and force its way into shallow aquifer sand. Gas will surface at a non-leaking well that has the following problems.
2. Casing cap not competent. Gas will surface near well.
3. Surface casing or shoe cement not competent. Gas will spread over large area as it rises to surface lethargically.

Solution, Problem 1:

Direct repair of leaking well not possible because source well is unknown. Other wells where gas appears are continually vented to surface.

Solution, Problem 2:

Unearth well and recap or place collection funnel over it. Rig work not required. Vent all gas to atmosphere.

Solution, Problem 3:

Unearth well, move in rig, attempt to enter and repair old casing. Produce gas through casing into low pressure system. Vent surface annulus to atmosphere.

In summary, the "Problems" and "Solutions" identified under the caption "Abandonment Plug Leaks: Type 4" reveal the true nature of how the abandoned wells at PDR cause the near-surface aquifers to be continually recharged with the leaking gas:

1. “Gas will build up inside surface casing and force its way into shallow aquifer sand.”
2. “. . . the [leak] rate increases with time . . . and the leak rate stabilizes at a near constant daily rate.”
3. “Gas will spread over large area as it rises to the surface lethargically.”

The central issue addressed by SOCALGAS in the above topic is the manner in which “gas will surface at a non-leaking well.” This issue was addressed, and corroborated the above finds, in a report prepared by Babson and Sheppard, petroleum engineers, dated July 23, 1985. Their findings included the following (emphasis added):

1. “Leakage of natural gas from underground gas storage reservoirs is not unusual.”
2. “The sustained high pressures at which such projects frequently operate tend to develop pockets or channels of gas saturation which are outside the confines of the normal storage reservoir.”
3. “The Storage Reservoir is particularly susceptible to occurrences of this nature because of the large number of oil wells drilled into the field’s reservoirs prior to initiation of the storage operations.” [Exhibit 2 is attached herein to identify the oil wells that were drilled into the PDR Storage Reservoir prior to initiation of the storage operations.]
4. “Each of those wellbores provides a potential channel for the uncontrolled migration of fluid.”

5. “Gas could migrate from the storage reservoir through one wellbore to an upper formation, then through a second wellbore to yet higher formation.”

6. “Such upward flows could be expected to occur naturally over time even without the presence of the storage operation.”
7. “Gas remaining in depleted, abandoned reservoirs will naturally tend to seek a route to a site of lower-pressure – a shallower formation.”
8. “It could even be driven toward the available flow channels by the entry of edgewater into the reservoir seeking to replace the depleted hydrocarbon saturation.”

9. “The Gas Company’s storage project tends to emphasize this potential for upward migration because of the high pressures necessary for its operation.”

SOCALGAS has long recognized these problems at PDR, including by way of entering into contractual agreements that purport to allow “storage” of their gas as close to the surface as 500 feet. Namely, quoting from the SOCALGAS report described above:

- “Gas will build up inside surface casing and force its way into shallow aquifer sand.”
- “Gas will spread over large area as it rises to surface lethargically.”

The corresponding language in contractual legal documents filed with the Los Angeles County Records Office by SOCALGAS typically reads as follows:

- FOR A VALUABLE CONSIDERATION, receipt of which is hereby acknowledged, HUGHES TOOL COMPANY, a corporation organized under the laws of the State of Delaware, hereby conveys to SOUTHERN CALIFORNIA GAS COMPANY, a corporation, the exclusive right to use subsurface mineral, oil and/or gas zones for injecting, storing and withdrawing natural gas (whether produced from such or other property) therein and therefrom and for repressuring the same; but with no right to use the surface or to carry on such operation except between a depth of -500 feet to -7000 feet from the surface thereof in the following described property:

- Hughes Tool Company hereby covenants and agrees to prohibit exploration for mineral, oil, gas or other hydrocarbons between depths of -500 feet to -7000 feet from the surface of the above described property.

Clearly, the “exclusive right to use subsurface mineral, oil and/or gas zones for injecting, storing and withdrawing natural gas (whether produced from such or other property) therein and therefrom and for repressuring the same,” would be inclusive of the shallower migration zones described in the Babson and Sheppard report quoted above.

Furthermore, the geographic extent of the property [viz., “the following described property:”], as described in the documents recorded with the County Recorder’s Office, establish the true boundaries over which SOCALGAS has direct legal responsibility regarding gas leaking to the surface. These boundaries need to be carefully identified regarding the legal issues that are to be addressed regarding this proceeding.

In summary, the legal analysis regarding SOCALGAS responsibilities relating to the leaking gases at PDR must consider the above foundational material critical in this determination. The above factual foundation is essential in establishing the true nature of the legal undertaking of SOCALGAS in operating an underground gas storage field in a partially depleted oilfield under high pressure, where a large number of oil wells were drilled into the field’s reservoirs prior to initiation of the storage operation. The controlling legal issues regarding this undertaking will be discussed below.

**B. SOCALGAS DEVELOPED PROCEDURES FOR MONITORING AND COLLECTING LEAKING GASES, BUT FAILED TO IMPLEMENT THESE PROCEDURES AT PDR:**

In a document prepared by SOCALGAS titled, “Gas Inventory Monitoring, Verification, and Reporting Procedures,” (see Exhibit 3), the following procedures are

described for the monitoring and collection of the leaking gases, as detailed in the Rick Lorio report titled, "The Playa Del Rey Monitoring Program," (see Exhibit 1), under the caption Non-Storage Zone Wells, at page 5 of 18, the following is described (emphasis added):

Non-storage zone wells monitored include both Company wells and wells owned by others in overlying and underlying zones and in other fields within two miles of the storage reservoir boundary, where applicable. These wells are categorized as follows:

- i. Pressure observation wells are located in overlying and underlying permeable formations, or adjacent to the storage reservoir but across assumed confining boundaries, such as faults, permeability pinchouts, below the gas-liquid contact or beyond the spill point of the storage zone's confining structure. Although normally static, these wells may have artificial lift mechanisms for removal of gas and fluids.
- ii. Gas collection wells are located where known gas migration from the storage zone is intercepted and collected. These wells are normally equipped with operating artificial lift mechanisms so that both liquids and gas can be produced, causing a pressure sink in the reservoir near the wellbore.
- iii. In some fields, shallow water observation wells have been drilled into aquifer zones existing in the first permeable sand above the shoe of the surface casing. These wells are closed in at the surface and gas concentrations in the wellbore are measured weekly.

It is important to recognize that Rick Lorio addressed these same issues with the following relevant language (see previous discussion herein) (emphasis added):

- "Gas will build up inside surface casing and force its way into shallow aquifer sand."

Clearly, the monitoring and collection procedures highlighted above are critical in dealing with shoe leaks occurring at the bottom of the surface casing, located at a typical depth of 700 feet, as illustrated in Exhibit 1. Succinctly, these procedures are described as follows (emphasis added):

“... shallow water observation wells have been drilled into aquifer zones existing in the first permeable sand above the shoe of the surface casing.”

At PDR there are permeable sands extending to a depth of at least 500 feet.

Accordingly, it is critical that the cement shoes on the active and abandoned wells at PDR be evaluated for integrity using the shallow water observation wells design procedure developed by SOCALGAS. In particular, Rick Lorio of SOCALGAS, in Exhibit 1, warns that if the surface casing or shoe cement is not competent “gas will spread over large area as it rises to surface lethargically.”

More importantly, is the high pressure gas that has been extensively measured by third parties in the “50 Foot Gravel,” which is a shallow sand and gravel aquifer that overlies the legal boundaries that SOCALGAS claims to have the contractual legal authority to store gas as close to the surface as 500 feet. However, SOCALGAS has consistently denied any legal responsibility over this pressurized gas, and has failed to monitor or collect these gases at PDR in their efforts to shirk their responsibility for the leaking gases.

In a document prepared by the Consumer Protection and Safety Division of the California Public Utilities Commission, dated August 20, 2002 and revised on November 18, 2004 titled, “Complaint Case Facts and Findings (Playa Del Rey Storage Field)” the following facts and findings were set forth:

- Three Types of Natural Gas in PDR:  
“There is evidence of surface detection of three types of natural gas in PDR, namely: Biogenic gas, Native PDR Thermogenic gas and Storage Reservoir Thermogenic gas.”
- 133 PPM Helium from Bar-Hole Samples near Big Ben Well:

“SoCalGas internal office memorandum, dated November 20, 1991 revealed that gas samples collected from bar-holes around Big Ben Well contained 30,000 PPM to 620,000 PPM natural gas and these samples contained 133 PPM to 188 PPM Helium. A close examination of the memo revealed that three samples were collected on 1/11/91, at bar-holes #12, 13 & 14. Isotopic analysis of these samples indicated with high probability the signature of Storage Reservoir gas (meaning that the gas migrated from Storage Reservoir). In addition, the memo did not indicate any more sampling at these bar-holes or subsequent remedial action. On 8/23/91 and subsequent dates, samples were collected from bar-hole H instead of bar-holes 12, 13 & 14. The isotopic analyses of the new samples did not reveal the storage gas signature and subsequent discussion on the memo ignored the initial sample data, its significance and if there was any remedial action.”

- 22 PPM Helium from a Shallow Probe Sample by John Sepich and Associates:

“Isotech Laboratory performed an isotopic analysis of a gas sample submitted by Sepich & Associates on 3/25/99. Sepich and Associates was working for Playa Vista developers (developers of residential and business properties around the PDR Storage field. The isotopic analysis report indicates the gas sample was collected from Playa Vista Project Area-D. The analysis report also revealed presence of Ethane and 22 PPM Helium in the gas sample. The significance of this isotopic analysis report is the presence Storage Reservoir gas or Native PDR gas signature and the location where the gas sample was collected (Area-D of Playa Vista Project). My opinion is that the probability of Storage Reservoir gas sample from PDR area containing Ethane and 22 PPM Helium is greater than 50 percent (>50%). Furthermore, the location where the sample was collected should be of major concern” (emphasis added).

- 100 PPM-1000 PPM Helium from Groundwater Samples Collected and Analyzed by Exploration Technologies, Inc. (ETI):

“City of Los Angeles Building and Safety Department retained ETI to conduct test, analyze and provide advice on Playa Vista project. Groundwater samples were



collected in 2000 from Playa Vista Project Area, and dissolved gases were extracted and analyzed by ETI in addition to other scientific sampling and testing. Several groundwater samples revealed presence of high Helium concentrations and Methane dissolved in the groundwater. The origin of this Helium in the groundwater is not clear. However, some people have postulated that the groundwater absorbs or strips the Helium from the Storage Reservoir gas or Native PDR gas as it migrates through the aquifer to the ground surface. Hence, Thermogenic gas is detected in soil-gas without Helium. Although this postulation seems plausible, I have not seen any scientific paper on this absorption theory and the kinetics.”

- Dr. Victor Jones of ETI detected Thermogenic gas components at the Surface and detected H<sub>2</sub>S in Soil Gas during his investigation in 2000:

“ETI conducted an extensive soil gas investigation in Playa Vista area for the City of Los Angeles in 2000. The isotopic analysis report of the samples collected revealed presence of Methane, Ethane, Helium, H<sub>2</sub>S, Toluene and other volatile organic compounds (voc). The presence of numerous Thermogenic gas components in the shallow soil gas samples analyzed indicates a deeper source for this gas.”

- Previous Reservoir Inventory Verification Analysis by SCG indicated gas migration loss (8/22/80):

“A Reservoir Inventory Verification Analysis conducted by Theodoros Georgakopoulos on August 22, 1980 for SoCalGas indicated gas migration loss. The migration pathways to the Townsite area (separate geologic zone) is unknown. The report estimated storage reservoir gas loss between January 1961 and December 1979 to be 0.10 B.c.f. Subsequent reports estimated the gas loss to have decreased.”

- Presence of Methane gas around Troxel Well:

“As part of Energy Division (ED) initial preliminary investigation, ED retained MHA, who subcontracted Giroux & Associates to conduct site investigations at the Troxel and Lor Mar well site locations in 2001. These recent studies found very high methane concentrations

(greater than 50,000 ppm) at the Troxel site and low methane concentrations (1 to 6 ppm) at the Lor Mar site” (emphasis added).

Investigation reports, including reports prepared on behalf of SOCALGAS, reveal the common occurrence of gas leaking to the surface at the location of the surface casing. Namely, leaking from the annular space, and volume, existing between the surface casing and the primary oilwell casing. This is especially true for the many abandoned wells that were found to be leaking gas to the surface, and required reabandonment. These include wells Troxel, Townsite 2, Block 11 and others. This would reveal the urgent need to carefully evaluate the shoe leak and cement conditions at each of the abandoned wells within the PDR field, using the procedures previously described herein, as developed by SOCALGAS.

Regarding operational wells, SOCALGAS has been monitoring the surface casing volumes for gas pressures, rate of pressure build-up, gas constituents – including Helium, and other leakage conditions for many years. These data are very important regarding identifying the manner in which gas is migrating up the wellbores, and entering the aquifer zones at the shoe leak locations.

The above report by the Consumer Protection and Safety Division of the PUC has not included these important field measurement data gathered by SOCALGAS over many years. It is important to note that these data, including Helium counts, have been used by SOCALGAS to determine the extent of storage gas leakage into the geologically connected permeable reservoirs that surround the PDR “primary” gas storage area.

This migration of storage gas into the surrounding geologically connected reservoirs has been continuously ongoing since the primary storage reservoir pressure was raised above 750 pounds per square inch, beginning in the early 1940’s. This storage gas has commingled with

the billions of cubic feet of native gas that has existed within PDR oilfield, before its conversion to an underground storage facility.

For the foregoing reasons, the gas samples that have been collected from the oilwell surface casings, from surface seeps, and from dissolved and free gases in the 50 Foot Gravel zone, contain a mixture of storage gas (including Helium), Native gas, and Carcinogens that are carried to the surface by the upward migrating gases.

It is important to note that the surface casings, and the gas pressure build-up therein are routinely vented to the atmosphere in accordance with the "Solutions" recommended by Rick Lorio, in the report discussed above. Namely these included (emphasis added):

“Vent to atmosphere all gas coming from surface casing shoe aquifer,”

Accordingly, this intentional venting of gas to the atmosphere – in which the gas has been confirmed to contain carcinogens – is of great concern. Many of these wells are located in close proximity to homes and apartments in the PDR area, and such venting presents a serious health hazard.

**C. SOCALGAS HAS CATEGORICALLY DENIED ANY VERTICAL GAS MIGRATION AT PDR, CLAIMING THAT THE FIELD ACTS AS A CLOSED CONTAINER, AND DENIES ANY RESPONSIBILITY FOR THE FOREGOING DESCRIBED CONDITIONS:**

The first attempt that SOCALGAS made to deny responsibility was to hire Dr. Kaplan, a geochemist, to evaluate the surface gas seeps for chemical composition. His results in the 1992 and 1993 time period were proclaimed by SOCALGAS, including in the newspapers, to prove that the surface gas seeps at PDR were biogenic gas (commonly described as swamp

gas). These findings were later totally discredited by the soil gas investigations carried out by Exploration Technologies, Inc. (ETI) of Houston, Texas on behalf of the City of Los Angeles.

As summarized above by the Consumer Protection and Safety Division, of the California Public Utilities Commission, the surface seeps were determined to be thermogenic in gas composition, and originating from a deep source (viz., not swamp gas). Furthermore, the so-called John Sepich probe – that extended to a depth of 20 feet, for the first time – revealed significant levels of helium in the seeping gases (viz., 22 ppm helium from his 20-foot deep soil gas probe).

A much more detailed analysis of the seeping gases was performed by Victor Jones of ETI, in which his findings are summarized above in the identified Consumer Protection and Safety Division report. His gas samples were collected using, for the first time, much deeper soil gas probes that extended into the “50 Foot Gravel,” with samples collected from depths exceeding 50 feet.

Water samples were also collected from these much deeper sampling depths, and analyzed for the dissolved gas chemical compositions. These samples further confirmed the thermogenic character of the seeping gases, in that they contained methane, ethane, helium, H<sub>2</sub>S, toluene (a carcinogen) and other volatile organic compounds (VOC's) consisting of propane, butane and xylenes. These gases are especially characteristic of thermogenic oilfield gas. These compositions are also typical of those gases leaking from the abandoned wellheads, that have required reabandonment throughout the PDR field.

Most noteworthy of the deep soil gas samples (viz., below 50 feet) collected by Victor Jones of ETI were the very high helium count levels of between 100 ppm and 1000 ppm, as reported in the Consumer Protection and Safety Division.

A further attempt was made by SOCALGAS to conceal the true dangers of the leaking abandoned wells by claiming that the wellhead leaks were biogenic gas, and not having anything to do with their storage operations. However, the true chemical analysis of the leaking cases contained methane, ethane, propane, butane and other higher order hydrocarbons, entirely consistent with thermogenic gas, that was leaking from a deep source.

Furthermore, senior technical personnel from SOCALGAS have proclaimed before City of Los Angeles hearings on the PDR field, that there is no vertical gas migration out of the field, and the storage reservoir acts as a closed container. It is important to note that the PDR facility operates under a Conditional Use Permit (“CUP”) issued by the City of Los Angeles. An important condition of this CUP is as follows:

“That the underground gas pressure shall be kept sufficiently low so that there will be no escape of gases into the air above the ground.”

All of the above described factual issues relate directly to the “Scoping Memo” dated March 7, 2005 which stated the issues that are in controversy regarding the subject adversary proceeding:

“If the SoCalGas Playa Del Rey gas storage facility is venting or leaking gas or depositing carcinogens into the air or soil to the detriment of the health or safety of the neighboring community” (emphasis added).

The above factual framework is essential in identifying the legal duties imposed upon SOCALGAS as a consequence of undertaking a gas storage operation in the partially depleted oilfield of Playa Del Rey.

**D. SOCALGAS HAS THE DUTY TO MONITOR AND PROTECT AGAINST THE GAS MIGRATION HAZARDS AT THE PDR FACILITY BECAUSE THEY UNDERTOOK TO OPERATE A GAS STORAGE FACILITY IN A PARTIALLY DEPLETED OILFIELD, CONTAINING MANY PREVIOUSLY DRILLED WELLS; CREATING A KNOWN DANGEROUS CONDITION:**

The controlling principle of law imposed upon SOCALGAS regarding the PDR facility is set forth in Restatement Second of Torts Section 321:

§321. Duty to Act When Prior Conduct is Found to be Dangerous

- (1) If the actor does an act, and subsequently realizes or should realize that it has created an unreasonable risk of causing physical harm to another, he is under a duty to exercise reasonable care to prevent the risk from taking effect.
- (2) The rule stated in Subsection (1) applies even though at the time of the act the actor has no reason to believe that it will involve such a risk.

Within the meaning of “actor” regarding the PDR facility would be the “act” of undertaking a gas storage operation in the partially depleted Playa Del Rey oilfield by SOCALGAS.

SOCALGAS subsequently realized, or should have realized, that the many old oilwells drilled into Playa Del Rey oilfield – before they began their operations – would serve as conduits for both storage gas and native oilfield gas to escape and migrate to the surface.

There was a duty imposed to exercise reasonable care to prevent the risk from taking effect. In fact, SOCALGAS developed written policies and procedures (viz., as described above) to monitor and mitigate against the risks created by the upward migration of gases into shallow zones. However, these policies and procedures were not implemented at the PDR

facility. They are believed to have been implemented at other underground gas storage facilities operated by SOCALGAS, at least in part.

Accordingly, the appropriate standard of care to be employed at the PDR facility is established by these written policies and procedures. In summary, these include:

1. Monitoring of both Company wells and wells owned by others in overlying and underlying zones and in other fields within two miles of the storage reservoir boundary.
2. Drill shallow water observation wells into the aquifer zones existing in the permeable sand zones above the shoe of the surface casing.
3. Locate pressure observation wells in overlying and underlying permeable formations, or adjacent to the boundaries, such as faults, permeability pinchouts, below the gas-liquid contact or beyond the spill point of the storage zone's confining structure.
4. Install artificial lift mechanisms for removal of gas and fluids, within the above described offending areas.

For the foregoing reasons, it is essential to establish the legal boundaries of the true extent of the storage reservoir. SOCALGAS claims to have storage rights provided presumably by the relevant documents on file with the Los Angeles County Recorder's Office. These documents need to be carefully identified, primarily to establish the true "legal" boundaries of the PDR facility.

The established boundaries of the PDR facility would then allow determining the monitoring program needed within "two miles of the storage reservoir boundary," as described in paragraph (1) above.

In summary, the PDR facility must conform to an appropriate standard of care, commensurate with the extreme hazards posed by storing billions of cubic feet of flammable and explosive gas under a highly urbanized residential community. This extreme hazard is exacerbated by the hundreds of old oilwells that were drilled into the Playa Del Rey oilfield, many years before the gas storage operations began, thereby severely compromising the rock formations sealing capacity.

Furthermore, it is a well known characteristic of all gas storage fields that the gas leakage losses are directly proportional to the reservoir pressure. The Babson and Sheppard Report, discussed above, identified this hazard in the following way:

“The Gas Company’s storage project tends to emphasize this potential for upward migration because of the high pressures necessary for its operation.”

SOCALGAS studies have confirmed that the primary storage area of the PDR field begins to leak when the reservoir is pressurized above 750 pounds per square inch. In contrast, the primary storage reservoir pressure frequently reaches 1700 pounds per square inch, more than double the pressure that precipitates the gas leakage

**E. SOCALGAS IS RESPONSIBLE FOR THE LEAKING GAS CONDITIONS AT PLAYA DEL REY BECAUSE THEY EXERCISED EXCLUSIVE CONTROL OVER THE OLD OILWELLS, AND THE DANGEROUS CONDITIONS CREATED BY THEIR DETERIORATED CONDITIONS:**

SOCALGAS acquired exclusive control over hundreds of old oilwells that had been drilled, and many of them abandoned, prior to SOCALGAS undertaking gas storage operations



in the PDR field. As previously discussed, the Rick Lorio Report itemized the central defects in these old wells, including:

1. All wells have some uncemented segments. Few wells have any cement above 2000 feet. . . . but most remain the most permeable upward path for gas migration.
2. Casing shoe leaks due to poor deteriorated cement or to leakage through water shut-off holes in active or abandoned wells.
3. Surface casing and surface casing shoe cement (viz., at a typical depth of 700 feet) are not competent. Gas will build up inside surface casing and force its way into shallow aquifer sand.
4. Gas will surface at a non-leaking well, including at wells where the surface casing or shoe cement is not competent. Gas will spread over large area as it rises to surface lethargically.

Surface casing leaks, especially in old abandoned wells, have been documented repeatedly at PDR over many years. The issues raised in paragraph 4, above, are especially important regarding the degree of care and soil gas monitoring necessary to identify which of the old wells are truly leaking. Namely, gas will surface at a non-leaking well. Accordingly, even if the well is reabandoned at the location where the gas is surfacing, this will not cure the leaking well problems.

This problem is especially serious at PDR because of the very extensive sand and gravel permeable zone that was laid down over geologic time by the original river channel flow of the Los Angeles River. This shallow, highly permeable zone, is commonly known as the "50 Foot Gravel." However, other permeable zones exist extending to a depth of approximately 600 feet.

In fact, the surface casing depth requirements (viz., typically 700 feet) are dictated by State of California law, mandating that the surface casing be protective of the fresh water zones

overlying the oilfield. Namely, the very conditions described in the Rick Lorio Report identify violations of State Law:

“Gas will build up inside surface casing and force its way into shallow aquifer sand.”

In short, the sealing integrity of the old surface casings, especially including the cement shoe at a typical depth of 700 feet, is pivotal regarding the operations and maintenance of the PDR field.

Historical drilling records reveal serious problems with achieving a competent cement seal when the surface casing was being cemented to the surrounding rock formation. This was especially serious for the Townlot Wells that were closer to the Pacific Ocean beach. The drill hole would often collapse during the drilling operation, preventing a proper cement squeeze at the shoe location of the surface casing.

Furthermore, saltwater intrusion from the nearby Pacific Ocean is also highly corrosive to the steel surface casing, and is known to cause significant deterioration of the concrete shoe materials.

These wells were drilled in the 1920's and 1930's, as identified herein in Exhibit 2. Certainly, when they were drilled in this early time period, there was no contemplation that the oilfield would ever be used for storing high pressure. The technology for storing natural gas in a partially depleted oilfield had not yet been invented in the 1920's/1930's. Also, the technology for performing well completions and cementing operations were still within their infancy.

The history of the oilwell acquisitions by SOCALGAS at PDR were largely dictated by the large volumes of storage gas that were leaking out of the primary storage area. Once the

storage pressure was raised above 750 pounds per square inch, storage gas began leaking into oilwells operated by Union Oil Company. Initially, Union Oil Company and SOCALGAS entered into an agreement regarding how much SOCALGAS would pay Union Oil Company for the return of the lost gas, plus any additional native gas produced by Union Oil from their wells. Eventually, all right title and interest to these wells were conveyed to SOCALGAS, with legal title conveyed pursuant to documents on file with the Los Angeles County Recorder's Office.

It was also discovered by SOCALGAS that storage gas was leaking into the area known as the Townlot Wells, and migrating as far north as the Troxel well location. For this reason, SOCALGAS acquired all legal interests to these wells, as documented in records on file with the Los Angeles County Recorder's Office.

For the foregoing reasons, SOCALGAS has a direct legal ownership interest in these wells. The mere abandonment of these wells does not extinguish the responsibility of SOCALGAS over the proper monitoring and the maintaining of these wells in a safe condition.

The basic public policy of California is that every person is responsible for an injury, to property or person, caused by his or her lack of ordinary care or skill in the management of his or her property. See Civil Code Section 1714(a), and the numerous Appellate and Supreme Court decisions that have interpreted its application to ownership interests, such as are involved herein.

It is important to recognize that the surface casings of the abandoned wells extend into the surface rights area located above 500 feet. Rick Lorio points out in his report, as discussed above, the gas migration hazards created by this condition:

1. Because the casing stub is cut off within 100 feet of the surface, the entire surface casing fills with gas.

2. The gas leak unloads fluid from the well and the rate increases with time.
3. Eventually all of the fluid unloads and the leak rate stabilizes at a near constant daily rate.

These facts establish that there is an ongoing trespass to the surface property ownership interests, especially since the gas is leaking at a depth of approximately 100 feet. Furthermore, as described by Rick Lorio, the gas will spread over large areas as it rises to the surface lethargically. Accordingly, there are violations of trespass laws on adjoining surface properties as well.

These violations would also constitute nuisance because of the explosive and carcinogenic character of the migrating gases.

The Public Utility Code mandates by statute that all utility property be maintained in a safe condition. Accordingly, the legal ownership of the above-described wells by SOCALGAS imposes an obligation upon them to properly monitor and mitigate the hazards associated with these wells, as described above.

Furthermore, there is a need to provide proper warning to the surface owners regarding the need to take preventative measures to protect themselves and their property from the above-described leaking gases.

**II. THE QUESTION BEING SUBMITTED TO THE COMMISSION, WHICH WAS “FRAMED” BY SOCALGAS, MAKES NO LOGICAL OR LEGAL SENSE IN THE CONTEXT OF THE TRUE FACTUAL ISSUES, AS SET FORTH ABOVE:**

**A. THE LEGAL ARGUMENTS ADVANCED BY SOCALGAS ARE MISPLACED, AND LACK FOUNDATION:**

The specific question that has been “framed” by SOCALGAS, and not agreed to in that context by Grassroots Coalition, for submittal to the Commission by briefs is as follows:

“Does SOCALGAS have responsibility for any non? storage and non? pipeline gas that migrates through an area where SOCALGAS owns the mineral rights but does not use SOCALGAS? active or abandoned wells as a conduit to migrate to the surface or from one underground reservoir or zone to another?”

Even if any scientific or legal sense can be made of this convoluted description, it still is objectionable because it lacks foundation regarding the issues relevant to this adversary proceeding.

As previously stated, the “Scoping Memo” identifies the relevant issues as follows:

“If the SoCalGas Playa Del Rey gas storage facility is venting or leaking gas or depositing carcinogens into the air or soil to the detriment of the health or safety of the neighboring community” (emphasis added).

Section I. of this report has addressed the factual foundation upon which this Scoping Memo addresses. The question posed above, as framed by SOCALGAS, goes far afield of this Scoping Memo by creating its own technical jargon.

First of all, it is not possible to scientifically define the term “non storage gas,” and SOCALGAS has made no attempt to define this term. Fundamentally, when the natural gas is injected into the partially depleted PDR oilfield by SOCALGAS under extremely high pressures, this gas commingles with the native oilfield gases existing in the reservoir. Furthermore, these high-pressure conditions cause the commingled gases to migrate into numerous geologically connected oilfield reservoirs that contain even larger quantities of native gases. This multiple commingling constitutes the gases that become available to migrate up the old well bores and faults, as described in the SOCALGAS Rick Lorio report detailed above. This would also be the nature of the venting or leaking gases set forth in the Scoping Memo.

Secondly, even if there were so-called “non storage” and/or “non pipeline” gas migrating through the mineral rights territory of SOCALGAS, this gas would become commingled with the storage gas and the native gases, already commingled in mineral rights territories of SOCALGAS. In short, once the hypothetical gas migration occurred, it would automatically lose whatever unique identity it was presumed to have.

SOCALGAS has failed to give any clue as to how this identity is to be carried out scientifically.

Thirdly, the issue as framed by SOCALGAS, expressly excludes a determination by the Commission of responsibility for gas that migrates and uses SOCALGAS active or abandoned wells. As set forth in Part I. of this report, the central gas migration hazards at the PDR facility are the active or abandoned wells serving as conduits for the commingled gases to reach the surface, and into the near-surface permeable zones, including freshwater aquifers.

Accordingly, any determination of the responsibility issues, as framed by SOCALGAS, would be meaningless within the context of the Scoping Memo.

**B. SOCALGAS HAS MISUNDERSTOOD THE STANDARD OF CARE IMPOSED UPON THEIR UNDERGROUND GAS STORAGE OPERATIONS AT THE PDR FACILITY:**

The fundamental premise of responsibilities imposed by negligence law, is the duty to act reasonably under the circumstances. This is established by determining the standard of care required. Conduct falling below this standard of care, can be found to be negligent conduct. The appropriate responsibilities, under the instant set of facts, are established by this standard of care.

Accordingly, it is meaningless herein to focus upon the single issue of mineral rights and/or storage. Although these become one aspect of the overall issues, they, in themselves,

misdirect attention away from the central issues identified in the Scoping Memo. The totality of contractual documents, and their specific languages need to be evaluated.

The Conditional Use Permit issued by the City of Los Angeles, and the contractual obligations imposed upon SOCALGAS regarding the prohibition of operating the gas storage facility at pressures that would cause gases to leak into the air, must be considered in establishing SOCALGAS responsibilities.

Various California Administrative Codes prohibit the leakage of gas from surface casings into adjoining permeable aquifers, and must be considered in determining SOCALGAS responsibilities. Violations of the Regulations could be deemed negligence per se under a negligence standard of care legal responsibility analysis.

SOCALGAS has ignored these central issues in their legal analysis. In addition, they have ignored any legal issues related to strict liability. An entire body of law exists related to operating an abnormally dangerous activity, in which responsibility, or legal liability is imposed irrespective of the degree of care that is used in carrying out the operation. Namely, liability can be imposed even if SOCALGAS was able to show that they operated the PDR facility with utmost care.

The test to be used for determining if the PDR facility constitutes an abnormally dangerous activity is set forth in Restatement Second of Torts § 520:

In determining whether an activity is abnormally dangerous, the following factors are to be considered:

- (a) existence of a high degree of risk of some harm to the person, land or chattels of others;
- (b) likelihood that the harm that results from it will be great;
- (c) inability to eliminate the risk by the exercise of reasonable care;

(d) extent to which the activity is not a matter of common usage;

(e) inappropriateness of the activity to the place where it is carried on; and

(f) extent to which its value to the community is outweighed by its dangerous attributes.

Central to this evaluation are items (d) and (e). Regarding (d), the extent to which the activity of storing gas under high pressure in a partially depleted oilfield, in an urban setting, is certainly an activity that is not a matter of common usage. Regarding (e), the above-described activity is certainly an inappropriate activity to be carried out in a high-density residential location.

Regarding item (c), the “inability to eliminate the risk by the exercise of reasonable care,” is pivotal and central to this entire adversary proceeding, SOCALGAS has attempted to frame the legal issues in a context that would require them to make as few changes as possible to their current practices and procedures. The upshot of this nonaction by SOCALGAS to deal with the true gas migration hazards at the PDR facility would be the strong inference that there is an inability to eliminate the risk by the exercise of reasonable care.

In summary, the nonaction by SOCALGAS to deal with these gas migration hazards – during this adversary proceeding – is tantamount to “inviting” a strict liability level of responsibility upon SOCALGAS.

### CONCLUSIONS

There is a paramount need for SOCALGAS to set forth the specific policies and procedures that will allow proper monitoring and mitigation of the gas migration hazards at the PDR facility.



These policies and procedures should use as a primary framework the "Gas Inventory Monitoring, Verification, and Reporting Procedures" set forth in Exhibit 3 herein. Particular focus should be upon the shallow monitoring wells, and the gas collection wells detailed above in Section I. of this report.

In addition, these policies and procedures should focus on the surface casing leaks, including shoe leaks, that are enumerated in the SOCALGAS Rick Lorio Report, detailed above in Section I. of this report. This needs to include both active and abandoned wells.

Finally, a determination of responsibility by the Commission of the statement of issues as framed by SOCALGAS (see above) would be of no value in resolving the central issues of this Adversary Proceeding, as articulated in the Scoping Memo, as described above. In addition, to the extent that SOCALGAS is requesting the Commission to make a determination of legal ownership interests, including property rights involving the oil and gas mineral rights and/or storage, these property right determinations are under the jurisdiction of the Superior Court.

DATED: <sup>March</sup> February 26, 2007

Respectfully submitted,

By:

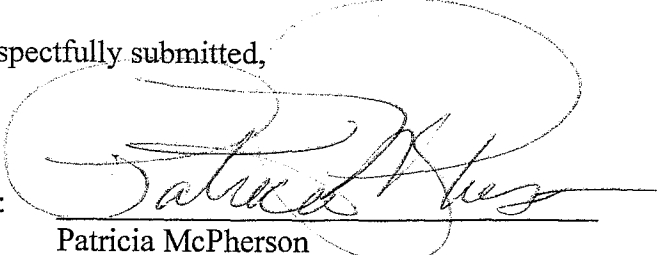
  
Patricia McPherson  
President, Grassroots Coalition

**CERTIFICATE OF SERVICE**

I hereby certify that I have this day served a copy of the foregoing **SOCALGAS LEGAL RESPONSIBILITIES REGARDING LEAKING AND MIGRATING NATURAL GAS AT THE PLAYA DEL REY GAS STORAGE PROJECT** on all known interested parties of record in C00-05-010, C00-05-011, and C00-05-012 by electronic mail included on the email list on the CPUC web site.

Dated at Los Angeles, California this 23rd day of February, 2007.

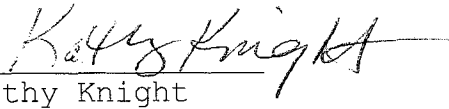
  
Kathy Knight

# EXHIBIT 1

THE PLAYA DEL REY  
MONITORING PROGRAM

Rick Lorio  
Associate Petroleum Engineer  
Underground Storage  
Southern California Gas Co.  
April 25, 1985

## TABLE OF CONTENTS

|                          | <u>Page</u> |
|--------------------------|-------------|
| I. Storage Zone Problems | 2           |
| II. Overview of Field    | 4           |
| III. Monitoring Program  | 6           |

## APPENDICES

|                |                                                                                                       |
|----------------|-------------------------------------------------------------------------------------------------------|
| Attachment 1 - | Examples of Casing Leak Types                                                                         |
| Attachment 2 - | Playa del Rey Well List                                                                               |
| Attachment 3 - | Playa del Rey Injection/Withdrawal<br>Schedule                                                        |
| Attachment 4 - | Helium Samples on Playa del Rey Pumping<br>Wells                                                      |
| Attachment 5 - | Examples of Temperature, Noise, and R/A<br>Tracer Survey Reports.                                     |
| Attachment 6 - | Playa del Rey Well Survey Status Report                                                               |
| Attachment 7 - | Examples of Abandoned Well Survey Reports,<br>Leakage Survey Report, and Leak<br>Investigation Report |
| Attachment 8 - | Playa del Rey Annulus Pressure Report                                                                 |

## I. Storage Zone Problems

### A. Possible source of gas migration to surface

There are at least five different possible sources of gas to the surface at Playa del Rey:

1. Casing leaks due to tubing/drill pipe wear, corrosion, stage collars, squeeze holes or metal failure.
2. Casing shoe leaks in active and abandoned wells.
3. Leaks from lower to upper zones outside the casing through uncemented or poorly cemented well bore in either active or abandoned wells.
4. Abandonment plug leaks inside the casings of abandoned wells.
5. Wellhead seal leaks.

### B. Three incidents of shallow casing leaks at Playa del Rey

Since Playa del Rey was converted to gas storage in 1942 for the war effort, there have been three incidents of shallow casing leaks. Two of these leaks had surface shows of gas and oil: 12-1 and 24-2, respectively.

1. In 1964, a casing leak was reported in Big Ben at about 150'. Repaired leak in 6-5/8" casing with Baash Ross casing bowl to 269'. The leak was determined to be at a depth of 269'.
2. On August 9, 1974, a gas leak was reported in the 13-1 block. The well 12-1 was determined to have a casing leak at between 700 and 800 feet. Bar hole surveys around the well and over the pipelines in the area indicated gas was appearing at the surface. The well was killed on August 15, 1974. From this time on, no gas was injected into the 13-1 block.
3. On April 30, 1975 at about 11:00 a.m., oil and gas surfaced on the east side of cellar wall. The well was producing through a leak in 7" casing at an unknown depth. They found corrosion in the

casing from 108' - 157'. Six weeks later well was returned to service. Currently, this well has an Otis subsurface safety valve located at 92'.

## II. Overview of Field

### A. Introduction

Playa del Rey oil field is about eleven miles west of Los Angeles, between Venice and Playa del Rey. Wildcatting was carried on in the vicinity of Playa del Rey for over eight years before the field was finally discovered. Drilling activities in the vicinity of Playa del Rey date back to May 14, 1921, at which time Del Rey 1 was spudded. This well was drilled to depth of 2785' without encountering any oil or gas showings, and was abandoned because of mechanical problems.

The first well drilled into the storage zone was on August 2, 1929. The Ohio Oil Company spudded the "Recreation Gun Club" 1. This well was drilled to a depth deeper than 6200'. A poorly sorted conglomerate, showing gas and oil, from 6114 to 6199 was discovered. While preparing to run a "water witch" to determine the nature and point of entry of the fluid, the well suddenly came in December 18, 1929, and flowed through the casing at an estimated rate of 2500 barrels of oil and 1,500,000 cubic feet of gas per day with the oil having an API of 21.6°.

On August 4, 1942, the Commission decided that Playa del Rey appeared feasible for Underground Storage from an engineering and economic standpoint. The government decided that Union Oil Company of California was to act as the operating contractor for Defense Plants Corporation, and the Southern California Gas Company as the gas utility to store and withdraw gas. From that time, the storage zone has increased from a field deliverability of approximately 10 MMcf/hr to about 25 MMcf/hr. Currently, Southern California Gas Company has 72 active wells in Playa del Rey.

### B. Well Lists

There are 72 active wells in this field. These wells are divided into four groups:



|    |                            |    |
|----|----------------------------|----|
| 1. | Injection/withdrawal wells |    |
|    | Storage wells              | 28 |
| 2. | Flowing wells migration    |    |
|    | Return                     | 2  |
| 3. | Pumping wells:             | 10 |
|    | a. Fluid removal           |    |
|    | b. Pressure relief         |    |
| 4. | Observation wells          | 32 |

These wells comprise the Playa del Rey storage operation.

C. Storage Areas

There are five distinct areas in the Playa del Rey storage field. Each of these areas has distinct operating functions.

1. 13-1 Fault Block
2. 24-1 Fault Block
3. Del Rey Main Area
4. Del Rey Gas Cap
5. Venice Townlot area

13-1 Fault Block

The 13-1 fault block has not been used for injection/withdrawal operations since 1974 when a shallow leak at well 12-1 brought gas to the surface at nearby houses. This block includes wells 12-1, 13-1, Colly 2, Colly 10, Harper, Hisey, Kelly and Merrill. Should this block be determined feasible to return to operations, other factors need to be considered. All of the wells in this block are in a residential area and will require subsurface safety valves with which they are already equipped. These wells have not been operated for some time; and thus the question is whether or not the neighbors will tolerate the increased noise level required to operate these wells.

The 13-1 fault block is geologically connected but not pressure connected. This block is an upthrown fault block, gas can migrate in, but the block holds pressure indicating that gas accumulates.

### 24-1 Fault Block

This fault block is used in tandem with the main storage area. It has no other purpose other than to remove fluid from this east flank.

### Del Rey Main Area

This is the storage zone area. The operating guidelines are to withdraw from low structure wells first and work towards the higher structures. There are twenty-eight injection/withdrawal wells located in this area.

### Del Rey Gas Cap

The wells located in this area of the field are primarily used for observation. Two of these wells are also used for gas migration return Del Rey 15 and Del Rey 18.

### Venice Townlot Area

The wells in this area have a dual purpose: pressure relief (fluid removal) and gas migration (observation).

Early in the usage of Playa del Rey as a gas storage reservoir, it was discovered that certain oil productive areas, previously considered to be structurally separate deposits were really pressure connected. The areas in question were the Del Rey Gas Cap, Del Rey Hills Area, Del Rey Main Area and the Venice Townlot area. Parts of this reservoir are apparently geologically connected but not pressure connected.

Block 10R, Block 11, Townsite 2, Townsite 3, Townsite 11 and Troxel are located in this part of the field. Troxel, however, is on the other side of a fault block. Helium tests have indicated storage gas production from this area of the field.

### III. Monitoring Program

#### A. Temperature, Noise and Tracer Surveys

All of the wells at Playa del Rey with the exception of tire pumping wells have temperature surveys run on a quarterly basis. These surveys provide the information needed to determine well leaks. When a well leaks, the expanding gas from the leak cools both the pipe and surrounding formation. On a temperature survey, the leak appears as a cooling anomaly on a temperature survey.

Gas storage technicians run temperature surveys quarterly using company-owned wireline units. If a cooling anomaly appears on the temperature survey, a noise survey is run to verify the leak. If indicated, a radioactive tracer survey (R/A) is run which pinpoints the exact location of the leak and provides data necessary to estimate the rate of gas loss. During the 1st five years, only two R/A tracer surveys were run. They were on Big Ben and 12-1. Big Ben had a casing leak at 1065', and well 12-1 had a leak between 168' and 230'.

#### B. Surface Observation

All active well cellar areas are inspected each month for indications of near surface gas migration by station personnel. Any bubbles are analyzed for hydrocarbon and helium content. The resident reservoir engineer requests the analysis, and reviews and maintains records of the results. If storage gas is forced, the senior petroleum engineer is notified.

Once a month at Playa del Rey, the station personnel survey the four permanent bar holes that are near all active wells with a gas scope or flame ionization unit.

Twice a year, the station surveys the bar holes in the vicinity of abandoned wells with the flame ionization unit to detect any near surface gas migration under the direction of the South Basin Pipeline Superintendent.

Once a year, all storage field pipelines are surveyed using the flame ionization unit to detect any near surface gas migration.

C. Storage Zone

1. Surface pressures in each well are measured and recorded weekly using a calibrated test gauge. The data recorded for each well are:

Tubing pressure  
Casing pressure  
Annuli pressure  
Safety valve control-line pressure  
Mode of operation

2. A plot of weekly surface casing and innerstring annuli pressures versus time is maintained for each well.
3. Wellhead inspections are performed once a month.
4. Subsurface temperature survey are performed on a quarterly basis.

D. Gas Cap Observation Well

Vidor 6 is Playa del Rey's GCOW used to observe gas bubble pressures. This well is not used for injection and is used for withdrawal only for peak load conditions. The surface pressure measurements on the tubing and casing of Vidor 6 is recorded and plotted daily.

RMM:mm  
April 25, 1985

**EXHIBIT I**  
**CASING LEAKS: TYPE 1**

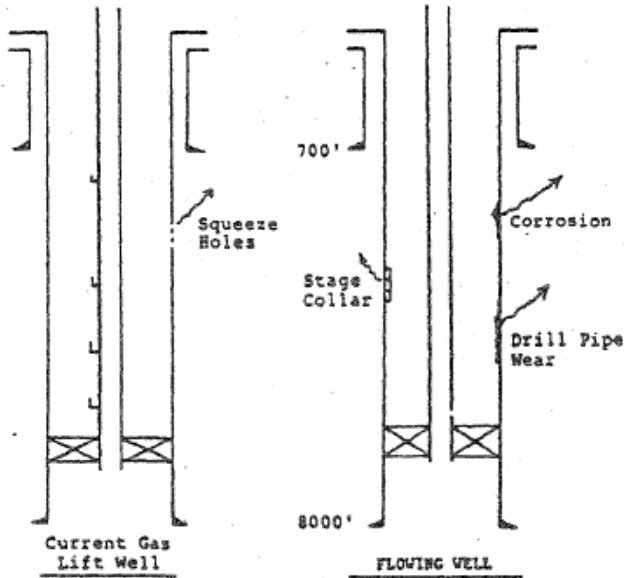

**PROBLEM:**

Casing leaks that allow high pressure gas into low pressure, shallow zones.

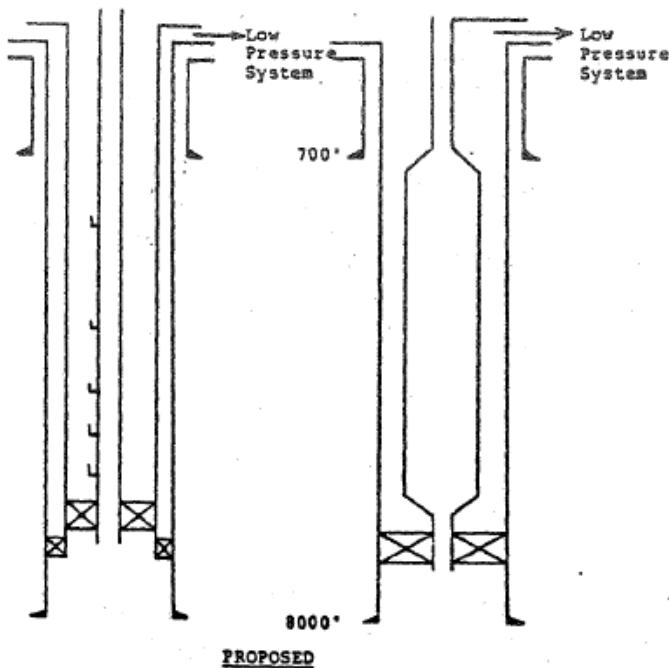

**SOLUTION:**

Use innerstrings and/or tubing to confine all high gas pressure. Keep innerstring or tubing annulus pressure lower than that required to force gas into acquirer sand at shoe of surface casing by venting gas to atmosphere or to low pressure system. Withdrawal wells' deliverability can be kept high by using large tubing.

EXHIBIT I  
CASING SHOE LEAKS: TYPE 2

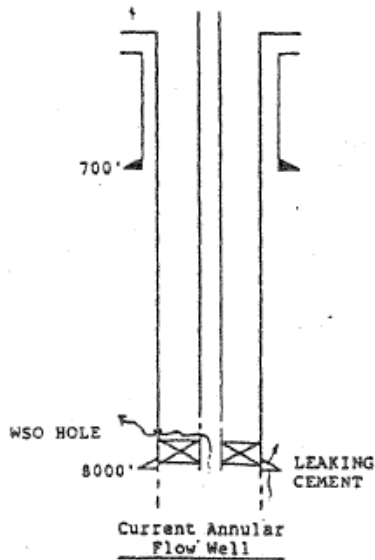

**PROBLEM:**  
Casing shoe leaks due to poor, deteriorated cement or to leakage through WSO holes in active or abandoned wells.

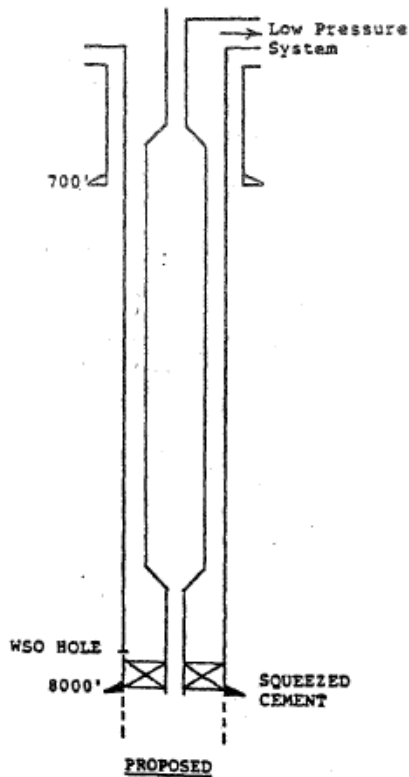

**SOLUTION, ACTIVE WELLS:**  
Squeeze cement into shoe area. Place tubing packer below WSO holes where possible.

**ALTERNATE SOLUTION, ACTIVE WELLS:**  
Do not repair if leak is into 7th zone but no higher. Collect all free gas from the 7th zone by activating more collection wells.

**SOLUTION, ABANDONED WELLS:**  
Collect all free gas from overlying zones. Repair work not possible.

EXHIBIT I  
UNCEMENTED WELLBORE LEAKS: TYPE 3

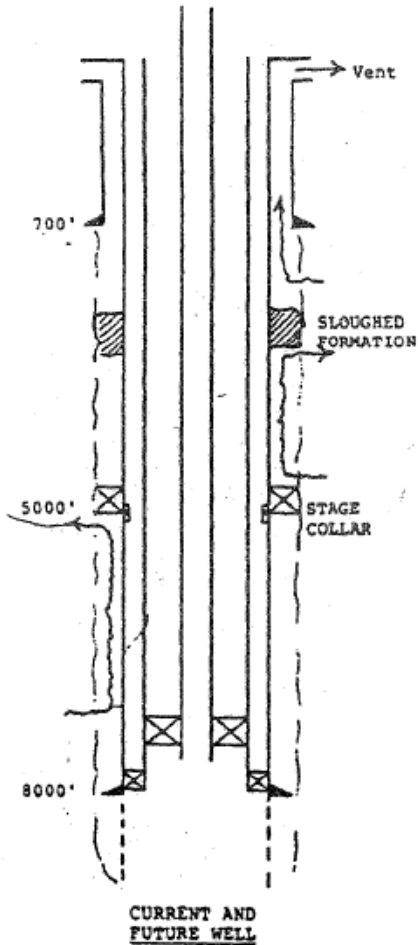

**PROBLEM:**  
All wells have some uncemented segments. Few wells have any cement above 2000'. Formation sloughing may have filled in some of these wellbores but most remain the most permeable upward path for gas migration.

**SOLUTION:**  
Noise and TDT monitor active wells to find areas of increasing activity. Continually produce shallow zones. Vent to atmosphere all gas coming from surface casing shoe aquifer.

JWT:hs  
2/9/84

EXHIBIT I  
PAGE 3

**EXHIBIT I**  
**ABANDONMENT PLUG LEAKS: TYPE 4**

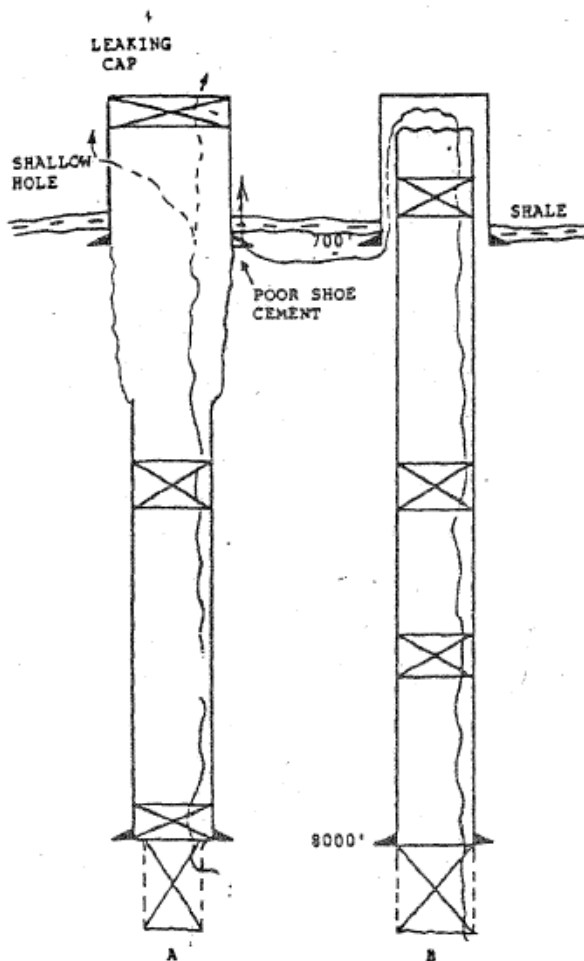

**EXISTING ABANDONED WELL TYPES**

**PROBLEM, TYPE A ABANDONMENT:**

Cement plugs inside casing allow some gas to migrate upwards. Because its casing was cut off below the surface string, water will continue to fill casing as gas leaks out. Leak will therefore be sporadic and low rate.

**PROBLEM, TYPE B ABANDONMENT:**

Cement plugs inside casing allow some gas to migrate upwards. Because the casing stub is cut off within 100' of surface, the entire surface casing fills with gas. No liquid enters the well. The gas leak unloads fluid from the well and the rate increases with time. Eventually all of the fluid unloads and the leak rate stabilizes at a near constant daily rate.

**PROBLEMS, BOTH TYPE ABANDONMENTS:**

1. Casing cap, surface casing and casing shoe cement competent. Gas will build up inside surface casing and force its way into shallow aquifer sand. Gas will surface at a non-leaking well that has the following problems.
2. Casing cap not competent. Gas will surface near well.
3. Surface casing or shoe cement not competent. Gas will spread over large area as it rises to surface lethargically.

**SOLUTION, PROBLEM 1:**

Direct repair of leaking well not possible because source well is unknown. Other wells where gas appears are continually vented to surface.

**SOLUTION, PROBLEM 2:**

Unearth well and recap or place collection funnel over it. Rig work not required. Vent all gas to atmosphere.

**SOLUTION, PROBLEM 3:**

Unearth well, move in rig, attempt to enter and repair old casing. Produce gas through casing into low pressure system. Vent surface annulus to atmosphere.



**EXHIBIT I**  
**WELLHEAD LEAKS: TYPE 5**

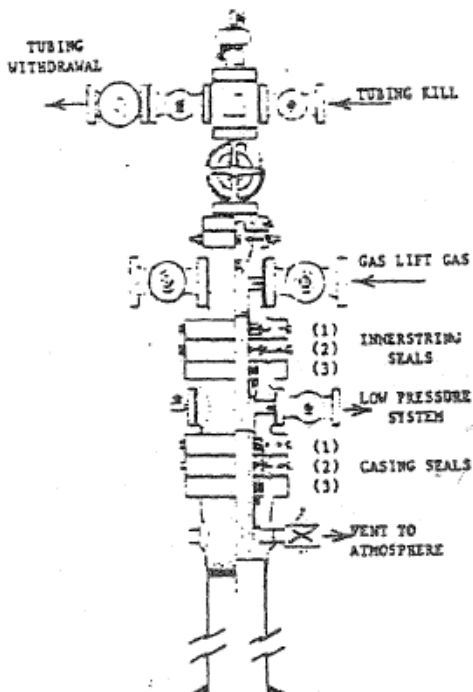

**CURRENT AND PROPOSED  
WELLHEAD FOR WELLS  
WITH INNERSTRINGS**

**PROBLEM:**  
Wellhead seal leaks allow high pressure gas to leak into the innerstring, tubing or surface casing annulus. Gas then enters shallow zones at the surface casing shoe or through casing holes.

**SOLUTION:**  
Keep all annular pressures below that required to force gas into shallow zones either by connecting them to low pressure system or venting them to atmosphere. Install new wellheads with triple seals (as illustrated) on wells with obsolete equipment when other well work is performing or when wellhead is leaking badly.

- (1) Inject sealant to energize seal in head
- (2) Inject sealant to energize seal in sealing flange
- (3) Set down weight on slips to energize seal

JWT:hs  
2/9/84

**EXHIBIT I**  
**Page 5**

# EXHIBIT 2

## CHRONOLOGY OF WELL COMPLETIONS

| Operator                        | Well No.                 | Date of completion |
|---------------------------------|--------------------------|--------------------|
| Union Oil Co. of California     | "King Vidor" 1           | May 23, 1931       |
| Union Oil Co. of California     | "Del Rey" 4              | May 8, 1932        |
| Union Oil Co. of California     | "King Vidor" 2           | Dec. 4, 1932       |
| Union Oil Co. of California     | "King Vidor" 3           | May 10, 1933       |
| Union Oil Co. of California     | "Del Rey" 5              | July 19, 1933      |
| Union Oil Co. of California     | "King Vidor" 5           | April 17, 1934     |
| Chas. W. Fourl                  | "Fourl" 1                | Nov. 16, 1934      |
| Union Oil Co. of California     | "King Vidor" 6           | Jan. 24, 1935      |
| Union Oil Co. of California     | "King Vidor" 7           | Feb. 26, 1935      |
| D. D. Dunlap Oil Co.            | "Del Rey" 1              | Feb. 26, 1935      |
| McAdams Oil Co.                 | "Del Rey" 1              | Mar. 14, 1935      |
| D. W. Elliott                   | "Del Rey" 1              | Mar. 21, 1935      |
| Union Oil Co. of California     | "King Vidor" 8           | Mar. 26, 1935      |
| Royalty Service Corp., Ltd.     | "Del Rey" 1              | Mar. 30, 1935      |
| Pacific Drilling Corp.          | "Del Rey" 1              | April 20, 1935     |
| Chas. W. Fourl                  | "Fourl" 3                | April 24, 1935     |
| Dunlap Petroleum Co.            | 1                        | May 11, 1935       |
| Rite-Lube Oil Co.               | "Ray" 1                  | May 17, 1935       |
| Union Oil Co. of California     | "King Vidor" 9           | May 19, 1935       |
| Royalty Service Corp., Ltd.     | "Pomoc" 1                | May 26, 1935       |
| Colly Oil Co.                   | "Colly" 1                | May 31, 1935       |
| Union Oil Co. of California     | "King Vidor" 10          | June 2, 1935       |
| Red Seal Oil Co., Ltd.          | "Big Ben" 1              | June 4, 1935       |
| Chas. W. Fourl                  | "Fourl" 4                | June 5, 1935       |
| Coast Petroleum Co.             | "Stockburger" 1          | June 7, 1935       |
| Thos. Kelly & Laurence O. Kelly | "T. & L." 1              | June 13, 1935      |
| Union Oil Co. of California     | "Del Rey" 9              | June 15, 1935      |
| McAdams Oil Co.                 | "Del Rey" 2              | June 16, 1935      |
| Lor Mar Oil Development Co.     | "Lor Mar" 1              | June 24, 1935      |
| Colly Oil Co.                   | "Colly" 2                | June 24, 1935      |
| Red Seal Oil Co., Ltd.          | "Ben" 2                  | June 27, 1935      |
| Royalty Service Corp., Ltd.     | "Del Rey" 2              | July 1, 1935       |
| Embee Oil Co.                   | "Embee" 1                | July 3, 1935       |
| Williams & Harper               | "Williams-Harper" 1      | July 3, 1935       |
| Royalty Service Corp., Ltd.     | "Del Rey" 13-1           | July 15, 1935      |
| Union Oil Co. of California     | "King Vidor" 11          | July 27, 1935      |
| Royalty Service Corp., Ltd.     | "Del Rey" 12-1           | Aug. 5, 1935       |
| Red Seal Oil Co., Ltd.          | "Ben" 3                  | Aug. 20, 1935      |
| Del Rey Realty Co.              | "Herndon Development" 29 | Aug. 21, 1935      |
| Union Oil Co. of California     | "King Vidor" 12          | Sept. 13, 1935     |
| Royalty Service Corp., Ltd.     | "Del Rey" 23-1           | Sept. 26, 1935     |
| Union Oil Co. of California     | "Del Rey" 11             | Oct. 18, 1935      |
| Union Oil Co. of California     | "King Vidor" 13          | Oct. 24, 1935      |
| Birch-Royer Oil Co.             | "Hisey-Thrall" 1         | Nov. 22, 1935      |
| Otis Hoyt Co.                   | "Del Rey" 1              | Dec. 3, 1935       |
| Union Oil Co. of California     | "King Vidor" 14          | Jan. 12, 1936      |
| Union Oil Co. of California     | "Del Rey" 12             | Jan. 27, 1936      |
| G. C. Woodard, Agent            | "Milham" 1               | Feb. 20, 1936      |

# EXHIBIT 3

**APPENDIX A**

**GAS INVENTORY MONITORING,  
VERIFICATION, AND REPORTING PROCEDURES**

## I. GENERAL

Gas Storage Operations require monitoring and inventory verification for safe long-term management of underground gas storage operations. While no single method can be used to precisely monitor and verify the gas inventory in underground storage reservoirs, the three engineering methods in general use are summarized below. Gas volume verification can be obtained only by combining and analyzing available field data. Based on this analysis, gas volume changes or losses are recognized, estimated and reported.

## II. DEFINITIONS

When gas storage operations are initiated in an oil or gas reservoir, there is an initial gas content in the reservoir prior to injection. Initial gas content is generally composed of both free gas and solution gas. Additional gas is added to the initial gas content by injection, and the combination comprises the Total Storage Volume. This volume is categorized as follows:

### A. Cushion Gas

The base gas is that quantity of gas which must be in the reservoir to maintain the minimum pressure required to exclude fluids from the gas cap and to provide the energy required to deliver the minimum required rate of gas withdrawal at the end of the withdrawal season.

### B. Recoverable Cushion Gas

This is defined as the volume of gas that can be economically recovered from the reservoir below the base gas pressure. This volume varies, depending upon economic conditions.

### C. Non-Recoverable "Cushion Gas"

This is the volume of gas left in the reservoir after all recoverable gas volumes are removed and is not considered a part of Total Storage Inventory. This gas is capitalized and depreciated over the life of the project.

### D. Working Gas

This volume is defined as the gas content which is held in the reservoir between maximum reservoir pressure and the base gas pressure.

### E. Effective Working Gas

This volume is defined as the working gas which is withdrawn and re-injected in a complete injection and withdrawal cycle. Ideally, the effective working gas volume is synonymous with the working gas volume. However, limitations by wells, compression facilities, or gas availability may limit effective working gas volume.

F. Total Storage Inventory

This is the sum of all working and recoverable cushion gas volumes.

**III. RESPONSIBILITY**

The responsibilities for shut-ins, along with analyzing data, verifying gas inventory, and reporting changes or losses are specified in System Instruction 224.0020.

**IV. MONITORING**

A. Monitoring of the storage reservoir is required to ensure reservoir integrity and field deliverability. The performance review ensures the reservoir functions according to expectations, and integrity tests verify the gas inventory is present and available for delivery. Effective monitoring requires a thorough understanding of the reservoir system. This system is defined as the reservoir rock and wellbores which respond to pressure changes as a result of gas injection and withdrawal. To better understand the system, see System Instruction 224.0035, *Gas Inventory - Summary of Reservoir System*. A successful monitoring program reduces risk of injury, property damage and gas migration.

B. Monitoring of the reservoir system is conducted in both storage and non-storage zone wells and at surface observation points.

1. Storage Zone Wells

a. Performance reviews utilize information collected during individual well and reservoir tests. Back pressure curve shifts, changes in deliverability and field performance are investigated.

b. Tests are conducted on individual wells to prove both well and reservoir integrity.

i. Surface pressures on each well are measured and recorded weekly using a calibrated test gauge. Pressures measured and recorded include tubing pressure, casing pressure, annuli pressures, and, if applicable, safety valve control line pressure. The mode of well operation (injection, withdrawal or shut-in) at the time of pressure measurement is also recorded. Note that the *C.D.O.G.G.R. (California Division Of Oil Gas and Geothermal Resources)* requires a monthly average casing and tubing pressure recorded and submitted as part of the monthly production report.

ii. A plot of the weekly surface casing and the innerstring annuli pressures versus time is maintained or periodically produced for each well. Hardcopy plots are created, marked and filed when an abnormal pressure is

encountered. A pressure is considered abnormal when it may be large enough to force gas into a normally pressured water sand, either at the surface casing shoe or through any other known casing holes or leak-paths.

- iii. When abnormally high annular pressures are detected, diagnostic steps are taken to determine the source of pressure build up. This includes tests to eliminate surface valves and downhole tubing as possible sources of leakage. Zero pressure is abnormal in a well that has had a history of annular pressure and is investigated for the possibility of a closed valve.
- iv. All wells with continuing zero pressure readings are checked quarterly for closed valves and noted on the pressure plot. Blowdowns are also noted when they occur.
- v. Wellhead inspections are performed on a monthly basis. Any leaks from wellhead flanges and valves are reported and corrected.
- vi. Subsurface temperature surveys are conducted on each well in according to the following schedule: semi-annually in La Goleta, Montebello, and Playa del Rey storage fields and annually in the Aliso Canyon, and Honor Rancho Storage fields.
- vii. Surveys are done in accordance with System Instruction 224.0025, *Standardized Subsurface Temperature and Pressure Surveys*. Wells that have been killed are not exempt from this requirement and must be surveyed according to the schedule. Results of surveys are reported according to Recommended Method 224.001, *Standardized Daily Well Operations Report*.
- viii. Additional surveys will be run without regard to this schedule at the first indication of unusual or abnormal well conditions, i.e., anomalous pressure, surface gas emissions or other indications of well problems.
- ix. Wireline retrievable tubing obstructions such as tubing plugs, subsurface safety valves, subsurface chokes or tubing stops are removed once each year to perform a temperature survey of the casing shoe and cap rock seal. Ideally, this is done at high reservoir pressure when shoe leaks are most noticeable on temperature surveys.



Under certain conditions it may not be possible or advisable to remove the wireline retrievable obstruction.

- x. Subsurface surveys using wireline conductor cable equipment are made to investigate anomalies discovered by temperature surveys.
- xi. Conductor cable surveys include temperature surveys, noise logs, spinner surveys, and radioactive tracer surveys.
- xii. In the case of well casing leaks above the shoe, radioactive tracer surveys are typically used to verify the location of gas movement through the leak. In the case of shoe or cap rock leaks, these additional surveys are used to verify that a leak exists and as an aid to qualitatively estimate leakage rate.

c. Reservoir integrity tests include:

- i. Gas cap observation wells are used to monitor reservoir pressure. If possible one or more wells completed in the gas cap are selected for observation purposes. These wells are not used for injection and are put on withdrawal only for peak load conditions. Surface pressure measurements on the tubing and casing of each gas cap observation well are made and recorded weekly.
- ii. A plot of these pressures versus inventory is kept in the office of the Storage Field Engineer and is updated weekly. Anomalous well pressures or behavior are reported to Storage Engineering Staff.
- iii. Reservoir shut-ins are generally on a schedule stated in System Instruction 224.0020 or when determined as necessary by the Storage Field Engineer. The

**2. Non-storage Zone Wells**

- a. Non-storage zone wells monitored include both Company wells and wells owned by others in overlying and underlying zones and in other fields within two miles of the storage reservoir boundary, where applicable. These wells are categorized as follows:
  - i. Pressure observation wells are located in overlying and underlying permeable formations, or adjacent to the storage reservoir but across assumed confining boundaries, such as faults, permeability pinchouts, below the gas-liquid contact or beyond the spill point of the storage zone's confining structure. Although normally static, these wells may have artificial lift mechanisms for removal of gas and fluids.
  - ii. Gas collection wells are located where known gas migration from the storage zone is intercepted and collected. These wells are normally equipped with operating artificial lift mechanisms so that both liquids and gas can be produced, causing a pressure sink in the reservoir near the wellbore.
  - iii. In some fields, shallow water observation wells have been drilled into aquifer zones existing in the first permeable sand above the shoe of the surface casing. These wells are closed in at the surface and gas concentrations in the wellbore are measured weekly.
  - iv. If gas loss is expected, performance reviews of wells operated by other producers in either overlying zones or in adjacent fields may be made by reviewing production reports from these operators.
  - v. Performance of Company-owned observation and collection wells are also closely monitored. Wellhead inspections and temperature surveys are performed on the pressure observation wells and the gas collection wells.
  - vi. Pressure observation wells
    - a. Surface pressures on all tubing and casing strings are measured weekly using a calibrated test gauge.
    - b. A plot of pressure versus time for each well is kept by the Storage Field Engineer. Bottom-

hole pressure surveys are run as needed on pressure observation wells.

- c. If a substantial increase in reservoir pressure is noted or a significant gas buildup occurs, an attempt is made to produce the well. Produced gas is sampled and analyzed for both hydrocarbon and helium content.

vii. Gas collection wells

- a. Surface pressures on all casing strings and safety valve control lines are measured weekly using a calibrated test-gauge. The mode of well operation (producing, shut-in) at the time of pressure measurement is also recorded.
- b. A plot of pressure vs. time for each surface casing and innerstring annulus is kept by the Storage Field Engineer.
- c. Bottom-hole pressure surveys are run on gas collection wells as needed. These surveys follow a shut-in period to allow pressure stabilization after production. If the well is equipped with a standing valve, the valve is pulled prior to the bottom-hole pressure survey and is reinstalled upon completion of the survey.
- d. Production schedules are developed by the Storage Field Engineer. The Storage Field Engineer maintains plots of bottomhole pressure versus time and records of produced gas, oil and water.

viii. Shallow water observation wells

- a. Shallow water observation wells are closed-in at the surface and gas concentrations in the wellbore measured periodically.

ix. Surface Observations

- a. Active well cellar areas are inspected by station personnel each month for indications of near surface gas migration. The Storage Field Engineer requests the analysis if needed and reviews and maintains records of the results.

- b. Region personnel survey the location perimeter of four permanent bar holes near all active wells with a gas scope or flame ionization unit. The surveys are performed monthly at Montebello, quarterly at La Goleta, and semi-annually at Aliso Canyon, East Whittier, Honor Rancho and Playa del Rey.
- c. The areas in the vicinity of abandoned wells are examined with a flame ionization unit to detect any near surface gas migration under the direction of the Storage Operations Manager. Surveys are performed semi-annually at Montebello, and annually at Aliso Canyon, East Whittier, Honor Rancho, La Goleta and Playa del Rey.
- d. Flame ionization surveys to detect any near surface gas migration are performed on all storage field pipelines under the direction of the Storage Operations Manager. These surveys are performed annually at La Goleta, Montebello, and Playa del Rey and every two years at Aliso Canyon, East Whittier and Honor Rancho.

## V. BOTTOM-HOLE PRESSURE DETERMINATION

- A. Each of the three major methods used to verify gas storage inventory, as explained in Section V, requires the determination of bottom-hole pressures in the field wells. The method used to determine bottom-hole pressure must be consistent from year to year. The most accurate method to determine bottom-hole pressure is to measure the pressure with a pressure bomb. In certain applications the bottom-hole pressure can be calculated from the shut-in wellhead pressure. For wells completed in the gas cap and having full gas columns, the bottom-hole pressure is calculated from the equation:

$$P_{BHP} = P_{WH} \exp\left(\frac{0.01875 \times SG \times D}{Z_{avg} T_{avg}}\right)$$

Where:

$P_{BHP}$  = Bottom-hole pressure, psia.

$P_{WH}$  = Wellhead pressure, psia.

SG = Gas specific gravity.

D = True vertical depth in feet.

$T_{avg}$  = Average wellbore temperature between surface and bottom-hole, degrees Rankin.

$Z_{avg}$  = Average gas compressibility factor from charts, tables or computer programs (dependent on  $P_{avg}$ ,  $T_{avg}$  and gas gravity).

$P_{avg}$  = Average pressure between surface and bottom-hole, psia or  
$$P_{avg} = (P_{BHP} + P_{WH}) / 2$$

NOTE: The above equation could yield incorrect results if the well exhibits abnormally high surface pressure or high fluid levels.

## VI. INVENTORY VERIFICATION — SHUT IN

- A. Three primary methods for inventory verification of Gas Storage Fields are referenced and summarized below:
1. Calculation of gas content based on volumetric data and average reservoir pressure; Volumetric Determination is explained in *Applied Petroleum Reservoir Engineering*; by Craft, B. C. and Hawkins, M. F.; Englewood Cliffs, N.J.: Prentice-Hall, 1959.
  2. Calculation of effective gas content using the simple gas material balance, hysteresis curve, and P/Z curve methods; Material Balance is explained in *Natural Gas Engineering* by Ikoku, C. V.; Tulsa, Oklahoma: Penn Well Publishing, 1980.
  3. Verification of storage inventory by comparing measured reservoir pressures with calculated pressures obtained using the single cell material balance or reservoir simulation methods; Numerical Simulation or Reservoir Modeling is explained in *Modern Reservoir Engineering — A Simulation Approach* by Crichtlow, H. B.; Englewood Cliffs, N.J.: Prentice-Hall, 1977 and the *Intercomp Beta II User Manual*.
- B. The most common inventory verification method used in mature gas storage projects that are known to have effective geologic closure is the hysteresis curve or P/Z versus inventory plot. Typically, it is adjusted annually for known gas losses and liquid production. Any shift between points plotted at similar pressures following a shut-in is further investigated.
1. Tracking known gas losses and transfers as they occur assist with inventory verification.

2. Recommended Shut-in time durations for effective reservoir stabilization are listed below
  - Aliso Canyon -14 days
  - Honor Rancho -12 days
  - Goleta- 5 days
  - Montebello -12 days
  
- C. Data collected during a shut-in period includes accurate measurements of reservoir pressure on each available well. Bottom-hole pressures can be calculated from surface pressures or measured directly. Gas gravity is determined using gas samples from individual, representative wells.
  
- D. The Storage Field Engineer chooses the type and frequency of data to be collected during shut-ins.
  
- E. Calculation of gas content based on volumetric data and average reservoir pressure from shut-in.
  1. Average reservoir pressures used in this calculation are obtained during shut-in periods required for reservoir pressure stabilization. Reservoir pore volumes available for gas storage are calculated from either geologic information, material balances using production and pressure information obtained during primary field production, or in some cases from pressure and production data obtained during gas storage operations. Elements of these calculations are described below:
  
  2. Average reservoir pressures are calculated in an appropriate way for each storage reservoir. To be reliable, the method for each field should stay consistent for all years. Various methods of calculation include the following:
    - a. The average reservoir pressure for Honor Rancho, La Goleta, and Playa del Rey are determined by calculating the arithmetic average of the bottom-hole pressure in the gas cap wells. In these fields the pressure of each well is measured or computed at a specified subsea datum approximately at the midpoint of the zone. The datum and reservoir temperature used for these fields are as follows:
      - i. Honor Rancho - 8,300 feet subsea, 190°F
      - ii. La Goleta - 4,200 feet subsea, 150°F
      - iii. Playa del Rey - 6,100 feet subsea, 210°F

- iv. Montebello: An average reservoir pressure is obtained. The pressure points for the average reservoir pressure are generated by converting the bottom-hole pressure to a datum at the top of the 8-2 zone using a reservoir temperature of 187°F.
  - v. A volumetrically weighted average reservoir pressure is used for Aliso Canyon. The pressures in this field is computed at a specified subsea depth approximately at the midpoint of the zone. The datum depth for this field and the reservoir temperature is as follows:
    - a. Aliso Canyon - 5,400 feet subsea, 180°F
3. Reservoir pore volume calculated from geologic information utilizes data obtained during the drilling and completion of the well such as electric logs or core information to calculate the total pore volume of the reservoir. These calculations are based on the following equations:

a. Gas reservoirs

i. Equation:  $V = Ah\phi(1-S_w)$

Where:

V = Reservoir gas pore volume in cubic feet

A = Gas zone area in square feet

h = Average gas zone thickness in feet determined from electric logs or cores

$\phi$  = Porosity fraction determined from porosity logs or well test analysis

$S_w$  = Water saturation from log, core, or well test analysis

b. Oil reservoirs

i. Equation:  $V = Ah\phi(1-S_w) + A_1h_1\phi(1-2w-s_o)$

Where:

A = Primary gas cap area in square feet

$A_1$  = Secondary gas cap area in square feet

$h_1$  = Average secondary gas zone thickness in feet

$s_o =$  Residual oil saturation

- ii. In most portions of an oil zone storage reservoir, oil saturation is determined from core analysis or can be considered equivalent to residual oil saturation and can be estimated from the 16" normal resistivity curve using the following relationships.

Equation: Residual oil saturation =  $(1 - s_{xo})$

$$s_{xo} = \sqrt{\frac{R_{mf}}{R_{xo} \phi^2}}$$

Where:

$R_{xo} =$  Resistivity of 16" normal or resistivity of flushed zone.

$S_{xo} =$  Water saturation of mud filtrate within the flushed zone.

$\phi =$  Porosity

$R_{mf} =$  Resistivity of mud filtrate.

- 4. Gas Reservoir pore volume calculated using material balance equations:

These calculations utilize production and pressure data in the following equations:

- a. Equation for constant volume gas reservoirs using primary production:

$$V = \frac{P_{sc} G_p T}{T_{sc}} \left( \frac{1}{P_i / Z_i - P_f / Z_f} \right)$$

Where water production and influx are assumed negligible and where:

$V =$  Gas pore volume in reservoir cubic feet.

$P_{sc} =$  14.7 psia

$G_p =$  Gas produced in standard cubic feet.

$T =$  Reservoir temperature in degrees Rankin ( $^{\circ}R$ ).

$R_{sc} =$  520 $^{\circ}R$



$P_i$  = Initial pressure, psia.

$P_f$  = Final pressure, psia.

$Z_i$  = Initial gas compressibility factor.

$Z_f$  = Final gas compressibility factor.

- b. Equation for constant volume gas reservoirs using storage production

$$V = \frac{P_{SC} G_P T}{T_{SP}} \left( \frac{1}{P_1 / Z_1 - P_2 / Z_2} \right)$$

Where water production and influx are assumed negligible

$G_p$  = SCF of gas produced or injected between pressure points  $P_1$  and  $P_2$ .

$P_1$  and  $P_2$  = The first and second stabilized average reservoir pressures bounding the production or injection period considered.

$Z_1$  and  $Z_2$  = Gas compressibility factors for  $P_1$  and  $P_2$ .

$T$  = Reservoir temperature in degrees Rankin

5. Oil reservoirs pore volume calculations

- a. Equation: The 'Reservoir Gas Pore Volume' is equal to the 'Original Gas Cap Pore Volume' plus the 'Secondary Gas Cap Pore Volume' plus the 'Space created by Water Production'.

Or:

$$V = GB_{gi} = (NB_{oi} - (N - N_p)B_o) + W_p B_w$$

Where:

$G$  = Original gas pore volume, standard cubic feet (determined from either geologic data or an appropriate form of the material balance equation).

$B_{gi}$  = Gas formation volume factor in reservoir cubic feet per standard cubic feet at discovery pressure.

$N$  = Initial oil in place in stock tank barrels (determined from either geologic data or an appropriated form of the material balance equation).

$N_p$  = Cumulative oil production in stock tank barrels.

$B_{oi}$  = Oil formation volume factor in reservoir cubic feet per stock tank barrel at discovery pressure.

$B_o$  = Oil formation volume factor at existing pressure in reservoir cubic feet per stock tank barrel.

$W_p$  = Water production in stock tank barrels.

$B_w$  = Water formation volume factor, reservoir cubic feet per stock tank barrel (approximates 5.615).

- b. Simplifying assumptions used in the above equation are that no storage gas goes into solution in the oil and that there is no water influx into the storage reservoir. These simplifying assumptions are seldom true. However, the equation can be modified based on a judgment of the volume of gas which may go into solution in the reservoir oil and a judgment of aquifer activity surrounding the storage reservoir. When modified by these judgment factors, the equation provides a method for approximating a limit for the reservoir gas pore volume available for storage operations. An upper limit is established when it is assumed that all the residual oil is resaturated with gas. Generally, only a fraction of the oil becomes saturated and so the calculation has little usage beyond setting limits.
- c. The values of  $G$  and  $N$  are not generally expected to be obtained with an accuracy greater than + 20%. However, this is not a major drawback since the methods are used to establish guidelines and set limits.

6. Calculation of gas content.

- a. After the gas pore volume has been calculated, or approximated, by one of the methods indicated above, the gas content at the measured reservoir pressure is determined using the gas law as follows:

$$PV = ZNRT$$

Where:

$P$  = Average reservoir pressure, psia

**GAS INVENTORY — MONITORING, VERIFICATION, AND REPORTING**  
**RECOMMENDED METHOD: 224.070**

---

- V = Gas pore volume in reservoir cubic feet
- T = Temperature of reservoir, (°F + 460) degrees Rankin
- Z = Compressibility factor, dependent on P, T, and gas gravity, from charts or tables.
- N = pound moles (where one pound mole = 379.41 cubic feet @ 60°F and 14.7 psia).
- R = 10.735 universal gas constant for above units.

Solving for gas content;

$$Volume(mscf) = \frac{(0.03533)PV}{ZT}$$

$$PV = ZNRT$$

Where:

- P = Average reservoir pressure, psia
- V = Gas pore volume in reservoir cubic feet
- T = Temperature of reservoir, (°F + 460) degrees Rankin
- Z = Compressibility factor, dependent on P, T, and gas gravity, from charts or tables.
- N = pound moles (where one pound mole = 379.41 cubic feet @ 60°F and 14.7 psia).
- R = 10.735 universal gas constant for above units.

Solving for gas content;

$$Volume(mscf) = \frac{(0.03533)PV}{ZT}$$

**F. Calculation of effective gas content using the simple gas material balance and hysteresis curve(P/Z curve) methods**

1. Pressure changes with rapid gas injection or withdrawal during selected operating periods can show the relationship between effective gas content and the storage inventory. Effective gas content is the gas which, within a given time, causes a measurable pressure response to injection or withdrawal operations. Not all gas in the reservoir yields such a response within the given time interval. The difference between

effective gas content at a given pressure ( $P_1$ ) and the metered inventory is non-effective gas. Part of this non-effective gas can be due to the lack of pressure equilibrium within the reservoir. Any gas migration out of the storage reservoir also contributes to the non-effective gas. Either one of the two equations, or the graphical solutions presented below are used to calculate the effective gas content.

- a. Calculations with negligible water movement are made using the following equation:

$$\text{Effective Gas Content at } P_1, Q_1 = \left( \frac{\Delta Q}{\frac{P_1}{Z_1} - \frac{P_2}{Z_2}} \right) \left( \frac{P_1}{Z_1} \right)$$

Where:

$P_1$  = Pressure at the first operational point considered.

$P_2$  = Pressure at the second operational point considered.

$Q_1$  = Net storage volume at the first operational point considered.

$\Delta Q$  = The net change in gas inventory between the two operational points considered.

- b. Calculations with significant water movement of a known rate are made using the following equations:

$$Q_1 = \left( \Delta Q - \left( W_e \times \frac{P_2}{14.7} \times \frac{520}{T_R} \times \frac{1}{Z_R} \right) \right) \frac{\frac{P_1}{Z_1}}{\left( \frac{P_1}{Z_1} - \frac{P_2}{Z_2} \right)}$$

Where terms are defined as above, and where:

$W_e$  = Water influx in cubic feet.

$T_R$  = Reservoir temperature, degrees Rankin.

$Z_R$  =  $Z$  at  $T_R$  and  $P_2$ .

G. Graphical solutions

1. The hysteresis curve is a plot of reservoir pressure versus storage inventory. This curve utilizes the compressibility factor of non-ideal gas.

It is most effective in a constant volume reservoir since it assumes no water movement into or away from the storage reservoir; and no movement of gas into or out of solution in the reservoir oil. Actually, after sufficient storage history, the hysteresis curve becomes a qualitative tool for inventory verification since with constant operating procedures and a relatively constant storage cycling volume, aquifer movement and movement of gas into and out of solution is relatively constant and effectively drops from the equation.

## **VII. REPORTING GAS INVENTORY LOSSES**

### **A. Calculated operational losses**

1. Gas losses due to compressor, piping system or well blowdowns and wireline surveys are calculated by Storage Field personnel and reported to Measurement monthly. These reports are review by the Storage Field Engineer.
2. Estimates of losses related to workovers and well blowdowns are prepared by the Storage Field Engineer after a well has been killed. These estimated losses are reported monthly to Gas Measurement.

### **B. Losses from known well and surface facility leaks**

1. Some small losses from valves, compressors, field piping, threaded well casing connections and well casing mechanical devices such as cementing stage collars, and some small casing leaks are inherent to Storage Field Operations. These leaks are estimated and reported as follows:
  - a. Minor surface facility leakage is surveyed in each storage field periodically. Leakage surveys include wellhead valves and fittings, instrumentation, well piping, field piping, surface production facilities and the compressor station. Surveys are made more frequently if facility modifications are made which might change leakage rates.
  - b. During these surveys, measurements are obtained on representative minor atmospheric leaks and then extrapolated to an estimated annual leakage rate for the field.
2. Subsurface leakage from wells is estimated by the Storage Field Engineer and reported to Storage Engineering Staff.
  - a. Leakage from well casings is estimated by establishing a leakage rate using the radioactive tracer survey. The number of days of leakage is estimated by using subsurface temperature survey data. Casing shoe or Water Shut-Off (WSO) leakage is estimated by reviewing temperature, noise and radioactive tracer

surveys, pressure draw-down and the overlying wells' gas production during the time of the leak.

- b. In cases where leakage rates are not quantifiable, an average rate of 30 Mcf/d may be used. Engineering judgment is then applied and an average daily loss rate selected. The number of days the leak was occurring is determined by taking one-half the difference in the number of days between the last normal and the first abnormal temperature survey.
3. Surface facility leakage and subsurface leakage are quantified annually by the Storage Field Engineer who reports the results to the Storage Engineering Manager and Gas Management.

**C. Reservoir losses**

1. Reservoir losses are categorized as those associated with Company-operated wells completed in the storage reservoir and general reservoir losses.
  - a. Losses associated with the Company-operated wells include losses through failures in the cement between the cap rock and well casing. These losses are also known as "shoe leaks," "WSO" leaks and "stage collar" leaks.
  - b. General reservoir losses include losses through abandoned wells or breakdown of some portion of the trapping mechanism. This type of loss is not directly detected by surveys of Company-operated wells in the storage zone.
  - c. Quantification of reservoir losses utilizes industry accepted methods of inventory verification.
2. Reservoir losses are quantified annually by the Storage Field Engineer who reports results to the Storage Engineering Manager and Gas Measurement.

# GAS INVENTORY — MONITORING, VERIFICATION, AND REPORTING

**RECOMMENDED METHOD: 224.070**

| PC DOCS FCD PROFILE SUMMARY                                                                                                                                                                                                               |                                                                |
|-------------------------------------------------------------------------------------------------------------------------------------------------------------------------------------------------------------------------------------------|----------------------------------------------------------------|
| Document Number:                                                                                                                                                                                                                          | 224.070                                                        |
| Document Title:                                                                                                                                                                                                                           | Gas Inventory - Monitoring, Verification and Reporting         |
| Document Category:                                                                                                                                                                                                                        | Recommended Method                                             |
| Document Status:                                                                                                                                                                                                                          | Active                                                         |
| If Merged, Merged to:                                                                                                                                                                                                                     |                                                                |
| Effective Date:                                                                                                                                                                                                                           | 2/5/1999                                                       |
| Current Version Issued:                                                                                                                                                                                                                   | 2/5/1999                                                       |
| Review Date:                                                                                                                                                                                                                              | 2/5/2004                                                       |
| Prior Numbers:                                                                                                                                                                                                                            | 224.0050; 224.0045; 224.020                                    |
| Company:                                                                                                                                                                                                                                  | Southern California Gas Company                                |
| Business Unit:                                                                                                                                                                                                                            | SCG Energy Transportation Services                             |
| Business Organization:                                                                                                                                                                                                                    | Transmission & Storage Operations                              |
| Department:                                                                                                                                                                                                                               | Storage                                                        |
| Department Organization:                                                                                                                                                                                                                  | Storage Engineering                                            |
| Organization Team:                                                                                                                                                                                                                        | None                                                           |
| Contact Person/Writer:                                                                                                                                                                                                                    | Dan Neville                                                    |
| Referenced Documents:                                                                                                                                                                                                                     | 224.0020; 224.0035; 224.0025; 224.001                          |
| Related Documents:                                                                                                                                                                                                                        |                                                                |
| Part of O&M Plan:                                                                                                                                                                                                                         | No                                                             |
| Compliance Required by:                                                                                                                                                                                                                   |                                                                |
| Mandated by:                                                                                                                                                                                                                              |                                                                |
| CPUC Review Required:                                                                                                                                                                                                                     | No                                                             |
| Legal Review Required:                                                                                                                                                                                                                    | No                                                             |
| <b>Author's Brief/Summary of Changes:</b>                                                                                                                                                                                                 |                                                                |
| This FCD was revised by the Storage Engineer Peer Team. The title of the FCD was changed to Gas Inventory - Monitoring, Verification, and Reporting. It was merged with FCD 224.0045 and FCD 224.020 and changed to a Recommended Method. |                                                                |
| <b>Circulation Code</b>                                                                                                                                                                                                                   | <b>Filing Instructions</b>                                     |
| TRAN                                                                                                                                                                                                                                      | File numerically in Volume II, behind Underground Storage Tab. |
|                                                                                                                                                                                                                                           |                                                                |

SPE Paper

**83504**

# **Environmental Hazards Posed By The Los Angeles Basin Urban Oilfields: An Historical Perspective Of Lessons Learned**

Bernard Endres

*Petroleum Environmental Consultant, Los Angeles, California.*

George V. Chilingar

*Professor of Environmental and Petroleum Engineering  
School of Engineering, University of Southern California*



Presented on May 22, 2003

2003 Combined Meeting  
Long Beach, California  
Technical Session May 21-23

Pacific Section  
American Association of Petroleum Geologists

Western Region  
Society of Petroleum Engineers

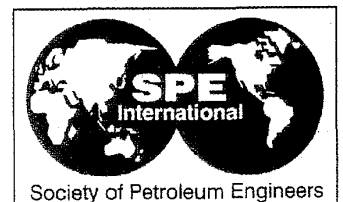





## Environmental Hazards Posed By The Los Angeles Basin Urban Oilfields: An Historical Perspective Of Lessons Learned

Bernard Endres, Petroleum Environmental Consultant, Los Angeles, California.

George V. Chilingar, Professor of Environmental and Petroleum Engineering, School of Engineering, University of Southern California

### Abstract

Urban encroachment into areas historically reserved for oil and gas field operations is an ever-present problem within the Los Angeles basin. The recent frenzy in real estate development has only intensified what can be characterized as a conflict in land usage. Subsurface mineral rights are severed from surface ownership, often resulting in developments being approved without adequate consideration of the underlying oil and gas field consequences. Also, surface operations are frequently co-located within residential areas without consideration of the health and safety consequences of emissions of toxics to air.

This paper presents a review of the environmental, health and safety hazards posed by urban oilfield operations, with an emphasis upon the lessons learned from the "L.A. Basin: Original Urban Oilfield Legend." The Los Angeles basin has provided the authors with one of the largest natural laboratories in the world for studying the consequences of these issues. The results presented are part of a long-term research program based upon the application of geoscience and petroleum engineering principles in obtaining a fundamental understanding of the root causes of the environmental hazards posed. Topics addressed include: (1) vertical migration of gas to the surface along faults and improperly completed or abandoned wellbores (e.g., due to poor cementing practices), (2) subsidence caused by fluid production and declining reservoir pressures, (3) soil and groundwater contamination resulting from historic oil and gas field operations, and (4) air toxics resulting from surface operations.

A number of case histories are discussed that illustrate the seriousness of the problem. A clear case is made for the urgent need for closer coordination and education by the petroleum industry of the local government planning departments. These departments have the principal role in determining land use policies, acting as the lead agency in performing environmental site assessments (e.g., under the California Environmental Quality Act), and in establishing mitigation measures for dealing with the long-term environmental hazards. This paper establishes prudent

practices on the part of oilfield operators for the monitoring and mitigation of these hazards.

### Introduction

The primary purpose of this paper is to systematically review a long history of environmental problems that were created by placing intense urban development in the pathway of areas historically reserved for oil and gas production within the Los Angeles basin. It was during this time that environmental laws were in a state of evolution and the geotechnical impacts of the oilfield operations were not well understood by the land developers. This paper provides a detailed insight into these environmental hazards, along with lessons learned in what mitigation and monitoring methods must be employed in order to prevent repeat disasters. Finally, these findings are related to what must be done to carry out prudent oilfield operations in an urban setting.

Four aspects of environmental hazards posed by oilfield operations within the Los Angeles basin are addressed:

- 1) Upward migration of oilfield gases into the near surface urban environment, largely along faults and improperly completed or abandoned wellbores.
- 2) Subsidence caused by fluid withdrawal and declining reservoir pressures.
- 3) The release of air toxics from surface operations, wellheads and pipelines.
- 4) Soil and groundwater contamination from fluid production and storage tank leaks.

The environmental impacts are regional in nature and require careful planning by governmental agencies, including land planners, to address the full extent of the environmental impacts. Most cities have no expertise in addressing these oilfield environmental hazards, but are routinely granting building permits for development over and adjacent to oilfield operations. For example, the city is usually designated as the lead agency in performing the environmental reviews mandated by the California Environmental Quality Act (CEQA). However, without adequate knowledge of the oilfield environmental hazards, urban developments are approved without protections taken against the risks.

**Gas Migration in Oilfield Settings.** The Los Angeles basin has been plagued with numerous oilfield gas seeps that continue to present serious explosion and health risks to the residents. Oilfield gases have a propensity to migrate to the surface along faults and poorly completed and/or abandoned wellbores. Furthermore, the upward migrating gases will accumulate in near surface collector zones, often trapped and concealed within permeable gravel and sand lenses.

The lower explosive limit (LEL) of the oilfield gases (composed primarily of methane) is approximately 5% by volume when mixed with 95% by volume of air. This translates into a serious explosion and fire hazard, especially where the gas is capable of migrating into a confined space such as a room or an electrical vault. In the Los Angeles basin many homes and commercial structures have been constructed directly over old oil wells that have not been properly sealed, and no mitigation measures have been taken to seal out the seeping gases.

#### **The March 24, 1985 Ross Department Store Explosion.**

The first clear recognition of a very serious problem with oilfield gases migrating to the surface and causing an explosion hazard was the March 24, 1985 incident in the Fairfax area of Los Angeles which demolished the Ross Department Store and injured over 23 people (Cobarrubias, 1985). Escaping oilfield gases burned for days through cracks in the sidewalks and within the parking lot surrounding the store located at 3<sup>rd</sup> Street and Ogden Drive, directly across the street from the Farmer's Market. Also, large quantities of gas were detected migrating to the surface under the Hancock Park Elementary School located on Fairfax Street near 3<sup>rd</sup> Street.

Near-surface soil gas studies revealed that the highest concentrations of gases were aligned in an elliptical pattern with the semi-major axis having an exact alignment with the Metropolitan Number 5 Slant Well operated from a nearby drilling island. A review of production records revealed that this well consistently produced the largest gas volumes of any operational well from the underlying Salt Lake Oilfield. Eventually, well records were obtained that revealed that the well casing had developed leaks as a result of corrosion holes located at a depth beginning at approximately 1200 feet, and extending deeper (Endres, 1991; Khilyuk et al., 2000).

Gas pathways to the surface included the 3<sup>rd</sup> Street Fault (see Figure 1), that surfaced at the Ross Store location, and an old abandoned vertical well identified on the Division of Oil and Gas map for the area as Well Number 99. A vent well drilled into the parking lot of the Ross Store discovered a large pocket (collector zone) of trapped oilfield gas at a depth of approximately fifty (50) feet (see Figure 2). This collector zone had sufficient porosity and permeability to serve as a temporary trapping mechanism for the large quantities of upward migrating gases from the leaking wells to build to pressures of approximately 25 pounds per square inch of pressure. A clay layer served as a trapping mechanism until its threshold pressure was exceeded. Permanent soil gas probes were installed to a depth of approximately fifteen (15) feet in order to perform ongoing monitoring of the upward migrating gases (see Figure 3).

Detailed gas fingerprinting, primarily utilizing isotopic gas characterization, was instrumental in providing 100%

scientific proof (see Figure 4) that the explosion and fire was caused by the underlying Salt Lake Oilfield operations (Schoell et al., 1993). Also, further investigation revealed that the gas seeps at the nearby La Brea Tar Pits result from upward migration of oilfield gases from the Salt Lake Oilfield along the 6<sup>th</sup> Street Fault (Jenden, 1985). The 6<sup>th</sup> Street Fault slopes downward to the north and intercepts the oilfield reservoir at the location of the Metropolitan Number 5 Production Zone (viz., a very prolific gas zone). Gas fingerprinting has confirmed that the gas seeps at the La Brea Tar Pits match the leaking gases that caused the Ross Department Store explosion (Jenden, 1985).

**The City of Los Angeles Methane Ordinance.** Following the Fairfax explosion and fires in 1985, the City of Los Angeles adopted a methane ordinance that was incorporated into the City of Los Angeles Building Code, Chapter 15, titled "Methane Seepage District Regulations." The stated purpose is for control of methane intrusion emanating from petroliferous formations. These regulations apply largely to new construction, the boundaries of which are defined in the code, but are coincident with the boundaries of the Salt Lake Oilfield.

Existing commercial structures, including the Hancock Park Elementary School, were required to install gas detectors. These requirements for gas detection in existing buildings, however, were limited to the commercial buildings in the immediate vicinity of the Third Street and Ogden explosion site. Additionally, these commercial establishments were required to share the weekly monitoring expenses associated with the permanent soil gas probes that are depicted in Figure 3. Unfortunately, the Anthony No. 1 gas well (see Figures 2 and 3), that was installed to vent gas from the underlying formation, became plugged in the 1989 time period. Namely, the weekly monitoring of the soil probes failed to provide advanced warning of a near disaster on February 7, 1989.

**The Near Disaster of February 7, 1989.** On the morning of February 7, 1989, a pedestrian who was walking by the Gilmore Bank building, located on the north side of Third Street and across the street from the 1985 explosion site, observed gas bubbling through the ground in a planter box. The Fire Department was called, which led to the discovery of area wide gas seeps emerging from below the sidewalks and streets, a near repeat of the 1985 incident, but without an explosion.

It was discovered that the Anthony vent well had become silted and plugged at the perforated intervals of the permeable sand zone depicted in Figure 2. This condition was aggravated by the ground water conditions existing at the depth of the vent well.

The response team soon recognized similarities to the 1985 explosion and fires, and the area was immediately cordoned off to prevent ignition and explosion of the gas. In the wake of this near disaster, the City of Los Angeles undertook a second task force study. Unfortunately, even in the presence of overwhelming scientific evidence that the gas accumulations were the direct result of ongoing oil and gas production, and leaking oil wells (see Figure 1), the City of Los Angeles has stood steadfast on the theory that the most

probable source of the methane gas was not an oil well, but rather decomposing organic matter near the surface.

The State Department of Conservation, Division of Oil, Gas, and Geothermal Resources (DOGGR) has also stood steadfast on the proposition that the gas did not originate from the underlying Salt Lake Oilfield, or from leaking wells. Unfortunately, for public safety, this is contradicted by their own well records that clearly demonstrate that the Metropolitan No. 5 well (see Figure 1) had developed serious corrosion leaks within the well casing. These leaks were ongoing, and caused large quantities of oilfield gases to leak into secondary collector zones below both the explosion site and under the Hancock Park Elementary School.

Extensive scientific testing has confirmed that the migrating gases contain methane, ethane, propane, butane and trace elements that could only have an oilfield origin. Accordingly, it is scientifically impossible for these gases to have originated from decomposing organic matter near the surface. Neither the City nor the State has been willing to reconcile their claims with the scientific data substantiated by the top gas fingerprinting experts in the world (Schoell et al., 1993; Jenden, 1985). Figure 4 shows the match between the field production gases and the gas from seeps at the surface.

There is an increased risk of a similar incident occurring somewhere else within our approximately 70 oilfields within the Los Angeles basin. The most important lesson to be learned from the Fairfax explosion is the need to carefully evaluate the integrity of the many old oil wells in the Los Angeles basin that can serve as the primary source and/or the pathways for the oilfield gases to migrate to the surface. The authors have confirmed this enormous hazard by evaluating hundreds of documented well leaks, and identifying the causes of the leaks. Virtually all well leaks can be traced to poor well completion and/or abandonment procedures (e.g., poor cementing practices).

#### **The Well Leakage Problem as an Environmental Hazard.**

Wells that were drilled and completed many years ago are subject to ongoing corrosion and deterioration of both the steel casings and the cementing operations.

Gas intrusion into cemented wellbores and the resultant leakage to the surface and porous formations below the wellhead have been persistent problems in the oil and gas industry for many years (Marlow, 1989). Pressure and temperature cycling on the cement bonding characteristics, an acute problem in the gas storage industry, can give rise to shoe leaks and loss of bonding in the annular cement. To help quantify the annular leakage problem in gas storage wells, a survey was prepared and sent to the members of the American Gas Association's Pipeline Research and Storage Reservoir Supervisory Committees. The survey attempted to determine the magnitude of the annular leakage problem.

Tests showed that even when the most up-to-date cement types and techniques are used, leakage can and will occur in a significant number of cases (Marlow, 1989 at pp 1147, 1148). For example, in a study of 250 casing jobs over a 15-month period with new compressible cements, 15% of the wells leaked (Watters et al., 1980). Accordingly, the poor cementing and completion practices, typical of the many old wells located in the Los Angeles basin, are giving rise to very

serious environmental problems associated with gas leakage to the surface in the annular space, as discussed herein.

Numerous fields have accumulations of hydrogen sulfide that will eventually destroy the integrity of both the steel and cement relied upon to provide protection against gas migration, including abandonments performed to the current standards of the DOGGR. The corrosive conditions of hydrogen sulfide are well known, and have defied engineering solutions (Craig, 1993).

Ongoing seismic activity in the Los Angeles basin is also a major factor in contributing to a well integrity problem. For example, the 1971 Sylmar earthquake was responsible for causing well blowouts in the Fairfax (Salt Lake oilfield) area (Khilyuk, et al., 2000).

**Wilshire and Curson Gas Seep.** A very serious gas seep at the intersection of Wilshire and Curson (directly across the street, and south of the La Brea Tar Pits) was discovered in 1999. This required the City of Los Angeles to install a vent pipe on the south-west corner of this intersection in order to direct the oilfield gases into the air above the adjoining three story commercial building. The odors from the air toxics emitted from the vent pipe are noticeable throughout the area.

The commercial office building to the immediate east of this seep location was experiencing gas migration through the foundation and into the building. A ventilation system is operated 24 hours per day within the subterranean parking structure of that building in order to mitigate against the risk of an explosion.

Historical records of the area, reviewed by the authors herein, revealed that an old abandoned well had been drilled near the location of the seep. However, the high-density commercial development in the area has prevented finding the well.

**South Salt Lake Oilfield Gas Seeps From Gas Injection.** In January 2003, serious gas leakage problems were discovered in the South Salt Lake Oilfield, located in a residential area near the Fairfax area (viz., in the vicinity of Allendale and Olympic Boulevard). The oilfield operator had been injecting natural gas into the South Salt Lake Oilfield for approximately two years, under elevated pressures for enhanced oilfield recovery purposes. However, gas began leaking to the surface along abandoned and poorly completed wellbores. In fact, the Division of Oil and Gas records reveal that numerous wells were drilled before official records were maintained. Accordingly, the existence and abandonment status of some of these wells is unknown. High-density urban development, largely of apartment buildings has occurred directly over many of the old wells.

The oilfield is operated through slant wells. The residents of the area had no warning or any indication of the hazards posed by the leaking old wells. The prior history of the Ross Department Store explosion, the numerous gas seeps in the area, and a long-standing problem with oil well leaks should have placed the decision makers on notice of the irresponsible risk taking of injecting gas under high pressure into the formation.

**Montebello Underground Gas Storage Operations.** The partially depleted Montebello Oilfield was converted into an underground gas storage operation. Natural gas was transported into the field through interstate pipelines and injected under high pressure (exceeding 1500 pounds per square inch) into the 8<sup>th</sup> Zone located at a reservoir depth of approximately 7,500 feet. However, storage gas was discovered leaking to the surface along old wellbores that had been drilled in the 1930's era. In some instances, homes had to be abandoned and torn down in order to provide access to drilling rigs in an attempt to repair and/or reabandon old wells. Studies revealed that the well cementing operations, the cement plugs used in well abandonment and the integrity of the well casings were not adequate to seal off the high pressure storage gas from migrating along the wellbores to the surface. This facility had to be abandoned because of the gas leaks. However, it will take many years to deplete the gas to pre-storage conditions.

These examples indicate the importance of a systematic examination of how wells leak, and the dangers posed by allowing residential construction to occur directly over old wells. On the other hand, if each well leak is evaluated in isolation of the long history of problems in this area, the true dangers will not be recognized.

**Playa Del Rey Underground Gas Storage Operations.** The Playa del Rey Oilfield, located in the Marina del Rey area of the Los Angeles basin, was converted to an underground gas storage operation in the 1942 time period, and has been operated in that manner ever since. The Venice Oilfield adjoins the area to the immediate north. The gas storage reservoir has been leaking into the adjoining Venice Oilfield since the early years of operation (Riegle, 1953). There are over 200 old and abandoned wells throughout this area, including wells that had to be specially abandoned in order to accommodate the construction of the Marina del Rey Boat Harbor (see Figure 5). For example, some old wells are located directly below the main channel that connects to the Pacific Ocean. Numerous gas seeps have been observed by the authors of this paper within the boat harbor, and within the Ballona Flood Control Channel that bisects the area and extends eastward along the old Los Angeles Riverbed alignment.

The Los Angeles River was responsible for depositing a massive gravel layer that extends eastward providing a highly permeable zone for leaking oilfield gases to collect and migrate easterly, including under the influence of tidal forces. The gravel zone begins (viz., below surface sediments) at a depth of approximately 50 feet (referred to as the "50 ft. Gravel") and extends to a depth of several hundred feet. This gravel zone is interconnected with many of the old wells in the area, and serves to conceal the identity of wells that are experiencing the worst leakage. However, gas fingerprinting has established that the leaking well gases match the gases seeping to the surface along the flood control channel and into the surrounding residential areas.

This gravel zone has been determined to be saturated with large quantities of oilfield gases, which becomes additionally pressurized during heavy rains as a result of the shallow aquifer being recharged. Surface gas seeps become very pronounced because of this pressurization, and can be

observed bubbling through standing water during such rains. Probes placed into the 50 ft. Gravel Zone have measured gas flow rates as high as 20 to 30 liters per minute. Also, drilling rigs have experienced well blowouts as a result of encountering the high-pressure gas zone when penetrating to 50 feet.

These examples, including the Ross Department Store explosion and vent well histories, reveal the importance of understanding the underlying hydrology in the identification of hazardous oilfield gas seeps to the surface (also see Toth, 1996). These studies have confirmed that the water table and the underlying permeable aquifers can act to conceal the true magnitude of the gas migration hazards. Accordingly, soil gas studies must include the magnitude of the free and dissolved oilfield gases contained in the near surface aquifers. This may include multiple zones, requiring the use of deep soil probes determined by first characterizing the underlying hydrology of the site.

A review of well abandonment records for the Playa del Rey and Venice oilfields has revealed very serious leakage problems. Leakage within the annular space between the casing and drill hole, because of poor cementing (see above), is a serious problem. Most of the wells depicted in Figure 5 were drilled in the 1930's, before prudent cementing practices were even used. For example, wells that had been abandoned as recently as 1993 — in order to make way for housing developments — were found to be leaking when excavations were begun for the actual construction. In each case, homes were constructed directly over the old wells after minimal efforts were taken in an attempt to reseal the wells. Because of the small lots and high-density construction, there will be no room for reaccessing the wells using conventional drilling rigs.

Most of the construction in the Playa del Rey and Venice oilfield areas has failed to provide gas detection or other mitigation measures (e.g., as required by the Methane Ordinance) in order to deal with these gas migration hazards. For example, the underground gas storage operations at Playa del Rey continue to inject storage gas under high pressure (approximately 1700 pounds per square inch). Gas storage and inventory studies (Tek, 1987) have shown that leakage is directly proportional to the reservoir pressure maintained for gas storage (see Figure 6). This raises serious questions about the appropriateness of locating gas storage fields in highly populated urban settings, especially where many homes have been built directly over poorly abandoned wells. It is paramount that a fundamental understanding of how wells leak and proper procedures for monitoring are developed. Gas storage pressures are typically selected by the gas storage operator to maximize the storage volume, and to enhance retrievability of the gas when market demands dictate recovery (usually during cold spells when usage suddenly skyrockets). Also, cyclic operations associated with gas injection and withdrawal may create conditions conducive to the formation of leaks.

**Hutchinson, Kansas Gas Storage Leaks, Explosions And Fires of January 17-18, 2001.** Underground gas storage leaks caused a devastating explosion and fires in the downtown area of Hutchinson, Kansas on January 17, 2001 (Allison, 2001). A sudden release of natural gas burst from the ground under

several stores. Upon ignition windows were blown out, and within minutes two businesses were ablaze. The Fire Department was unable to extinguish the flames because of the ongoing migration of gas into the area.

On the following day, leaking gas migrated into a trailer park on the outskirts of the town, causing a second explosion, and killing two people. The gas leakage was traced to a leaking storage gas well nearly seven miles from the town. The grim reminder is the similar circumstances that gave rise to the Fairfax explosion (viz., directly traceable to the same type of well leakage problem), and the hazards posed by underground gas storage in an urban area. At Playa del Rey, many homes have been constructed directly over old oil wells that directly interconnect with the high-pressure storage gas that is maintained at approximately 1700 pounds per square inch. The conflicting land use of such activities has to be seriously questioned, especially in view of the high risks posed by old and poorly maintained wells, most of which are no longer accessible because of construction.

Santa Fe Springs Oilfield. A study was undertaken by the authors to determine the integrity of operational oil wells in the Santa Fe Springs oilfield. In order to facilitate this review a time period was selected after heavy rains in which the well cellars had partially filled with water. This allowed observation of gas bubbles seeping to the surface along well casings. Results were systematically recorded across the operation of more than 50 wells, some of which were being used for water flooding operations at pressures approaching 1200 pounds per square inch. Approximately 75% of the wells were found to be leaking oilfield gas to the surface.

An important conclusion reached was that water flooding for enhanced oilfield recovery can be a dangerous practice, especially in an urban setting where gas could migrate to the surface creating an explosion hazard. Pressurization of an oilfield by way of water injection or gas injection (see South Salt Lake Oilfield example in this paper) requires careful attention to the integrity of the wells throughout the oilfield, and should not be undertaken until an ongoing soil gas monitoring program has been implemented in the vicinity of each well to detect the potential leakage of oilfield gas to the surface. This is also necessary to determine the need for well repairs and/or well abandonment.

**Belmont School Construction on An Oil Field.** The Belmont Learning Center, a proposed high school in downtown Los Angeles, was in the process of being constructed over the Los Angeles City Oil Field before being abandoned. The site chosen was on a 35-acre parcel of land bounded by 1<sup>st</sup> Street to the south, Temple Street to the north and Beaudry to the east. This location is situated over a shallow oil field that has an outcrop to the surface just north of the building site. Furthermore, major faults criss-cross the area as illustrated in Figure 7 (California Division of Oil and Gas, 1991). The area is also part of the Elysian Park blind thrust fault system that has a generally east-west trend that helps explain the uplifting and tilting of petroliferous formation depicted in Figure 7.

Oil wells in the area continue to produce from shallow oil deposits at a depth no greater than 700 feet. Most of the wells were drilled in the early 1900's, and continue to produce using archaic drilling and production practices. For example, all of the oil field production gases are released to the atmosphere in

the residential areas surrounding the well production. This includes four operational wells located on the northwest corner of the school property.

Environmental studies, undertaken only after construction was undertaken, has revealed oilfield gas seepage to the surface over most of the 35 acre parcel, including the area directly under the school buildings. The project was abruptly halted when gas seepage was detected in the main electrical vault room of the project, just before the power was to be energized.

Soil gas studies revealed that explosive levels of methane and other oilfield gases were migrating to the surface, including hydrogen sulfide. Measurements at the well head, and at other seep locations, revealed releases to the air of over 300 parts per million (ppm) of hydrogen sulfide. At depth, hydrogen sulfide was measured at over 3000 ppm. These alarming results were extensively evaluated by the authors herein, and commented on during the many environmental reviews for the project (Endres, 1999; Endres, 2002).

Over 175 million dollars have been spent on the project by the Los Angeles Unified School District. At least 20 million dollars have been spent on environmental site characterization alone. Most of this expenditure has been driven by an attempt to find a solution to the myriad of oilfield problems created by the site selection process. For example, a double passive membrane has been proposed to be installed over the entire 35-acre site.

A recent discovery of surface faulting extending under several of the school buildings has placed a further halt on construction, and may doom the entire project.

This case history clearly identifies the extreme caution needed in evaluating the environmental suitability of sites located over oilfields, especially for school construction. The State of California has passed recent legislation that requires direct participation by the Department of Toxic Substances Control (DTSC) in the future school site selection process in order to avoid a repeat of the Belmont fiasco.

#### **Subsidence Problems Caused By Oilfield Fluid Production.**

One of the most serious environmental problems caused by oilfield operations within the Los Angeles basin has been subsidence (Chilingarian, et al., 1995 and 1996). Subsidence exists in virtually every oilfield within the Los Angeles basin (Wentworth, et al., 1969). Subsidence is caused by the reduction of pore pressure within the reservoir resulting from fluids production. This influence is propagated to the surface resulting typically in a bowl shaped recession at the surface, centered over the oilfield (see Figure 8). The subsidence can typically extend to an area approximately twice the geometric size of the oilfield itself (Khilyuk, et al. 2001). The enormity of the problem is well known for the Wilmington Oilfield that reached approximately 28 feet before corrective action was taken by implementing a massive and ongoing water injection program. This required legislative action in order to bring about a unitization of the oilfield to allow the water-flooding program to be implemented. It has also become the public policy of this State to arrest subsidence, especially in coastal areas, through the use of water injection.

Minimizing the consequences of subsidence requires implementing a subsidence-monitoring program. The standard in use today in oilfields throughout the world

(Endres, et al. 1991) is the Global Positioning Satellite System (GPS). The disasters of the past can be directly traced to the failure to perform adequate ongoing monitoring for subsidence. Namely, where conventional surveying, and now satellite geodesy, permits determination of vertical and horizontal movements of the land surface above oilfields with great accuracy and at relatively minimal cost.

**The Baldwin Hills Reservoir Failure of 1963.** On December 14, 1963, at about 11:15 a.m., an unprecedented flow of water was heard in the spillway pipe at Baldwin Hills Dam in the Inglewood Oilfield area of Los Angeles. A short time later water broke violently through the downstream face of the dam causing massive property damage to homes located below the dam and five deaths. The owner, the Los Angeles Department of Water and Power, had operated the dam continuously from July 1951 until its failure on December 14, 1963. Although an ongoing surveillance for leaks within spillways was carried out, no monitoring for oilfield subsidence was undertaken.

The Inglewood Oilfield, discovered in September 1924, lies under the western half of the Baldwin Hills area. It covers about 1200 acres and in 1963 had more than 600 producing wells (see Figure 9). The field adjoins the reservoir site on the south and west, the nearest reported production at the time of the reservoir failure being from three wells within 700 feet of the south rim.

Analysis of failure revealed ground movement that correlated directly with the Inglewood Oilfield fluid production (see Figure 10). The total area of subsidence resembled an elliptical bowl with its center about 0.5 miles west of the reservoir and centered over the oilfield. Subsidence at the reservoir site aggregated about 3 feet, compared to nearly 11 feet at the subsidence bowl. Noteworthy, was the fact that the southwest corner (viz., direction of maximum subsidence) had dropped more than the northeast corner, resulting in differential settlement across the dam of approximately 0.5 foot. Furthermore, a review of survey data from 1934, 1961 and 1963 showed lateral movement in the direction of the subsidence depression.

The Inglewood-Newport Beach active strike-slip fault also bisects the area (see Figure 9), with numerous faults branching off of the main fault in the area. Oilfield drilling records clearly reveal these many branching faults, indicating the enormous potential for differential movement along individual fault blocks. Indeed, a post-accident investigation revealed that differential fault block movement had caused rupturing of the asphaltic membrane used as a water seal over the floor of the dam.

Although fluid extraction and resultant subsidence were the prime contributors to the rupture of the reservoir, there is substantial evidence to indicate that fluid injection to stimulate oil production was also a contributing factor (Hamilton et al., 1971). Increased fluid pressures in the reservoir resulting from secondary recovery from water injection were sufficient to force brine water to the surface along faults. These forces, along with the lubricating influence of the water exacerbated differential movement along individual fault blocks.

Recently, a large housing development was proposed for the Baldwin Hills area, virtually over the above described subsidence area. Large retaining walls (exceptionally high) were contemplated to enhance views (and presumably to add

value to the individual lots). These retaining walls would have been extremely vulnerable to this geologically active and subsidence prone area. When the developer became aware of the history of land movement in the area from ongoing oilfield production, the property was willingly sold to the State for use as a public park.

This case history highlights the importance of proper planning and monitoring involving land movement in an area that has been heavily impacted by major faulting, oilfield subsidence, and secondary oilfield recovery.

**Redondo Beach, King Harbor Subsidence.** During a winter storm in January 1988, waves overtopped the breakwater constructed by the U.S. Army Corps of Engineers in order to protect the Redondo Beach King Harbor Boat Marina and surrounding commercial structures. Enormous damage resulted, including the destruction of the Portofino Inn. King Harbor is located at the northwest end of the Torrance Oil Field, and is directly over the Redondo Beach Oilfield (which is considered an extension of the Torrance Oilfield). The City of Redondo Beach had granted permission for offshore drilling from slant wells located in that city.

Benchmarks used by the U.S. Army Corps of Engineers to construct the breakwater height were based on a U.S. Coast and Geodetic Survey of 1945. These benchmarks were assumed fixed, since the Corps did not suspect subsidence until 1985, when surveys showed the breakwater crests to be as much as 2 to 3 feet above original design elevations. However, nothing was done to protect the harbor, or to warn the commercial establishments prior to the storm of January 1988.

Investigation following the disaster revealed that nearly 2 feet of subsidence had occurred under the breakwater as a result of oil production beginning in 1943, but with accelerated subsidence occurring following the approval of tideland oil production in 1956.

A jury trial in the Torrance Superior Court resulted in a multi-million dollar judgment against the U.S. Army Corps of Engineers and the City of Redondo Beach. Several oil companies involved in the oil production settled prior to the case going to trial.

The main lesson to be learned is that this disaster could have been averted if proper monitoring for subsidence had been undertaken. It is important to note that the judgment was upheld on appeal, in which the Appellate Court found that undertaking oilfield production in such an urban setting constituted an ultra hazardous activity, requiring the utmost standard of care. Virtually every oilfield in the Los Angeles basin has experienced subsidence as a result of fluid production. Accordingly, an appropriate standard of care for all oilfield operators should be to undertake monitoring from the onset of production.

**Playa Del Rey/Marina Del Rey Subsidence.** Historical measurement data regarding subsidence in the Playa del Rey/Venice oilfield areas reveal almost 2 feet of subsidence between the time that oil production began in the 1920's and through 1970. However, no subsidence monitoring has occurred since 1970, despite the fact that fluid production has continued to the present. The Marina del Rey breakwater is

vulnerable to this subsidence, as is the coastal area from storm flooding.

An additional threat is from oil well damage and movement along fault blocks resulting from subsidence. The most vulnerable are the old wells that were drilled and completed in the 1930's. Any damage to the well seals and/or geological movement along fault blocks present the potential for increased gas migration to the surface. This is especially critical since the oilfields underlying the area are being used to store high-pressure gas transported in from out of state. Figure 11 is presented to illustrate the interaction between gas migration and subsidence resulting from oilfield fluid production (Chilingarian et al., 1995; Gurevich et al., 1993).

Clearly, these oilfield operations constitute ultra hazardous activities, requiring the utmost degree of vigilance in order to protect the high-density urban development in the area. Monitoring for subsidence and gas migration is essential in order to meet this standard of care.

**The Release of Air Toxics From Surface Operations, Wellheads And Pipelines.** The Federal Environmental Protection Agency (EPA) has determined that the primary hazardous air pollutants (HAP) emitted from oil and natural gas transmission and storage facilities are (see Federal Register, Volume 63, No.25/Feb.6,1998):

- 1) Benzene
- 2) Toluene
- 3) Ethylbenzene
- 4) Mixed Xylenes
- 5) n-Hexane

The first four of these chemicals are collectively referred to as the BTEX chemicals. The BTEX chemicals derive their existence from the aromatic component of crude oil. For a further discussion of these hazardous components of crude oil see McMillen et al., (2001). Although crude oil has variable contents of aromatic hydrocarbons, depending upon the origin, the API rating of the crude oil can be a good predictor of the amount of aromatics, and especially benzene, found in the production stream (see Figure 12). Namely, the higher the API rating of the crude oil, the higher the percentage of aromatics contained within the crude oil.

Tissot and Welte (1978) found that 95% of the crude oils produced around the world fell into the distribution pattern shown in Figure 13. As an example, the composition of a 35° API-gravity crude oil was reported by Hunt (1979) to contain the following distribution:

| <u>Molecular Type</u> | <u>Weight Percent</u> |
|-----------------------|-----------------------|
| Paraffins             | 25                    |
| Naphthenes            | 50                    |
| Aromatics             | 17                    |
| Asphaltenes           | 8                     |
| Total                 | 100                   |

The majority of crude oils have been reported to contain 15 to 40% aromatics. The aromatics are characterized by a double carbon bond, which has been directly linked to the health hazards posed by these chemicals. Benzene, a known human carcinogen, has been linked in the medical literature to leukemia, aplastic anemia, lymphomas and a variety of other cancer related ailments.

The American Petroleum Institute (API), as early as September 1948, issued a report authored by P. Drinker titled "API Toxicology Review: Benzene." This report contained the following statement:

"Inasmuch as the body develops no tolerance to benzene and there is a wide variation in individual susceptibility, it is generally considered that the only absolutely safe concentration for benzene is zero."

Oil and gas production facilities are required to provide warnings to the public regarding certain hazardous oilfield chemicals, including benzene and toluene, under California Health and Safety Code Section 25249.6 (otherwise known as Proposition 65). An example of such a warning as posted at an oil production facility located in the Los Angeles basin reads as follows:

DETECTABLE AMOUNTS OF CHEMICALS KNOWN TO THE STATE OF CALIFORNIA TO CAUSE CANCER, BIRTH DEFECTS, OR OTHER REPRODUCTIVE HARM ARE FOUND IN AND AROUND THIS FACILITY.

Most facilities are not required to identify the amount or the specific types of chemicals being released to the atmosphere from their operations. The Federal EPA has identified dehydration equipment as a major source of benzene and toluene air toxics emissions, and has proposed legislation to curtail such emissions, especially in residential areas.

Venting of oilfield gases to the atmosphere must be viewed as a hazardous activity, since the oilfield gases can contain appreciable levels of benzene. Associated oilfield gases and condensates have exhibited the highest levels of benzene. A typical range of benzene in oilfield gases can vary between 30 parts per million (ppm) to over 800 ppm. For this reason, the gas should be carefully tested for its benzene composition before intentional venting of large quantities of gas is undertaken. Also, dehydration vent stack emissions should be carefully monitored.

Prudent oilfield operations dictate that stringent vapor recovery systems be installed to limit VOC emissions to an absolute minimum, especially in populated areas. The BTEX chemicals are highly volatile, and are heavier than air. Accordingly these chemicals will settle to the ground level, and create an inhalation hazard to the surrounding community.

Additional concerns and precautions must be taken in and around sour oilfield operations. Hydrogen sulfide, even in small quantities, can be hazardous to the health. The research conducted at the University of Southern California Medical Facility (Kilburn, 1998; Kilburn, 1999) has established central nervous system damage from the neurotoxin effects of hydrogen sulfide even at levels as low as 1 ppm. This is much lower than the workplace standards that have been considered safe in the past. This also highlights the importance of not relying upon workplace standards regarding air toxics emissions, especially into residential areas and school sites.

This highlights the need to incorporate the full range of potential exposures to human receptors through the multiple sources of toxics emissions. This includes the BTEX and VOC emissions resulting from ground water and/or soil

contamination resulting from the historical oil and gas production facilities.

Safety, health, and environmental considerations need to be made a top priority in the planning and land use planning where urban development coexists with oil and gas field operations. The environmental hazards far exceed earlier expectations.

## Conclusions

The history of the Los Angeles basin oilfields has demonstrated the need to exercise a high degree of vigilance regarding the environmental hazards posed by these operations. Land use planning and governmental entity decisions regarding allowing massive real estate development over and adjacent to these operations have largely ignored the health and safety risks posed by these operations. The primary purpose of this paper has been to show the importance of reviewing a long history of environmental problems created by this mixed land usage, and to identify what steps need to be taken to avert future disasters. This includes the necessity of taking the following steps:

- 1) *Gas Migration Monitoring*: Much closer attention must be given to the need to perform ongoing monitoring for gas migration into the near surface soils in areas heavily impacted by historical oil production, and where there are many old and abandoned wells.
- 2) *Subsidence Monitoring*: Monitoring for subsidence in oil and gas producing areas is necessary in order to protect against the undermining of foundations, highly sensitive changes in elevation (especially in coastal areas), and to reduce the risk of gas migration hazards.
- 3) *Air Toxics Monitoring*: The release of air toxics from surface operations, wellheads and pipelines must be carefully monitored in order to be protective of public health, especially from the release of such chemicals as benzene, toluene, ethylbenzene, xylene (viz., the BTEX aromatic hydrocarbons), hydrogen sulfide, and a plethora of other hazardous chemicals that are known to be released from oil and gas field operations. Greater protection is required in the operation of vapor recovery equipment, and in the monitoring of toxic emissions is order to take corrective action.
- 4) *Soil And Groundwater Monitoring*: Soil and groundwater must be carefully evaluated for petroleum and drilling mud contamination, and appropriate steps must be taken to remediate the soil and water contamination before development is allowed to proceed. This requires an evaluation of the underlying aquifers, which become a ready target for oil and gas migration hazards.
- 5) *Soil Gas Monitoring*: Soil gas monitoring is an essential step in the evaluation of soil and aquifer contamination by historic oil and gas field operations. It is also necessary to determine what mitigation measures may be necessary to protect against migration of explosive and toxic oil field gases into residential and commercial structures. This will be an ongoing problem in many areas that must employ gas detectors, vent pipes, membrane barriers and

ventilation systems in order to protect against the gas migration hazards.

- 6) *Oil And Gas Well Leaks And Ongoing Monitoring*: Oil and gas wells must be carefully evaluated, and old wells must be reabandoned in order to protect against the risk of oilfield gases migrating up the old wellbores and entering the near surface environment. There has been a long history of this very serious problem, establishing that the prior well abandonment procedures have been woefully inadequate in dealing with this extremely dangerous problem.
- 7) *Prohibit Building Over Abandoned Wells*: Homes should not be allowed to be constructed over old wellbores and faults. Furthermore, land planning and issuance of building permits should require adequate room to provide access for a drilling rig to reenter old wells, when they begin leaking.

## References

1. Allison, M.L., 2001. The Hutchinson gas explosions: Unraveling a geologic mystery. *Kansas Bar Association, 26<sup>th</sup> Annual KBA/KIOGA Oil and Gas Law Conference*, vi: 3-1 to 3-29.
2. California Division of Oil and Gas, 1991, *California Oil and Gas Fields*, Vol.2, California Div. Oil and Gas publ. No. TR 12, Sacramento.
3. Castle, R.O. and Yerkes, R.F., 1976, Recent Surface Movements in the Baldwin Hills, Los Angeles County, California – A Study of Surface Deformation Associated with Oil Field Operations: *U.S. Geological Survey Professional Paper 882*, 125 p.
4. Chilingarian, G.V., Donaldson, E.C. and Yen, T.F., 1995. *Subsidence Due to Fluid Withdrawal*, Developments in Petroleum Science, 41, Elsevier, Amsterdam, 498 pp.
5. Chilingar, G.V., Khilyuk, L.F., and Katz, S.A., 1996. Pronounced changes in upward natural gas migration as precursors of major seismic events. *J. Pet. Sci. Eng.*, 14:133-136.
6. Cobarrubias, J.W., et al. (1985) Task force report on the March 24, 1985 methane gas explosion and fire in the Fairfax area, City of Los Angeles, Department of Building and Safety, 58 p.
7. Craig, B.D., 1993. *Sour-Gas Design Considerations*, Society of Petroleum Engineers, Inc., Monograph Volume 15.
8. Denton, J.E., et al., 2001. *Prioritization of Toxic Air Contaminants under the Children's Environmental Health Protection Act*, California Environmental Protection Agency Final Report.
9. Endres, B., 2002. *Why the Belmont Learning Center Requires the Preparation of a Subsequent Environmental Impact Report (EIR)*, Los Angeles Unified School District School Board Hearing, August 15, 2002.
10. Endres, B., Chilingarian, G.V., Pokinwong, P., 2002. *Environmental Hazards and Mitigation Measures for Oil and Gas Field Operations Located in Urban Settings*, Canadian International Petroleum Conference, Calgary, Alberta, Canada, June 13, 2002.
11. Endres, B., 1999. *An Evaluation of the Oil and Gas Migration Hazards Existing at the Belmont Learning Center Complex*, Belmont Blue Ribbon Commission Hearings October 1999.
12. Endres, B.L., Chilingarian, G.V., and Yen, T.F., 1991. Environmental hazards of urban oil field operations. *J.Pet.Sci.Engr.*, 6:95-106.
13. Gurevich, A.E., Endres, B.L., Robertson, Jr., J.O., and Chilingarian, G.V., 1993. Gas migration from oil and gas fields and associated hazards. *J. Pet. Sci. Eng.* 9:233-238.



14. Gurevich, A.E. and Chilingarian, G.V., 1993. Subsidence over producing oil and gas fields, and gas leakage to the surface. *J. Pet. Sci. and Eng.*, 9(3):239-250.
16. Gurevich, A.E., Endres, B.L., Robertson, J.O., and Chilingarian, G.V., 1993. Gas migration from oil and gas fields and associated hazards. *J.Pet.Sci.Engr.*, 9:223-228.
17. Hamilton, D.H., and Meehan, R.L. (1971). Ground Rupture in the Baldwin Hills: *Science*, v.172, p.333-344.
18. Hunt, J.M., 1979. *Petroleum Geochemistry and Geology*, San Francisco, W. H. Freeman and Company.
19. Jenden, P.D. (1985) *Analysis of Gases in the Earth's Crust*, Final Report to the Gas Research Institute for the period 1 January 1982 - 28 February 1985, Contract No. 5081-360-0533, 110p.
20. Katz, S.A., Khilyuk, L.F., and Chilingarian, G.V., 1994. Interrelationships among subsidence owing to fluid withdrawal, gas migration to the surface and seismic activity. Environmental aspects of oil production in seismically active areas. *J.Pet.Sci.Engr.*, 11:103-112
21. Khilyuk, L.F., Chilingar, G.V., Endres, B.L., and Robertson, J.O., 2000. *Gas Migration - Events Preceding Earthquakes*, Butterworth-Heinemann Publisher, 225 Wildwood Ave., Woburn, Massachusetts, 389 pp.
22. Kilburn, K.H., 1998. *Chemical Brain Injury*, Van Nostrand Reinhold Publisher.
23. Kilburn, K.H., 1999. Evaluating health effects from exposure to hydrogen sulfide: Central nervous system dysfunction. *Environmental Epidemiology and Toxicology* 1: 207-216
24. Marlow, R.S., 1989. Cement bonding characteristics in gas wells, *Journal of Petroleum Technology*, November 1989, 1146-1153.
25. McMillen, S.J., Magaw, R.I., Carovillano, R.I., 2001. *Risk-based Decision-making for Assessing Petroleum Impacts at Exploration and Production Sites*, published by Department of Energy and the Petroleum Environmental Research Forum.
26. Riegle, J.R., 1953. Gas storage in the Playa del Rey oil field. In *Summary of Operations, California Oil Fields*. State of California Division of Oil and Gas, San Francisco, CA, 39(2):17-33.
27. Rixey, W.G., 2001. An evaluation of benzene risk. In: S.J. McMillen, R.J. Magaw, and R.L. Carovillano (Editors), *Risk-Based Decision-Making for Assessing Petroleum Impacts at Exploration and Production Sites*, pp. 156-173. Petroleum environmental Research Forum and the United States Department of Energy.
28. Schoell, M., 1983. Genetic characterization of natural gases., *A.A.P.G. Bul.*, 67:2225-2238.
29. Schoell, M., Jenden, P.D., Beeunas, M.A., and Coleman, D.D., 1993. Isotope analysis of gases in gas field and gas storage operations. *SPE No. 26171, SPE Gas Technol. Symp.*, Calgary, Alberta, Canada June 28-30, pp.337-344.
30. Schumacher, D. and Abrams, M.A. (eds.), 1994. *Hydrocarbon Migration and Its Near-Surface Expression*. AAPG memoir, 66, 350 pp.
31. Tek, M.R., 1987. *Underground Storage of Natural Gas*, Contributions in Petroleum Geology and Engineering, No. 3, G.V. Chilingar (ed.), Gulf Publishing Co., Houston, TX, 389 pp.
32. Tissot, B.P., and Welte, D.H., 1978. *Petroleum Formation and Occurrence*, Berlin: Springer-Verlag.
33. Toth, J., 1996. Thoughts of a hydrogeologist on vertical migration and near-surface geochemical exploration for petroleum. *AAPG Memoir* 66: 279-283.
34. Watters, L.T. and Sabinas, F.L., 1980. *Field Evaluation of Method to Control Gas Flow Following Cementing*, SPE paper 9287 presented at the 1980 SPE Annual Technical Conference, Dallas, Sept. 21-24.

35. Wentworth, C.M., Ziony, J.I., and Buchanan, J.M., 1969. *Preliminary Geologic Environmental Map of the Greater Los Angeles Area, California*.

### Figures

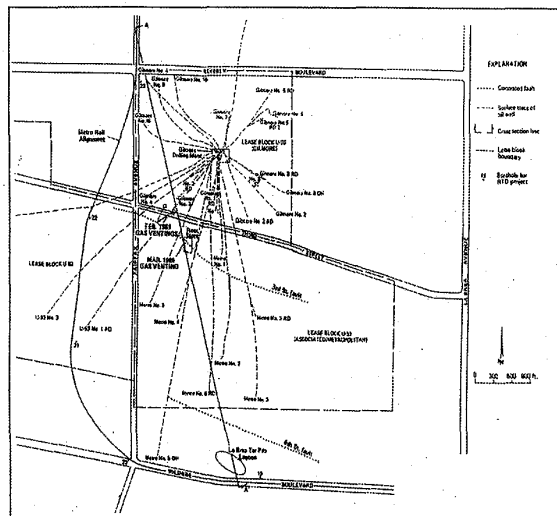

Figure 1. Surface, plan of wells, faults, and gas ventings in the vicinity of Ross Store site (Fairfax and Third St., Los Angeles, California). (Courtesy of Richard Meehan, Palo Alto, California.)

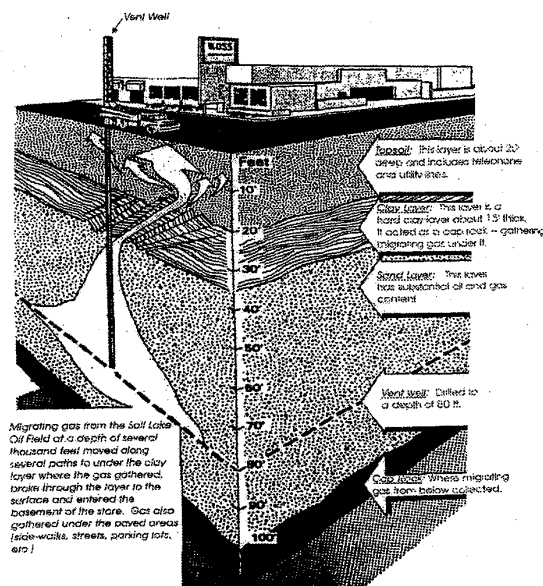

Figure 2. Schematic showing how gas entered the basement of the department store and the surrounding area. (Modified after an article by George Ramos and Ted Thackrey in the Los Angeles Times, 1985; illustration by Michael Hall.)

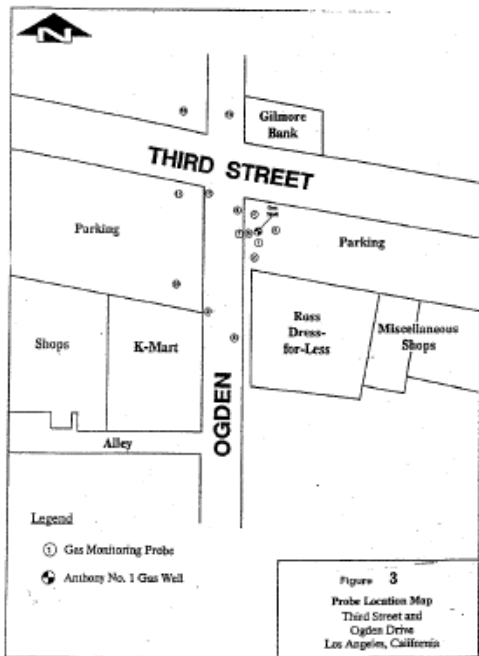

Figure 3. Probe location map; 3<sup>rd</sup> St. and Ogden Drive, Los Angeles, California. (Courtesy of City of Los Angeles Fire Department.)

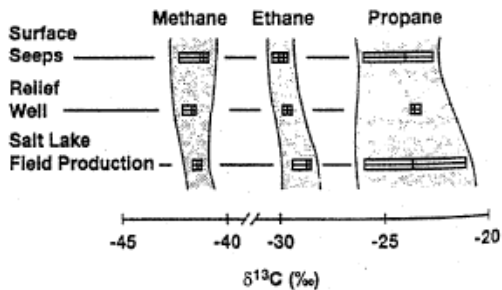

Figure 4. Carbon isotopic fingerprinting of gas leaking from reservoir to the surface. (After Schoell et al., 1993, p. 7, fig. 8.)

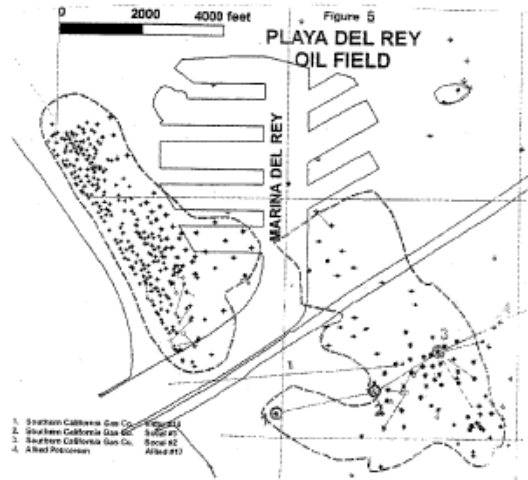

Figure 5. Playa Del Rey Oilfield. (Courtesy of Jack West, Petroleum Geologist, Fullerton, California.)

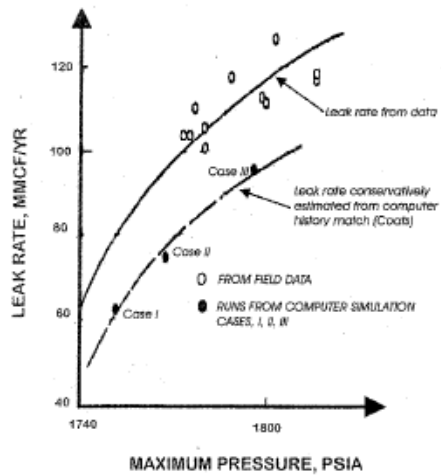

Figure 6. Gas leak rate for various maximum reservoir pressures for Leroy Gas Storage project, Wyoming. (Modified after Tek, 1987, fig. 11-16.)

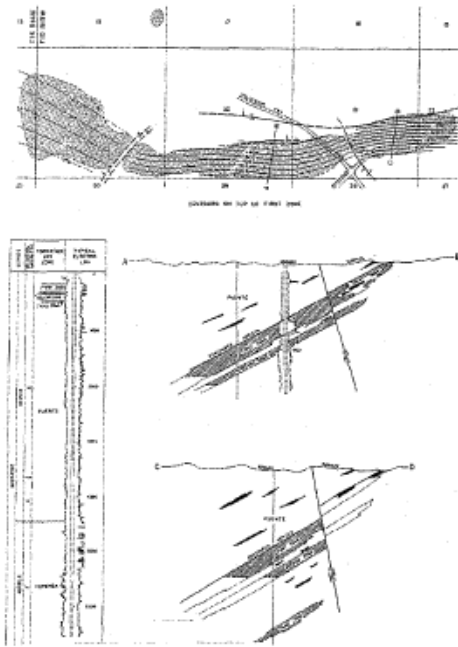

Figure 7. Los Angeles City Oilfield. (After California Division of Oil and Gas.)

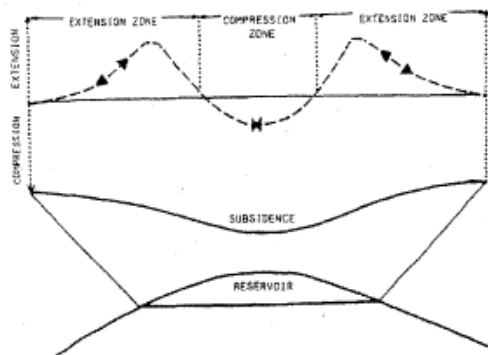

Figure 8. Schematic diagram of compressive and tensile stress distribution in subsiding formations. (Modified after Gurevich and Chilingarian, 1993, fig. 1, p. 244).

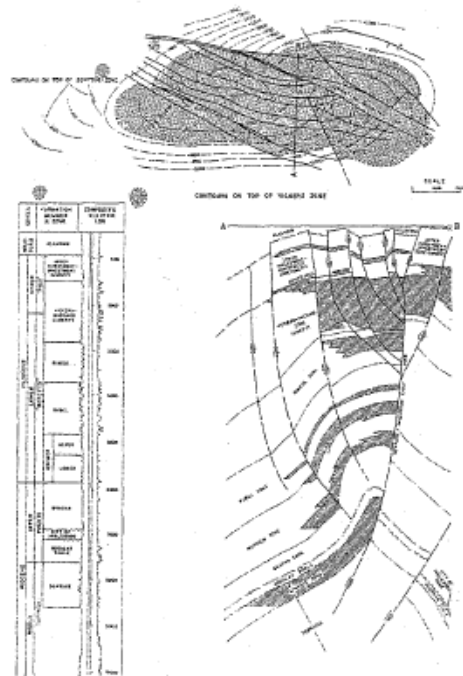

Figure 9. Structural contour map of the Inglewood Oilfield, Los Angeles, California. Contours are on top of the Vickers Zone. (After California Division of Oil and Gas, 1991.)

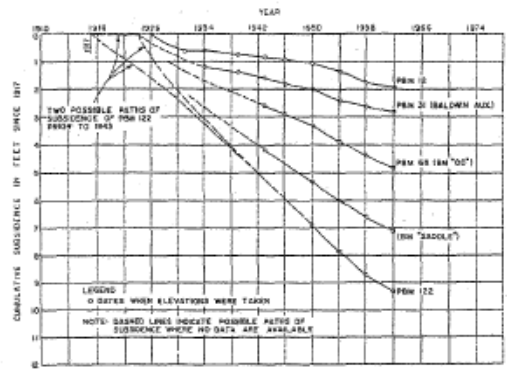

Figure 10. Subsidence of benchmarks, Baldwin Hills Area, Los Angeles, California. (After California Department of Water Resources, Baldwin Hills Reservoir, Apr. 1964).

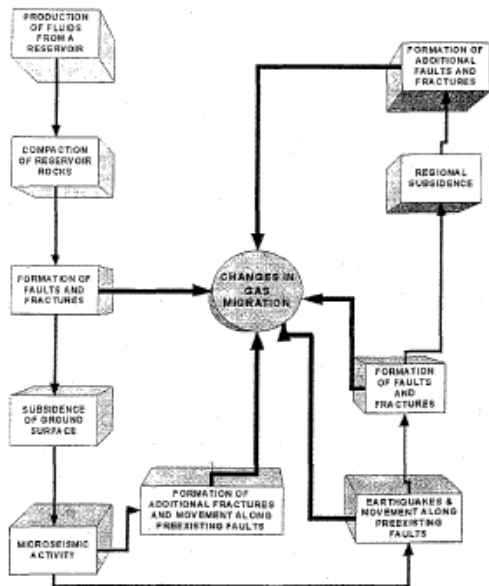

Figure 11. Schematic diagram of system relationships among the production of fluids, compaction, subsidence, and seismic activity. (Modified after Chilingarian et al., 1995, fig. 1, p. 41.)

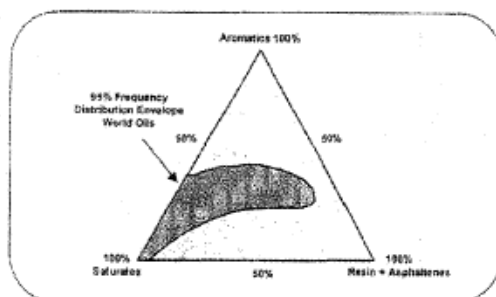

Figure 13. Ternary diagram showing the class composition of crude oils. (After Tissot and Welte, 1978.)

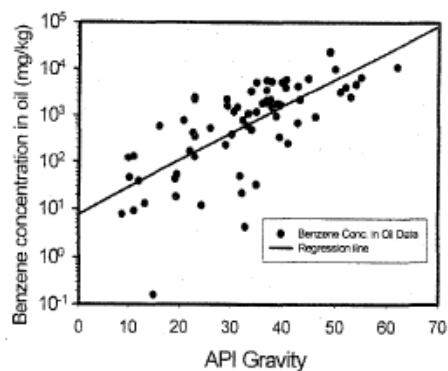

Figure 12. Benzene concentrations versus API gravity for 61 crude oils and 14 condensates (API gravity data were unavailable for 8 crude oils). (After Rixey, 2001.)

**ABANDONMENT/DEMOLITION STUDY**

**Playa del Rey Storage Facility**

**Southern Region Transmission**

**November 22, 1993**

- 5) O&M expenses at playa del rey incurred from 1996 thru 2000 (1994\$) for cushion gas recovery phase:  
 1996 = \$1,500,000  
 1997 = \$1,000,000  
 1998 = \$750,000  
 1999 = \$500,000  
 2000 = \$500,000
- 6) Land Sale (1994\$) = \$16,400,000 (\$13,000,000 for land on bluff sold in 1998 and \$3,400,000 for other land sold in 2001)  
 Adjusting for inflation and net of taxes, total after tax gain = \$10,436,000 (nominal \$).
- 7) Recovery of cushion gas and after tax net gain (nominal\$) using 41% tax rate:

| year | bcf sold | sales price | purchase price | after tax net |
|------|----------|-------------|----------------|---------------|
| 1996 | 1.4      | \$2.23      | \$0.25         | \$1,632,000   |
| 1997 | 1.0      | \$2.29      | \$0.25         | \$1,205,000   |
| 1998 | 0.4      | \$2.36      | \$0.25         | \$498,000     |
| 1999 | 0.3      | \$2.43      | \$0.25         | \$386,000     |
| 2000 | 0.2      | \$2.51      | \$0.25         | \$266,000     |

**costs specific to case 2a - abandon playa del rey and do not replace injection capacity**

- 1) Incremental O&M expenses for injection compressors, starting in 1996 = \$269,000/yr (1994\$).
- 2) Incremental fuel expense for injection compressors, starting in 1996 = \$648,000/yr (1994\$).

**costs specific to case 2b - abandon playa del rey and do replace injection capacity**

- 1) Capital cost of replacing injection capacity at Aliso Canyon of \$30,000,000 (1994\$ excl afudc). Construction period from 1994 - 1995. Inservice in 1996.
- 2) O&M expense for injection compressors, starting in 1996 = \$459,000/yr (1994\$).
- 3) Fuel expense for injection compressors, starting in 1996 = \$950,000/yr (1994\$).

cc: M.P. Sweeney



## Interoffice Memo

To: M.A. Forster  
From: M.D. Middleton *MJM/DKC*  
Date: November 22, 1993  
Subject: Playa del Rey Demolition Estimate

Attached is the Playa del Rey demolition study compiled by Southern Region. This study includes property appraisals and a full assessment of costs associated with decommissioning and abandoning the compressor station, tank farm, and well sites. Also included is a summary of public affairs and political issues involving Playa del Rey.

If you require further information, please contact David Carroll at 578-2623.

DHC/mck  
Attachment

cc: D.H. Carroll  
Claus Langer

## Phase I — Compressor Station Abandonment

Phase I would include decommissioning, abandonment, and removal of all existing compression and injection process equipment. This equipment is located on top of the bluff. Isolation and modification of piping systems would be performed in a manner to allow continued withdrawal operations.

The demolition of all buildings including the general headquarters offices, garage, maintenance buildings, and other surface structures would also be a part of Phase I. The baseball facility would also be razed at this time.

Well abandonments would begin during the first year of Phase I. It is anticipated that approximately 13 wells and wellsites would be completed the first year. Well abandonments would continue in following years with only those wells required for reservoir monitoring and recovery of cushion gas remaining. Completion of all well and wellsite abandonments is expected to require 4 years.

The tank farm would remain in limited service condition to process gas and fluids withdrawn from the reservoir for an estimated four years. Operating and maintenance expenses related to tank farm and withdrawal operations would continue to be incurred during Phase I.

marketing of the property on top of the bluff could begin in the second year of the project.

The cost of Phase I is estimated at \$6,399,921 and would be complete at the end of the first year.



## Phase II — Storage Field Depletion and Gas Recovery

Phase II involves the continuation of well and wellsite abandonments, storage field gas recovery, and operation of the tank farm.

After the initial withdrawal of gas into Line 1167, the field will be drawn down to Line 1159 pressure of 150 psi. Further recovery may be achieved by flowing into the local Distribution system at approximately 50 psi. Low flow rates near 500 mcf/day are anticipated and will most likely require compression during the third year to increase gas recovery rates. A skid mounted low pressure compressor package could be leased and installed in the tank farm area. Sound mitigation from this compressor will be a challenge and will require a temporary enclosure.

During Phase II additional wellsite properties will become available for marketing.

Drawdown of the reservoir (gas recovery) has been estimated to require four years.

It is anticipated that 38 wells will be abandoned during Phase II. Five wells will remain for five additional years to monitor field activity and capture minor volume of gas recovered.

The cost of Phase II has been estimated at \$8,336,000.

### Phase III — Tank Farm Abandonment and Final Clean-up

Phase III involves the demolition and site remediation of the tank farm and lower bluff areas. Phase III would commence after all gas recovery and reservoir management work has been completed. (Demolition of the tank farm will occur during the fourth year.

A significant amount of excavating and backfill work will be required due to the many field lines buried in the tank farm and lower bluff areas.

Environmental remediation may require significant disposal of contaminated soil and the importation of clean fill. There is also a potential for the discovery of ground water contamination. This environmentally sensitive area will no doubt provide significant challenges related to keeping our costs within forecasts. There is a potential for very high clean-up costs beyond current estimates because the Ballona Wetlands are immediately adjacent to our facilities.

The Gas Company may be required by regulatory agencies (the DOG, for example) to continue some type of monitoring activities. This may require that some monitoring wells remain indefinitely and that leakage surveys be conducted.

For the purpose of forecasting costs related to completion of the field decommissioning, it is assumed that all wells will be abandoned.

The tank farm is located on lease property which will not be marketable.

Phase III will require 1 year to complete at an estimated cost of \$2,633,589.

## Conclusion

The high cost of operating and maintaining the Playa del Rey Storage Field compared against throughput, station load factor, and historical utilization strategy dictates that the continued operation of this facility be assessed based on a value added to our business.

The overall cost to decommission and abandon the Playa del Rey Storage Field has been estimated at \$17,369,510. The time necessary to complete the work required is four years.

Gas transmission system enhancements and modifications are necessary to offset the loss of Playa del Rey. These improvements would need to be operational before Playa del Rey could be abandoned. (See Appendix 2.)

The revenue generated from the sale of properties will offset the cost of abandoning Playa del Rey. However, substantial capital investment (23.3 million) will be required elsewhere in the Transmission and Storage System to offset the loss of Playa del Rey. (See Appendix 2.) It is anticipated that these system improvements will be activated with or without the loss of Playa del Rey withdrawal.

It should also be noted that the real estate market is currently very depressed in Playa del Rey and that property values have dropped significantly over the last three years. Existing surplus properties are not selling. Therefore Southern Region recommends that Maguire Thomas Partners be approached regarding their possible interest in acquiring the site. The value of owning additional properties by MTP in the area may be attractive due to the Playa Vista development.

Operating and maintenance costs will be reduced substantially during the first year of the project due to the decommissioning of the compressor facilities.

## Assumptions

The following assumptions should be considered when evaluating the feasibility, risk and costs related to the Playa del Rey abandonment:

- There is high potential that environmental costs associated with demolishing and cleanup of the PDR tank farm and related areas could escalate due to adjacent ground water contamination.
- Local Gas Company image may decay if PDR property were sold to Playa Vista developers. Media and environmental group attention is anticipated.
- The need for compliance with air quality regulations would be eliminated (\$18,000,000 cost avoidance). These capital dollars could be applied toward system upgrade and improvements.
- System upgrades and improvements identified in System Engineering's report (Appendix 2) will most likely occur whether PDR storage is eliminated or not.
- Annual O&M costs associated with Playa del Rey would be eliminated. (Region O&M \$3,694,800, Storage Operations O&M \$500,000, fuel cost \$230,800).

## Cost Estimates

### CONTRACT ABANDONMENT AND DEMOLITION COSTS

|                                                                      | <b>Non-Labor</b>    |
|----------------------------------------------------------------------|---------------------|
| 56 Well Abandonments (sub-surface)                                   | 5,152,000           |
| 56 Wellsite Abandonments (surface)                                   | 4,200,000           |
| Wellsite Environmental Cleanup                                       | 2,240,000 ✓         |
| Compressor Demolition (office, warehouse, etc.)                      | 1,917,650           |
| Tank Farm Demolition                                                 | 668,714             |
| Little League Field Demolition                                       | 21,146              |
| Environmental Investigation & Remediation (tank farm and plant site) | 2,000,000 ✓         |
|                                                                      | <u>\$16,199,510</u> |

### COSTS ASSOCIATED WITH ABANDONMENT/DEMOLITION

#### Preparation and Inspection

|                                                     | Labor         | Non-Labor    | Total              |
|-----------------------------------------------------|---------------|--------------|--------------------|
| Purging (piping, tanks, vessels, etc.)              | 25,000        | 30,000       | 55,000             |
| Liquid Clean-out (piping, tanks, vessels, etc.)     | 10,000        | 150,000      | 160,000            |
| Piping modifications, abandonments, and relocations | 75,000        | 400,000      | 475,000            |
| Inspection Costs (4-year term)                      | 295,000       |              | 295,000            |
| Permit Fees                                         |               | 5,000        | 5,000              |
| Planning                                            | 75,000        | 25,000       | 100,000            |
| Purchase Misc. Materials                            |               | 50,000       | 50,000             |
| Engineering Haz. Mat. Costs                         | <u>25,000</u> | <u>5,000</u> | <u>30,000</u>      |
|                                                     | 505,000       | 665,000      | <u>\$1,170,000</u> |

**TOTAL ABANDONMENT/DEMOLITION COSTS**     **\$17,369,510**

### PROPERTY VALUES

|                                                                                         |                     |                            |
|-----------------------------------------------------------------------------------------|---------------------|----------------------------|
| Station Property (see Appendix 6)                                                       | 10,000 - 13,000,000 |                            |
| Wellsite Parcels (see Appendix 7)                                                       |                     | <u>15,600,000</u>          |
|                                                                                         |                     | 28,600,000                 |
| Wellsite Parcels (cleared and available for sale prior to this report — see Appendix 7) |                     | (12,245,000)               |
|                                                                                         | <b>Total</b>        | <b><u>\$16,355,000</u></b> |

### ANNUAL OPERATING COSTS

|                    |              |                           |
|--------------------|--------------|---------------------------|
| Southern Region    |              | 3,460,000                 |
| Storage Operations |              | <u>500,000</u>            |
| Fuel Costs         |              | 230,800                   |
|                    | <b>Total</b> | <b><u>\$4,190,800</u></b> |

Brewer, Leigh S.  
Wednesday, April 20, 2005 12:53 PM  
Mansdorfer, Jim  
Thompson, John A.; Peterson, John E.  
University City Syndicate Inc., Ltd.

Creedings, Bill

Yesterday, I got copies of the abandonment work and well log from the DOG for the well, University City. This is one of the wells that Playa Vista re-abandoned for a total of \$2.4 MM. This one is that problem well on the southwest corner of Lincoln and Jefferson. Will send you copies of the records and my latest working papers.

Saturday, During the 2001 re-abandonment, they took a kick from 1850'. The records are sketchy regarding the 5" drill pipe 540' - 5850' fish left in May 1934. Only shavings and small pieces were recovered. Maybe you know more about this and can fill me in. At the end of the work, there were gas bubbles at the surface between the existing 14" and the 10" that they ran, so they dumped 2-sx G-cmt and called it good. Would have liked a sample of that gas and the kick at 1850' too! No wonder Rich Baker was unhappy.

Byway, he is sending me records for the other two wells including their logs. C U tomorrow!

Leigh Brewer  
Senior Engineer  
2-806-4358  
Geocoring Analysis Center



18581 Teller Avenue, Suite 200  
Irvine, California 92612  
tel: 949 752-5452  
fax: 949 752-1307

April 25, 2005

Mr. David Nelson  
Vice President  
Playa Capital Company, LLC  
5510 Lincoln Blvd Suite 100  
Playa Vista, California 90094

Subject: Report of Sampling Results for Gas Bubbles Observed in the  
Freshwater Marsh

Dear Mr. Nelson:

Camp Dresser & McKee Inc. (CDM) has prepared this report to describe its assessment of the gas bubbles observed in the Freshwater Marsh, which is located to the west of the Playa Vista project, near the intersection of Lincoln Boulevard and Jefferson Boulevard. In particular, the purpose of this assessment is to compare the chemical composition of observed gas bubbles with gas from the Southern California Gas Company (Gas Company) Playa Del Rey Storage Field (the "reservoir"), which is located further west of the Freshwater Marsh. Additionally, survey data were reviewed to verify the location of the gas bubbles relative to the University Syndicate Well 1, an exploratory well that was re-abandoned in 2001 to current Division of Oil, Gas, and Geothermal Resources (DOGGR) standards.

#### Overview

During the course of the past 12 years, investigations have specifically explored the issue of whether gas bubbles migrating to the surface have the same composition as gas stored in the reservoir. Each investigation reached the same conclusion: the gases are of different composition and do not originate from the Gas Company reservoir. Additionally, recent surveying indicates the gas bubbles observed in the Freshwater Marsh are more than 200 feet distant from the location of abandoned University Syndicate Well 1. No gas bubbles have been observed in the area proximate to the abandoned well. A detailed discussion of these findings follows.

#### Historical Studies

In 1993, Dr. Ian Kaplan, a Ph.D. in Biogeochemistry from USC and Emeritus Professor of Geology and Geochemistry at UCLA, conducted a study that analyzed and compared gas samples from the Ballona Channel and Centinela Channel and from the Gas Company reservoir. The results of the study were presented in the report titled *Comparison of Chemical*



Mr. David Nelson  
April 25, 2005  
Page 2 of 5

*Properties of Gases Collected in Bubbles Emerging from Centinela and Ballona Creeks*, dated January 20, 1994. The study, which included the participation of Grassroots Coalition and the Gas Company, concluded that the gas observed bubbling in the Centinela and Ballona channels was not emanating from the reservoir.

More recently, in July 2000, CDM completed sampling and analysis of nine of the Gas Company wells within the Playa Del Rey Storage Field. The results of the sampling were presented in the report titled *Sampling and Analysis of Gas from the Southern California Gas Company Playa Del Rey Storage Field* dated September 5, 2000. The gas composition was compared to soil gas samples collected on site to evaluate if the storage field was the source of gas observed at Playa Vista. The result of the comparison was presented by Dr. Ian Kaplan in the report titled *Comparison of Gas Analyses from Southern California Gas Company Injection and Observation Wells with Soil Gas and Groundwater Gas from 50ft Gravel Aquifer* dated January 29, 2001. The data showed no evidence that gas from the reservoir have migrated into the surface soil at the Playa Vista site. The City of Los Angeles Chief Legislative Analyst (CLA), as part of a broader review of methane issues in this area, in consultation with the City of Los Angeles Bureau of Engineering and Department of Building and Safety and with DOGGR concluded "the Southern California Gas Company Playa Del Rey Gas Storage facility is not the source of methane contamination found at the site." (*City Investigation of Potential Issues of Concern for Community Facilities District No. 4 Playa Vista Development Project*, CLA, dated May 2001).

#### March 2005 Evaluation

##### *Sampling of Bubbles from Freshwater Marsh*

Similar to the bubbles observed in the Centinela and Ballona channels, gas bubbles have been observed at the water surface in the Freshwater Marsh at two locations near the intersection of Lincoln and Jefferson Boulevards (Figure 1). On March 17, 2005, CDM accessed the Freshwater Marsh under the supervision of the Freshwater Marsh manager and attempted to collect bubble samples from each location.

At Bubble No. 1, CDM successfully collected the gas emitted from the bubbles by inverting laboratory-supplied sample bottles completely filled with water over the bubbles. At least a portion of the bottle was underwater at all times. In addition, a plastic funnel was submerged and placed at the opening of the inverted sample bottle to direct the bubbles into the container. The gas from the bubbles then filled the bottle while displacing the water. Once filled, the sample bottle was capped underwater preventing the introduction of atmospheric air. CDM was unable to collect a sample at the southernmost bubble location (Bubble No. 2





Mr. David Nelson  
April 25, 2005  
Page 3 of 5

on Figure 1) because the bubble flow rate was too intermittent and sporadic to fill the required sample container(s).

A total of seven 1-liter bottles were collected at Bubble No. 1. During sample collection, CDM recorded the approximate flow rate of the gas bubbles into sample bottles. The gas bubbles filled the sample bottles at a rate of approximately 1 liter per minute.

#### *Sampling of Gas Company Wells*

Samples were also collected from Gas Company observation wells Vidor 14 and Vidor 17 (Figure 2). These wells were selected as the closest to the occurrence of bubbles in the Freshwater Marsh. The gas samples were taken from the well using a sampling manifold with a pressure gauge (supplied by a Gas Company representative) attached to the well tree. Each sample was collected into two laboratory-supplied 300-cubic centimeter (cc) gas cylinders and two 1-liter Tedlar bags. These samples were also collected in duplicate as a precaution. During sample collection, the pressure readings in Vidor-14 and Vidor-17 were 152 psig and 1,323 psig, respectively. A representative from the Gas Company accompanied CDM during the sampling procedures. The Gas Company representative also collected two Tedlar bag samples for separate laboratory analysis.

#### *Sample Analysis*

The seven 1-liter bottles, four gas cylinders, and four Tedlar bags, which included an initial sample and precautionary backup samples, were submitted to two laboratories for off-site analysis. A total of four bottles and two Tedlar bags were submitted to Columbia Analytical Services of Simi Valley, California (Columbia) for benzene, toluene, ethyl benzene, total xylenes (BTEX) and hydrogen sulfide (H<sub>2</sub>S) analysis. Three bottles and the gas cylinders were submitted to Isotech Laboratories, Inc. of Champaign, Illinois (Isotech) for molecular and isotopic composition analysis including carbon monoxide, helium, hydrogen, argon, oxygen, nitrogen, carbon dioxide, light hydrocarbons (including methane, ethane, ethane, pentane, propane, iso-butane and n-butane), the Delta 13C of carbon dioxide, methane and ethane and the Delta D of methane. The results of analyses are provided on the laboratory reports attached to this report.

#### *Discussion of the Results*

The results of the molecular and isotopic composition analysis are summarized in Table 1. The results for BTEX and H<sub>2</sub>S are summarized in Table 2. Data from the Gas Company wells were compared against prior data sets. The sample results (gas composition and isotopic fingerprint) from Vidor 14 and 17 are similar to the data collected from other reservoir



Mr. David Nelson  
April 25, 2005  
Page 4 of 5

monitoring wells in 2000 suggesting the composition of the gas storage reservoir has remained generally consistent.

Most natural gas accumulations in Southern California contain only trace amounts of helium (i.e., less than 0.001 mol %), whereas the gas imported into the storage reservoir typically contains helium on the order of 0.01 to 0.04 mol %. The two storage facility samples contained helium at concentrations of 0.0234 and 0.0058 mol %. Helium concentrations in the Freshwater Marsh bubble sample were below reporting limits (awaiting reporting limits from the lab), which would suggest that the bubbles represent a local natural source of gas rather than leakage from the reservoir.

The methane isotopic characterization data from the samples is plotted on Figure 3. The data indicate that the Freshwater Marsh bubble sample is distinctly different from the two samples collected from the storage reservoir. Specifically, the signature of the Freshwater Marsh bubble sample suggests a different mechanism of formation (i.e. microbial (biogenic) gas formed by CO<sub>2</sub> reduction) as compared to the two gas storage reservoir samples (i.e., thermogenic gas). The findings are consistent with those previously observed during the 2000 and 2001 studies.

Columbia Analytical indicated that the two storage reservoir samples had significant concentrations of mercaptans and other sulfur-containing markers, whereas the Freshwater Marsh bubble sample did not. Mercaptans are the odorous compounds that gas companies amend natural gas with prior to delivery to the consumers.

In summary, isotopic analysis of gas samples collected in the Freshwater Marsh and from Gas Company observation wells demonstrate the samples are of different composition and that the bubbles observed in the Freshwater Marsh do not originate from the Gas Company reservoir. This finding is consistent with the conclusion reached in the Kaplan 2001 study.

## Survey Evaluation

### *Field Surveying*

On April 22, 2005 Psomas, a California licensed surveyor, accessed the Freshwater Marsh under the supervision of the Freshwater Marsh manager, for the purpose of accurately establishing the location of the observed gas bubbles. The survey data collected by Psomas was converted to northing and easting coordinates, and then compared to the coordinates for the abandoned University Syndicate Well 1 that are on file with DOGGR. As depicted on Figure 4, the gas bubbles lie approximately 228.8 feet westerly/southwesterly of the abandoned University Syndicate Well 1.



Mr. David Nelson  
April 25, 2005  
Page 5 of 5

Please do not hesitate to contact Michele Zych at (949) 752-5452 should you have any questions or require further information.

Very truly yours,

A handwritten signature in black ink, appearing to read 'Michele Zych', with a long horizontal flourish extending to the right.

Michele Zych  
Senior Project Manager  
Camp Dresser & McKee Inc.

Attachments

Figure 1  
Locations of Bubbles in Freshwater Marsh  
Playa Vista

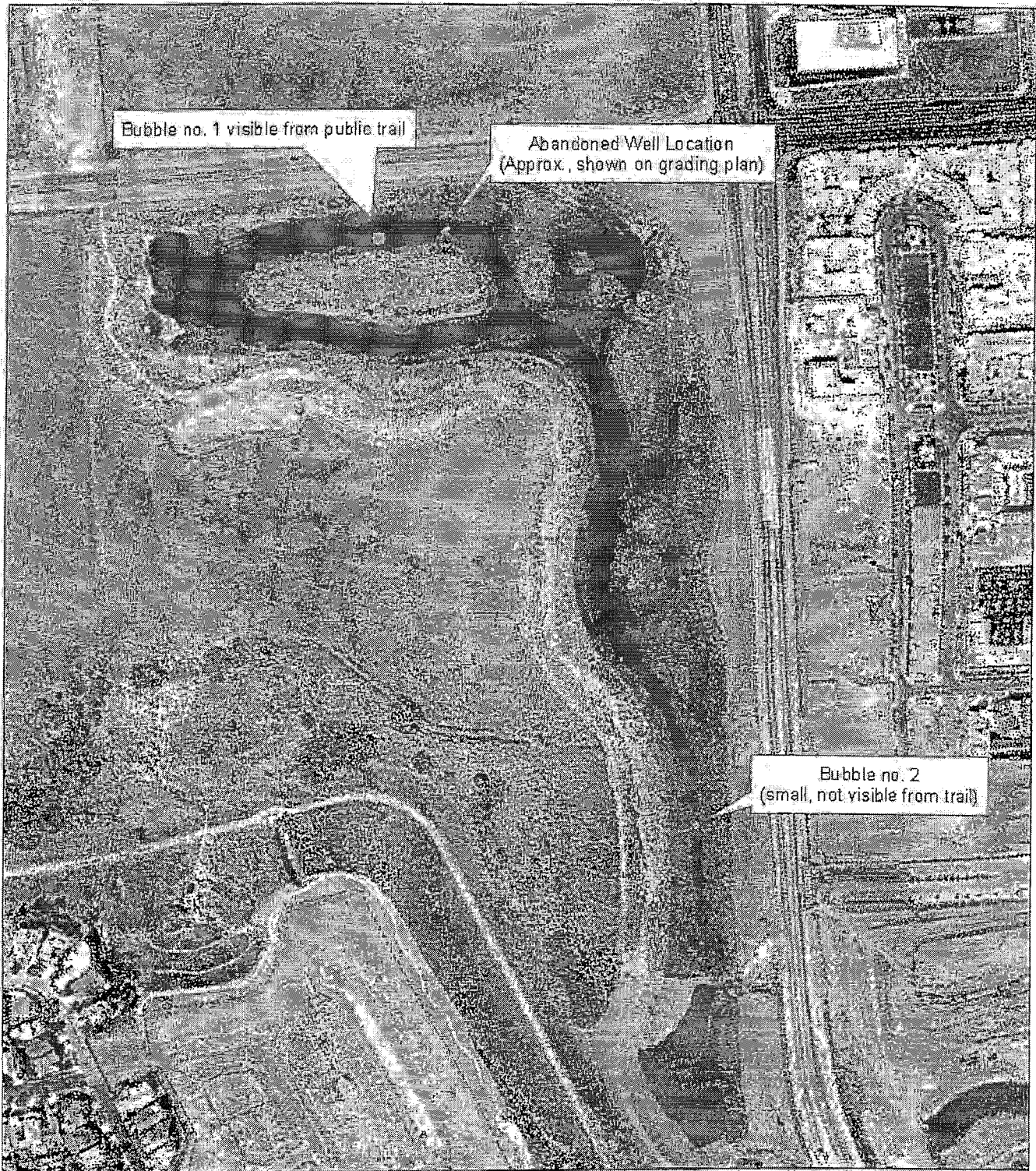

Aerial September 2004

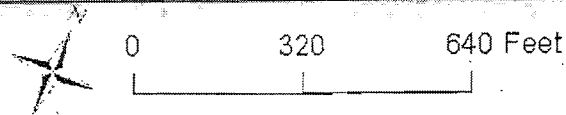

Figure 2  
Well Location Map

TAKEN FROM  
STATE OF CALIFORNIA  
DEPARTMENT OF CONSERVATION  
DIVISION OF OIL, GAS,  
AND GEOTHERMAL RESOURCES

SCALE IN FEET  
0 400 800 1200 1600

FEBRUARY 6, 1959

LEGEND

- |       |                                |    |                           |
|-------|--------------------------------|----|---------------------------|
| ----- | PLAYA VISTA PROPERTY BOUNDARY  | ⊙  | WELLS SAMPLED             |
| ○     | DRILLING                       | ○B | OBSERVATION WELL          |
| ○D    | DRILLING-IDLE                  | ○W | INJECTION/WITHDRAW WELL   |
| ○B    | BURIED-IDLE                    | ⊙* | IDLE-GAS                  |
| ○P    | PLUGGED AND ABANDONED-DRY HOLE | ⊙* | BURIED-IDLE GAS           |
| ○C    | COMPLETED-OIL                  | ⊙* | PLUGGED AND ABANDONED-GAS |
| ○O    | IDLE-OIL                       | ⊙* | COMPLETED WATER SOURCE    |
| ○D    | BURIED IDLE-OIL                | ⊙* | COMPLETED WATER DISPOSAL  |
| ○P    | PLUGGED AND ABANDONED-OIL      | ⊙* | COMPLETED WATERFLOOD      |
| ○O    | OBSERVATION                    | ⊙* | COMPLETED STEAMFLOOD      |
| ----- | FIELD BOUNDARY                 | ⊙* | COMPLETED GAS STORAGE     |

NOTE: WELLS WITH DIRECTIONAL SURVEYS ON FILE WITH THE DIVISION OF OIL AND GAS ARE INDICATED WITH A SHORT LINE UNDER THE WELL SYMBOL.  
CURRENT WELL STATUS SHOULD BE CONFIRMED AT THE APPROPRIATE DIVISION OF OIL AND GAS DISTRICT OFFICE.

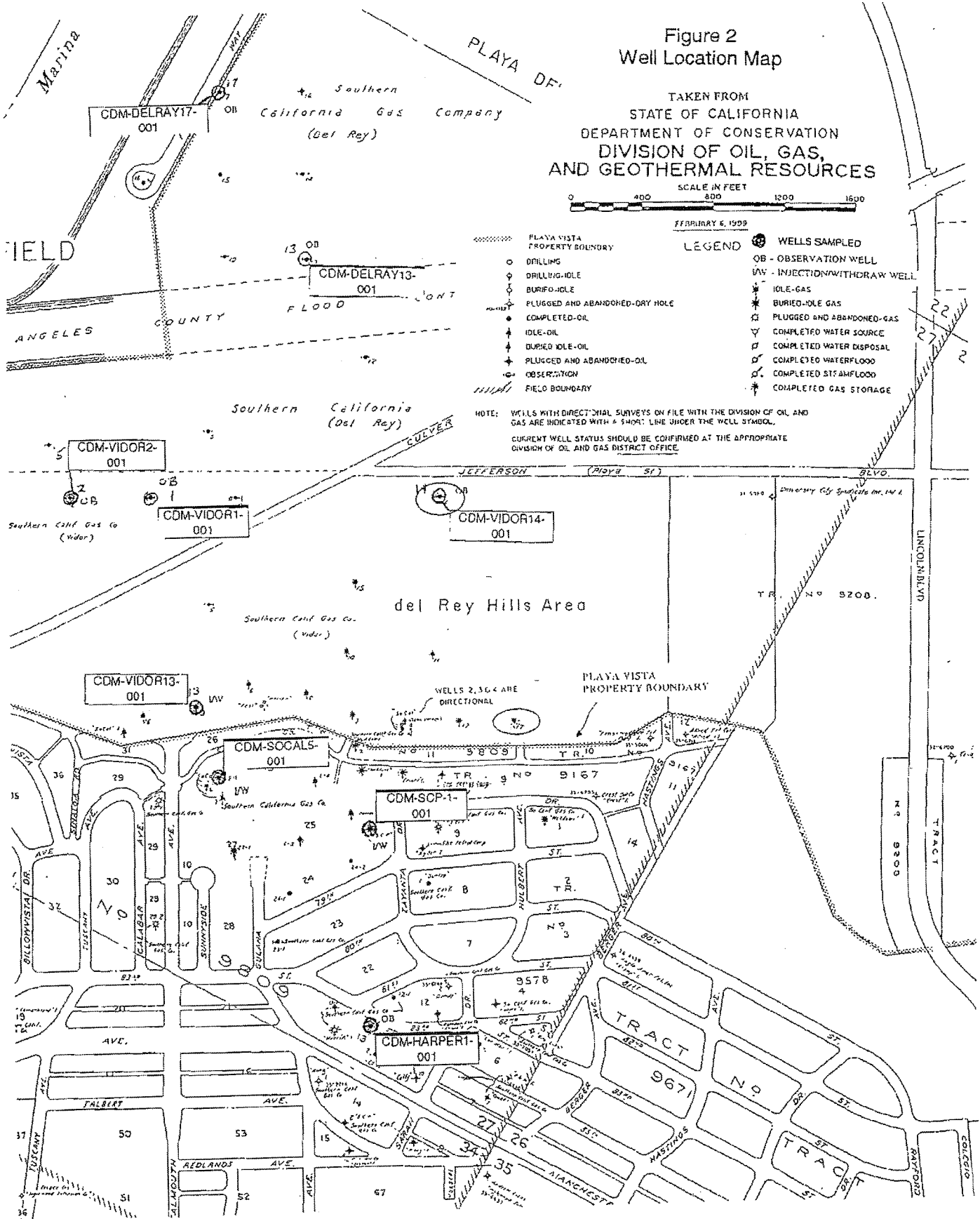

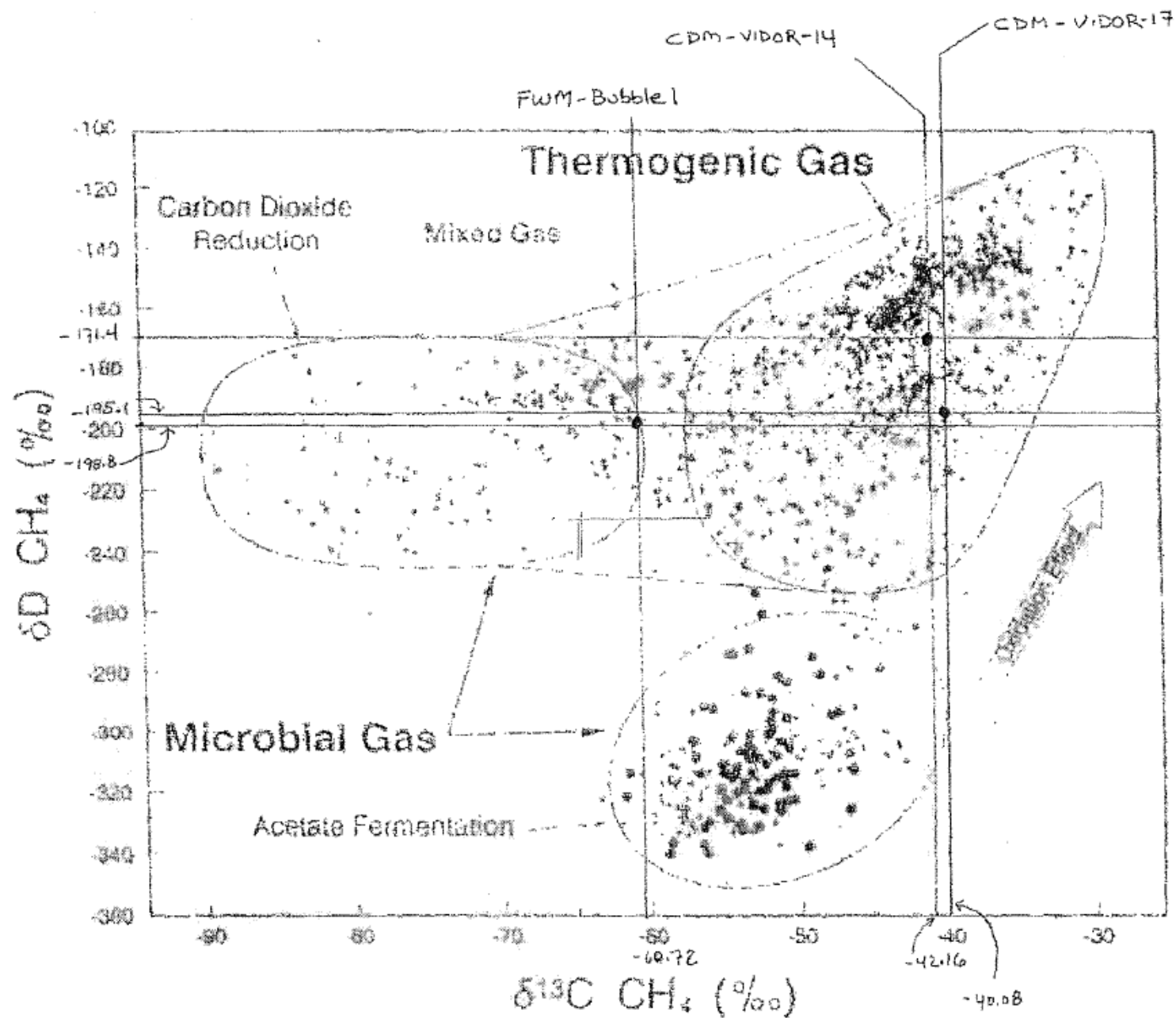
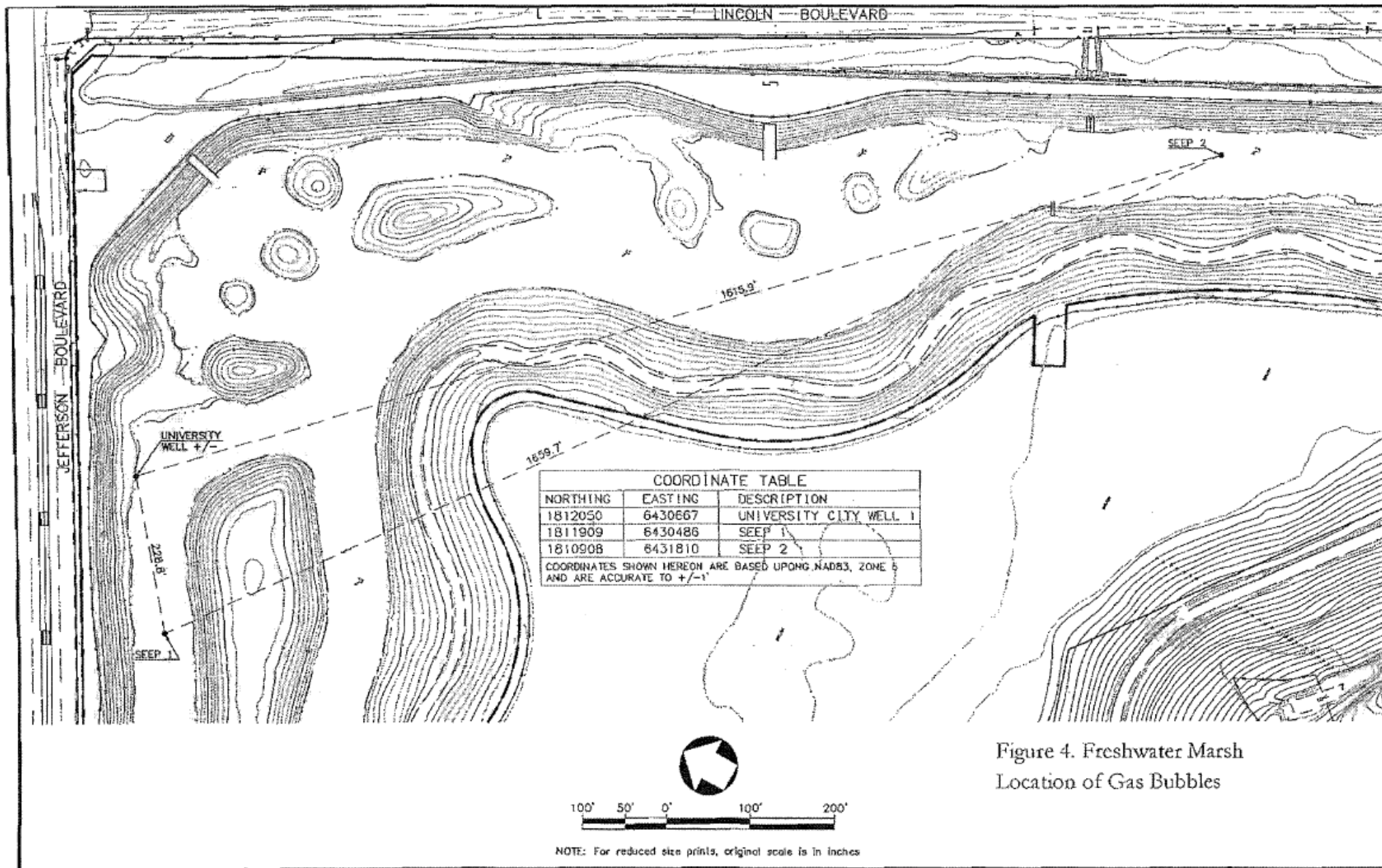

Figure 3- Comparison of isotopic data from samples from Freshwater Marsh and the SoCal Gas Wells



**COORDINATE TABLE**

| NORTHING | EASTING | DESCRIPTION            |
|----------|---------|------------------------|
| 1812050  | 6430667 | UNIVERSITY CITY WELL 1 |
| 1811909  | 6430486 | SEEP 1                 |
| 1810908  | 6431810 | SEEP 2                 |

COORDINATES SHOWN HEREON ARE BASED UPON NAD83, ZONE 6 AND ARE ACCURATE TO +/- 1'

Figure 4. Freshwater Marsh  
Location of Gas Bubbles

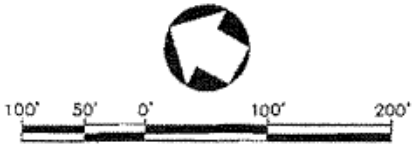

NOTE: For reduced size prints, original scale is in inches

Plotted: 01/22/08 10:30:13 W:\Projects\AREAS-IP\ARC/INFO\PL\PV1612-01.DWG

Table 1  
 Summary of Analytical Results  
 Compositional Analysis - Samples from Freshwater Marsh and SoCal Gas Wells  
 Playa Vista

| Sample Names                |         | Freshwater Marsh | Injection/Withdrawal Wells |                |                 | Observation Wells |                 |               |               |                  |                  |                | Metering Station |               |
|-----------------------------|---------|------------------|----------------------------|----------------|-----------------|-------------------|-----------------|---------------|---------------|------------------|------------------|----------------|------------------|---------------|
|                             |         | FWM-Bubble 1     | CDM-SCP-1-001              | CDM-SOCALS-001 | CDM-VIDOR13-001 | CDM-VIDOR2-001    | CDM-VIDOR14-001 | CDM-VIDOR-14  | CDM-VIDOR-17  | CDM-DELRAY13-001 | CDM-DELRAY17-001 | CDM-VIDOR1-001 | CDM-HARPER1-001  | CDM-METER-001 |
| Sample Date                 |         | 3/21/2005        | 07/27/2000                 | 07/27/2000     | 07/27/2000      | 07/27/2000        | 07/27/2000      | 3/22/2005     | 3/22/2005     | 07/27/2000       | 07/27/2000       | 07/27/2000     | 07/27/2000       | 07/27/2000    |
| Carbon Monoxide             | mol %   | <0.01            | --                         | --             | --              | --                | --              | <0.01         | <0.01         | --               | --               | --             | --               | --            |
| Hydrogen Sulfide            | mol %   | (see Table 2)    | --                         | --             | --              | --                | --              | (see Table 2) | (see Table 2) | --               | --               | --             | --               | --            |
| Helium                      | mol %   | <0.0010          | 0.0120                     | 0.0110         | 0.0120          | 0.0013            | 0.0340          | 0.0234        | 0.0058        | 0.0022           | 0.0120           | 0.0082         | 0.0094           | 0.0110        |
| Hydrogen                    | mol %   | <0.0010          | --                         | --             | --              | 0.0020            | 0.0085          | 0.0148        | <0.0010       | 0.071            | --               | 0.0081         | --               | 0.0015        |
| Argon                       | mol %   | 0.0871           | 0.0066                     | 0.0026         | 0.0053          | --                | 0.0049          | 0.0183        | 0.0056        | --               | --               | --             | 0.011            | 0.0037        |
| Oxygen                      | mol %   | 0.602            | --                         | --             | --              | --                | --              | 0.169         | <0.004        | --               | --               | --             | --               | --            |
| Carbon Dioxide              | mol %   | 0.63             | 1.25                       | 1.31           | 1.15            | 15.03             | 0.58            | 0.54          | 0.98          | --               | 3.70             | 12.75          | 7.57             | 1.17          |
| Nitrogen                    | mol %   | 3.01             | 0.65                       | 0.56           | 0.69            | 0.17              | 1.26            | 2.36          | 0.42          | 28.13            | 0.43             | 0.40           | 1.17             | 0.55          |
| Methane                     | mol %   | 95.55            | 95.62                      | 96.03          | 95.39           | 75.40             | 91.62           | 90.56         | 95.22         | 57.53            | 69.21            | 78.14          | 81.66            | 96.35         |
| Ethane                      | mol %   | 0.24             | 1.87                       | 1.61           | 2.10            | 4.50              | 4.74            | 4.67          | 2.51          | 6.35             | 4.17             | 4.04           | 4.83             | 1.68          |
| Ethylene                    | mol %   | <0.002           | --                         | --             | --              | --                | --              | <0.002        | <0.002        | --               | --               | --             | --               | --            |
| Propane                     | mol %   | <0.0010          | 0.34                       | 0.31           | 0.43            | 2.63              | 1.12            | 1.17          | 0.56          | 4.28             | 1.67             | 2.39           | 2.54             | 0.23          |
| Iso-butane                  | mol %   | <0.0010          | 0.047                      | 0.042          | 0.055           | 0.35              | 0.10            | 0.104         | 0.0843        | 0.65             | 0.16             | 0.38           | 0.35             | 0.031         |
| n-Butane                    | mol %   | <0.0010          | 0.067                      | 0.058          | 0.075           | 0.82              | 0.17            | 0.163         | 0.092         | 1.57             | 0.31             | 0.90           | 0.76             | 0.034         |
| iso-pentane                 | mol %   | <0.0010          | 0.02                       | 0.016          | 0.02            | 0.33              | 0.053           | 0.0405        | 0.0269        | 0.49             | 0.058            | 0.31           | 0.24             | 0.01          |
| n-Pentane                   | mol %   | <0.0010          | 0.019                      | 0.014          | 0.015           | 0.31              | 0.059           | 0.0373        | 0.0207        | 0.44             | 0.05             | 0.27           | 0.21             | 0.0085        |
| Hexanes+                    | mol %   | <0.0010          | 0.095                      | 0.037          | 0.057           | 0.46              | 0.25            | 0.127         | 0.0776        | 0.49             | 0.23             | 0.40           | 0.45             | 0.026         |
| Delta 13C in Carbon Dioxide | per mil | -23.05           | 11.26                      | 12.70          | 11.17           | -10.69            | -2.99           | -0.83         | 6.43          | n/a              | -2.31            | -11.32         | -3.47            | 13.26         |
| Delta 13C in Methane        | per mil | -80.72           | -42.18                     | -42.69         | -42.31          | -40.51            | -42.37          | -42.16        | -40.06        | -41.97           | -41.25           | -41.90         | -44.66           | -42.15        |
| Delta Oxygen in Methane     | per mil | -198.8           | -202.4                     | -202.3         | -202.2          | -183.7            | -174.2          | -171.4        | -195.1        | -190.9           | -184.0           | -186.3         | -197.1           | -204.7        |
| Delta C13 in Ethane         | per mil | -19.83           | -28.57                     | -29.20         | -28.43          | -29.42            | -32.66          | -32.78        | -27.55        | -29.40           | -29.71           | -29.99         | -30.60           | -27.85        |

Note:  
 < = Not detected above laboratory reporting limits shown  
 -- = Not detected (laboratory reporting limits not provided)  
 n/a - not available



Table 2  
 Summary of Analytical Results  
 Volatile Organic Compounds and Hydrogen Sulfide - Samples from Freshwater Marsh and SoCal Gas Wells  
 Playa Vista

|                  |      | Freshwater Marsh | SoCal Gas Observation Wells |              |
|------------------|------|------------------|-----------------------------|--------------|
| Sample Names     |      | FWM-Bubble 1     | CDM-Vidor-14                | CDM-Vidor-17 |
| Sample Date      |      | 3/21/2005        | 3/22/2005                   | 3/22/2005    |
| Benzene          | ppbV | ND<0.78          | 68,000                      | 18,000       |
| Toluene          | ppbV | 0.92             | 74,000                      | 16,000       |
| Ethylbenzene     | ppbV | 1.2              | 2,700                       | 1,500        |
| m,p-Xylenes      | ppbV | 3.2              | 3,700                       | 5,800        |
| o-Xylene         | ppbV | 1.5              | 1,100                       | 1,600        |
| Hydrogen Sulfide | ppbV | 8.34             | ND<5.0                      | 3.34 J       |

Note:  
 ND - Not detected above laboratory reporting limits  
 J - estimated concentration below laboratory reporting limits but above method detection limits.  
 ppbV - part per billion vapor

Table 3  
 Summary of Data in Comparison to Risk-Based Concentrations  
 Samples from Freshwater Marsh and SoCal Gas Wells  
 Playa Vista

| Chemical          | Detected Concentration<br>( $\mu\text{g}/\text{m}^3$ ) | Risk-Based Concentration<br>( $\mu\text{g}/\text{m}^3$ ) |
|-------------------|--------------------------------------------------------|----------------------------------------------------------|
| Benzene           | ND (RL = 2.5)                                          | 60 (chronic)<br>(LA Area Background 1.9 to 2.8)          |
| Toluene           | 3.5                                                    | 37,000 (acute)<br>300 (chronic)                          |
| Ethylbenzene      | 5.3                                                    | 2,000 (chronic)                                          |
| Xylenes (m,p + o) | 20.5                                                   | 22,000 (acute)<br>700 (chronic)                          |
| Hydrogen Sulfide  | 11.6                                                   | 42 (acute)<br>10 (chronic)                               |
| N-Hexane          | ND (RL = 35,243)                                       | 7,000 (chronic)                                          |

All risk-based concentrations are Reference Exposure Limits (RELs) developed by the Office of Environmental Health Hazard Assessment (OEHHA) (<http://www.oehha.ca.gov/risk/ChemicalDB/index.asp>) for non-cancer effects, except as noted. Acute RELs are not available for benzene, ethylbenzene or n-hexane. However, acute criteria are always higher than chronic criteria. Thus, if chronic criteria are not exceeded, no acute threats are present.



**ISOTECH**<sup>®</sup>

www.isotechlabs.com mail@isotechlabs.com

Isotech Laboratories, Inc. 1308 Parkland Court Champaign, IL 61821-1826 Telephone 217/398-3490 FAX 217/398-3493

April 11, 2005

Michelle Zych  
Camp, Dresser & McKee, Inc.  
18581 Teller Avenue, Suite 200  
Irvine, CA 92612

Dear Michelle:

Enclosed are the analysis reports for the 3 gas samples recently submitted from the Playa Vista project. These samples were assigned to Isotech job number 5963. These are the same data that were emailed to you earlier. If you have any questions, or if there is anything else we can do for you, please do not hesitate to contact us.

We will hold the samples until 04/25/05 in case you should want any additional analyses carried out and will then dispose of the remaining sample material. If you need us to hold the samples longer, please contact us. I have also enclosed an invoice for this work and would appreciate it if you would pass it on to the appropriate office for processing. Thank you for choosing Isotech for your analysis needs, we appreciate your business.

Sincerely,

Steven R. Pelphrey  
Laboratory Manager

Enclosure

SRP:cw

# ANALYSIS REPORT

Lab #: 80836 Job #: 5963  
 Sample Name/Number: FWM-Bubble 1-031705  
 Company: Camp Dresser McKee, Inc.  
 Date Sampled: 3/17/2005  
 Container: Bottle  
 Field/Site Name: Playa Vista  
 Location: Playa Del Ray  
 Formation/Depth:  
 Sampling Point:  
 Date Received: 3/21/2005 Date Reported: 3/24/2005

| Component              | Chemical<br>mol. % | Delta 13C<br>per mil | Delta-D<br>per mil | Delta 15N<br>per mil |
|------------------------|--------------------|----------------------|--------------------|----------------------|
| Carbon Monoxide -----  | nd                 |                      |                    |                      |
| Hydrogen Sulfide ----- | nd                 |                      |                    |                      |
| Helium -----           | nd                 |                      |                    |                      |
| Hydrogen -----         | nd                 |                      |                    |                      |
| Argon -----            | 0.0671             |                      |                    |                      |
| Oxygen -----           | 0.502              |                      |                    |                      |
| Nitrogen -----         | 3.01               |                      |                    |                      |
| Carbon Dioxide -----   | 0.63               | -23.05               |                    |                      |
| Methane -----          | 95.55              | -60.72               | -198.8             |                      |
| Ethane -----           | 0.241              | -19.83               |                    |                      |
| Ethylene -----         | nd                 |                      |                    |                      |
| Propane -----          | 0.0030             |                      |                    |                      |
| Iso-butane -----       | nd                 |                      |                    |                      |
| N-butane -----         | nd                 |                      |                    |                      |
| Iso-pentane -----      | nd                 |                      |                    |                      |
| N-pentane -----        | nd                 |                      |                    |                      |
| Hexanes + -----        | nd                 |                      |                    |                      |

Total BTU/cu.ft. dry @ 60deg F & 14.7psia, calculated: 973  
 Specific gravity, calculated: 0.577

nd = not detected, na = not analyzed. Isotopic composition of carbon is relative to VPDB. Isotopic composition of hydrogen is relative to VSMOW. Calculations for BTU and specific gravity per ASTM D3588. Chemical compositions are normalized to 100%. Mol. % is approximately equal to vol. %.



**ISOTECH** Laboratories, Inc. 1308 Parkland Ct. Champaign, IL 61821 217/398-3490

# ANALYSIS REPORT

Lab #: 80837 Job #: 5963  
 Sample Name/Number: CDM-Vidor-17-031705  
 Company: Camp Dresser McKee, Inc.  
 Date Sampled: 3/17/2005 Cylinder: 2048  
 Container: 300 ml stainless  
 Field/Site Name: Playa Vista  
 Location: Playa Del Ray  
 Formation/Depth:  
 Sampling Point:  
 Date Received: 3/21/2005 Date Reported: 3/24/2005

| Component              | Chemical<br>mol. % | Delta 13C<br>per mil | Delta D<br>per mil | Delta 15N<br>per mil |
|------------------------|--------------------|----------------------|--------------------|----------------------|
| Carbon Monoxide -----  | nd                 |                      |                    |                      |
| Hydrogen Sulfide ----- | nd                 |                      |                    |                      |
| Helium -----           | 0.0058             |                      |                    |                      |
| Hydrogen -----         | nd                 |                      |                    |                      |
| Argon -----            | 0.0056             |                      |                    |                      |
| Oxygen -----           | nd                 |                      |                    |                      |
| Nitrogen -----         | 0.42               |                      |                    |                      |
| Carbon Dioxide -----   | 0.98               | 6.43                 |                    |                      |
| Methane -----          | 95.22              | -40.08               | -195.1             |                      |
| Ethane -----           | 2.51               | -27.55               |                    |                      |
| Ethylene -----         | nd                 |                      |                    |                      |
| Propane -----          | 0.561              |                      |                    |                      |
| Iso-butane -----       | 0.0843             |                      |                    |                      |
| N-butane -----         | 0.0920             |                      |                    |                      |
| Iso-pentane -----      | 0.0269             |                      |                    |                      |
| N-pentane -----        | 0.0207             |                      |                    |                      |
| Hexanes + -----        | 0.0776             |                      |                    |                      |

Total BTU/cu.ft. dry @ 60deg F & 14.7psia, calculated: 1036

Specific gravity, calculated: 0.588

nd = not detected. na = not analyzed. Isotopic composition of carbon is relative to VPDB. Isotopic composition of hydrogen is relative to VSMOW. Calculations for BTU and specific gravity per ASTM D3588. Chemical compositions are normalized to 100%. Mol. % is approximately equal to vol. %.



**ISOTECH** Laboratories, Inc. 1308 Parkland Ct. Champaign, IL 61821 217/398-3490

# ANALYSIS REPORT

Lab #: 80838 Job #: 5963  
 Sample Name/Number: CDM-Vidor-14-031705  
 Company: Camp Dresser McKee, Inc.  
 Date Sampled: 3/17/2005 Cylinder: 2058  
 Container: 300 ml stainless  
 Field/Site Name: Playa Vista  
 Location: Playa Del Ray  
 Formation/Depth:  
 Sampling Point:  
 Date Received: 3/21/2005 Date Reported: 3/24/2005

| Component              | Chemical<br>mol. % | Delta 13C<br>per mil | Delta D<br>per mil | Delta 15N<br>per mil |
|------------------------|--------------------|----------------------|--------------------|----------------------|
| Carbon Monoxide -----  | nd                 |                      |                    |                      |
| Hydrogen Sulfide ----- | nd                 |                      |                    |                      |
| Helium -----           | 0.0234             |                      |                    |                      |
| Hydrogen -----         | 0.0148             |                      |                    |                      |
| Argon -----            | 0.0183             |                      |                    |                      |
| Oxygen -----           | 0.169              |                      |                    |                      |
| Nitrogen -----         | 2.36               |                      |                    |                      |
| Carbon Dioxide -----   | 0.54               | -0.83                |                    |                      |
| Methane -----          | 90.56              | -42.16               | -171.4             |                      |
| Ethane -----           | 4.67               | -32.78               |                    |                      |
| Ethylene -----         | nd                 |                      |                    |                      |
| Propane -----          | 1.17               |                      |                    |                      |
| Iso-butane -----       | 0.104              |                      |                    |                      |
| N-butane -----         | 0.163              |                      |                    |                      |
| Iso-pentane -----      | 0.0405             |                      |                    |                      |
| N-pentane -----        | 0.0373             |                      |                    |                      |
| Hexanes + -----        | 0.127              |                      |                    |                      |

Total BTU/cu.ft. dry @ 60deg F & 14.7psia, calculated: 1049

Specific gravity, calculated: 0.612

nd = not detected. na = not analyzed. Isotopic composition of carbon is relative to VPDB. Isotopic composition of hydrogen is relative to VSMOW. Calculations for BTU and specific gravity per ASTM D3588. Chemical compositions are normalized to 100%. Mol. % is approximately equal to vol. %.



**ISOTECH** Laboratories, Inc. 1308 Parkland Ct. Champaign, IL 61821 217/398-3490



LABORATORY REPORT

Client: CAMP DRESSER & MCKEE, INC. Date of Report: 03/29/05  
Address: 18581 Teller Avenue, Suite 200 Date Received: 03/17/05  
Irvine, CA 92612 CAS Project No: P2500554  
Contact: Ms. Michele Zych Purchase Order: Verbal  
Client Project ID: Playa Vista

One (1) 1.0 Liter Plastic Bottle Samples labeled: "FWM-Bubble 1-031705"

Two (2) Tedlar Bag Samples labeled: "CDM-Vidor 17-031705" "CDM-Vidor 14-031705"

The samples were received at the laboratory under chain of custody on March 17, 2005. The client requested and received five day rush results. The samples were received intact. Please refer to the sample acceptance check form for additional information. The results reported herein are applicable only to the condition of the samples at the time that they were received at the laboratory.

Hydrogen Sulfide Analysis

The samples were analyzed for hydrogen sulfide per modified SCAQMD Method 307-91 and ASTM D 5504-01 using a gas chromatograph equipped with a sulfur chemiluminescence detector (SCD).

Reviewed and Approved:

Svetlana Walsh  
Analytical Chemist  
Air Quality Laboratory

Reviewed and Approved:

Wade Henton  
GC-VOA Team Leader  
Air Quality Laboratory

Page  
1 of 10

COLUMBIA ANALYTICAL SERVICES, INC.

RESULTS OF ANALYSIS

Page 1 of 1

Client: **Camp Dresser & McKee, Inc.**  
 Client Project ID: **Playa Vista**

CAS Project ID: **P2500554**

Hydrogen Sulfide

Test Code: **ASTM D 5504-01**  
 Instrument ID: **Agilent 6890A/GC13/SCD**  
 Analyst: **Zheng Wang**  
 Sampling Media: **Plastic Bottle(s)/Tedlar Bag(s)**  
 Test Notes:

Date(s) Collected: **3/17/05**  
 Date Received: **3/17/05**  
 Date Analyzed: **3/17/05**  
 Volume(s) Analyzed: **1.0 ml(s)**

| Client Sample ID    | CAS Sample ID | Date Analyzed | Time Analyzed | Hydrogen Sulfide            |                          |                |             | Data Qualifier |
|---------------------|---------------|---------------|---------------|-----------------------------|--------------------------|----------------|-------------|----------------|
|                     |               |               |               | Result<br>µg/m <sup>3</sup> | MRL<br>µg/m <sup>3</sup> | Result<br>ppbV | MRL<br>ppbV |                |
| FWM-Bubble 1-031705 | P2500554-001  | 3/17/05       | 15:49         | 11.6                        | 7.00                     | 8.34           | 5.00        |                |
| CDM-Vidor 17-031705 | P2500554-002  | 3/17/05       | 15:02         | 4.65                        | 7.00                     | 3.34           | 5.00        | J              |
| CDM-Vidor 14-031705 | P2500554-003  | 3/17/05       | 15:26         | ND                          | 7.00                     | ND             | 5.00        |                |
| Method Blank        | P050317-MB    | 3/17/05       | 09:39         | ND                          | 7.00                     | ND             | 5.00        |                |

ND = Compound was analyzed for, but not detected above the laboratory detection limit.

MRL = Method Reporting Limit - The minimum quantity of a target analyte that can be confidently determined by the referenced method.

J = The analyte was positively identified below the laboratory method reporting limit; the associated numerical value is considered estimated.

Verified By: RG Date: 3/24/05 **3**



**COLUMBIA ANALYTICAL SERVICES, INC.**

RESULTS OF ANALYSIS

Page 1 of 1

Client: **Camp Dresser & McKee, Inc.**  
 Client Sample ID: **FWM-Bubble 1-031705**  
 Client Project ID: **Playa Vista**

CAS Project ID: **P2500554**  
 CAS Sample ID: **P2500554-001**

Test Code: **Modified EPA TO-15**  
 Instrument ID: **Tekmar AUTOCAN/Agilent 5973inert/6890N/MS8**  
 Analyst: **Svetlana Walsh**  
 Sampling Media: **1 Liter Plastic Bottle**  
 Test Notes:

Date Collected: **3/17/05**  
 Date Received: **3/17/05**  
 Date(s) Analyzed: **3/18/05**  
 Volume(s) Analyzed: **0.20 Liter(s)**

D.F. = 1.00

| CAS#        | Compound            | Result<br>ug/m <sup>3</sup> | MRL<br>ug/m <sup>3</sup> | Result<br>ppbV | MRL<br>ppbV | Data<br>Qualifier |
|-------------|---------------------|-----------------------------|--------------------------|----------------|-------------|-------------------|
| 71-43-2     | Benzene             | ND                          | 2.5                      | ND             | 0.78        |                   |
| 108-88-3    | Toluene             | 3.5                         | 2.5                      | 0.92           | 0.66        |                   |
| 100-41-4    | Ethylbenzene        | 5.3                         | 2.5                      | 1.2            | 0.58        |                   |
| 136777-61-2 | <i>m,p</i> -Xylenes | 14                          | 5.0                      | 3.2            | 1.2         |                   |
| 95-47-6     | <i>o</i> -Xylene    | 6.5                         | 2.5                      | 1.5            | 0.58        |                   |

ND = Compound was analyzed for, but not detected above the laboratory reporting limit.

MRL = Method Reporting Limit - The minimum quantity of a target analyte that can be confidently determined by the referenced method.

Verified By: RL Date: 3/24/05

4

COLUMBIA ANALYTICAL SERVICES, INC.

RESULTS OF ANALYSIS

Page 1 of 1

Client: **Camp Dresser & McKee, Inc.**  
 Client Sample ID: **CDM-Vidor 17-031705**  
 Client Project ID: **Playa Vista**

CAS Project ID: **P2500554**  
 CAS Sample ID: **P2500554-002**

Test Code: **Modified EPA TO-15**  
 Instrument ID: **Tekmar AUTOCAN/Agilent 5973inert/6890N/MS8**  
 Analyst: **Svetlana Walsh**  
 Sampling Media: **Tedlar Bag**  
 Test Notes:

Date Collected: **3/17/05**  
 Date Received: **3/17/05**  
 Date(s) Analyzed: **3/18/05**  
 Volume(s) Analyzed: **0.00050 Liter(s)**

D.F. = 1.00

| CAS #       | Compound            | Result<br>µg/m <sup>3</sup> | MRL<br>µg/m <sup>3</sup> | Result<br>ppbV | MRL<br>ppbV | Data<br>Qualifier |
|-------------|---------------------|-----------------------------|--------------------------|----------------|-------------|-------------------|
| 71-43-2     | Benzene             | 58,000                      | 1,000                    | 18,000         | 310         |                   |
| 108-88-3    | Toluene             | 61,000                      | 1,000                    | 16,000         | 270         |                   |
| 100-41-4    | Ethylbenzene        | 6,300                       | 1,000                    | 1,500          | 230         |                   |
| 136777-61-2 | <i>m,p</i> -Xylenes | 25,000                      | 2,000                    | 5,800          | 460         |                   |
| 95-47-6     | <i>o</i> -Xylene    | 6,900                       | 1,000                    | 1,600          | 230         |                   |

ND = Compound was analyzed for, but not detected above the laboratory reporting limit.

MRL = Method Reporting Limit - The minimum quantity of a target analyte that can be confidently determined by the referenced method.

Verified By: RG

Date: 3/24/05

5

COLUMBIA ANALYTICAL SERVICES, INC.

RESULTS OF ANALYSIS

Page 1 of 1

Client: Camp Dresser & McKee, Inc.  
 Client Sample ID: CDM-Vidor 17-031705  
 Client Project ID: Playa Vista

CAS Project ID: P2500554  
 CAS Sample ID: P2500554-002DUP

Test Code: Modified EPA TO-15  
 Instrument ID: Tekmar AUTOCAN/Agilent 5973inert/6890N/MSS  
 Analyst: Svetlana Walsh  
 Sampling Media: Tedlar Bag  
 Test Notes:

Date Collected: 3/17/05  
 Date Received: 3/17/05  
 Date(s) Analyzed: 3/18/05  
 Volume(s) Analyzed: 0.00050 Liter(s)

D.F. = 1.00

| CAS #       | Compound            | Result<br>$\mu\text{g}/\text{m}^3$ | MRL<br>$\mu\text{g}/\text{m}^3$ | Result<br>ppbV | MRL<br>ppbV | Data<br>Qualifier |
|-------------|---------------------|------------------------------------|---------------------------------|----------------|-------------|-------------------|
| 71-43-2     | Benzene             | 57,000                             | 1,000                           | 18,000         | 310         |                   |
| 108-88-3    | Toluene             | 59,000                             | 1,000                           | 16,000         | 270         |                   |
| 100-41-4    | Ethylbenzene        | 5,800                              | 1,000                           | 1,300          | 230         |                   |
| 136777-61-2 | <i>m,p</i> -Xylenes | 23,000                             | 2,000                           | 5,300          | 460         |                   |
| 95-47-6     | <i>o</i> -Xylene    | 6,300                              | 1,000                           | 1,400          | 230         |                   |

ND = Compound was analyzed for, but not detected above the laboratory reporting limit.

MRL = Method Reporting Limit - The minimum quantity of a target analyte that can be confidently determined by the referenced method.

COLUMBIA ANALYTICAL SERVICES, INC.

RESULTS OF ANALYSIS

Page 1 of 1

Client: Camp Dresser & McKee, Inc.  
 Client Sample ID: CDM-Vidor 14-031705  
 Client Project ID: Playa Vista

CAS Project ID: P2500554  
 CAS Sample ID: P2500554-003

Test Code: Modified EPA TO-15  
 Instrument ID: Tekmar AUTOCAN/Agilent 5973inert/6890N/MS8  
 Analyst: Svetlana Walsh  
 Sampling Media: Tedlar Bag  
 Test Notes:

Date Collected: 3/17/05  
 Date Received: 3/17/05  
 Date(s) Analyzed: 3/18/05  
 Volume(s) Analyzed: 0.00025 Liter(s)

D.F. = 1.00

| CAS #       | Compound            | Result<br>$\mu\text{g}/\text{m}^3$ | MRL<br>$\mu\text{g}/\text{m}^3$ | Result<br>ppbV | MRL<br>ppbV | Data<br>Qualifier |
|-------------|---------------------|------------------------------------|---------------------------------|----------------|-------------|-------------------|
| 71-43-2     | Benzene             | 220,000                            | 2,000                           | 68,000         | 630         |                   |
| 108-88-3    | Toluene             | 280,000                            | 2,000                           | 74,000         | 530         |                   |
| 100-41-4    | Ethylbenzene        | 12,000                             | 2,000                           | 2,700          | 460         |                   |
| 136777-61-2 | <i>m,p</i> -Xylenes | 16,000                             | 4,000                           | 3,700          | 920         |                   |
| 95-47-6     | <i>o</i> -Xylene    | 4,800                              | 2,000                           | 1,100          | 460         |                   |

ND = Compound was analyzed for, but not detected above the laboratory reporting limit.

MRL = Method Reporting Limit - The minimum quantity of a target analyte that can be confidently determined by the referenced method.

Verified By: RC Date: 3/24/05

7

COLUMBIA ANALYTICAL SERVICES, INC.

RESULTS OF ANALYSIS

Page 1 of 1

Client: Camp Dresser & McKee, Inc.  
 Client Sample ID: Method Blank  
 Client Project ID: Playa Vista

CAS Project ID: P2500554  
 CAS Sample ID: P050318-MB

Test Code: Modified EPA TO-15  
 Instrument ID: Tekmar AUTOCAN/Agilent 5973inert/6890N/MS8  
 Analyst: Svetlana Walsh  
 Sampling Media: Tedlar Bag  
 Test Notes:

Date Collected: NA  
 Date Received: NA  
 Date(s) Analyzed: 3/18/05  
 Volume(s) Analyzed: 1.00 Liter(s)

D.F. = 1.00

| CAS #       | Compound     | Result<br>µg/m <sup>3</sup> | MRL<br>µg/m <sup>3</sup> | Result<br>ppbV | MRL<br>ppbV | Data<br>Qualifier |
|-------------|--------------|-----------------------------|--------------------------|----------------|-------------|-------------------|
| 71-43-2     | Benzene      | ND                          | 0.50                     | ND             | 0.16        |                   |
| 108-88-3    | Toluene      | ND                          | 0.50                     | ND             | 0.13        |                   |
| 100-41-4    | Ethylbenzene | ND                          | 0.50                     | ND             | 0.12        |                   |
| 136777-61-2 | m,p-Xylenes  | ND                          | 1.0                      | ND             | 0.23        |                   |
| 95-47-6     | o-Xylene     | ND                          | 0.50                     | ND             | 0.12        |                   |

ND = Compound was analyzed for, but not detected above the laboratory reporting limit.

MRL = Method Reporting Limit - The minimum quantity of a target analyte that can be confidently determined by the referenced method.

Verified By: RC

Date: 3/24/05

8

**Columbia Analytical Services, Inc.  
Sample Acceptance Check Form**

Client: Camp Dresser & McKee, Inc.

Work order: P2500554

Project: Playa Vista

Sample(s) received on: 3/17/05

Date opened: 3/17/05

by: SM

*Note:* This form is used for all samples received by CAS. The use of this form for custody seals is strictly meant to indicate presence/absence and not as an indication of compliance or nonconformity. Thermal preservation and pH will only be evaluated either at the request of the client or as required by the method/SOP.

- |    |                                                                                                           | Yes                                 | No                                  | N/A                                 |
|----|-----------------------------------------------------------------------------------------------------------|-------------------------------------|-------------------------------------|-------------------------------------|
| 1  | Were custody seals on outside of cooler/Box?                                                              | <input type="checkbox"/>            | <input checked="" type="checkbox"/> | <input type="checkbox"/>            |
|    | Location of seal(s)? _____ Sealing Lid?                                                                   | <input type="checkbox"/>            | <input type="checkbox"/>            | <input checked="" type="checkbox"/> |
|    | Were signature and date included?                                                                         | <input type="checkbox"/>            | <input type="checkbox"/>            | <input checked="" type="checkbox"/> |
|    | Were seals intact?                                                                                        | <input type="checkbox"/>            | <input type="checkbox"/>            | <input checked="" type="checkbox"/> |
|    | Were custody seals on outside of sample container?                                                        | <input type="checkbox"/>            | <input checked="" type="checkbox"/> | <input type="checkbox"/>            |
|    | Location of seal(s)? _____ Sealing Lid?                                                                   | <input type="checkbox"/>            | <input type="checkbox"/>            | <input checked="" type="checkbox"/> |
|    | Were signature and date included?                                                                         | <input type="checkbox"/>            | <input type="checkbox"/>            | <input checked="" type="checkbox"/> |
|    | Were seals intact?                                                                                        | <input type="checkbox"/>            | <input type="checkbox"/>            | <input checked="" type="checkbox"/> |
| 2  | Were sample containers properly marked with client sample ID?                                             | <input checked="" type="checkbox"/> | <input type="checkbox"/>            | <input type="checkbox"/>            |
| 3  | Did sample containers arrive in good condition?                                                           | <input checked="" type="checkbox"/> | <input type="checkbox"/>            | <input type="checkbox"/>            |
| 4  | Were chain-of-custody papers used and filled out?                                                         | <input checked="" type="checkbox"/> | <input type="checkbox"/>            | <input type="checkbox"/>            |
| 5  | Did sample container labels and/or tags agree with custody papers?                                        | <input checked="" type="checkbox"/> | <input type="checkbox"/>            | <input type="checkbox"/>            |
| 6  | Was sample volume received adequate for analysis?                                                         | <input checked="" type="checkbox"/> | <input type="checkbox"/>            | <input type="checkbox"/>            |
| 7  | Are samples within specified holding times?                                                               | <input checked="" type="checkbox"/> | <input type="checkbox"/>            | <input type="checkbox"/>            |
| 8  | Was proper temperature (thermal preservation) of cooler at receipt adhered to?                            | <input type="checkbox"/>            | <input type="checkbox"/>            | <input checked="" type="checkbox"/> |
|    | Cooler Temperature <u>NA</u> °C                                                                           |                                     |                                     |                                     |
|    | Blank Temperature <u>NA</u> °C                                                                            |                                     |                                     |                                     |
| 9  | Is pH (acid) preservation necessary, according to method/SOP or Client specified information?             | <input type="checkbox"/>            | <input checked="" type="checkbox"/> | <input type="checkbox"/>            |
|    | Is there a client indication that the submitted samples are pH (acid) preserved?                          | <input type="checkbox"/>            | <input type="checkbox"/>            | <input checked="" type="checkbox"/> |
|    | Were <u>VOA vials</u> checked for presence/absence of air bubbles?                                        | <input type="checkbox"/>            | <input type="checkbox"/>            | <input checked="" type="checkbox"/> |
|    | Does the client/method/SOP require that the analyst check the sample pH and <u>if necessary</u> alter it? | <input type="checkbox"/>            | <input type="checkbox"/>            | <input checked="" type="checkbox"/> |
| 10 | <b>Tubes:</b> Are the tubes capped and intact?                                                            | <input type="checkbox"/>            | <input type="checkbox"/>            | <input checked="" type="checkbox"/> |
|    | Do they contain moisture?                                                                                 | <input type="checkbox"/>            | <input type="checkbox"/>            | <input checked="" type="checkbox"/> |
| 11 | <b>Badges:</b> Are the badges properly capped and intact?                                                 | <input type="checkbox"/>            | <input type="checkbox"/>            | <input checked="" type="checkbox"/> |
|    | Are dual bed badges separated and individually capped and intact?                                         | <input type="checkbox"/>            | <input type="checkbox"/>            | <input checked="" type="checkbox"/> |

| Client Sample ID | Received<br>By | pH<br>(if preserved/required) | VOA Headspace<br>(Presence/Absence) | Receipt/Preservation<br>Comments |
|------------------|----------------|-------------------------------|-------------------------------------|----------------------------------|
| P2500554-001     |                |                               | NA                                  |                                  |
| P2500554-001B    |                |                               | NA                                  |                                  |
| P2500554-001C    |                |                               | NA                                  |                                  |
| P2500554-001D    |                |                               | NA                                  |                                  |
| P2500554-002     |                |                               | NA                                  |                                  |
| P2500554-002B    |                |                               | NA                                  |                                  |
| P2500554-003     |                |                               | NA                                  |                                  |
| P2500554-003B    |                |                               | NA                                  |                                  |
|                  |                |                               |                                     |                                  |
|                  |                |                               |                                     |                                  |

Explain any discrepancies: (include lab sample ID numbers): \_\_\_\_\_



**Air Quality Laboratory**  
 2665 Park Center Drive, Suite D  
 Simi Valley, California 93065  
 Phone (805) 526-7161  
 Fax (805) 526-7270

**Chain of Custody Record & Analytical Service Request**

Requested Turnaround Time by Close of Business Day (Surcharges) Please Circle:  
 1 Day (100%) 2 Day (75%) 3 Day (50%) 4 Day (35%) 5 Day (15%) 6 Day Standard

CAS Project No.  
R2500554

Reporting Information (Company Name & Address)  
**CDM, Inc.**  
 18581 Teller Ave, Suite 200  
 Irvine, CA 92612  
 Attention: **Michelle Zych**  
 Phone **949-752-5452** Fax **949-752-1307**

P.O. # / Billing Information

Project Name  
**Playa Vista**

Project Number

CAS Contact:

**Analysis Method and/or Analytes**

Comments  
 e.g. Preservative or  
 specific instructions

Email Address for Result Reporting

Sampler (Print & Sign)  
**Scott A. Sanderson Scott A. Sanderson**

| Client Sample ID                | Date Collected     | Time Collected | Lab Sample No. | Sample Type (Air/Liquid/Solid/Tube) | Canister ID (Bar Code #) | Flow Controller (Bar Code #) | Sample Volume | Analysis Method and/or Analytes |                  | Comments                 |
|---------------------------------|--------------------|----------------|----------------|-------------------------------------|--------------------------|------------------------------|---------------|---------------------------------|------------------|--------------------------|
| FWM-Bubbler-031705              | 3/17/05            | 940            |                | Air                                 |                          |                              |               | BTEX                            | H <sub>2</sub> S | 4 bottles                |
| <del>FWM-Bubbler-031705</del>   | <del>3/17/05</del> |                |                | <del>Air</del>                      |                          |                              |               | <del>✓</del>                    | <del>✓</del>     | <del>4 bottles</del>     |
| CDM-Vidor 17-031705             | 3/17/05            | 1220           |                | Air                                 |                          |                              |               | ✓                               | ✓                | 2 tedlar bags            |
| <del>CDM-Delroy 17-031705</del> | <del>3/17/05</del> |                |                | <del>Air</del>                      |                          |                              |               | <del>✓</del>                    | <del>✓</del>     | <del>2 tedlar bags</del> |
| CDM-Vidor 14-031705             | 3/17/05            | 1140           |                | Air                                 |                          |                              |               | ✓                               | ✓                | 2 tedlar bag             |

Report Tier Levels - please select  
 Tier I - (default if not specified) \_\_\_\_\_ Tier III (QC, Raw Data, Spectra) 10% Surcharge  
 Tier II (QC forms) \_\_\_\_\_ Other \_\_\_\_\_ EDD required Yes / No Type: \_\_\_\_\_

Project Requirements (MRLs, QAPP)

|                                                           |                         |                      |                                                |                         |                          |
|-----------------------------------------------------------|-------------------------|----------------------|------------------------------------------------|-------------------------|--------------------------|
| Relinquished by: (Signature)<br><b>Scott A. Sanderson</b> | Date:<br><b>3/17/05</b> | Time:<br><b>1230</b> | Received by: (Signature)<br><b>[Signature]</b> | Date:<br><b>3/17/05</b> | Time:<br><b>12:35 PM</b> |
| Relinquished by: (Signature)<br><b>[Signature]</b>        | Date:<br><b>3/17/05</b> | Time:<br><b>1402</b> | Received by: (Signature)<br><b>[Signature]</b> | Date:<br><b>3/17/05</b> | Time:<br><b>2:05</b>     |
| Relinquished by: (Signature)<br><b>[Signature]</b>        | Date:                   | Time:                | Received by: (Signature)                       | Date:                   | Time:                    |

Cooler / Blank Temperature \_\_\_\_\_ °C

Report to  
**City of Los Angeles**  
**Department of Building and Safety**  
201 North Figueroa Street  
Los Angeles, CA 90012-2827

on

**Playa Vista Development**  
**Playa Vista, California**

**Comparison of Gas Analyses from  
Southern California Gas Company  
Injection and Observation Wells with  
Soil Gas and Groundwater Gas from 50ft Gravel Aquifer**

by

Isaac R. Kaplan  
ZymaX forensics, Inc.  
16921 Parthenia Street, Suite 201  
North Hills, CA 91343

Robert Poreda  
Department of Earth and Environmental Sciences  
University of Rochester  
Rochester, NY 14627

January 29, 2001



Figure 7

A site map of the Playa Vista site showing the locations and helium isotope ratios of the injection (half-filled squares) and observation gas (half-filled circles) wells, and monitoring wells (solid circles).

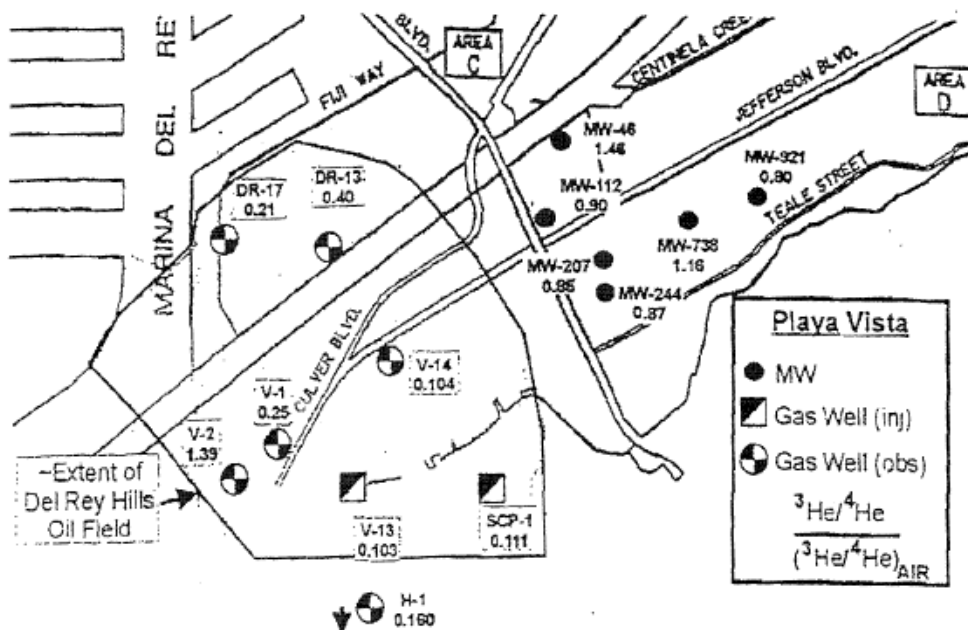

CR39

~~CONFIDENTIAL~~  
PDR 1103

INTEROFFICE



CORRESPONDENCE

TO Mrs. Shahed Meskati FROM E. S. Sinclair DATE March 3, 1987  
SUBJECT Storage Gas Migration to Well Troxel

Introduction

During parts of December and November 1986, Wells Del Rey 18 and Del Rey 10 were shut-in for several weeks. Del Rey 18 was shut-in because of different maintenance problems while Del Rey 10 was accidentally left shut-in.

Del Rey 15 is generally put on withdrawal as an alternate if Del Rey 18 is expected to be shut-in for more than two days, and concurrently with Del Rey 18 if the field pressure is above 1250 psig.

Del Rey 18 and 15 are gas migration return wells, which collect migration gas to the northwest of the main storage area.

Del Rey 10 is presently used as an observation and also as a migration gas collection well, even though it has a Reda submersible pump presently installed in it. The well is normally shut-in with the casing left open to the Marina low pressure gas collection system.

Common belief is that Troxel is not contiguous to any sections of the storage field. However, it is used to create a pressure sink and to collect gas and liquids in the Marina beach area, fluids which would otherwise probably show up in old abandoned wells which are scattered throughout that area. A recent geological study of the Playa del Rey storage field by Richard L. Hester was not able to clearly deny or agree with the common belief.

Consultants, Stanley and Stolz in 1958 submitted memorandum to the Gas Company which discussed gas migration to the Marina townlot wells. They said the 8-inch line to Del Rey 18 was very effective in reducing the migration gas reaching the townlot wells (which at that time were; Davidson #4, Blocks 10R and 11 and Townsite 2 and 11). However, they discovered that during the winter season when more gas was injected into the main storage area the migration gas to the townlot wells seemed to increase. Stanley and Stolz recommendation, based on the winter observation, was for the Gas Company to acquire complete control of the above mentioned townlot wells.

A consequent memorandum by the consultants was published in 1961 addressing the aquisition of Troxel #1. They stated that with the aquisition of Union Oil Company and Block Oil Company properties the former migration problem is apparently under control. The consultants further stated that although positive helium traces were never evident and faulting might separate Troxel from the Company's holdings, Troxel should not be placed in an unimportant category. They said it would fit nicely into Company operations and would be excellent for observation purposes. Stanley and Stolz later recommended that the Gas Company acquire Troxel #1.

### Discussion

During the November/December '86 shut-in of the two gas cap wells and Del Rey 10, significant pressure increase was observed at Del Rey 10 (see graph). Del Rey 10 was accidentally left shut-in and the gas could not be relieved at that well. During this same period a gas sample was taken at Troxel and analyzed for helium. The analysis showed a higher helium content than is usual at this well. Helium analysis on Troxel in November '84 and May '86 showed 15 ppm and 20 ppm respectively, while analysis in December '86 showed 84 ppm.

Gas production at Troxel also doubled during the said two months, November and December of '86 and returned to normal production January '87, after the Del Rey gas cap wells and Del Rey 10 were returned to normal operation. If these increases are due to migrated gas, the Company might be losing money in royalty payments. Furthermore, we might need to take more precaution in preventing high pressure migration gas into this sensitive townlot area.

### Conclusion

Although the higher than normal helium concentration and gas production at Troxel during the shut-in of Del Rey 18, 15 and 10 might not be enough evidence to conclusively state that there is gas cap gas migration to Troxel, they certainly are good indications.

Since the Playa del Rey field pressure is usually below 1250 psig., significant variations in migration gas might not be observed until the pressure increases beyond 1250 psig. During November '86 average field pressure was close to 1250 psig. which might be additional reasons for increased helium concentration and gas production in Troxel.

### Recommendation

I think monitoring of gas migration to the Townsite area (including Troxel) should be reviewed for effectiveness. The monitoring program should also be structured to detect and determine whether there is continuous migration to Troxel, intermittent migration or any migration at all.

However, for the present time I am recommending the following monitoring and operation procedures, both to monitor and reduce any gas migration to Troxel, the block wells and Townsite wells. In conjunction with present monitoring and operation:

1. Concurrently produce Del Rey 15 and 18 at all field pressures.

Recommendation (cont'd)

2. Investigate Del Rey 19 condition and put on production as soon as possible. Based on Hester Geological Study, Del Rey 19 will be a more useful migration gas return well than Del Rey 15 since it intersects the migration path.
3. Make special efforts to have all Townsite wells, block wells and Troxel on production at all times.
4. Continue to vent the casing at Del Rey 10 in the Marina low pressure system.
5. Compare monthly gas production from all townlot wells with average monthly main storage area pressure.
6. Quarterly, analyse gas sample from Troxel for helium.
7. Analyse gas sample from Troxel for helium as required, if main storage area field pressure increases above 1250 psig. and remains at that pressure more than three days.
8. Prepare quarterly reports on possible gas migration to Troxel.

We will be endeavouring to put the above recommendations into effect one week from the date of this memo, unless you or the copied list have concerns on any of the recommendations. I must also mention that these recommendations will only be in effect as long as they are necessary and prove to enhance understanding of the problem.

EES:dt

cc: J. P. Anand  
J. H. Joslin  
J. F. Tierney  
R. W. Weibel  
D. Zuniga

INTEROFFICE



CORRESPONDENCE

R-1  
2 NEW PHS R-1  
EACH WELL

TO Memo to File FROM R. D. Phillips <sup>B</sup> DATE Nov. 13, 1989  
SUBJECT Playa del Rey

From conversation with Bob Hazel.

- L-1 and F-1 can double deliverability by fixing downhole safety system.
- 27-1 and 29-1 used to be good flowing wells. Bob saw a definite drop in deliverability after an attempt was made to pump condensate into the wells. His theory is that water was in the kill system lines through which the condensate was pumped. The weight of the water and condensate in addition to the pumping pressure caused the tarry substance in the near wellbore region (which was to be loosened by the condensate) to be forced back into the formation. This blocked flow paths resulting in the deliverability loss.
- 29-1 and 29-2 were acidized in the early 80's. Acid caused formation damage.

RDP:hr

CA. Public Utilities Safety  
Report

**Complaint Case Facts and Findings  
(Playa Del Rey Storage Field)**

By

**Consumer Protection and Safety Division**

**August 20, 2002**

**Revised on November 18, 2004**

## Table of Contents

|                                 | Page          |
|---------------------------------|---------------|
| Introduction & Background       | 1             |
| Discussions of Facts & Findings | 2-6           |
| Recommendations                 | 7             |
| Appendices                      | A, - D, F & M |

## **I Introduction**

This report presents some of the data that Consumer Protection and Safety Division (CPSD) has gathered from the investigation of the Complaint Case (C.00-05-010) proceedings. On May 11, 2000, three residents of Playa Del Rey area filed similar complaints against SoCalGas, C.00-05-010, C.00-05-011 and C.00-05-012, respectively. In addition, Grassroots Coalition and several other residents of Playa del Rey (PDR) and Marina del Rey joined the complaints. Although the complaints were filed separately and individually, they shared a common concern that SoCalGas is operating its Playa Del Rey gas storage facility unsafely, in a manner hazardous to the health and safety of nearby homeowners. Specifically, the complainants alleged the storage reservoir was leaking, resulting in dangerous toxic pollution from venting and leaking gas, atmospheric contamination, noxious odors, and a leaking abandoned well. Each complainant asked the CPUC to conduct an investigation of the SoCalGas Storage facilities in Playa Del Rey.

SoCalGas filed a motion to dismiss these cases or consolidate the cases. Although the Commission denied the motion to dismiss the cases, but the motion to consolidate was granted and the three complaints were consolidated under Rule 55 of the Commission's Rules of Practice and Procedure. These three cases are now treated as one case under C.00-05-010.

CPSD investigations focused on all the allegations. During the course of these investigations, CPSD conducted laboratory analysis (Isotopic Analysis) of field samples from leaking abandoned well. CPSD also requested and reviewed large volume of data from SoCalGas and Grassroots Coalition. After review of all available data provided to CPSD, the findings were used to determine the merit of the allegations and consequently resolved some of the allegations. The remaining unresolved allegations have been classified into two issues: (1) Any evidence of PDR storage gas and/ or Thermogenic gas within SoCalGas mineral rights migrating to the surface, (2) Any evidence that the PDR Gas Treatment and/ or PDR Gas Storage facilities are contributing to local



residents' exposure to carcinogenic toxins. This report focuses on some of the data CPSD has collected, implications of our findings to date, and recommendations for resolving the two remaining allegations.

## II. Discussions of Facts and Findings

One must remember that the following facts and findings do not definitively explain or answer the allegations. However, this information, individually or cumulatively, indicate that there might be potential problems that warrant further investigation. The type of investigation or study scope must consider the available data, along with how to integrate that data into a full reservoir study and a Health Risk Assessment (HRA) that provides definitive results that lead to resolution of the two outstanding allegations. It is important to note facts and findings presented below do not indicate any wrong doing on the part of SoCalGas. Instead, they simply reflect the existence of potential hazards compounded by lack of definitive test results or data gaps. The following facts are discussed below:

- (a) Evidence of three types of natural gas in PDR
- (b) 133 PPM Helium in a natural gas sample from a bar hole near Big Ben well
- (c) 22 PPM Helium from a shallow probe by John Sepich & Assoc.,
- (d) Greater than 800 PPM Helium from groundwater samples
- (e) ETI report indicated Thermogenic gas components detected in shallow subsurface geologic units and H<sub>2</sub>S detected in soil gas samples
- (f) Previous reservoir inventory analysis
- (g) 50,000 PPM gas detected at Troxel Well and known migration loss to well
- (h) Potential problems with validity of some SoCalGas data.

City docs

### A. Three types of natural gas in PDR

There is evidence of surface detection of three types of natural gas in PDR namely: Biogenic gas, Native PDR Thermogenic gas and Storage Reservoir

Thermogenic gas. Biogenic gas is commonly known as Swamp gas. Its chemical and physical characteristics are mostly Methane gas, formed by bacteria action in shallow surface. It has *no* Helium, Ethane, Butane or other heavier hydrocarbon. Biogenic gas is non jurisdictional. In contrast, Native PDR Thermogenic gas (native PDR gas) and Storage Reservoir Thermogenic gas (Storage gas) are formed by decomposition of prehistoric fossils under high temperature and pressure in deep and intermediate geological zones. Thermogenic gases have, Methane, Ethane, Helium and other hydrocarbons. Both native thermogenic and storage reservoir thermogenic gases have some identical physical and chemical characteristics contain varying amounts of Helium, Ethane, Methane and other hydrocarbons. Unfortunately, these identical characteristics make it difficult to differentiate Native PDR gas from Storage Reservoir gas. However, experts like Dr. Archart (Department of Geological Sciences, University of Nevada) have discovered some subtle differences such as the difference in Helium content and the age of the Helium. There are evidence from various gas sample tests and isotopic analysis that show each of these three gases emanating to the ground surface at various locations at one time or another. The presence of Ethane, Methane, Helium and other hydrocarbons are one of the key considerations in determining if a sample is Biogenic or Thermogenic. Once it is determined that a sample is Thermogenic, then the Helium and the concentration present in that sample determines if it's Native PDR gas (1-15 PPM Helium) or Storage Reservoir gas (15-450 PPM Helium). However, commingling of these gases, alteration of physical and chemical properties by some external factors, and filtration of some gas constituents (possibly by groundwater or aquifer) obscure the minor differences and complicates the chemical speciation. *Please see Appendix # A*

**R. 133 PPM Helium from bar hole samples near Big Ben Well**

SoCalGas internal office memorandum, dated November 20, 1991 revealed that gas samples collected from bar-holes around Big Ben Well contained 30,000 PPM to 620,000 PPM natural gas and these samples contained 133 PPM to 188 PPM

Helium. A close examination of the memo revealed that three samples were collected on 1/11/91, at bar-holes # 12, 13 & 14. Isotopic analysis of these samples indicated with high probability the signature of Storage Reservoir gas (meaning that the gas migrated from Storage Reservoir). In addition, the memo did not indicate any more sampling at these bar-holes or subsequent remedial action. On 8/23/91 and subsequent dates, samples were collected from bar-hole H instead of bar-holes 12, 13 & 14. The isotopic analyses of the new samples did not reveal the storage gas signature and subsequent discussion on the memo ignored the initial sample data, its significance and if there was any remedial action. *Please see Appendix # B*

**C. 22 PPM Helium from a shallow probe sample by John Sepich and Associate.**

Isotech Laboratory performed an isotopic analysis of a gas sample submitted by Sepich & Associates on 3/25/99. Sepich and Associates was working for Playa Vista developers (developers of residential and business properties around the PDR Storage field. The isotopic analysis report indicates the gas sample was collected from Playa Vista Project Area-D. The analysis report also revealed presence of Ethane and 22 PPM Helium in the gas sample. The significance of this isotopic analysis report is the presence Storage Reservoir gas or Native PDR gas signature and the location where the gas sample was collected (Area - D of Playa Vista Project). My opinion is that the probability of Storage Reservoir gas sample from PDR area containing Ethane and 22 PPM Helium is greater than 50 percent (>50%). Furthermore, the location where the sample was collected should be of major concern. *Please see Appendix # C*

**D. 100 PPM-1000 PPM Helium from groundwater samples collected and analyzed by Exploration Technologies, Inc (ETI)**

City of Los Angeles Building and Safety Department retained ETI to conduct test, analyze and provide advice on Playa Vista project. Groundwater samples were collected in 2000 from Playa Vista Project Area, and dissolved

gases were extracted and analyzed by ETI in addition to other scientific sampling and testing. Several groundwater samples revealed presence of high Helium concentrations and methane dissolved in the groundwater. The origin of this Helium in the groundwater is not clear. However, some people have postulated that the groundwater absorbs or strips the Helium from the Storage Reservoir gas or Native PDR gas as it migrates through the aquifer to the ground surface. Hence, Thermogenic gas is detected in soil-gas without Helium. Although, this postulation seems plausible, I have not seen any scientific paper on this absorption theory and the kinetics. *Please see Appendix # D*

**E. Dr Victor Jones of ETI detected Thermogenic gas components at the surface and detected H<sub>2</sub>S in soil gas during his investigation in 2000.**

ETI conducted an extensive soil gas investigation in Playa Vista area for the City of Los Angeles in 2000. The isotopic analysis report of the samples collected revealed presence of Methane, Ethane, Helium, H<sub>2</sub>S, Toluene and other volatile organic compounds (voc). The presence of numerous Thermogenic gas components in the shallow soil gas samples analyzed indicates a deeper source for this gas.

**F. Previous Reservoir Inventory Verification Analysis by SCG indicated gas migration loss (8/22/80)**

A Reservoir Inventory Verification Analysis conducted by Theodoros Georgakopoulos on August 22, 1980, for SoCalGas indicated gas migration loss. The migration pathways to the Townsite area (separate geologic zone) is unknown. The report estimated storage reservoir gas loss between January 1961 and December 1979 to be 0.10 B.c.f. Subsequent reports estimated the gas loss to have decreased. *Please see Appendix # F*

### **G. Presence of Methane gas around Troxel Well.**

As part of Energy Division (ED) initial preliminary investigation, ED retained MHA, who subcontracted Giroux & Associates to conduct site investigations at the Troxel and Lor Mar well site locations in 2001. These recent studies found very high methane concentrations (greater than 50,000 ppm) at the Troxel site and low methane concentrations (1 to 6 ppm) at the Lor Mar site.

Although high methane levels at Troxel dissipated over time, low methane levels persisted through the end of the 32 days study period. This indicates a possible source of methane at this location. Methane concentrations also fluctuated during the study period, indicating that external factors (atmospheric pressure, tidal influences, gas storage reservoir operations) may be affecting data measurements. However, a soil gas survey study requested by the Commission and conducted by SoCalGas' consultant, TRC concluded that there were no measurable concentrations of volatile or combustible compounds encountered in the soil gas. Also, the study detected presence of Hydrogen Sulfide and the source was unknown. But recent sampling by Energy Division's CEQA team reported measurable concentrations volatile hydrocarbons.

### **H. Validity of SoCalGas Data.**

Data collected by SoCalGas may be flawed. Procedures used by SoCalGas to collect gas samples at the Troxel did not follow standard gas collection and sample handling procedures established by Federal Environmental Protection Agency and other trade associations. A plastic sheet was used to accumulate enough gas to collect samples for analysis. Samples were collected in plastic bottles. Since plastic is permeable to many gases, and may also absorb some hydrocarbon based gases, test results would not fully characterize gas emitted from the well.

Although bar hole testing is acceptable for Department of Oil Gas & Geothermal Resources leak detection requirement, it does not follow standard procedures established

for soil gas investigations. Soil is disturbed and compacted when the bar is driven into the ground. This could interfere with movement of some soil gas. Therefore, low levels of methane may not be detected and concentrations reported may not be valid.

### III. Recommendations

A review of the aforementioned facts and findings suggest the existence of a potential safety hazard. Since the available geological data does not definitively support or disprove the existence of safety hazard in and around the storage reservoir, further investigation and study is needed. It is important and recommended that CPSD conduct (1) comprehensive reservoir study and (2) Health Risk Assessment (HRA) (HRA that is not limited to "for sale lots" and integrate some of the data gathered from the CEQA study). The basis for this recommendation are in response to allegations of hazards to public health and Safety, potential ratepayer liability, lack of definitive results from available data and mandate from General Order 58-A, section 22. We recommend a reservoir study that will include but not limited to:

- 1) Construction of a 3-dimensional geologic computer model (Earth Vision or equivalent) using existing data (wells records, soil gas investigations, geo-technical borings, geophysical data, environmental borings, site contamination data, groundwater data, etc) to fully integrate and visually display geologic data (strata and discontinuities) and other subsurface information (gas and groundwater locations) at the storage field.
- 2) Drill a minimum of three shallow well observation wells to describe the stratigraphic conditions (visual and geophysical logging) in geologic deposits above 1000 feet elevation in order to define potential gas storage zones and migration pathways, and to collect gas samples from depths below biogenic sources.
- 3) Collect and analyze (isotopic and chemical analysis) the gas in geologic deposits from these wells, focusing on depths below

minus 500 feet elevation (below sea level), in order to determine the origin and genesis of the gas.

- 4) Integrate the results from items 1, 2 and 3 above to develop a logical, defensible subsurface model that explains the surface and subsurface gas detections and the potential pathways for gas to reach the surface environment.
- 5) Retain an expert to perform Helium Ratio Analysis.



A Semptra Energy company  
Energy Transportation Services

## Interoffice Memo

TO: John Thompson  
FROM: Leigh Brewer JB  
DATE: May 25, 2001  
SUBJECT: Biogenic Gas Found in Barhole V 3 near Mariner's Village in Marina Del Rey

EAC PROJECT#: TS01-C073  
EAC ACCOUNT#: 814 GP

### Objective

To determine the source of the soil gas sample recovered from the barhole, V 3, near Mariner's Village at Marina Del Rey.

### Findings and Conclusions

- ◆ It appears that the small amount of soil gas (2.1% to 2.8%) recovered from the barhole, V 3, near Mariner's Village, is bacterially degraded biogenic gas and is not from the Playa Del Rey Storage Field as shown by, the lack of heavier hydrocarbons, the lack of helium and the isotope ratios (see Table 1).
- ◆ The shallower of the two V 3 gas samples (8' versus 15'), taken on 9/22/00, has both a heavier carbon isotope ratio ( $\delta^{13}\text{C}$ ) and a heavier deuterium ratio ( $\delta\text{D}$ ) in methane. Since isotope ratios for samples taken from the same barhole, at the same time, should have the same value, bacterial degradation of the soil gas has probably taken place as shown on the table below and on the attached Figure 1.

| <u>Location</u>           | <u>Sample Date</u> | <u>Isotope Ratios in Methane</u>        |                                    |
|---------------------------|--------------------|-----------------------------------------|------------------------------------|
|                           |                    | <u><math>\delta^{13}\text{C}</math></u> | <u><math>\delta\text{D}</math></u> |
| V 3 - 8' deep             | 9-22-00            | -41.2 ‰                                 | -110 ‰                             |
| V 3 -15' deep             | 9-22-00            | -51.4 ‰                                 | -129 ‰                             |
| V 3 - surface             | 4-18-01            | -40.5 ‰                                 | -119 ‰                             |
| Playa Del Rey Storage gas | 11-93 to 10-00     | -42.6 ‰                                 | -193 ‰                             |

### Mariner Village Sampling

Last September, Sierra Labs under the direction of James Farrow, of Komex, collected two soil gas samples in Marina Del Rey near Mariner's Village. Both were taken from the barhole, V 3, one from 8' and a second from 15' deep. Komex collected a third sample from the surface of V 3 on 4/17/01. The gas concentrations were 2.16%, 2.10% and 2.81% respectively. All three samples had to be aspirated to collect enough volume for analysis. Besides methane, Zymax reported just 10



ppm of ethane in the two 9/00 samples (attached). No helium and only methane was found in the third sample, see attached Table 1.

Also on 4/17, Storage personnel performed a Flame Ionization survey around V 3 and found no combustible gas. In addition, on 4/5/01, Storage personnel checked the Komex barholes V 3 and V.13 (near Del Rey 6, an abandoned well), and found only 200 ppm of gas in V 3.

The Gas Company has tested natural gas in the Playa Del Rey area from gas storage wells, various barholes and several abandoned wells. Usually, the hydrocarbon and helium contents provide sufficient information to identify the gas source. In more difficult situations, isotope ratios in methane can provide further information.

### Isotopic Analysis and Soil Gas Degredation

The  $\delta^{13}\text{C}$  and  $\delta\text{D}$  in methane can contribute additional clues to source identification. However, bacterial degradation can alter these ratios, making them heavier. Although bacterially altered biogenic (swamp gas) methane may have  $\delta^{13}\text{C}$  values similar to thermogenic (example: older Storage gas) methane, the  $\delta\text{D}$  will differ. Degredation is especially likely if the methane concentrations are low (as per a phone conversation on 4/18/01 with Steve Wilkerson of Zymax).

The  $\delta^{13}\text{C}$  and  $\delta\text{D}$  ratios are often plotted against each other to help identify sources and degradation issues as discussed in Dennis Coleman's attached paper, "Advances in the Use of Geochemical Fingerprinting for Gas Identification". For the Marina Del Rey area, it appears that the  $\delta\text{D}$  of fresh, unaltered methane, be it biogenic or thermogenic, has a maximum value of  $-185\text{‰}$ , whereas the near surface degraded gas is  $-150\text{‰}$  or more as shown on the attached Figure 1.

On 2/12/98, CDM took several soil gas samples on the nearby Playa Vista property. Their average isotope values of  $-42.6\text{‰}$  for  $\delta^{13}\text{C}$  and  $-147\text{‰}$  for  $\delta\text{D}$ , indicate some degradation. The V 3 samples with an average of  $-44.3\text{‰}$  and  $-119\text{‰}$  respectively, indicate even greater degradation.

In contrast, gas sampled from abandoned wells in the Venice and Marina Del Rey area have had a  $\delta^{13}\text{C}$  as low as  $-73\text{‰}$  (Townsite 3 - 2/26/98). And, the unaltered biogenic gas found in the surface casing of the well, Del Rey 18 open at 750', has a  $\delta^{13}\text{C}$  of  $-69\text{‰}$  and a  $\delta\text{D}$  of  $-218\text{‰}$ . Storage gas has an average of  $-42.6\text{‰}$  and  $-193\text{‰}$  respectively.

Figure 1 shows how tightly grouped the isotope ratios of Storage gas are. However, the seep samples are spread over a wider area of the graph, owing to degradation issues.

### Methods

James Farrow provided the information regarding the 9/22/01 sample results. Komex performed the 4/17/01 V3 sampling and gave a split of the sample to Gas Co. personnel. The 4/17 sample was analyzed by the EAC for helium and hydrocarbon content then sent to Zymax for isotopic analysis. See the attached reports and Coleman's paper for more information.

### Attachments

cc: Jim Mansdorfer  
Joyce Padleschat

Jim Wine  
Dan Meltzer

Steve Reed  
Bruce Evans

*EMSR - OCT 1997*

**Figure 1 Carbon Isotope Ratio vs. Deuterium Ratio in Methane  
Marina Del Rey and Playa Del Rey**

| Date   | Sample location and depth: | d13C in methane | deuterium in methane |             |                  | Who Collected       |
|--------|----------------------------|-----------------|----------------------|-------------|------------------|---------------------|
|        |                            |                 | Ballona Cr. seep gas | PDR Storage | Mariners Village |                     |
| Nov-93 | Centinela Cr Ave.          | -50.875         | -180                 |             |                  | Global Geochemistry |
| Nov-93 | PDR Line 1159              | -42.92          |                      | -185.5      |                  | Global Geochemistry |
| Apr-96 | PDR Line 1167              | -42.0           |                      | -199        |                  | So Cal Gas          |
| Feb-98 | Playa Vista: SG 1-3'       | -51.86          | -144                 |             |                  | CDM                 |
| Feb-98 | Playa Vista: SG 2-5'       | -49.41          | -125                 |             |                  | CDM                 |
| Feb-98 | Playa Vista: SG 2-9'       | -50.17          | -132                 |             |                  | CDM                 |
| Feb-98 | PV: SG 2-9':Ground water   | -48.72          | -135                 |             |                  | CDM                 |
| Feb-98 | Playa Vista: SG 3-3'       | -58.09          | -195                 |             |                  | CDM                 |
| Feb-98 | Playa Vista: SG 4-0'       | -39.95          | -150                 |             |                  | CDM                 |
| Sep-00 | Mariners Village V 3-15'   | -51.44          |                      |             | -129             | Sierra Labs         |
| Sep-00 | Mariners Village V 3-8'    | -41.16          |                      |             | -110             | Sierra Labs         |
| Oct-00 | seep at Block 11           | -64.00          | -224                 |             |                  | So Cal Gas          |
| Oct-00 | Fast 1                     | -42.78          |                      | -193        |                  | So Cal Gas          |
| Oct-00 | SCP 1                      | -41.72          |                      | -196        |                  | So Cal Gas          |
| Apr-01 | DR 18 sfc csg              | -68.65          | -218                 |             |                  | So Cal Gas          |
| Apr-01 | Mariners Village V 3-0'    | -40.52          |                      |             | -119             | Komex               |

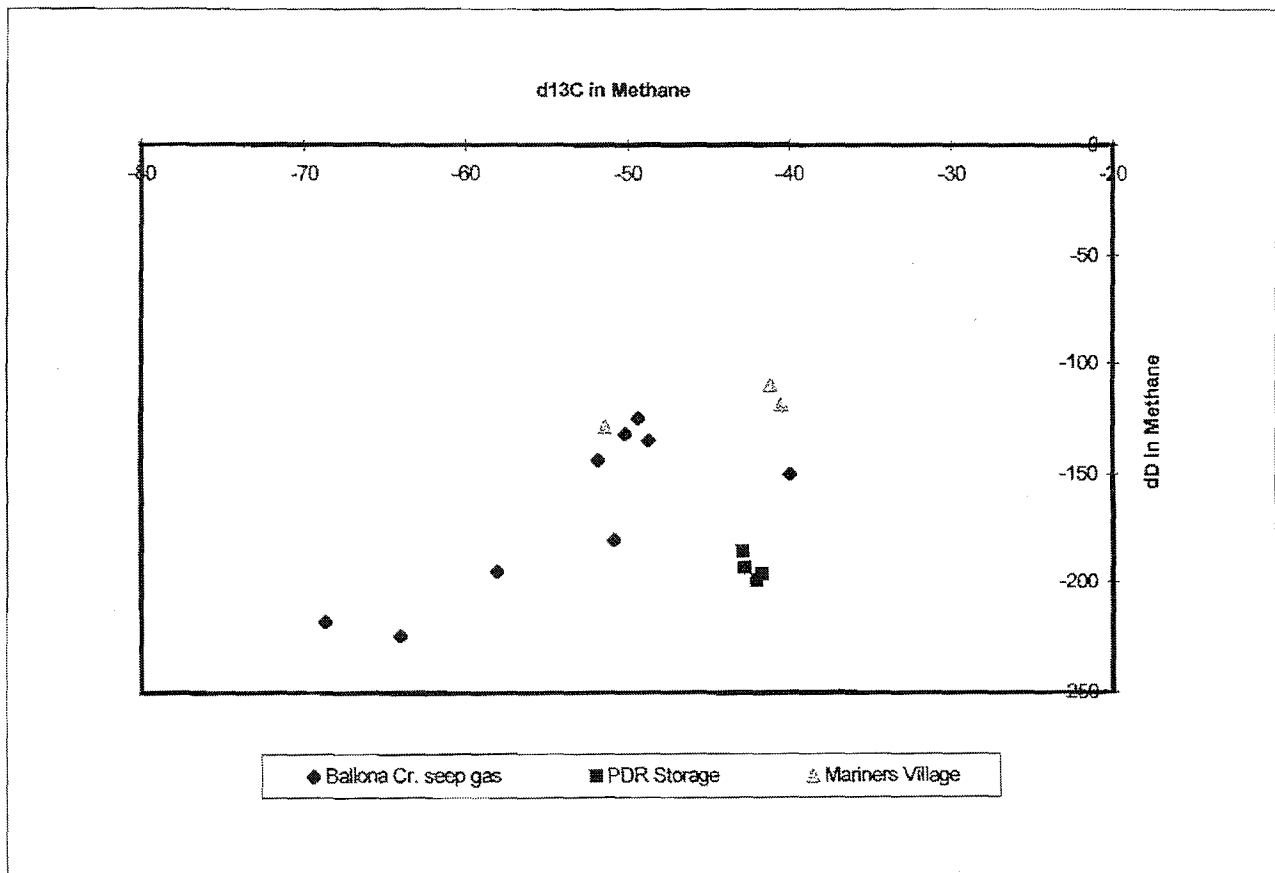

**Figure 1 Carbon Isotope Ratio vs. Deuterium Ratio in Methane  
Marina Del Rey and Playa Del Rey**

| Date   | Sample location and depth: | d13C in methane | Ballona Cr. seep gas | PDR Storage | Mariners Village | Who Collected       |
|--------|----------------------------|-----------------|----------------------|-------------|------------------|---------------------|
| Nov-93 | Centinela Cr Ave.          | -50.875         | -180                 |             |                  | Global Geochemistry |
| Nov-93 | PDR Line 1159              | -42.92          |                      | -185.5      |                  | Global Geochemistry |
| Apr-96 | PDR Line 1167              | -42.0           |                      | -199        |                  | So Cal Gas          |
| Feb-98 | Playa Vista: SG 1-3'       | -51.86          | -144                 |             |                  | CDM                 |
| Feb-98 | Playa Vista: SG 2-5'       | -49.41          | -125                 |             |                  | CDM                 |
| Feb-98 | Playa Vista: SG 2-9'       | -50.17          | -132                 |             |                  | CDM                 |
| Feb-98 | PV: SG 2-9':Ground water   | -48.72          | -135                 |             |                  | CDM                 |
| Feb-98 | Playa Vista: SG 3-3'       | -58.09          | -195                 |             |                  | CDM                 |
| Feb-98 | Playa Vista: SG 4-0'       | -39.95          | -150                 |             |                  | CDM                 |
| Sep-00 | Mariners Village V 3-15'   | -51.44          |                      |             | -129             | Sierra Labs         |
| Sep-00 | Mariners Village V 3-8'    | -41.16          |                      |             | -110             | Sierra Labs         |
| Oct-00 | seep at Block 11           | -64.00          | -224                 |             |                  | So Cal Gas          |
| Oct-00 | Fast 1                     | -42.78          |                      | -193        |                  | So Cal Gas          |
| Oct-00 | SCP 1                      | -41.72          |                      | -196        |                  | So Cal Gas          |
| Apr-01 | DR 18 sfc csg              | -68.65          | -218                 |             |                  | So Cal Gas          |
| Apr-01 | Mariners Village V 3-0'    | -40.52          |                      |             | -119             | Komex               |

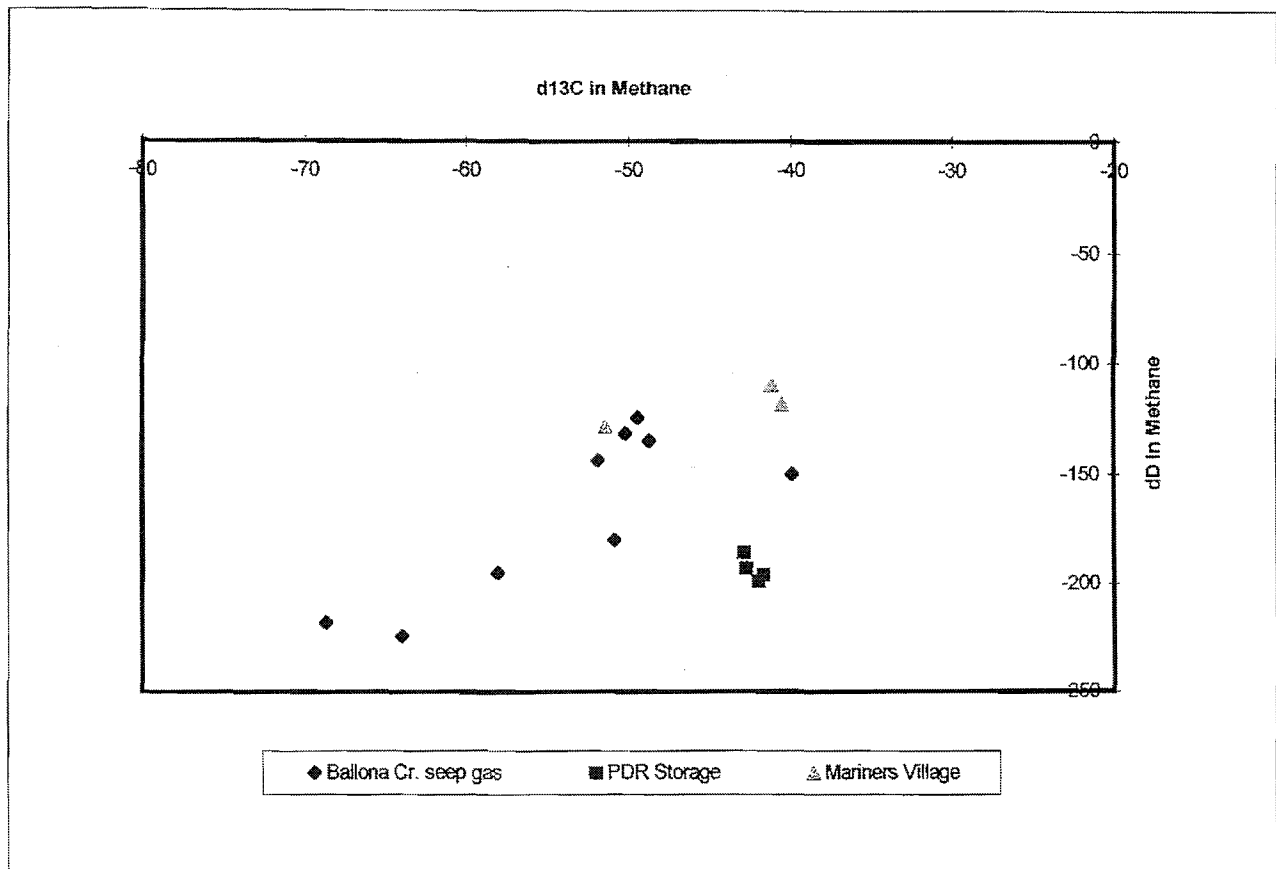

Table 1

## Marina Del Rey Soil Gas and Playa Del Rey Storage Gas Analyses

| Sample location:                        | V 3                                               | Del Rey 18                    | SCP 1              | Del Rey 15 &<br>Del Rey 18    | Vidor 17                                                   | Vidor 12            | Vidor 9            | Line 1159            |
|-----------------------------------------|---------------------------------------------------|-------------------------------|--------------------|-------------------------------|------------------------------------------------------------|---------------------|--------------------|----------------------|
| Zone:                                   | Barhole in<br>Mariner's<br>Village<br>Surface Gas | Gas from<br>Surface<br>Casing | Storage<br>Shut-in | Storage: "Del<br>Rey Gas Cap" | Storage, flowing<br>(providing lift gas<br>for DR 15 & 18) | Storage,<br>flowing | Storage<br>Shut-in | "Del Rey Gas<br>Cap" |
| Date Sampled:                           | 4/18/01                                           | 4/17/01                       | 10/16/00           | 2/2/98                        | 2/2/98                                                     | 3/13/98             | 3/13/98            | 11/15/93             |
| <b>Hydrocarbon Analysis (in mole %)</b> |                                                   |                               |                    |                               |                                                            |                     |                    |                      |
| Oxygen                                  | air total:                                        | 0.285                         | 0.089              | 0.083                         | 0.055                                                      | 0.000               | 0.367              | 0.64                 |
| Nitrogen                                | 94.947                                            | 1.715                         | 2.634              | 0.720                         | 0.787                                                      | 0.776               | 2.065              | 0.42                 |
| Carbon Dioxide                          | 2.247                                             | 0.062                         | 1.003              | 1.243                         | 1.219                                                      | 1.227               | 1.226              | 0.98                 |
| Methane                                 | 2.806                                             | 97.894                        | 90.561             | 94.105                        | 94.675                                                     | 94.216              | 92.083             | 94.80                |
| Ethane                                  |                                                   |                               | 3.901              | 3.302                         | 2.652                                                      | 2.932               | 3.340              | 3.03                 |
| Propane                                 |                                                   |                               | 1.001              | 0.571                         | 0.435                                                      | 0.591               | 0.660              | 0.68                 |
| iso-Butane                              |                                                   |                               | 0.299              | 0.0600                        | 0.0640                                                     | 0.0701              | 0.0761             | 0.069                |
| n-Butane                                |                                                   |                               | 0.289              | 0.0850                        | 0.0640                                                     | 0.0959              | 0.0985             | 0.110                |
| iso-Pentane                             |                                                   |                               | 0.0970             | 0.0270                        | 0.0170                                                     | 0.0262              | 0.0251             | 0.032                |
| n-Pentane                               |                                                   |                               | 0.0115             | 0.0240                        | 0.0140                                                     | 0.0216              | 0.0202             | 0.028                |
| C6+ Residuals                           |                                                   |                               | 0.0975             | 0.0500                        | 0.0180                                                     | 0.0438              | 0.0038             |                      |
| % Combustibles                          | 2.806                                             | 97.894                        | 96.2570            | 98.224                        | 97.939                                                     | 97.997              | 96.307             | 98.749               |
| Carbon Isotope Ratio                    | -40.52                                            | -68.65                        | -41.72             | -42.73                        | -42.76                                                     | -42.1               | -43.1              | -42.9                |
| Deuterium Isotope Ratio                 | -119                                              | -218                          | -196               |                               |                                                            |                     |                    | -186                 |
| Isotope Ratio Lab**                     | Zymax                                             | Zymax                         | Zymax              | GGC                           | GGC                                                        | GGC, GS             | GS                 | GGC                  |
| Helium (in ppm)                         | 9                                                 | ND < 7                        | 117                | 144                           | 135                                                        | 140                 | 150                | 230                  |

Background helium concentrations at the EAC:

Average of 8 tests performed on 4/23/01 and

13 ppm

May 3, 2001

## Isotope ratio data for samples submitted by Southern California Gas Company

| Zymax ID | Sample ID | Methane                         | Methane                    |
|----------|-----------|---------------------------------|----------------------------|
|          |           | $\delta^{13}\text{C}(\text{‰})$ | $\delta\text{D}(\text{‰})$ |
| 23609-1  | V3        | -40.52                          | -112                       |
| STANDARD |           |                                 |                            |
| NBS      |           | -29.82                          | -119                       |
| NBS-DUP  |           | -29.78                          |                            |

23609.wpd h117con115a

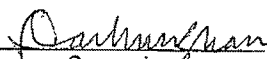
  
Supervisor

September 29, 2000

Isotope ratio data for samples submitted by Komex H2O Science, Inc.

| Zymax ID | Sample ID | Methane                   |                      |
|----------|-----------|---------------------------|----------------------|
|          |           | $\delta^{13}\text{C}$ (‰) | $\delta\text{D}$ (‰) |
| 21356-1  | 3-8'      | -41.16                    | -110                 |
| 21356-2  | 3-15'     | -51.44                    | -129                 |
| STANDARD |           |                           |                      |
| NBS      |           | -29.81                    | -119                 |
| NBS-DUP  |           | -29.79                    |                      |

21356 wpd con273

*D. Kushnaw*  
Supervisor

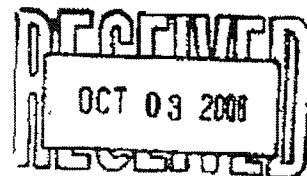

P.2/5

RFR 06 '01 12:58PM KOMEX H2O SCIENCE

September 27, 2000

Date received: 9-23-2000  
Date analyzed: 9-26-2000

Hydrocarbon concentrations in samples submitted by Komex H2O Science Inc.

| Sample ID        | Zymax ID | C1    | C2* | C2 | C3  | i-C4 | n-C4 | i-C5 | n-C5 |
|------------------|----------|-------|-----|----|-----|------|------|------|------|
|                  |          | ppmv  |     |    |     |      |      |      |      |
| 3-8'             | 21356-1  | 21600 | <10 | 14 | <10 | <10  | <10  | <10  | <10  |
| 3-15'            | 21356-2  | 21000 | <10 | 14 | <10 | <10  | <10  | <10  | <10  |
| Detection Limit: |          | 10    | 10  | 10 | 10  | 10   | 10   | 10   | 10   |

QA/QC data for C<sub>1</sub>-C<sub>5</sub> analysis

| Analytes | RF x 10 <sup>5</sup> | RF <sub>0</sub> x 10 <sup>5</sup> | % D  | Acceptance Limit % |
|----------|----------------------|-----------------------------------|------|--------------------|
| C1       | 0.196                | 0.188                             | -4.1 | ± 10               |
| C2 / C2* | 0.381                | 0.371                             | -2.6 | ± 10               |
| C3       | 0.620                | 0.576                             | -7.1 | ± 10               |
| iC4      | 0.850                | 0.830                             | -2.4 | ± 10               |
| nC4      | 0.900                | 0.900                             | 0.0  | ± 10               |
| iC5      | 1.33                 | 1.34                              | 0.8  | ± 10               |
| nC5      | 1.35                 | 1.46                              | 8.1  | ± 10               |

RF = Mean response factor from 3 point calibration  
RF<sub>0</sub> = Daily calibration standard response factor  
% D = % Difference  
Calibration file: c1c5m0174.cal

21056c1c5.wpd

*Dariusz Nowak*  
Supervisor



SIERRA LABORATORIES  
TEL: 714-348-9389  
FAX: 714-348-9115  
26052 Merit Circle • Suite 105 • Laguna Hills, CA • 92653

# CHAIN OF CUSTODY RECORD

Date: 9/22/00 Page 1 of 1

Lab Project No.:

Client: Komex H2O Science Inc  
Client Address: 5500 Bolsa Ave Suite 105  
Huntington Beach CA 92649  
Client Tel. No: 714 379 1157  
Client Fax No: 714 379 1160  
Client Proj. Mgr.: James Farrow

Turn Around Time Requested:  
 Immediate Attention  
 Rush 24-Hr Service  
 Rush 48-Hr Service  
 Standard  
 Other

### Analyses Requested

| Method Name (CEN or CALIBS LPT) | Method Name (CEN or CALIBS LPT) | Method Name (CEN or CALIBS LPT) | Method Name (CEN or CALIBS LPT) | Method Name (CEN or CALIBS LPT) | Method Name (CEN or CALIBS LPT) | Method Name (CEN or CALIBS LPT) | Method Name (CEN or CALIBS LPT) | Method Name (CEN or CALIBS LPT) |
|---------------------------------|---------------------------------|---------------------------------|---------------------------------|---------------------------------|---------------------------------|---------------------------------|---------------------------------|---------------------------------|
|                                 |                                 |                                 |                                 |                                 |                                 |                                 |                                 |                                 |
|                                 |                                 |                                 |                                 |                                 |                                 |                                 |                                 |                                 |
|                                 |                                 |                                 |                                 |                                 |                                 |                                 |                                 |                                 |
|                                 |                                 |                                 |                                 |                                 |                                 |                                 |                                 |                                 |
|                                 |                                 |                                 |                                 |                                 |                                 |                                 |                                 |                                 |
|                                 |                                 |                                 |                                 |                                 |                                 |                                 |                                 |                                 |

| Client Sample No. | Sierra Sample No. | Date/Time       | Matrix | Preservatives | Container Type | No. of Containers |
|-------------------|-------------------|-----------------|--------|---------------|----------------|-------------------|
| 3-8'              |                   | 9/22/00<br>0950 | Gas    |               | 1/2 Tedlar     | 1                 |
| 3-15'             |                   | 9/22/00<br>1010 | Gas    |               | 1/2 Tedlar     | 1                 |
|                   |                   |                 |        |               |                |                   |
|                   |                   |                 |        |               |                |                   |
|                   |                   |                 |        |               |                |                   |
|                   |                   |                 |        |               |                |                   |
|                   |                   |                 |        |               |                |                   |

Comments

Sample Submitted By: Andie Zawadzki  
Printed Name: Andie Zawadzki  
Relinquished By: Andie Zawadzki  
Company: Komex

Received By: H. [Signature]  
Company: CAL. OVERSIGHT

Total Number of Containers Submitted to Laboratory

Total Number of Containers Received by Laboratory

FOR LABORATORY USE ONLY - Sample Receipt Conditions:  
 Inlet  Cooled - Temp (°C)

Sample Disposal:

Return to Client

Lab Storage

Archive \_\_\_\_\_

Other \_\_\_\_\_

APR 06 '01 12:06PM KOMEX H2O SCIENCE



INTEROFFICE



CORRESPONDENCE

12:08 AM

Mr. P. S. Magruder, Jr.

FROM

B. F. Jones

DATE

August 7, 1975

SUBJECT: Playa del Rey - Gas Migration

Action Plan:

Try and pinpoint the source of migrated Playa del Rey stored gas by running sound logs on 14 wells which have temperature anomalies, of 3° or more from the normal gradient. Radioactive tracer surveys will be run on wells which show high frequency sound anomalies. The estimated cost of this program is \$40,000. In accordance with our discussion, we will accumulate these costs under a miscellaneous work order. We will try and start sound survey work during the week of August 18, 1975. I told Mr. John Brady of our plans this afternoon, and he said we should proceed with the work.

Discussion

HELIUM PRESENT IN SURFACE CASING

The following summarizes discussions that Jack Hampton, Jeevan Anand and I had July 31, 1975 relating to the Playa del Rey gas migration problem. This discussion resulted in the above plan of action. As you know, we have some very small volumes of stored gas coming to the surface around the cellar of Del Rey 17. We have also had reports this year of gas containing helium present in the surface casing annulus of 26 wells. This information was summarized by John Melton in his letter to me dated February 26, 1975 (attached). A re-survey of surface casing annular gas in May 1975 found gas with traces of helium present in 16 wells. Within the last year, temperature surveys have been made on 53 of the 69 wells. Forty-one of these surveys were made in 1975. Twelve surveys are scheduled to complete this program. Sixteen wells had temperature anomaly varying 3° or more from the normal gradient. A total of six sound logs have been run within the last two years. Three of them were run this year. The only sound log that show a definite hole in the casing was that made on the well Playa del Rey 12-1. Sound logs run in Del Rey 17 and 18 indicated shallow (above 1000') low-cut noises. This is interpreted to represent gas movement outside of the casing. A temperature survey made on Del Rey 18 in June of this year is significantly different than the survey ran in September 1974, suggesting that the well may now be leaking.

The Del Rey wells can generally be grouped as either wells in the flat area or wells in the bluff area. Wells in the flat area are very close to sea level and all except the top 8-10 feet of the casing should be covered by ground water. Wells in the bluff area are those wells where the wellhead is at least 8-10 feet up to 150 feet above sea level. All wells are subject to tidal fluctuation which would

August 7, 1975

possibly cause a wetting and drying of the casing near sea level. Four wells in the bluff area have developed shallow casing leaks, three of the leaks were near sea level, and probably due to casing corrosion. The first of these three was Big Ben #1 which was repaired in 1964. The second was 12-1 which occurred in August 14, 1974 and the third was 24-2 which occurred April 30, 1975.

The area where storage gas is currently surfacing is in the flat area. Sound logs suggest gas movement from a depth of about 1000' below sea level. The temperature anomaly in Del Rey 18 is approximately 1100' below sea level. It seems reasonable to re-survey this well using a sound log as soon as possible. Next, it would seem prudent to survey with a sound log all wells with a temperature deviation of 3° or more from gradient. Any well which shows a high frequency sound anomaly should have the potential leak evaluated using a radioactive tracer survey.

Cost of running at least 14 sound logs is estimated to be \$2,000 per well or \$28,000 for the sound log program. If sound anomalies were found on five wells, an additional \$10,000 should be allowed for radioactive tracer surveys. \$2,000 contingency allowance would bring the estimated total cost of this migration study up to \$40,000. It is our opinion that this study should be undertaken this year in order to evaluate the Playa del Rey gas migration problem.

**STORAGE GAS IS CURRENTLY SURFACING IN THE FLAT AREA**

BFJ:eo  
Attachment

- cc: Messrs. J. P. Anand
- H. C. Carson
- J. D. Hampton
- A. S. Olson
- D. Wood

**GAS MOVEMENT IS FROM 1000 FEET**

also filed in Playa del Rey Misc. Correspondence

**• DEL REY 18 IS FROM APPROXIMATELY 1100' (BASED ON TEMPERATURE ANOMALY)**

WUES. 11/10/13, WWS, VC-STAFF (1 OF 5)  
1975 VINTAGE

NOTE: DEL REY 17  
(REPORTING LEAKS TO THE  
SURFACE IS LOCATED  
AT FAULT PLANE

NORTH OF BALLONA CREEK  
FAULT (?)

LEAKING  
STORAGE GAS  
TO THE SURFACE

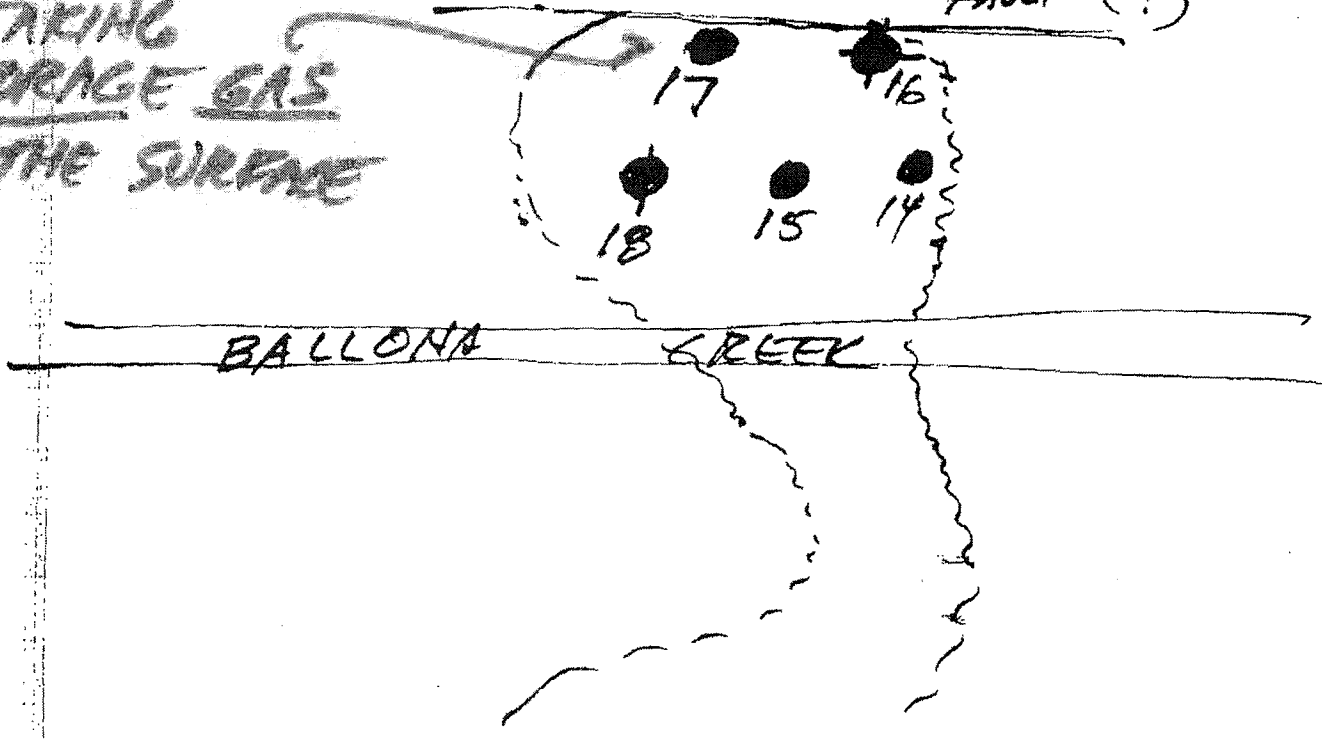

AGENDA FOR ANNUAL REVIEW MEETING WITH  
DIVISION OF OIL AND GAS FOR PLAYA DEL REY,  
MONTEBELLO AND EAST WHITTIER FIELDS  
June 7, 1983

Attending:

E. Brannon, Division of Oil and Gas  
C. M. Goldwasser  
J. W. Gourley  
D. Lande, Division of Oil and Gas  
L. L. Langer  
P. S. Magruder, Jr.  
K. M. Taira  
R. E. Wallace

Playa del Rey

Project Performance - No unusual or unpredicted occurrences. Maximum injection pressures range from 1400 psi to 1700 psi wellhead. Discovery pressure was 2750 psi bottomhole. Plot of annual rate of oil produced vs. cumulative oil attached. Explanation of basic usage of reservoir provided by Mr. Goldwasser.

Conservation - No losses detected. Documentation of monitoring system presented by Mr. Goldwasser.

Pollution Prevention - Status of subsurface safety valve installations: 1. All wells but So. Cal. 1 will be completed this year. 2. Discussion of "Conditions for Operating Critical Wells Without Subsurface Safety Valves" with regard to extension granted for So. Cal 1 - Mr. Gourley. Presentation on Testing of Safety Systems, Water Disposal, and Spill Prevention - Mr. Goldwasser.

Operations - One leak found and repaired at Del Rey 18 and two subsurface safety valves failed at 24-2 and 27-1 and have been replaced. Del Rey 18 was typical of shoe leaks at Playa del Rey in that the storage zone was being dump flooded from above in this well. A W.S.O. was reestablished on the production casing shoe.

Geology and Engineering - Reservoir simulation study in progress. One of new wells to be drilled this year will be cored.

East Whittier

Project Performance - No unusual or unpredicted occurrences. Presentation on normal and summer usage of field by Mr. Wallace.

Conservation - No losses detected. Monitoring program is similar to that used at Playa del Rey and Montebello.

Pollution Prevention - All critical wells protected. No oil production. No waste water disposal problems.

Operations - None for past year.

Geology and Engineering - Discussions under way with Chevron for return of migrating gas.

Montebello

Project Performance - Incidents at Burke Community 3 and Braun 7 will be discussed under Operations. No other unusual or unpredicted occurrences. Plot of annual rate of oil produced vs. cumulative oil attached. Explanation of basic usage of reservoir provided by Mr. Wallace.

Conservation - Documentation of monitoring system presented by Ms. Langer and Mr. Wallace. It is expected that a few wells will require work following this past withdrawal season and every effort is being made for early detection and resolution of these problems.

Pollution Prevention - Status of safety valve installations: All critical wells will be equipped by November of 1985 as per previous correspondence.

Presentation of water disposal and spill prevention methods by Mr. Wallace.

Operations - Two wells converted to cased hole observation wells, Dore 2 and Braun 7 (in progress)

One subsurface safety valve installed (MGS 22-1) and two repaired (Cole 1 and Long 1). *valve*

*control line*

One innerstring run to secure casing repair at MGS 2-10. Four Big Tubing Safety Valve installations (MGS 15-28 and Howard & Smith 5, 9, & 10).

Brief description of incident at Burke Community 3 by Mr. Taira.

Geology and Engineering - Nothing new to report.

LLL:pr

WELL  
TEST

PRESSURE BUILD-UP  
IN THE SURFACE  
CASING PROVES  
THAT 100% OF  
THE WELLS ARE  
LEAKING GAS TO  
THE SURFACE IN  
THE ANNULUS BETWEEN  
THE CASING AND THE  
BAR HOLE

(FR) 1/10/1, 1003 1:10 PM  
1:20 PM  
VIDOR 9

# BARHOLE GAS CONFIRMATION

BARHOLE (BH) IN FRONT OF RAMP

REPORT DATE: 3/11/98

MOLE %

|             |         |
|-------------|---------|
| METHANE     | 20.8830 |
| ETHANE      | .5850   |
| PROPANE     | .1190   |
| ISO-BUTANE  | .01159  |
| N-BUTANE    | .01418  |
| ISO-PENTANE | .00462  |
| N-PENTANE   | .0000   |
| C6 PLUS     | .00334  |

HELIUM

160 PPM

## ENGINEERING ANALYSIS CENTER

BTU Content of Natural Gas by Gas Composition  
(Southern California Gas Company)

PROJECT NO: \_\_\_\_\_  
 REPORTED BY: D.S. Tomlinson  
 REPORT DATE: 3/11/98  
 TEST LOCATION: Vidor 9, BH in front of ramp  
 SAMPLE DATE: 3/9/98

| Component      | Mole %<br>Xi | (1)<br>HHV | (2)<br>LHV | (3)<br>SG | Xi*HHV<br>Btu/SCF | Xi*LHV<br>Btu/SCF | Xi*SG  |
|----------------|--------------|------------|------------|-----------|-------------------|-------------------|--------|
| METHANE        | 20.88300     | 1012.3     | 911.5      | 0.5539    | 211.4             | 190.3             | 0.1157 |
| ETHANE         | 0.58500      | 1773.7     | 1622.4     | 1.0382    | 10.4              | 9.5               | 0.0061 |
| PROPANE        | 0.11900      | 2521.9     | 2320.3     | 1.5226    | 3.0               | 2.8               | 0.0018 |
| iso-BUTANE     | 0.01159      | 3259.4     | 3007.3     | 2.0068    | 0.4               | 0.3               | 0.0002 |
| n-BUTANE       | 0.01418      | 3269.8     | 3017.8     | 2.0068    | 0.5               | 0.4               | 0.0003 |
| iso-PENTANE    | 0.00462      | 4010.2     | 3707.6     | 2.4910    | 0.2               | 0.2               | 0.0001 |
| n-PENTANE      | 0.00000      | 4018.2     | 3715.5     | 2.4910    | 0.0               | 0.0               | 0.0000 |
| C6 plus        | 0.00334      | 5194.5     | 4421.3     | 3.2522    | 0.2               | 0.1               | 0.0001 |
| CARBON DIOXIDE | 0.55600      | 0.0        | 0          | 1.5196    | 0.0               | 0.0               | 0.0084 |
| OXYGEN         | 16.12900     | 0.0        | 0          | 1.1048    | 0.0               | 0.0               | 0.1782 |
| NITROGEN       | 61.69500     | 0.0        | 0          | 0.9672    | 0.0               | 0.0               | 0.5967 |
| Totals ---->   | 100.00       |            |            |           | 226.0             | 203.7             | 0.9076 |

(4) Compressibility Factor (Z) for mixed gases

|                           |         |                |
|---------------------------|---------|----------------|
| Total Non-Hydrocarbons    | 78.4    | Helium 160 ppm |
| A = (Total SG)(0.0101)    | 0.00917 |                |
| B = (Total Non-HC)(.0070) | 0.00549 |                |
| Z = 1.00369 - A + B       | 1.00001 |                |

(5) Adjusted Values (14.73 psia, 60F, Gross, Dry, real volume basis)

|                  |                           |
|------------------|---------------------------|
| HHV              | 226.0 BTU/real cubic foot |
| LHV              | 203.7 BTU/real cubic foot |
| Specific Gravity | 0.9076                    |

FOOTNOTES

- (1) Higher Heating Value per ideal cubic foot @ 14.73 psia  
Gas Processors Association (GPA) Standard 2145-94
- (2) Lower Heating Value per ideal cubic foot @ 14.73 psia  
Gas Processors Suppliers Association (GPSA) Vol. II - Sec. 23 - Fig.23-2 (1987)
- (3) Specific Gravity  
Gas Processors Association (GPA) Standard 2145-94
- (4) Empirical formula for compressibility factor  
American Gas Association's Transmission Report No. 5.
- (5) Values are adjusted to reflect real volumes rather than ideal volumes by dividing by the compressibility factor.  
ex: (BTU/Ideal Gas Volume)/Z where Z=(Real Gas Volume/Ideal Gas Volume)



# ENGINEERING ANALYSIS CENTER REPORT

Project No: TS95-C105-21  
 Reported By: Fred A. Contreras  
 Report Date: 10/18/95

Request: Monthly Helium Analyses for Wells and Barholes at Playa del Rey.

Requested By: Steve Cardiff Mail Location: 9580  
 Division/Dept. Southern Region /Transmission Request Date: 10/18/95

| WELL          | TYPE | HELIUM CONTENT |         | REMARKS |
|---------------|------|----------------|---------|---------|
|               |      | ppm            | * Gas % |         |
| So. Cal # 2   |      | 78             | 40      |         |
| So. Cal # 4   |      | 57             | 39      |         |
| Trap 133      |      | 174            | 70      |         |
| Dunlap        |      | 119            | 60      |         |
| Fast          |      | 24             | 60      |         |
| Harlan        |      | 43             | 60      |         |
| DR10 - Casing |      | <7             | 25      |         |
| DR10 - BH #1  |      | <7             | 8       |         |
| DR10 - BH # 2 |      | <7             | 15      |         |
| DR10 - BH # 3 |      | 124            | 18      |         |
| Vidor 18      |      | 12             | 76      |         |
|               |      |                |         |         |
|               |      |                |         |         |
|               |      |                |         |         |

\* (ppm values adjusted to 100% combustibles except where total combustibles are less than 8.0%)

Analyzed By: Fred A. Contreras

Approved By: 

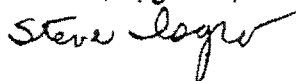
cc: PDR Field Engineer, ML 22GO  

**ENGINEERING ANALYSIS CENTER REPORT**

Project No: RC038.04  
 Reported By: L.S.Brewer  
 Report Date: 8/4/98

**Request: Monthly helium analysis for wells and barholes at Playa del Rey**

Requested By: Eugene Covington Mail Location: 9580  
 Division/Dept. So. Region / Trans. Request Date: 8/3/98

| WELL     | TYPE   | HELIUM *<br>ppm | COMBUSTIBLE GAS<br>% | REMARKS |
|----------|--------|-----------------|----------------------|---------|
| So Cal 4 | casing | 39              | 93                   |         |
| So Cal 2 | casing | ND<7            | 84                   |         |
|          |        |                 |                      |         |
|          |        |                 |                      |         |
|          |        |                 |                      |         |
|          |        |                 |                      |         |
|          |        |                 |                      |         |
|          |        |                 |                      |         |
|          |        |                 |                      |         |
|          |        |                 |                      |         |
|          |        |                 |                      |         |
|          |        |                 |                      |         |
|          |        |                 |                      |         |
|          |        |                 |                      |         |
|          |        |                 |                      |         |
|          |        |                 |                      |         |
|          |        |                 |                      |         |
|          |        |                 |                      |         |

\* (helium ppm values adjusted to 100% combustibles except where total combustibles are less than 8.0%)

Analyzed By: L. Brewer, M.J. Mayeda Date Sampled: 8/3/98  
 Date Analyzed: 8/3 to 8/4/98  
 Approved By: \_\_\_\_\_

cc: Leigh Brewer

FUN 1516

TEST & DEVELOPMENT CENTER REPORT

Project No: CR-237

Reported By: JOHNNY LOZANO  
Report Date: SEPT. 12, 1990

Request: Monthly Helium Analyses for (7) Pumping Unit Wells at Playa del Rey  
ANALYSES FROM (3) ADDITIONAL WELLS INCLUDED, AS PER REQUEST.

Requested By: J.A. Thompson Mail Location: 9580 Request Date: 08/17/90

Division/  
Work Group: South Basin Transmission-Underground Storage

TEST RESULTS ON SAMPLES TAKEN SEPT 11, 1990

| WELL        | HELIUM CONTENT OF CASING GAS, PPM | COMMENTS         |
|-------------|-----------------------------------|------------------|
| TROXEL 1    | 16                                | WELL NOT PUMPING |
| TOWNSITE 2  | 34                                | WELL PUMPING     |
| TOWNSITE 3  | 38                                | WELL NOT PUMPING |
| TOWNSITE 11 | 65                                | WELL PUMPING     |
| BLOCK 10R   | 31                                | WELL NOT PUMPING |
| BLOCK 11    | 71                                | WELL PUMPING     |
| VIDOR 18    | 10                                | WELL PUMPING     |
| SO CAL 2    | 54                                | WELL PUMPING     |
| SO CAL 4    | 48                                | WELL NOT PUMPING |
| DUNLAP 1    | 423                               | WELL PUMPING     |

Tested By: JOHNNY LOZANO

cc: R.A. Skultety, ML 401R

Approved By: [Signature] 9/12/90

TEST & DEVELOPMENT CENTER REPORT

Project No: CR-140

Reported By: L. K. McCormack  
Report Date: 5/29/90

Request: Analyze cylinder sample sent in for helium content.

Requested By: J. Thompson Mail Location: 9580 Request Date: 05/23/90

Division/  
Work Group: South Basin/Underground Storage

On 5/23/90, the Test Center received a gas sample from Playa del Rey in a stainless cylinder labeled "TroxeL Casing." The sample was analyzed for helium content using an in-lab Shimadzu chromatograph. The sample had a helium content of 22 ppm.

Tested By: L. K. McCormack

cc:

Approved By: [Signature]

September 4, 2003

TO: THE CALIFORNIA DEPARTMENT OF FISH & GAME-  
Mr. Raisbrook, Regional Manager  
San Diego, California fx 858 467 4201

FROM: GRASSROOTS COALITION-  
Patricia McPherson  
3749 Greenwood Ave.  
LA CA 90066 310 397 5779

**RE: ECOLOGICAL ASSESSMENT OF AREAS B AND D- PLAYA VISTA, 6775  
CENTINELA AVENUE, LOS ANGELES, CALIFORNIA &**

**PHASE 2 EIR- PLAYA VISTA**

Dear Mr. Raisbrook,

**Grassroots Coalition respectfully requests that the California Department of Fish & Game clarify, in writing, its scope of review and involvement regarding the Playa Vista site.**

The EIR for the Playa Vista Phase 2 is now available for review, as I am sure that you are aware. Also, the Los Angeles Regional Water Quality Control Board (LARWQCB) sent Grassroots an Ecological Assessment (EA) of Areas B and D of the Playa Vista site for review. The deadline for comments was mid-August. I have included the LARWQCB letter with its cc list. Grassroots did respond but also notified various Fish & Game personnel, including Brad Henderson- our local CA. Dept. of Fish & Game (DFG) biologist, of the EA. In my comments to the LARWQCB, I noted that DFG had not been given the EA. Apparently, the LARWQCB has now sent the EA to DFG and given the DFG a September 15, 2003 deadline (attached letter).

While Grassroots would appreciate comments from the DFG regarding the EIR and the EA, we believe it is vitally and fundamentally important to clarify, in writing, the DFG role and scope of review at the Playa Vista site. In particular, our concern is that the oilfield gas issues at Playa Vista have not been assessed by any independent state agency.

**It is vitally important for the DFG to clarify that it has played no role in the oversight for and/or evaluation of the newly discovered oilfield gas contamination problems of the Playa Vista site as they relate to the biology and ecosystems of the area and/or any other capacity.**

The California Environmental Protection Agency- Department of Toxic Substances Control (DTSC) did respond, in writing, to the LARWQCB regarding the City of Los

Angeles' / Playa Capital gas study(May 2001), wherein DTSC stated the City study was incomplete and that:

-soil gas studies needed to be performed in native, undisturbed soils (studies performed thus far were done in soils that were predominantly disturbed from construction activities and had other problems noted by DTSC) and that,

- an ecological risk assessment needed to be performed (LARWQCB does not perform ecological risk assessments);

the DTSC sister agency, the LARWQCB, has not requested or required Playa Capital to fulfill the DTSC recommendations.

Because the oilfield gases, including benzene, toluene and xylene (BTEX) and oilfield generated hydrogen sulfide (H2S) are not issues within the scope of review for the LARWQCB, and because the LARWQCB has not adhered to the DTSC recommendations, or requested DTSC to step in for oversight of the oilfield issues (of CAL EPA agencies, DTSC has oilfield toxics within their scope of review and expertise) , there continues to be no independent state oversight for evaluations of the oilfield issues.

## **DFG HISTORY**

I have requested of the DFG, through numerous DFG personnel, including those in OSPR, of any ability of the DFG to engage in a biological study of the potential negative consequences of the oilfield operation gas migration hazards that we now know exist at the Ballona Wetlands, the site of Playa Vista. Furthermore, the impacts of the construction activities creating enhanced gas migration and H2S production are also issues that potentially affect the ecosystems of Ballona. Thus far, there has been no response from the DFG that it has the ability to engage in any way regarding any of these matters.

In conclusion, if the DFG does not clarify the fact that it has played no role in the oilfield gas issues and apparently cannot engage these issues under its scope of review and study, then any action and/or response the DFG does engage in at the Playa Vista site will leave and, has left a biological gap of oversight that needs to be clarified. **It would be entirely misleading to the public** if the DFG were to continue involvement at the Playa Vista site and not clarify exactly what it does and does not include within its scope of review, with regard to its conclusions and/or recommendations regarding the Playa Vista site.

**Mr. Raisbrook, Grassroots Coalition respectfully requests a written clarification of the DFGs role in oversight of the newly discovered oilfield gases that are migrating to the surface at Playa Vista.**

I'm sending along a Public Record Act request for your help in our providing a formal request for the information requested above and also because of our need for a copy of the Habitat Mitigation and Monitoring Plan (HMMP) for Playa Vista.

Sincerely,

Grassroots Coalition, Patricia McPherson (ccDTSC, USEPA)

**September 4, 2003**

**TO: CALIFORNIA DEPT. OF FISH & GAME,**  
Mr. Raisbrook, Regional Manager  
San Diego, CA fx 858 467 4299

**FROM: GRASSROOTS COALITION,**  
Patricia McPherson  
3749 Greenwood Ave. LA CA 90066  
310 397 5779

**RE: PUBLIC RECORD REQUEST ACT request**

Dear Mr. Raisbrook,

This is a request for records pursuant to the provisions of the California Public Records Act as amended (Cal. Gov. Code /6250, et seq.). I request an opportunity to inspect and make copies of all records prepared, owned, used, or retained by the Ca. Dept. of Fish & Game (DFG) regarding DFG participation in, oversight of the oilfield gas issues, subsidence issues of the Playa Vista site in Los Angeles, Ca. (Playa Vista site address is generally referred to as 6775 Centinela Ave. LA CA.; the site lies on both sides of the cross-roads of Jefferson Blvd. And Lincoln Blvd. In Los Angeles and is the historic site of the Ballona Wetlands)

**Please also, provide a copy of the Habitat Mitigation and Monitoring Plan (HMMP) for the Playa Vista site.**

This request includes all records regardless of form, including but not limited to letters, memoranda, telephone log entries, visitor log entries, message receipts, notations of conversations, meeting notes, e-mail messages or other records on magnetic media, fax cover sheets, reports, statistics, calendar entries, permits, questionnaires, photographs, audio tape, film, and videotape.

This request reasonably describes identifiable records or information produced therefrom and I believe no express provision of law exists exempting the requested records from disclosure. Should your agency find any portion of any requested record exempt from release, I ask that you carefully consider the public interest served by the full disclosure of all requested records.

The requested records relate to an important issue in which the public has expressed an enormous amount of interest. The Playa Vista development is located in an area of large volumes and pressures of oilfield operations gas that is migrating to the surface (Exploration Technologies Report April 2000). The public interest in these records clearly outweighs all other interests. Therefore, I request that you release non-segrated

copies of each of the requested records otherwise exempt under California Government Code 6254(a).

Should you find any portion of any requested record exempt from release, I ask that you exercise your discretionary authority to release the requested record in its entirety. If you decide against exercising your authority to release non-segregated copies of all requested records, Government Code Section 6257 requires that you release all reasonably segregable portions of the requested records. I reserve my right to challenge the withholding or deletion of any information.

If you decide to withhold any portion of any requested record, I ask that you provide me a list identifying what you have withheld. I also ask that you cite the specific exemption(s) being relied upon to withhold information. In addition, if you deny all or part of this request, Government Code Section 6256.2 requires that you provide the name and title or position of each person responsible for the denial of this request. Should you decide to withhold any information, Government Code Section 6256 requires that you notify me of the reasons for this determination no later than 10 days after receipt of this request. Government Code Section 6256.2 prohibits the use of the 10-day period, or any provisions of the Public Records Act, "to delay access for purposes of inspecting public records."

I also request any records that indicate, suggest or otherwise identify the prior existence of other records related to my request that may have been destroyed or modified. California Government Code Section 14755(a) makes clear that "(n)o record shall be destroyed or otherwise disposed of by any agency of the state" unless (1) the Director of the Department of General Services has determined that "the record has no further administrative, legal or fiscal value," and (@) "the Secretary of State has (also) determined that the record is inappropriate for preservation in the State Archives." The "willful removal" or "destruction" of agency records in violation of these statutory mandates can result in the imposition of criminal sanction. (See Cal. Gov. Code /6200( felony offense for destruction of records by "custodial officer") and Cal. Gov. Code/ 6201 (misdemeanor offense for destruction of records by "noncustodial officers")/)

Please call me at 310 397 5779 if you have any questions or need additional information. Thank you for your assistance and cooperation with this matter.

Sincerely,

Grassroots Coalition, Patricia McPherson



Case No. B213967

**COURT OF APPEAL**  
**STATE OF CALIFORNIA**  
**SECOND APPELLATE DISTRICT**  
**DIVISION THREE**

---

**ENVIRONMENTALISM THROUGH INSPIRATION AND  
NON-VIOLENT ACTION (ETINA), ET AL.**

Appellants and Petitioners

v.

**CITY OF LOS ANGELES, ET AL.**

Respondents

**PLAYA CAPITAL COMPANY LLC, ET AL.,**

Real Parties-in-Interest and Respondents

---

Los Angeles Superior Court, Case No. BS 073182  
Honorable Ann I. Jones

---

**PETITIONERS ETINA, GRASSROOTS COALITION AND DANIEL  
COHEN'S JOINT REPLY BRIEF**

---

Todd T. Cardiff, Esq. (SBN 221851)  
LAW OFFICE OF TODD T. CARDIFF  
1901 First Avenue, Suite 219  
San Diego, CA 92101  
TEL: (619) 546-5123  
FAX: (619) 546-5133

**TABLE OF CONTENTS**

**I. INTRODUCTION..... 1**

**II. LEGAL FRAMEWORK..... 2**

**III. 2007 CLA REPORT..... 4**

**A. THE 2007 CLA REPORT PROCESS WAS DESIGNED TO CREATE THE APPEARANCE OF SUBSTANTIAL EVIDENCE WHILE EXCLUDING CONTRADICTORY DATA OR OPINIONS..... 4**

**B. THE COURT IDENTIFIED THE CHANGES NECESSARY TO THE EIR AND DETERMINED THAT SUCH CHANGES COULD RESULT IN NEW SIGNIFICANT EFFECTS REQUIRING A SUPPLEMENTAL OR SUBSEQUENT EIR..... 5**

**C. THE CITY FAILED TO PROCEED IN A MANNER REQUIRED BY LAW BY FAILING TO IDENTIFY THE CHANGES NECESSARY TO CURE THE DEFECTS IN THE 1993 EIR..... 7**

**D. THERE IS NO EVIDENCE THAT THE CITY COUNCIL MEMBERS CONSIDERED THE 1993 EIR IN CONJUNCTION WITH THE 2007 CLA REPORT..... 10**

**E. THE BASELINE OF THE CDM MODEL IS NOT ACCURATE AND BASELINE CONDITIONS WERE NOT PROPERLY DETERMINED OR DISCLOSED TO THE PUBLIC..... 13**

**F. THERE IS NO EVIDENCE IN THE RECORD THAT THE CITY CONDUCTED A CUMULATIVE IMPACTS ANALYSIS OF ALL DEWATERING..... 17**

**G. THE CITY’S FAILURE TO PROVIDE THE PERTINENT DATA, MUCH LESS RAW DATA, PRECLUDED INFORMED PUBLIC PARTICIPATION**

|                                                                                                                                                                                                                                           |           |
|-------------------------------------------------------------------------------------------------------------------------------------------------------------------------------------------------------------------------------------------|-----------|
| <b>AND PREVENTED THE PUBLIC FROM VERIFYING<br/>THE ACCURACY OF THE GROUNDWATER MODEL....</b>                                                                                                                                              | <b>19</b> |
| <b>H. THE CITY NEVER DETERMINED WHETHER THE<br/>50-FOOT VENT WELLS WOULD BE EFFECTIVE FOR<br/>THE LIFE OF THE PROJECT WITHOUT<br/>DEWATERING.....</b>                                                                                     | <b>23</b> |
| <b>I. PETITIONERS EXHAUSTED THEIR<br/>ADMINISTRATIVE REMEDIES BECAUSE THE CITY<br/>FAILED TO IDENTIFY THE 2007 CLA REPORT AS AN<br/>ADDENDUM.....</b>                                                                                     | <b>25</b> |
| <b>IV. MOTION TO AUGMENT.....</b>                                                                                                                                                                                                         | <b>28</b> |
| <b>A. THIS COURT MAY CONSIDER RELEVANT AND<br/>IMPROPERLY EXCLUDED EXTRA-RECORD<br/>DOCUMENTS BECAUSE PETITIONERS HAVE<br/>PROVEN SUCH DOCUMENTS FALL UNDER THE<br/>EXCEPTION ENUNCIATED BY THE SUPREME<br/>COURT OF CALIFORNIA.....</b>  | <b>28</b> |
| <b>i. The Record of Proceedings Under Public Resources<br/>Code Section 21167.6(e) is Broad and<br/>Inclusive.....</b>                                                                                                                    | <b>29</b> |
| <b>ii. The Extra-Record Documents at Issue Here Are<br/>Relevant and Important to the Analysis of<br/>Cumulative Impacts and to Potential Worst Case<br/>Scenario Impacts.....</b>                                                        | <b>30</b> |
| <b>iii. The Extra-Record Documents at Issue Here Were<br/>in Existence Prior to the City’s Decision and Could<br/>Not be Produced at the Administrative Level in the<br/>Exercise of Reasonable Diligence.....</b>                        | <b>32</b> |
| <b>iv. The Circumstances Here Warrant Consideration<br/>of the Extra-Record Documents Because They<br/>Demonstrate Agency Misconduct and Suppression of<br/>Evidence in Violation of the Information Disclosure<br/>Requirements.....</b> | <b>34</b> |
| <b>V. REQUEST FOR RECONSIDERATION OF ETINA I.....</b>                                                                                                                                                                                     | <b>36</b> |

|                                                                                                                                                                                              |           |
|----------------------------------------------------------------------------------------------------------------------------------------------------------------------------------------------|-----------|
| <b>A. THERE IS NO WAIVER ON APPEAL BECAUSE THE TRIAL COURT DID NOT HAVE THE POWER TO REVERSE THE APPELLATE COURT.....</b>                                                                    | <b>36</b> |
| <b>B. REQUEST FOR SUPREME COURT REVIEW OR RECONSIDERATION CANNOT HAVE BEEN EXPECTED WHEN PETITIONERS APPEARED TO RECEIVE THEIR REQUESTED RELIEF IN A SUBSEQUENT OR SUPPLEMENTAL EIR.....</b> | <b>38</b> |
| <b>C. THE EXPLOSIVE NATURE OF METHANE AND IMPORTANT CEQA PRINCIPALS ARE EXCEPTIONAL CIRCUMSTANCES JUSTIFYING THE RECONSIDERATION OF ETINA I.....</b>                                         | <b>39</b> |
| <b>D. THE COURT SHOULD BE WILLING TO REVIEW THE QUESTION OF LAW STATED IN ETINA I, AND STATE THE PROPER INTERPRETATION OF CEQA GUIDELINE SECTION 15162.....</b>                              | <b>42</b> |
| <b>VI. CONCLUSION.....</b>                                                                                                                                                                   | <b>46</b> |

## TABLE OF AUTHORITIES

### Cases

|                                                                                                                                 |        |
|---------------------------------------------------------------------------------------------------------------------------------|--------|
| <i>American Canyon Community United for Responsible Growth v. City of American Canyon</i><br>(2006) 145 Cal. App. 4th 1062..... | 3,7    |
| <i>Automotive Management Group, Inc. v. New Motor Vehicle Bd.</i><br>(1993) 20 Cal. App. 4th 1002.....                          | 37     |
| <i>Benton v. Bd. Of Supervisors</i><br>(1991) 226 Cal. App. 3d 1467.....                                                        | 45     |
| <i>Blue v. City of Los Angeles</i><br>(2006) 137 Cal. App. 4th 1131.....                                                        | 21,22  |
| <i>Butler v. Superior Court</i><br>(2002) 104 Cal. App. 4th 979.....                                                            | 37     |
| <i>Cadiz Land Co. v. Rail Cycle</i><br>(2000) 83 Cal. App. 4th 74.....                                                          | 28,34  |
| <i>Citizens of Goleta Valley v. Board of Supervisors</i><br>(1990) 52 Cal. 3d 553.....                                          | 2      |
| <i>City of San Jose v. Great Oaks Water Co.</i><br>(1987) 192 Cal. App.3d 1005.....                                             | 6      |
| <i>County of Amador v. El Dorado County Water Agency</i><br>(1999) 76 Cal. App. 4th 931.....                                    | 4,5,22 |
| <i>County of Inyo v. City of L.A.</i><br>(1984) 160 Cal. App. 3d 1178.....                                                      | 4      |
| <i>County of Orange v. Superior Court</i><br>(2003) 113 Cal. App. 4th 1.....                                                    | 29     |
| <i>Defend the Bay v. City of Irvine</i><br>(2004) 119 Cal. App. 4th 1261.....                                                   | 24     |

|                                                                                                                      |          |
|----------------------------------------------------------------------------------------------------------------------|----------|
| <i>In re Marriage of Moschetta</i><br>(1994) 25 Cal. App. 4th 1218.....                                              | 36       |
| <i>Kleist v. City of Glendale</i><br>(1976) 56 Cal. App. 3d 770.....                                                 | 12       |
| <i>Laurel Heights Improvement Assn. v. Regents of University of California</i><br>(1988) 47 Cal. 3d 376.....         | 41,42    |
| <i>Long Beach Sav. &amp; Loan Ass'n v. Long Beach Redevelopment Agency</i><br>(1986) 188 Cal. App. 3d 249.....       | 45       |
| <i>McPherson v. City of Manhattan Beach</i><br>(2000) 78 Cal. App. 4th 1252.....                                     | 27       |
| <i>Nat'l Parks &amp; Conservation Ass'n v. County of Riverside</i><br>(1999) 71 Cal. App. 4th 1341.....              | 13       |
| <i>No Oil v. Los Angeles</i><br>(1974) 13 Cal. 3d 68.....                                                            | 21       |
| <i>People v. County of Kern</i><br>(1974) 39 Cal. App. 3d 830.....                                                   | 11       |
| <i>People v. Scott</i><br>(2000) 85 Cal. App. 4th 905.....                                                           | 38       |
| <i>Pocket Protectors v. City of Sacramento</i><br>(2004) 124 Cal. App. 4th 903.....                                  | 43       |
| <i>Quail Botanical Gardens Foundation, Inc. v. City of Encinitas</i><br>(1994) 29 Cal. App. 4th 1597.....            | 43       |
| <i>River Valley Preservation Project v. Metropolitan Transit Development Bd.</i><br>(1995) 37 Cal. App. 4th 154..... | 11,12,44 |
| <i>San Joaquin Raptor/Wildlife Rescue Center v. County of Stanislaus</i><br>(1994) 27 Cal. App. 4th 713.....         | 2,40     |
| <i>Santiago County Water Dist. v. County of Orange</i>                                                               |          |

|                                                                                                                        |          |
|------------------------------------------------------------------------------------------------------------------------|----------|
| (1981) 118 Cal. App. 3d 818.....                                                                                       | 2        |
| <i>Save Our Peninsula Committee v. Monterey County Bd. Of Supervisors</i><br>(2001) 87 Cal. App. 4th 99.....           | 13,14    |
| <i>Save San Francisco Bay Assn. v. San Francisco Bay Conservation<br/>etc.Com.</i><br>(1992) 10 Cal. App. 4th 908..... | 11       |
| <i>Snarled Traffic Obstructs Progress v. City &amp; County of San Francisco</i><br>(1999) 74 Cal. App. 4th 793.....    | 44,45    |
| <i>Sundstrom v. County of Mendocino</i><br>(1988) 202 Cal. App. 3d 296.....                                            | 5,34     |
| <i>Uhler v. City of Encinitas</i><br>(1991) 227 Cal. App. 3d 795.....                                                  | 43       |
| <i>Western States Petroleum Assn. v. Superior Court</i><br>(1995) 9 Cal. 4th 559.....                                  | passim   |
| <i>Woodward Park Homeowners Assn., Inc. v. City of Fresno</i><br>(2007) 150 Cal. App.4th 683.....                      | 26,36,37 |

**Statutes**

|                               |             |
|-------------------------------|-------------|
| Code Civ. Pro. § 1021.5.....  | 47          |
| Code Civ. Pro. § 1094.5.....  | 11,28,29,35 |
| Pub. Res. Code § 21003.1..... | 4,21        |
| Pub. Res. Code § 21005.....   | 4,21,35     |
| Pub. Res. Code § 21061.....   | 20,21       |
| Pub. Res. Code § 21068.....   | 6           |
| Pub. Res. Code § 21081.....   | 23          |
| Pub. Res. Code § 21082.2..... | 21          |

## I. INTRODUCTION

If the Court only had five minutes to try this case, Petitioners would urge the Court to ask one question. What is the total amount of dewatering that is occurring from all sources in the Playa Vista area? The City of Los Angeles (“City”) cannot answer that question. Real parties-in-interest could probably answer that question, but not from the information in the record. The record is silent on this vital question.

In fact, the record is silent on all rates and volumes of discharges. Yes, the record reveals an estimated groundwater discharge from five buildings of 16,000 gallons per day. But no back-up for that number. The record does not even reveal how the estimates of four of the buildings were calculated. The record does not even disclose whether the remediation dewatering at TS2 and the Fire Safety Training Area exceeds the estimated dewatering at the five buildings in Playa Vista. Take into account all the other dewatering that is going on at Playa Vista, including in Phase II, construction dewatering, and other remediation dewatering, including “toe drain” and “nuisance dewatering” and the Court can see how little information was actually provided to the public.

As will be discussed below, the City’s 2007 CLA Report process fails to comply with the procedural or substantive requirements of CEQA. The City claims it was an addendum, but never described it as an addendum, never treated it like an addendum and certainly never considered it with the 1993 EIR as required by law. The Court must overturn the lower court’s discharge of the writ and order it to deny the City’s return to writ. The City must learn to comply with CEQA.



## II. LEGAL FRAMEWORK

The basic purpose of CEQA is to provide the decisionmaker and the public with the environmental analysis necessary to ensure that the agency is fully informed of the environmental consequences of its decision before the project is approved. (Guidelines § 15002<sup>1</sup>; *Citizens of Goleta Valley v. Board of Supervisors* (1990) 52 Cal. 3d 553, 564.) "[T]he ultimate decision of whether to approve a project, be that decision right or wrong, is a nullity if based upon an EIR that does not provide the decision-makers, and the public, with the information about the project that is required by CEQA." (*San Joaquin Raptor/Wildlife Rescue Center v. County of Stanislaus* (1994) 27 Cal. App. 4th 713, 722 (quoting *Santiago County Water Dist. v. County of Orange* (1981) 118 Cal. App. 3d 818, 829).)

Such basic purpose and requirement does not disappear once the project is approved and the EIR is certified. While the EIR is deemed legally adequate after the time for challenging the EIR has passed, all agencies must consider the adequacy of the EIR upon any subsequent discretionary decision for the project. (Pub. Res. Code § 21167.2.) Upon the next discretionary decision, whether lead agency, or a responsible agency, must consider the project and the EIR to determine whether there are any changes to the project, changed circumstances, or new information rendering the prior environmental analysis inadequate to serve its informational purpose. (Pub. Res. Code § 21166.)

This is indisputable from the statutory framework. All levels of government must consider the environmental consequences and the environmental documents prepared for the project. (Guidelines § 15003(f).) For example, if a responsible agency must grant the next discretionary

---

<sup>1</sup> CEQA Guidelines are located at Title 14 of the California Code of Regulations section 15000 et. seq..

approval for the project, such agency must consider the EIR or Negative Declaration. (Guidelines § 15096(f).) While the Guidelines specify that a “A subsequent or supplemental EIR can be prepared only as provided in Sections 15162 or 15163,” this indicates that the responsible agency must determine whether the EIR is still legally adequate to describe the project and mitigate the impacts. The same process is necessary when the lead agency must grant the next discretionary approval. (Guidelines § 15162(c).) It must consider the prior EIR or negative declaration and consider whether any of the conditions identified in Public Resources section 21166 are present.

This basic theory, unchallenged by the Respondents, guides the Court’s review. The first step of the agency is to determine whether there have been any changes to the project, the circumstances or new information that requires changes to the EIR. (Guidelines § 15162.) This must be done by identifying the information not considered in the EIR. (*American Canyon Community United for Responsible Growth v. City of American Canyon* (2006) 145 Cal. App. 4th 1062, 1073-1074.) The second step is to identify whether changes to the EIR are major or minor, and whether the changes or new information causes new significant environmental effects not previously discussed in the EIR or substantially increase the severity of the environmental effects. (Guidelines § 15162(a).) Depending on the level of the changes and severity of the effects, the agency must prepare either a subsequent EIR, a supplemental EIR, an addendum or no further documentation. (Guidelines § 15162(d).)

At the end of the process, assuming that the agency proceeded in a manner required by law, and supported their decision on the level of environmental review, the Court has one more task. The Court must look at the environmental document prepared by the agency and determine whether the EIR as amended, whether by an addendum, by a subsequent EIR or by a

supplemental EIR, or by nothing, adequately serves to inform the public and the decisionmaker of the consequences of its decision. (Guidelines § 15151.)

### **III. 2007 CLA REPORT**

#### **A. THE 2007 CLA REPORT PROCESS WAS DESIGNED TO CREATE THE APPEARANCE OF SUBSTANTIAL EVIDENCE WHILE EXCLUDING CONTRADICTORY DATA OR OPINIONS**

Respondents claim that the 2007 CLA Report process went above and beyond the procedural requirements of CEQA. They claim that despite the lack of a requirement for public circulation, they held four public hearings (Resp. Brief at 22, fn. 9), contacted two state agencies (Resp. Brief at 20), and, of course, supplied all the relevant information. (Resp. Brief at 38-40.) However, additional proceedings are not a substitute for compliance with the letter of the law. It does not matter how many hearings are held, or how many state agencies are contacted, if the process omits relevant evidence and fails to produce an adequate document for informed decisionmaking. (Pub. Res. Code § 21003.1 and 21005.)

CEQA is premised upon “an interactive process of assessment of environmental impacts ... which must be genuine. It must be open to the public, premised upon a full and meaningful disclosure. . .” (*County of Inyo v. City of L.A.* (1984) 160 Cal. App. 3d 1178, 1185.) While perhaps the agency could later discount evidence, such as the list of industrial waste discharge permits for Playa Vista Phase I, or explain why the NPDES Permits showing additional dewatering operations are not relevant to their analysis of impacts, failing to provide such information to the public precludes informed public participation and decisionmaking. (*County of Amador v. El Dorado County Water Agency* (1999) 76 Cal. App. 4th 931,

946.) The City cannot hide behind its failure to gather or disclose relevant information to avoid challenges to its alleged substantial evidence. (*See, Sundstrom v. County of Mendocino* (1988) 202 Cal. App. 3d 296, 311 (discussing similar concept concerning a MND).) Substantial evidence must be evaluated in light of the whole record, not just the agency's supporting evidence. The whole record cannot be artificially truncated to support solely the agency's conclusions. (See Pub. Res. Code § 21167.6(e)(10) (record shall include any other written materials relevant to agencies compliance with CEQA or the project).)

As will be discussed below, the 2007 CLA Report was not a valid CEQA process. The procedure used by the City was focused solely on whether estimated dewatering from five buildings created a substantial impact on subsidence and plume migration. The analysis did not compare the 1993 EIR to determine available information or necessary project changes; did not consider the 1993 EIR when approving the project and 2007 CLA Report, and did not properly determine the baseline or cumulative impacts of the project in conjunction with all the other dewatering activities. The process failed to create a document sufficient to adequately inform the public and the decisionmakers of the environmental consequences of the decision.

**B. THE COURT IDENTIFIED THE CHANGES NECESSARY TO THE EIR AND DETERMINED THAT SUCH CHANGES COULD RESULT IN NEW SIGNIFICANT EFFECTS REQUIRING A SUPPLEMENTAL OR SUBSEQUENT EIR**

Respondents, unable to demonstrate any substantive review of the 1993 EIR in the record, argue that the necessary changes to the EIR were identified by the Court, which is should be sufficient to comply with CEQA. (Resp. Brief at 29.) Undoubtedly, the Court conducted a much more

thorough review of the 1993 EIR in drafting its prior decision than the City has done here. However, if the Court's review of the 1993 EIR is the basis of the City's decision, it certainly cannot change the findings of the Court of Appeal, which would require the preparation of a subsequent or supplemental EIR.

In this case, after reviewing the 1993 EIR, the Court held: "We conclude that the permanent groundwater dewatering contemplated in connection with the methane mitigation measures adopted by the city is a *potentially* substantial project change because it could result in those new or substantially more severe significant impacts." (1 CT 52-53.) CEQA's definition of "significant effect on the environment" is defined as "a substantial, or potentially substantial, adverse change in the environment." (Pub. Res. Code § 21068 (emphasis added).) Thus, because the Court already found that the project change may result in new significant effects the criteria triggering a subsequent of supplement EIR was already met. (Guidelines §§ 15162(a)(1), 15163(a).)

Consistent with the criteria of subsequent environmental review, the Court only provided two options, for the City to prepare a subsequent or supplemental EIR. The Court ordered the City "to vacate its approval of the methane mitigation measures, for the purpose of determining whether a subsequent or a supplemental EIR is required with respect to groundwater dewatering, and proceed accordingly as required by CEQA." (1 CT 62.) The Court could have easily ordered the City to determine whether a subsequent or supplemental EIR or an addendum was necessary, but it did not. (See, *City of San Jose v. Great Oaks Water Co.* (1987) 192 Cal. App. 3d 1005, 1017 (expressly mentioning an addendum as an option).) Thus, the only question for the City was whether the project change was major, requiring a subsequent EIR, or the change was minor, requiring a supplemental EIR.

Admittedly, there was sufficient ambiguity in the order that even the lower court would have preferred some clarification. (2 RT D-17.) Such ambiguity certainly prevented the Petitioners from enforcing the writ, or successfully bringing a contempt action. (2 RT D-36-38. ) Nevertheless, considering that Respondents now claim that the Court's review of the EIR in the ETINA I decision was legally sufficient to relieve the City of the duty to conduct its own comparison, then surely the City cannot complain that the Court found substantial evidence of new or substantially more severe significant effects requiring the preparation of a subsequent or supplemental EIR. The Court should deny the return of the writ and order Respondents to determine whether a Subsequent or Supplemental EIR should be prepared, and not prepare an addendum.

**C. THE CITY FAILED TO PROCEED IN A MANNER REQUIRED BY LAW BY FAILING TO IDENTIFY THE CHANGES NECESSARY TO CURE THE DEFECTS IN THE 1993 EIR**

Respondents claim that nothing in CEQA requires a comparison of the EIR to the addendum. (Resp. Brief at 29.) Such statement side-steps the argument. Assuming arguendo that the City even had the option of choosing to preparing something other than a subsequent or supplemental EIR, the first step to evaluating the level of environmental review is to identify the changes to the project that were not considered in the original environmental review document. (*American Canyon Community United for Responsible Growth v. City of American Canyon* (2006) 145 Cal. App. 4th 1062, 1073-74.) Without providing the decisionmaker with a comparison between the 1993 EIR and the new information about dewatering, the City Council cannot make a meaningful determination of how to comply with CEQA.

Despite claiming that a comparison of the review is not required, Respondents argue that they did, in fact, identify the changes necessary to the EIR. (Resp. Brief at 29.) This was allegedly done by relying on the Court's finding that the 1993 EIR did not discuss methane related dewatering, and repeating such finding in the 2007 CLA Report. (Resp. Brief at 29 citing 3 RR 471.) However, the 2007 CLA Report does not mention the 1993 EIR at all. (3 RR 471.) Respondents simply point to a recitation of the Court's decision in ETINA I, which does not mention the 1993 EIR. (3 RR 471.) The 2007 CLA Report's summary of the Court decision does not constitute review or consideration of the 1993 EIR.

Respondents further claim that comparing the 1993 EIR to the 2007 CLA Report would be a moot act – “there is simply nothing in the EIR against which to compare the 2007 CLA Report” (Resp. Brief at 29.) That is not true. While there may not have been a discussion about “methane related dewatering,” the 1993 EIR certainly discussed dewatering, and not just in terms of the Jefferson sewer project. (4 RR 822 at 40.) The EIR warned, “subterranean structures located in areas with a high groundwater table, if any, must be constructed in a way that minimizes the need for long term pumping, especially near the contaminant plume in area D.” (4 RR 822 at 40, 4264.) The 1993 EIR states under its cumulative impacts analysis, “Projects within the vicinity of the project site can be expected to impact the local ground water tables by affecting ground water levels should dewatering be required, with potential spreading of contaminants during excavation.” (4 RR 822 at 4266; See also 4264 (construction dewatering may lower water table); 4256 (saltwater intrusion.) But, the 1993 EIR concluded that “Excavation below ground water table for subterranean structures is not expected in Area D.” (4 RR 822 at 5311.) While the vast quantities of methane leaking at Playa Vista were not discovered until around 1999, and therefore the 1993 EIR could not have analyzed “methane related

dewatering,” the concerns about dewatering in general would have been invaluable for the City Council to consider. (5 RR 1024.)<sup>2</sup>

Nothing in the record demonstrates the City reviewed the EIR and identified the changes necessary to the EIR. The simple fact that both construction and permanent groundwater dewatering is occurring at Playa Vista, constitutes a major change to the project. The fact that Avalon, the building closest to the contamination plume, is undergoing significant permanent dewatering, is a major change, if not an outright violation of the mitigation measure requiring building to be designed to minimize the need for long term pumping, especially near the plume. Had the City actually identified the changes in the EIR, the City Council may very well have come to a vastly different conclusion.

In addition, had a comparison been conducted, the City Council might have wondered why the mitigation measures identified in the EIR were not followed. The primary mitigation measures were: first, avoid dewatering; second, if dewatering must occur, identify well locations and discharge rates; and third, create a plan for the beneficial use or discharge of the water. (4 RR 822 at 40.) Respondents argue that the mitigation measures identified only apply to the dewatering for the deep-gravity sewer, and not for other portions of the project. (Resp. Brief at 30-31.) However, the EIR states “before any long-term dewatering is conducted a plan for beneficial use or discharge...must be submitted and approved...” Further, at that time, the only expected long term dewatering was in connection with the deep gravity sewer and the remediation plant. (4 RR 822 at 4274.) In addition, the 1993 EIR explains that the remediation plant would use the remediated

---

<sup>2</sup> The concentrations of methane, described by the City’s expert, in the Playa Vista is truly frightening. (5 RR 908, 913 (methane bubbling through water), 5 RR 915 (62.9% to 76.16% methane concentrations 4 feet below surface).) In some areas, the methane coming through the ground is described as a macro-seep. (5 RR 913.).



groundwater to supply the freshwater marsh. (4 RR 822 at 4263, 4274.) Such statement contradicts Respondents' assertion that there is no beneficial use available for the groundwater. (Resp. Brief at 6 fn. 3.)

Respondents finally argue that the impacts of dewatering in the EIR were less than significant by the mitigation. (Resp. Brief at 30.) But, the mitigation measures were not implemented. As is evident from the claims of construction dewatering and the fact that at least five buildings in Playa Vista have permanent groundwater dewatering, dewatering has not been minimized. Further, there is no plan for beneficial use or discharge of the pumped water. Pumping groundwater into the sewer does nothing to help the environment, such as the constructed wetlands, and further taxes the City's infrastructure.

Failing to identify the changes in the 1993 EIR deprived the City Council of the ability to make an informed decision and the public the ability to comment on the proposals. The City failed to proceed in a manner required by law. The return to writ must be denied.

**D. THERE IS NO EVIDENCE THAT THE CITY COUNCIL MEMBERS CONSIDERED THE 1993 EIR IN CONJUNCTION WITH THE 2007 CLA REPORT**

In a related, but separate issue, one of the requirements for approving project changes or the same project despite changed circumstances or new information, is for the City Council to consider the EIR in conjunction with the addendum prior to approving the project. This is expressly stated in CEQA Guidelines, "The decisionmaking body shall consider the addendum with the final EIR or adopted negative declaration prior to making a decision on the project." (Guidelines § 15164.) The purpose of the addendum is to cure the informational deficiencies in the EIR. Because, as the name implies, the addendum "adds" to the EIR, or makes small or minor changes,

it cannot serve its informational purpose by being considered as a separate, independent document. Failing to consider the EIR in conjunction with the addendum constitutes an abuse of discretion. (Code Civ. Proc. § 1094.5.) “Only by requiring the [lead agency] to fully comply with the letter of the law can a subversion of the important public purpose of CEQA be avoided.” (*People v. County of Kern* (1974) 39 Cal. App. 3d 830, 842.)

As noted above, it is the decision maker, not agency staff that must consider the addendum with the EIR.<sup>3</sup> Respondents, to their credit, do not contend that the peer reviewers or City Staff’s alleged review the 1993 EIR was sufficient to satisfy the requirements of an addendum. (Resp. Brief at 26.) Instead, Respondents contend that the City Council did, in fact, review the 1993 EIR and 1995 MND/Addendum with the 2007 CLA Report. (Id.) Thus, the question for the Court is whether the record reveals the City’s Council review.

First, there is nothing in the 2007 CLA Report that describes the project as originally proposed or even mentions the 1993 EIR. The strongest evidence that the City can point to is a listing of the CD ROM containing the 1993 EIR as “Additional Documents Reviewed under the Initial Peer Review Reports.” (3 RR 481.)<sup>4</sup>

Respondents claim that no finding is required to state that the City Council considered the 1993 EIR in conjunction with the 2007 CLA Report. The only case which directly addresses the issue states that an express finding is necessary, but found harmless error when it was clear that the decision makers did, in fact, consider the EIR in conjunction with the addendum. (*Save San Francisco Bay Assn. v. San Francisco Bay*

---

<sup>3</sup> Despite Respondents assertion, this issue was adequately preserved for appeal. (14 CT 3248.)

<sup>4</sup> The City Council may have only had photo copy of the label of the CD, considering that the original record transmitted to the court contained only photo copies labels of the CD-ROMs.

*Conservation etc. Com.* (1992) 10 Cal. App. 4th 908, 935.) The *River Valley* case cited by Respondents addresses a different issue, whether findings to support the EIR, and more specifically, whether findings concerning “significant unavoidable affects” must be made again when approving an addendum to the EIR. (*River Valley Preservation Project v. Metropolitan Transit Development Bd.* (1995) 37 Cal. App. 4th 154, 177.) But, there is nothing to suggest in *River Valley* that the lead agency in that case failed to make a finding that it had reviewed the Final EIR. In fact, it is clear that the agency in *River Valley* was closely scrutinizing the EIR. (*Id.*)

Respondents cannot credibly argue that the City Council impliedly considered the EIR with the 2007 CLA Report. Respondents have not identified a single question, comment or anything from any of the City Council Members during the hearings that demonstrates an understanding that they were considering the 1993 EIR in conjunction with the 2007 CLA Report. The assertion that the EIR was somewhere in the administrative record is not an indication that the City Council considered the EIR. (*Kleist v. City of Glendale* (1976) 56 Cal. App. 3d 770, 777.) To accept Respondents' contention that listing the EIR in an index is sufficient would wipe out the mandatory requirement to consider the addendum with the Final EIR. (Guidelines § 15164.)

Furthermore, had the City Council been forced to make even that simple written finding - that it considered the 1993 EIR with the 2007 CLA Report in compliance with Guidelines section 15162 - then, at least the City Council Members would have been alerted to the duty to compare the information in the EIR with the information in the addendum. Such finding would have also alerted the public that the City considered the 2007 CLA Report an addendum, allowing them to respond appropriately. As it was, there was nothing in the 2007 CLA Report that identified itself as an addendum; there was no finding or indication in the 2007 CLA Report that

the City Council should consider the 2007 CLA Report with the 1993 EIR; there was no advice from the City Attorney that the City Council should consider the 1993 EIR in conjunction with the 2007 CLA Report; and there is no indication that the City Council took it upon themselves to consider the 1993 EIR with the 2007 CLA Report. The City failed to follow the procedures required by law, and the City's Return to Writ must be overturned. (Pub. Res. Code § 21168.)

**E. THE BASELINE OF THE CDM MODEL IS NOT ACCURATE AND BASELINE CONDITIONS WERE NOT PROPERLY DETERMINED OR DISCLOSED TO THE PUBLIC**

Respondents claim that because the City decided to rely on CDM's aquifer model, and such model is allegedly generally accepted by hydrologists, then the Court must accept that such model is valid and unassailable. (Opp. Brief at 14 & 35, citing *Nat'l Parks & Conservation Ass'n v. County of Riverside* (1999) 71 Cal. App. 4th 1341, 1364.) Respondents allege that modeling is accepted and often required under CEQA. (Resp. Brief at 35.) Respondents then go to great lengths discussing the modeling, asserting that CDM utilized industry-standard models developed by U.S. Governmental agencies. (Resp. Brief at 36.)

But, Petitioners are not attacking the use of a model. (Resp. Brief at 36.) Petitioners object to using estimates for determining the data used for the model. A model can only be accurate as the data used to support the model. The issue here is whether the baseline conditions used for the model were accurate and disclosed. (*Save Our Peninsula Committee v. Monterey County Bd. of Supervisors* (2001) 87 Cal. App. 4th 99, 120.)

As noted in the Kostka Treatise section cited by Respondents, "When precise data is not available, an EIR may rely on informed estimates." (Resp. Brief at 35 citing Kostka & Zischke, PRACTICE UNDER THE CAL.

ENVTL. QUALITY ACT (Cont. Ed. Bar 2010) § 11.34.) However, as discussed in *Save our Peninsula*, it is an abuse of discretion to use estimates to describe baseline conditions, in this case actual dewatering, when actual data is available. (*Id.* at 121.) Without an accurate determination of baseline conditions, the impacts cannot be evaluated. (*Id.*)

In this case the amount of dewatering from the four buildings was estimated to be 16,000 gallons per day. This was based on allegedly accurate readings from Avalon, after a 40% reduction, to find a “corrected” discharge of 209 gallons per day, “which was a perfect match to the measured groundwater discharge.” (3 RR 530.) Of course, the measurements were not provided in the record. The public cannot determine whether the estimate was a perfect match with a one day flow measurement, actual measurements averaged over a month, or the mean water discharge over a year. Such easily provided data is absent from the record.

Assuming that the measured Avalon groundwater discharge is accurate, there is no indication on how the discharge estimates for the other buildings were derived. No formula is provided in the record. No calculations are provided. There is no way for the public or the decisionmaker to evaluate the basis of the estimates. They are forced to simply accept (or reject) the estimates as accurate.

Furthermore, there is no legitimate reason to estimate the discharges from the other buildings. Like Avalon, the other buildings were complete, with functioning dewatering systems and industrial waste discharge permits and should have installed flow meters. Amazingly, Playa Vista prepared and provided a complex chemical analysis of the groundwater to determine that 40% of the discharge came from irrigation, but could not provide meter readings on all buildings.

The excuse for not using actual discharge volumes is explained by CDM:

Given the numerous variables, it was not possible to predict the effects of a complex groundwater system by measuring actual flows from the dewatering systems. For these reasons, CDM utilized the calibrated groundwater model to estimate the volume of water generated by the dewatering systems.

(1 RR 21.)

Such explanation makes little sense considering that the rates of discharge were input parameters for the model. The actual dewatering volumes or rates, like the estimated volumes, could have been imputed into the model. Failing to measure the volumes or, more likely, failing to disclose the actual volumes of dewatering places the results of the model in serious question. As noted by the Department of Toxic Substance Control, “the model results would be very sensitive to the changes of certain parameters.” (2 RR 210.) Obviously, a change in the amount of dewatering for methane may have an incredible impact on the results of the groundwater model.<sup>5</sup>

Furthermore, had the actual discharge volumes been disclosed, then the discrepancy between the two estimates for the Waterstone building (aka Product 102) would have been resolved. As discussed in Petitioners’ Opening Brief, an earlier estimate for the Waterstone building calculated groundwater discharges of 4,815 cu/ft. per day, which “corrected” is five times the “corrected” amount of 605 cu/ft per day estimated for CDM’s model. (32 Supp. RR 8541; 3 RR 530.)

Respondents do not dispute the accuracy of this earlier estimate. Instead, they claim that the estimate was for construction dewatering, not methane dewatering. (Resp. Brief at 41.) Unfortunately for Respondents, the record demonstrates that it was an estimate applicable to both

---

<sup>5</sup> The Regional Water Quality Control Board’s faith, or lack thereof, in CDM’s model is demonstrated by the demand for Playa Vista to install a sentinel well. (4 RR 778.)

construction dewatering and methane dewatering. The report states, “A dewatering system will be designed to keep the methane pipes free of water should groundwater rise, and to maintain dry working conditions in the temporary excavation during construction.” (32 Supp. RR 8540(emphasis added).) The report also states, “the inverts for the dewatering system pipes are planned for placement at the proposed pad grade, which ranges from El. +0.6 to +1.9” (Id.)<sup>6</sup> The reports estimates a 25 gallons per minute discharge, but recommends a dewatering system capacity of 100 gallon per minute for a two-level basement. (32 Supp. RR 8542.) In addition, the report states, “This does not include any surface water entering the basement though the access ramps from the street or other sources, and the actual dewatering system may have a higher capacity.” (Id.) Finally, the report estimates that the groundwater will be lowered nearly 4 feet, which is less than the actual lowering of groundwater as built. (32 Supp. RR 8542; 3 RR 555.)

Most damning to Respondents’ “construction dewatering theory” are the engineers’ hand-drawn schematics showing the basement with the “methane/dewatering system” along with all the engineers’ hand-written calculations. (32 Supp. RR 8694-8696.) Clearly, the engineer intended his estimates to be applicable to the permanent groundwater dewatering system.

The estimate provided by Playa Vista’s engineer in 2003 estimated a dewatering rate of 25 gallons per minute, or 36,000 gallons per day. He never contemplated surface water intrusion in his calculation. But, even if his calculations overestimated the actual discharge by 100%, Waterstone’s discharge would exceed CDM’s estimate of 16,000 gallons per day for all four buildings (16,000 gallons). Further, the earlier estimate for Waterstone was prepared when dewatering was simply an engineering issue, necessary to determine the design of the pumps. Playa Vista’s engineer at that time

---

<sup>6</sup> The actual elevation of the dewatering pipe at Waterstone is -1.0 MSL. (3 RR 555.)

had no reason to believe that his dewatering calculations would be reviewed by anyone else other than Playa Vista.

The pre-writ report and calculations greatly questions the accuracy and credibility of the modeling input parameters prepared by CDM. At the very least, the incredible discrepancy highlights the necessity of using the actual discharge rates from each of the buildings, instead of using unverifiable estimates. The failure to provide the actual discharge rates and volumes and instead rely on estimates constitutes an abuse of discretion under CEQA.

**F. THERE IS NO EVIDENCE IN THE RECORD THAT THE CITY CONDUCTED A CUMULATIVE IMPACTS ANALYSIS OF ALL DEWATERING**

Respondents swear that the City accounted for all dewatering at the Playa Vista site. (Resp. Brief at 43.) According to the brief, CDM took into account all past, present, and future dewatering activities at Playa Vista, including: historical groundwater pumping attributed to construction dewatering and ongoing remediation efforts at the site (Resp. Brief at 43); toe drain and nuisance dewatering (Resp. Brief at 44-45); Playa Vista Phase II (Resp. Brief at 47), and even the East Campus, which they erroneously claim, once again, is construction dewatering. (Resp. Brief at 46.) Mentioning such dewatering is not the same as analyzing such dewatering, nor is it the same as analyzing all such dewatering in a cumulative fashion.

Had the City actually prepared a cumulative impacts analysis it would have been easy to identify the answer to the key question. Does the total amount of dewatering occurring at Playa Vista exceed the recharge rate for



the aquifer?<sup>7</sup> However, a thorough review of the record yields no answer to this vital question. At best, the record yields a number of 1.2 inches per year of “recharge” from precipitation and an indecipherable mélange of numbers deep in the technical record discussing boundary inflow conditions. (3 RR 528, 8 RR 1574.) But the record does not yield an answer in any manner that the public can understand, as to whether the total amount of dewatering is slowly draining the aquifer.

The CEQA Guidelines are instructive on the type of cumulative analysis that should be included in an EIR.

[T]he following elements are necessary to an adequate discussion of cumulative impacts ....either:

- (A) A list of past, present and probable future projects producing related or cumulative impacts, including, if necessary, those project outside the control of the agency, or
- (B) A summary of projections contained in an adopted local, regional or statewide plan, or related documents, that describes or evaluates conditions contributing to the cumulative effect.

(Guidelines § 15130.)

While such guideline is applicable to an EIR, it is hard to imagine how an analysis of cumulative impacts in any environmental document prepared under CEQA would not start with a list of all the dewatering activities at Playa Vista and the volumes of each of their discharges. At the very least, sufficient information should have been provided demonstrating that the amount of dewatering, when considered in conjunction with past,

---

<sup>7</sup> There appears to be some dispute as to whether recharge includes solely rainfall recharge, or it includes boundary conditions, such as underground flows from outside of Playa Vista. Such distinction is irrelevant to Petitioners, interested in determining whether cumulative pumping is lowering groundwater levels, especially for the adjacent state protected Ballona Wetlands.

present and probable future projects, does not exceed the “recharge rate” of the aquifer. This information was not provided and therefore the 2007 CLA Report failed to create an EIR adequate for informed decisionmaking.

In fact, what is clear from the record, and Respondents’ brief, is that the 2007 CLA Report was anything but a cumulative impacts analysis. The report and the City distinguished groundwater dewatering from nuisance and toe drain dewatering despite the fact that rain and irrigation recharge the aquifer. (Resp. Brief at 7.) Respondents distinguish construction dewatering and remediation dewatering from methane dewatering. (Resp. Brief at 8.)

**G. THE CITY’S FAILURE TO PROVIDE THE PERTINENT DATA, MUCH LESS RAW DATA, PRECLUDED INFORMED PUBLIC PARTICIPATION AND PREVENTED THE PUBLIC FROM VERIFYING THE ACCURACY OF THE GROUNDWATER MODEL**

Respondents contend that the CD-ROM data disk provided to Petitioners was not corrupt and that they were not required to provide raw data to support their model. The first issue is an evidentiary issue, and the second issue is a legal issue easily resolved by reviewing the pertinent sections of CEQA and the CEQA Guidelines.

First, Respondents admit that the peer reviewers and the City had trouble reading certain files on the CD-Rom disks provided by Playa Vista. (Resp. Brief at 32.) Thus, Respondents sent a replacement disk to the peer reviewers and the City, ensuring that all the files could be opened. (8 RR 1512.) But, a replacement disk was never provided to the public. In fact, in the various responses to comments, the City claimed it was simply the Petitioners’ inability to use the MODFLOW program, not the disk, that was the problem.

Because of Petitioners' inability to read the data, despite attempting to use the MODFLOW program, Petitioners requested that the data be provided in "non-binary format." In other words, provide the input data in a manner that can be tested by third parties. Playa Vista refused.

But, it is not simply the raw data that is missing from the record, it is the relevant data. Had Petitioners been given the input parameters, they could have replicated the model. But, simple, basic information such as the total amount of dewatering at the site, the volumes and rates of discharges at the remediation wells and other important information was not provided in a verifiable format.

A prime example of this lack of basic information can be seen in the analysis of worse case scenario. While CDM explains many of the variables, the assumptions and the changes, the report fails to identify the amount of dewatering that is occurring. (4 RR 782.) Again, there is no way to determine the amount of dewatering occurring at the remediation wells. (Id.) Petitioners are certainly entitled to this kind of "raw data."

Respondents contend that there is "no authority to disclose raw data or permit 'independent verification' of the modeling. However, there is strong statutory authority within CEQA to disclose raw data to permit verification. For example, in discussing the information to be included in an EIR, CEQA states:

"Environmental impact report" means a detailed statement...provided that information or data which is relevant to such a statement and is a matter of public record or is generally available to the public need not be repeated in its entirety in such statement, but may be specifically cited as the source for conclusions stated therein; and provided further that such information or data shall be briefly described, that its relationship to the environmental impact report shall be indicated, and that the source thereof shall be reasonably available for inspection at a public place or public building.

(Pub. Res. Code § 21061 (emphasis added).)

The Guidelines specify:

The information contained in an EIR shall include summarized technical data, maps, plot plans, diagrams, and similar relevant information sufficient to permit full assessment of significant environmental impacts by reviewing agencies and members of the public. Placement of highly technical and specialized analysis and data in the body of an EIR should be avoided through inclusion of supporting information and analyses as appendices to the main body of the EIR.

(Guidelines section 15147 (emphasis added).)

While these sections specifically identify data to support conclusions in an EIR, there would not be any reason why any other kind of environmental review would permit the withholding of raw data. (See Pub. Res. Code §§ 21003.1 & 20005.) One of the express purposes of CEQA is, “to demonstrate to an apprehensive citizenry that the agency has, in fact, analyzed and considered the ecological implication of its actions.” (Guidelines 15003(d); *No Oil v. Los Angeles* (1974) 13 Cal. 3d 68, 86 (superseded on other grounds by Pub. Res. Code § 21082.2(b)).) Clearly, such policy cannot be accomplished without verifiable data.

The *Blue* case cited by Respondents is inapplicable and distinguishable on numerous grounds. (*Blue v. City of Los Angeles* (2006) 137 Cal. App. 4th 1131, 1135.) First, *Blue* is California Redevelopment Law case, not a CEQA case, and therefore does not have the same express duties to disclose as cited above. (*Id.* at 1134.) Most specifically, CEQA directs that “non-compliance with the information disclosure provisions of this division which precludes relevant information from being presented...may constitute a prejudicial abuse of discretion.” (Pub. Res. Code § 21005.) Case law finds that it is a prejudicial abuse of discretion if the omitted information precludes “informed decisionmaking and informed

public participation. (*County of Amador v. El Dorado County Water Agency* (1999) 76 Cal. App. 4th 931, 946.)

Secondly, in *Blue*, the Court notes that the information sought, the “Walker sheets” did not “preclude public participation.” (*Blue, supra*, 137 Cal. App. 4th at 1143.) The Court reasoned that actual existing conditions of the dilapidated properties constituted the actual raw data. “By inspecting the project area themselves, plaintiffs could have made their own assessment as to the accuracy of the information regarding conditions in the project area.” (*Id.*)

In this case, Petitioners cannot inspect the dewatering rates themselves. Petitioners cannot simply visit Playa Vista, take a picture of a building, and determine the extent of the dewatering of the aquifer. Such information must either come from Playa Vista, or the City. Basic information such as the volume and rate of discharge from the remediation wells used in the model is unavailable. The dewatering rates from the buildings in the “worse case scenario” model is unavailable. In this case, the raw data is required under CEQA, but even stating the unverifiable numbers would have provided Petitioners something to work with. The record demonstrates that the relevant data, whether raw or not, was simply not available.

Failure to provide verifiable raw data is an abuse of discretion. But in this case, relevant data, whether verifiable or not, was not available. The failure to provide the basis of the model constitutes an abuse of discretion and the Court should deny the return to writ.

///

///

///

**H. THE CITY COUNCIL NEVER DETERMINED WHETHER THE 50-FOOT VENT WELLS WOULD BE EFFECTIVE FOR THE LIFE OF THE PROJECT WITHOUT DEWATERING.**

The 50-foot vent wells provide an excellent example as to why a supplemental or subsequent EIR must be prepared, and why CEQA findings and CEQA mitigation should be imposed. (Pub. Res. Code § 21081; Guidelines § 15091.) First, as stated in the previous ETINA decision, the parties dispute whether the 50-foot deep vent wells require dewatering. (1 CT 53.) The Court of Appeal specifically found that it did not need to resolve the dispute.

Despite Respondents' attempt to mislead the Court otherwise, the City's peer reviewers did not consider whether the 50-ft vent wells required dewatering. (Resp. Brief at 42.) This is evident from a response to comments by Playa Vista which states, "the 50-foot vent wells were not considered or analyzed by the peer reviewers." (4 RR 833; See also, 3 RR 472 (describing the two tasks of the peer reviewers).) The 2007 CLA Report states in a conclusory manner "some of the commenters at the hearings believed incorrectly that the dewatering system at Playa Vista included "50-foot vent wells". (3 RR 472.) The 2007 CLA report also cites a LA Board of Engineering Report, which apart from the reference, states exactly the same thing as the 2007 CLA report. (6 RR 1277.)

Had the City Council actually considered whether the 50-foot vent wells adequately vented methane without dewatering, the City would be entitled to deference on its factual findings. (Pub. Res. Code § 21168.) But, the process deprived the City Council of the opportunity to consider public comments, discuss the conflict between experts, and impose performance criteria to ensure that the 50-foot vent wells remained unclogged and operational for the life of the project.

This is extremely important. As noted by the City's own experts in 2000, "due to the extremely high concentrations of methane contained in the 50 foot gravel aquifer....we believe the 50-foot aquifer also requires a mitigation system." (28 AR 7479.) The City expert continued,

If the pump and treat or equivalent methane mitigation system is not effective or if Playa Capital does not install an appropriate methane mitigation system in the 50 foot aquifer, we believe that the development should not proceed. Without the proper mitigation of the methane present, a dangerous situation exists at the site. No further development should be allowed on this site until these mitigation issues are resolved.

(Id.) The test wells were not successful, and many of them clogged. (5 RR 917; 3 RR 572.)

As pointed out by Respondents, there is a report prepared by CDM, Playa Vista's experts, regarding tests conducted on the installed 50 foot vent wells. Such report tested approximately 15 deep vent wells in August of 2005, and again in October of 2005, and found that methane was detected in excess of ambient air background at all of the deep vent wells. (3 RR 570 & 572.) However, as noted by Petitioners, some of the tests appeared to be from other vent wells, because the well identification numbers from August to October did not match. (*Compare* 3 RR 577 *with* 3 RR 596 (listing some different identification numbers "sample id" for the wells tested).) In addition, some wells show dramatic drops in methane concentrations between August and October. For example, well LTW-700-4 recorded 130,000 ppmv of methane in August 2005, and only 18.0 ppmv of methane in October 2005. (*Compare* 3 RR 583 *with* 3 RR 604.)<sup>8</sup> This would seem to

---

<sup>8</sup> Petitioners recognize that it is somewhat unfair to be citing to new portions of the administrative record on Reply. However, Petitioners did not want to be accused of not providing "an accurate and complete description of the evidence" with regard to the 50-foot vent wells. (Resp. Brief at 42, citing *Defend the Bay v. City of Irvine* (2004) 119 Cal. App. 4th 1261, 1266.)

indicate that the methane concentrations were reducing, which might indicate that the vent wells were slowly being clogged with silt.

And there was certainly the desire to investigate such issues. As complained by one City Councilmember:

“Look, our number one responsibility is the safety of our constituents . . . I’m confused enough to say I don’t understand why a supplemental EIR which might put his issue to bed wasn’t done in the last 13 months when we had all the time from last January to do it. Explain again, just from a safety standpoint. That’s what I care about is the safety of my people.” (2 RR 445.)

In response, City Staff replied, “all I can say to that is because the city attorney advised that under the law there is not a factual basis for the council to require a supplemental EIR.” (2 RR 446.)

The details are not particularly important at this point. What is important is that, there are dangerous concentrations of methane in the 50-foot aquifer, a conflict between experts as to whether the 50-foot deep vent wells require dewatering, and a City Council and public that was deprived of the opportunity to consider such issue. These vent wells must effectively vent for the life of the project which could be 80 to 100 years. A conclusory statement that dewatering for the 50-foot vent wells is not required leaves the issue as unresolved as the last time the Court reviewed this case. (1 CT 53.)

**I. PETITIONERS EXHAUSTED THEIR ADMINISTRATIVE REMEDIES BECAUSE THE CITY FAILED TO IDENTIFY THE 2007 CLA REPORT AS AN ADDENDUM**

Respondents simultaneously claim that the City was not required to identify the 2007 CLA Report as an addendum to the 1993 EIR, and that



Petitioners failed to exhaust their administrative remedies by failing to criticize the City's process of adopting an addendum. (Opp. Brief at 23-24.) The City cannot have it both ways. Clearly, Petitioners could not have complained that the 2007 CLA Report failed to meet the requirements of an addendum if the City never identified that they were considering an addendum to the 1993 EIR.

The purpose of the exhaustion doctrine is to provide an agency an opportunity to respond before those objections are subjected to judicial review. (*Woodward Park Homeowners Assn., Inc. v. City of Fresno* (2007) 150 Cal. App. 4th 683, 712.) If there is not an opportunity to raise objections, then the exhaustion doctrine does not apply. (*Id.* citing Pub. Res. Code § 21177(e).)

In this case, because there was no notice that the 2007 CLA Report was an addendum, there was no opportunity to object that the City was not following the proper procedure for an addendum. In fact, the first time that the City even mentioned that the 2007 CLA Report was an addendum was during the return to writ, 1.5 months after the final hearing. (12 CT 2790 (first claim that the 2007 CLA Report was an addendum).)

Not once during the administrative process did anyone with the City claim that the process was an addendum. (See, 2 RR 396-97 (no discussion at the hearing that the City was adopting an addendum).) There was no notice that the City was taking action pursuant to CEQA Guidelines section 15164. The public notice of the final City Council meeting identified the item as "Communication from the Chief Legislative Analysis relative to compliance with a writ of Mandate...and recommendations that City Council adopt [CEQA] findings on whether a supplemental or subsequent [EIR] is required..." (2 RR 387.)

The City provided three choices to the City Council Members – a Subsequent EIR, Supplemental EIR or neither. (2 RR 354, 356, 400, 436; 8

RR 1505.) In talking about the peer review, the City attorney noted, “There is no requirement of how you go about doing it or whether or not you have to send it to certain agencies or whether or not you have to write up certain findings on the peer review. It’s simply a study.” (2 RR 403.) The recitation of law in the 2007 CLA Report itself neglects to mention that an addendum is an option. Thus, by the City’s own statements the 2007 CLA Report is something completely separate from CEQA. As noted by the City Attorney herself, “it is simply a study.” If anything, the City decided to prepare “no further documentation” and abused its discretion in doing so.

Furthermore, it is not necessary to cite to the exact legal inadequacy as long as the agency is fairly apprised of the relevant facts and issues in dispute. (*McPherson v. City of Manhattan Beach* (2000) 78 Cal. App. 4th 1252, 1264.) There were numerous comments from the public objecting to the 2007 CLA Report and the need for a supplemental or subsequent EIR. (See, e.g., 1 RR 42 (Discussing the 1993 EIR.); (1 RR 187 (“The EIR is no longer valid”); (1 RR 190 (“The City cannot “approve” the project until the EIR is complete. The incomplete EIR can only become complete under CEQA compliance.”) (1 RR 198) (The CLA Report is improperly narrow and does not review the issues in light of the whole records as CEQA requires.”) These comments and many others are specific enough in a non-judicial setting to preserve the issues.

Finally, if there is a requirement that Petitioners make specific objections, then surely, there must be a corresponding requirement for the City to identify specifically what it was allegedly approving. But even when questioned, the City never identified the 2007 CLA Report as an addendum. Five days prior to the final hearing, Grassroots asks, “What action is being taken today? What does ‘adoption’ mean and entail?” (1 RR 184.) There was no notice that the City was considering an addendum in conjunction

with the 1993 EIR, because the City council never considered the 2007 CLA Report an addendum to the 1993 EIR.

#### IV. MOTION TO AUGMENT

**A. This Court May Consider Relevant and Improperly Excluded Extra-Record Documents Because Petitioners Have Proven Such Documents Fall Under the Exception Enunciated by the Supreme Court of California.**

Respondents contend that this Court may not consider two sets of relevant, extra-record documents: (1) documents from the LA City Department of Sanitation, including a table showing permitted discharges of up to 72,000 gallons per day, and (2) documents from the RWQCB showing permitted discharges of 950,000 gallons per day (“gpd”). (16 CT 3696-3700.) Though extra-record evidence is generally inadmissible, the Supreme Court of California has enunciated an exception to this general rule. “Extra-record evidence is admissible if the proponent shows that the evidence existed before the agency made its decision, but that it was impossible in the exercise of reasonable diligence to present it to the agency before the decision was made.” (See *Cadiz Land Co. v. Rail Cycle* (2000) 83 Cal. App. 4th 74, 119 quoting *Western States Petroleum Assn. v. Superior Court*, *supra*, 9 Cal. 4th 559, 576-578.) This exception corresponds with Code of Civil Procedure section 1094.5, subdivision (e), which grants the court discretion to remand the case for reconsideration if the court finds “there is relevant evidence, which, in the exercise of reasonable diligence, could not have been produced at the administrative hearing or which was improperly excluded.” (CCP § 1094.5.) Also, arguably, “extra-record evidence may be admissible to show ‘agency misconduct.’” (*Id.* at 119 quoting *Western States Petroleum Assn.*, *supra*, 9 Cal. 4th at pp. 575-576, fn. 5.)

The Court may properly consider the extra-record documents at issue

here because the documents demonstrate the City failed to consider maximum permitted discharges, even though such documents were in existence prior to the City's decision. Maximum permitted discharges are relevant both to an analysis of cumulative impacts, and to an analysis of potential worst-case scenario impacts for methane dewatering. Though Petitioners exercised reasonable diligence in requesting access to and inclusion of these documents, the City failed to comply. (Code Civ. Proc. § 1094.5(e).) This failure to include or consider these documents amounts to suppression of evidence and agency misconduct. Accordingly, the extra-record documents at issue here fall under the narrow exception articulated in *Western States* and Code of Civil Procedure section 1094.5(e). (*Western States Petroleum Assoc. v. Superior Court* (1995) 9 Cal. 4th 559, 576-578.)

**i. The Record of Proceedings Under Public Resources Code Section 21167.6(a) is Broad and Inclusive.**

Pursuant to Public Resources Code Section 21167.6(a), the record of proceedings shall include a broad array of documents "relating to the subject of the action or proceeding." Public Resources Code Section 21167.6(e) is inclusive, providing a list of items that "shall be included," but specifying that the record "is not limited to" those items. The statute "contemplates that the administrative record will include pretty much everything that ever came near a proposed development or to the agency's compliance with CEQA in responding to that development." (*County of Orange v. Superior Court* (2003) 113 Cal. App. 4th 1, 10.)

Indeed, the statute specifically mandates the inclusion of the following items:

Any other written materials relevant to the respondent public agency's compliance with this division or to its decision on the merits of the project, including the initial study, any drafts of any environmental document, or portions thereof, that have

been released for public review, and copies of studies or other documents relied upon in any environmental document prepared for the project and either made available to the public during the public review period or included in the respondent public agency's files on the project, and all internal agency communications, including staff notes and memoranda related to the project or to compliance with this division. (Emphasis added.) (Pub. Res. Code § 21167.6(e)(10).)

Thus, the City must include any written materials relevant to the City's compliance with CEQA, or to its decision on the merits of the project. (Pub. Res. Code § 21167.6(e)(10).) As specified by statute, this includes materials made available to the public during the review period, or included in the City's own files on the project. (Pub. Res. Code § 21167.6(e)(10).) As discussed below, the documents at issue here are directly relevant to the City's compliance with CEQA with respect to the project, and should properly be part of the administrative record, as mandated by Public Resources Code Section 21167.6(e)(10).

**ii. The Extra-Record Documents at Issue Here Are Relevant and Important to the Analysis of Cumulative Impacts and to Potential Worst Case Scenario Impacts**

Respondents contend that the information contained in the extra-record documents at issue is not relevant. (Resp. Brief at 51.) According to Respondents, the extra-record evidence “merely reflects maximum discharge volumes of numerous water types and is not reflective of probable groundwater discharges from methane system dewatering.” (Resp. Brief at 51.) Additionally, Respondents suggest the “technical analyses properly used accepted groundwater modeling techniques with calibration from actual data and did not rely on Bureau of Sanitation maximum permit discharge volumes.” (Resp. Brief at 51.) These arguments are without merit, and

directly contradict arguments made earlier in Respondents' brief. Further, the documents speak to the potential cumulative impacts of all dewatering activities on Playa Vista.

Documents reflecting maximum permitted discharges are directly relevant to an assessment of potentially substantial adverse impacts of methane system dewatering. (Pub. Res. Code § 21100.) Though Respondents argue that the Industrial Waste Discharge Permits are not relevant, Respondents' own report expressly notes that the five buildings have permitted discharge flows under the Industrial Waste Discharge Permits of 35,000 gpd. (3 RR 530.) Clearly, Respondent's expert felt the industrial waste discharge permits were sufficiently relevant to discuss.

Respondents claim that the Sanitation permits should not be considered because they incorporate "not only discharges from methane dewatering systems, but also nuisance and toe-drain surface water that has percolated down to the dewatering systems." (Resp. Brief at 39.) However, as noted in Respondents brief, the recharge rate is affected by rain and irrigation.

Respondents similarly argue that the information sheet on the NPDES permits should not be considered because the document "encompasses discharges not associated with methane system dewatering." (Resp. Brief at 40.) In addition, they argue that it is simply construction dewatering. However, NPDES permits establishing a maximum daily flow of 950,000 gpd, from three wells surrounding Playa Vista surely is affecting groundwater levels. (16 CT 3700.) A lead agency must determine not only whether direct and indirect effects of a project are significant, but also whether such impacts are cumulatively significant. (Guidelines §§ 15064(h)(1); 15065(a)(3).)

Respondents argue that the extra-record evidence is improper because it includes "permit information for buildings with contingent (as opposed to

permanent) dewatering systems that are not expected to actually discharge any groundwater.” (Resp. Brief, p. 39; 3 RR 514 (emphasis added) .) Respondents make much of this distinction between “permanent” and “contingent” dewatering systems. (Resp. Brief at 6-7; 3 RR 514.) However, the only real distinction is that the contingent systems are “not anticipated to collect groundwater unless the groundwater table rises. (Emphasis added.) (Id.) This, however, is based on Respondents’ admittedly moderate estimates. (Resp. Brief at 10-11.)

The true concern with exclusion of these documents is that someone outside of the public process is making decisions on what is relevant and what is not before the public and the decisionmaker has knowledge of the documents. The arguments made by Respondents against their relevance could have been made after such information was disclosed to the public, and the decisionmaker could have weighed the strength of such argument. Excluding such documents from the record prevented the public and the City Council from even considering whether such information was relevant. At the very least, these documents should be accepted in the record for the limited purpose of demonstrating that the cumulative analysis failed to identify all dewatering discharges.

**iii. The Extra-Record Documents at Issue Here Were in Existence Prior to the City’s Decision and Could Not be Produced at the Administrative Level in the Exercise of Reasonable Diligence.**

As discussed above, the extra-record documents at issue here should have been included in the record originally, pursuant to the terms of Public Resources Code Section 21167.6(e)(10). Nonetheless, this Court may consider these documents under the *Western States* exception because: (1) the evidence in question existed *before* the agency made its decision, and (2)

it was not possible in the exercise of reasonable diligence to present this evidence to the agency *before* the decision was made so that it could be considered and included in the administrative record. (*Western States Petroleum Assoc. v. Superior Court* (1995) 9 Cal. 4th 559, 578.)

Respondents contend that the extra-record evidence was not before the City Council. (Resp. Brief at 51.) To the contrary, these documents were in existence at the time of the hearing, and in possession of the City and RPI. Petitioners exercised reasonable diligence to obtain documents regarding Industrial Waste Discharge Permits and NPDES permits for buildings at the Playa Vista site. Petitioners submitted two Public Records Act requests, one on September 8, 2006, and one on October 10, 2006. (17 CT 3880-81.) However, Petitioners did not receive a response until May 8, 2007, well after the February 27, 2007 City Council hearing. (Id.) Had Petitioners received timely responses to its Public Records Act requests, such documents would have been submitted to the City for the hearing.

Dewatering information could have easily been provided by the Los Angeles Department of Sanitation, which issues Industrial Waste Discharge Permits. Despite repeated requests for such permits, the information was conspicuously absent from the record. (5 RR 859, 986, 7 RR 1327, 1357-58.) The City failed to disclose Industrial Waste Discharge Permits despite the clear relevance of the information and repeated requests for such information from Petitioners. (5 RR 985-86.) Likewise, the City failed to request from the applicant NPDES permits issued by the RWQCB. (Id.)

Respondents further suggest that Petitioners have an affirmative duty to acquire documents from the City and to submit those documents to the City. (Resp. Brief at 51; 15 CT 3586-87.) This would impose the ludicrous burden on Petitioners to obtain documents already in the City's possession, merely to return those same documents to the City for consideration. This notion shifts the burden of environmental investigation to the public.



Likewise, it was incumbent upon the City to request dewatering data from the RWQCB. Despite Petitioners' request that such data be evaluated, there is no evidence that the City requested NPDES permits or flow meter data from RWQCB. (5 RR 986.) The information is available from the Department of Sanitation and from the RWQCB, but the City failed to request or provide such information.

Without providing the total volume of all dewatering activities, neither the City nor the public can properly evaluate or participate in the public process. The City must "not be allowed to hide behind its own failure to gather relevant data. (*Sundstrom v. County of Mendocino* (1988) 202 Cal. App. 3d 296, 311.) "CEQA places the burden of environmental investigation on government rather than the public." (*Id.*)

**iv. The Circumstances Here Warrant Consideration of the Extra-Record Documents Because They Demonstrate Agency Misconduct and Suppression of Evidence in Violation of the Information Disclosure Requirements.**

Though the Supreme Court of California addressed a specific exception to the general exclusion of extra-record evidence, the Court did not "foreclose the possibility that extra-record evidence may be admissible . . . under unusual circumstances or for very limited purposes not presented in the case now before us." (*Western States Petroleum Assoc. v. Superior Court* (1995) 9 Cal. 4th 559, 578.) As noted in *Cadiz Land*, "extra-record evidence may be admissible to show 'agency misconduct.'" (*Cadiz Land Co. v. Rail Cycle* (2000) 83 Cal. App. 4th 74, 119 quoting *Western States Petroleum Assn., supra*, 9 Cal. 4th at pp. 575-576, fn. 5.) However, "extra-record evidence can never be admitted merely to contradict the evidence the administrative agency relied on in making a quasi-legislative decision or to raise a question regarding the wisdom of that decision." (*Id.* at 579.)

Petitioners do not seek this Court's consideration of extra-record evidence merely to contradict the evidence relied on by the City. Rather, Petitioners seek consideration of specific extra-record documents that relevant evidence was suppressed, despite Petitioners' reasonable diligence to have the documents included and considered.

The information disclosure provisions of CEQA provide that "preclud[ing] relevant information from being presented to the public agency, or noncompliance with substantive requirements of this division, may constitute a prejudicial abuse of discretion." (Pub. Res. Code § 21005.) This dovetails with Code of Civil Procedure section 1094.5 subsection (e), discussed above, which permits remand if "there is relevant evidence, which, in the exercise of reasonable diligence, could not have been produced at the administrative hearing or which was improperly excluded." (CCP § 1094.5(e).) Non-compliance with the information disclosure provisions constitutes a prejudicial abuse of discretion, regardless of whether the City would have come to a different conclusion. (Pub. Res. Code § 21005.) The City's failure to timely respond to Petitioners' requests for information violates the information disclosure provisions and Code of Civil Procedure section 1094.5.

The documents at issue here were requested by Petitioners in a timely fashion, well before the City Council hearing. The fact that the City ultimately provided the documents demonstrates that such documents were readily available to the City. (17 CT 003881.) It thus appears that the City's refusal to consider such documents amounts to suppression of evidence that did not support its desired outcome of no further environmental review. This kind of blatant agency misconduct warrants this Court's consideration of the extra-record documents. It would defeat the purposes of Public Resources Code Section 21005 to prohibit Petitioners from submitting documents to the Court demonstrating suppression of evidence. The most effective way for

Petitioners to prove that Respondents have violated the information disclosure provisions is to demonstrate to the Court that such documents exist.

The failure of the City to consider the Industrial Waste Discharge Permits and NPDES permits at issue here denied Petitioners and the public a full and open process. The City failed to disclose all the dewatering activities occurring at Playa Vista, though the data was readily available, making it impossible for the public or the decisionmaker to determine whether the dewatering will have a cumulatively significant impact. In order to effectuate the purposes of CEQA, the extra-record documents here should be permitted to demonstrate suppression of evidence, and to demonstrate the City did not consider the cumulative impacts of all sources of dewatering.

## **V. REQUEST FOR RECONSIDERATION OF ETINA I**

### **A. THERE IS NO WAIVER ON APPEAL BECAUSE THE TRIAL COURT DID NOT HAVE THE POWER TO REVERSE THE APPELLATE COURT**

As a preliminary matter, Respondents assert two procedural arguments. First, they argue in a footnote that Petitioners waived the right to request that the Court reconsider its prior decision by not raising the law of the case doctrine at the trial court level. However, a trial court does not have the power to change an appellate court's decision.

Ordinarily, an appellate court will not review an issue not properly raised at the trial court. (*In re Marriage of Moschetta* (1994) 25 Cal. App. 4th 1218, 1227.) "It is important to remember, however, that the purpose of this general rule is to give the trial court and parties an opportunity to correct an error that *could* be corrected . . . in the trial court." (*Woodward Park*

*Homeowners Assn., Inc. v. City of Fresno* (2007) 150 Cal. App. 4th 683, 712.) It would be an exercise in futility to argue an issue that cannot be corrected at the trial court level. (Cf. *Automotive Management Group, Inc. v. New Motor Vehicle Bd.* (1993) 20 Cal. App. 4th 1002, 1015 (administrative exhaustion doctrine not applicable in cases of futility.) In this case, the trial court was bound to follow the opinion of the appellate court, and could not reconsider the issue under any circumstance. (*Butler v. Superior Court* (2002) 104 Cal. App. 4th 979, 982.)

In addition, as discussed in *Woodward*, “a noncurable defect of substance where the question is one of law is not an error that falls within the rule.” (*Woodward Park Homeowners, supra*, 150 Cal. App. 4th at 712.) In this case, the previous ruling of the Court is one of law - - the applicability of Guidelines § 15162 to the newly discovered existence of large quantities methane at Playa Vista.

Finally, *Woodward* notes that “a matter of public interest” also does not fall under the waiver doctrine. (*Id.*) The *Woodward* court specifically applied the waiver doctrine to CEQA, noting “the baseline issue [under CEQA] we have just discussed falls within both of these exceptions.” (*Id.*) *Woodward* specifically held,

“The question is whether the environmental documents were adequate as a matter of law. This is, of course, a question of law ... Further, the determination of whether the agency has complied with CEQA before approving a major development project in a densely populated area is an issue of public interest.”

(*Id.* at 714.)

Likewise, in this case, the issue of whether the City’s procedure for analyzing the discovery of methane at Playa Vista complied with the requirements of CEQA is a question of law. Clearly, the issue of approving

massive development bringing a dense population to an area that is releasing explosive gas would be a matter of public interest.

**B. REQUEST FOR SUPREME COURT REVIEW OR RECONSIDERATION CANNOT NOT HAVE BEEN EXPECTED WHEN PETITIONERS APPEARED TO RECEIVED THEIR REQUESTED RELIEF IN A SUBSEQUENT OR SUPPLEMENTAL EIR.**

The second procedural hurdle that Respondents argue should bar Petitioners' request for the Court to revisit and overturn its previous decision is the fact that Petitioners did not request Supreme Court review or request reconsideration from the appellate court. (Resp. Brief at 55.) This appears to be based on some type of equitable argument. (Id. citing *People v. Scott* (2000) 85 Cal. App. 4th 905.)

*People v. Scott* is a convoluted criminal case touching on issues of double jeopardy and retrial. (Id. at 908.) In the end, the Court found that the Law of the Case doctrine did not apply if new or other evidence was presented by the State on retrial. (Id. at 925.) But, such case has nothing to do with whether the failure to request rehearing or seek Supreme Court review creates a procedural bar to seeking to avoid the Law of the Case doctrine based on exceptional circumstances.

Furthermore, it must be remembered that Petitioners prevailed in ETINA I. Petitioners obtained their desired relief, a ruling that the approval of the methane mitigation measures must be vacated. In addition, it appeared to Petitioners that the Court ordered the City of Los Angeles to prepare a Subsequent or Supplemental EIR. While the issue of whether the City had substantial evidence to support its finding that the methane mitigation measures would reduce the impact of methane to a level of insignificance, the Court expressly left unresolved whether the 50' deep vent wells required

dewatering. (1 CT 53, fn. 11.) Considering that the City's own expert noted both that the 50-foot vent wells required a pump and treat system to be operational, and that the 50-foot vents wells were absolutely necessary to build in the area, the question of whether the development could safely constructed was still on the table. (5 RR 899-900, 28 AR 7479.)

Of course, Petitioners could not anticipate that Respondents would only provide lip service to the Court's order to vacate the methane mitigation measures, and would continue to build and inspect methane mitigation systems, including dewatering systems, and issue certificates of occupancy at Playa Vista. (2 CT 381-383.) In addition, Petitioners could not anticipate that the City would refuse to evaluate whether the 50-foot vent wells would sufficiently vent methane from the 50-foot aquifer for the life of the project. (4 RR 833.)

Demanding that Petitioners request rehearing or seek Supreme Court review in a case where they appeared to have obtained their ultimate relief, is demanding too much. Finally, the fact that the Respondents failed to stop or even slow down construction begs the question – what exactly would be inequitable in the Court reviewing its previous decision? Playa Vista, throughout the entire litigation, has proceeded with construction at its own risk and peril. There are no equitable principals that would bar the Court from reconsidering the issues of law, despite the Law of the Case doctrine.

**C. THE EXPLOSIVE NATURE OF METHANE AND IMPORTANT CEQA PRINCIPALS ARE EXCEPTIONAL CIRCUMSTANCES JUSTIFYING THE RECONSIDERATION OF ETINA I.**

Methane is explosive in concentrations between 5% and 15%. (30 AR 7817.) Clearly, the possibility of people dying in a fiery explosion

constitutes exceptional circumstances. There is no more important role for government than ensuring the health, safety and welfare of its citizens.

The discovery of methane at Playa Vista should have given any rational decisionmaker concerns about the wisdom of building at the site. If anything, this demonstrates the necessity of a thorough environmental review at the earliest stage possible. As noted by the Court of Appeal, “It is all too likely that if such activities proceed pending preparation of an adequate EIR, momentum will build and the project will be approved, no matter how severe the environmental consequences.” (*San Joaquin Raptor/Wildlife Rescue Ctr. V. County of Stanislaus* (1994) 27 Cal. App. 4th 713, 741.) Who can deny that, had Playa Vista approached the City in 1993 proposing to build 3,000 plus residential units on the largest methane leak in the Western United States, the City Council would have been hesitant to approve the project.

Respondents argue that the City held six public meetings and received opinions from six outside consultants. (Resp. Brief at 57.) However, the City never considered alternatives such as locating building outside of areas with high methane concentrations. Under CEQA, “the key question and first step in analysis is whether any significant effects of the project would be avoided or substantially lessened by putting the project in another location.” (Guidelines § 15126.6(f)(2).) A CEQA-like process is not CEQA. In fact, the primary purpose of the 2001 CLA Report was to evaluate whether methane could be mitigated, not whether it should be mitigated. (See 4 AR 1051-52 (2001 CLA Report stating the five primary questions reviewed).)

Further, CEQA is a doctrine of accountability. “If CEQA is scrupulously followed, the public will know the basis on which its responsible officials either approve or reject environmentally significant action, and the public, being duly informed, can respond accordingly to action with which it disagrees.” (*Laurel Heights Improvement Assn. v. Regents of University of California* (1988) 47 Cal. 3d 376, 392.)

Unfortunately, the accountability purpose of CEQA has been sidestepped through-out this entire process. The 1993 City Council, in approving the entire project, did not know about the presence of large quantities of methane. The 2001 City Council was not given the option of changing the project or denying the project, and instead simply “note and filed” a report on methane, and directed the implementation of mitigation measures.

Thus, the 2001 City Council was not tasked with approving mixed use commercial and residential in an area of high levels of methane. They did not consider alternatives, as would be required in a SEIR. Because no SEIR was prepared, the City Council never had the task of considering whether it was wise to build in areas of the highest level of methane.

The 2007 Los Angeles City Council is even more removed and insulated from the decision of building on an incredibly dangerous methane leak. They are tasked with determining whether dewatering associated with the methane mitigation measures is a significant impact, and if so, how to mitigate it. What City Council person is going to deny the approval of a dewatering system, regardless of the impacts, when such dewatering system is critical to the functioning of the methane mitigation systems?

Equipment does break down, necessary inspections are missed, maintenance, which is now the responsibility of numerous third party building owners and Homeowners Associations, is deferred, and the unthinkable can happen. (5 RR 1039; See also, 5 RR 1055 & 1079 noting numerous deficiencies with LA DBS inspection and code enforcement.) There is always a chance that a clogged pipe, an improperly wired detections system, or the unavoidable, but entirely foreseeable earthquake will release large quantities of methane into a building. When the methane level reaches between 5% and 15% concentrations, any ignition source will cause catastrophic injury.



The City and Real Parties-in-Interest are desperate to avoid a Subsequent or Supplemental EIR. An SEIR, like all EIRs, must comply with notice requirements, respond to comments, identify and analysis alternatives and alternative locations, and consider a no project alternative. Importantly, the City Council will have to approve or disapprove a project in area with methane macro-seeps. Should the City Council be willing to permit construction in a high methane area, they may have to explain why they are willing to risk lives in a statement of overriding considerations (Guidelines § 15093.) If the CEQA process works correctly, the public will know the environmental and safety ethics of the City Council members, and may vote accordingly. (*Laurel Heights, supra*, 47 Cal. 3d at 392.) At the very least, when people are asking, “how did this disaster happen?” they can identify the specific elected officials responsible. The CLA process accomplishes none of this. This case constitutes the kind of exceptional circumstances that should elicit the willingness of the Court of Appeal to double check the questions of law in the underlying case, and ensure that they have properly applied CEQA.

**D. THE COURT SHOULD BE WILLING TO REVIEW THE QUESTION OF LAW STATED IN ETINA I, AND STATE THE PROPER INTERPRETATION OF CEQA GUIDELINE SECTION 15162**

Petitioners challenge the statement, “A new or more severe significant effect does not require the preparation of a subsequent EIR or supplement to an EIR, however, if adopted mitigation measures will reduce the impact to a level of insignificance.” (1 CT 42.) The sole question for the Court is simply whether such statement is a correct statement of law. After all, the purpose of the Court of Appeal is to review questions of law.

Admittedly, it is somewhat unusual to request that the Court review its own prior decision. But, it is not uncommon for Courts to overturn their own previous decisions in other case. For example, the Fourth District Court of Appeal noted in one of its CEQA cases,

We further note our deferential approach taken in *Uhler v. City of Encinitas* (1991) 227 Cal. App. 3d 795 [278 Cal. Rptr. 157], is inconsistent with the standard of review we apply in this case. In *Uhler*, we stated we may not substitute our judgment for that of the agency which certified a negative declaration, mistakenly applying the deferential substantial evidence standard of review. (*Id.* at pp. 802-803.) Accordingly, we candidly admit the *Uhler* standard of review cannot be reconciled with the correct standard of review we adopt in this case, and, as a result, we now abandon the erroneous standard we applied in *Uhler*.

(*Quail Botanical Gardens Foundation, Inc. v. City of Encinitas* (1994) 29 Cal. App. 4th 1597, 1603.) And it is certainly common for other appellate districts to criticize, distinguish and just disagree with other appellate courts. (See e.g., *Pocket Protectors v. City of Sacramento* (2004) 124 Cal. App. 4th 903, 935 criticizing another case.) Surely, overturning an erroneous statement on the standard of review is akin to overturning an incorrect statement of law proffered in the same case. The most important task of the Court of Appeal is to correctly state the law.

In our request, the only relevant task is to determine whether the above challenged statement of law is consistent with CEQA Guidelines section 15162. Respondents give short shrift to the argument simply stating that Petitioners ignore the public policy behind Public Resources Code section 21166, that after the initial review, the public policy shifts in favor of finality over public comment. (Resp. Brief at 59.) Petitioners agree with such general statement of law. However, such public policy is accomplished by not permitting the re-opening of an EIR until the next discretionary

decision, if any, and by requiring substantial evidence to support the conditions requiring a supplemental EIR outlined in Public Resources Code section 21166 and CEQA Guidelines § 15162.

Guidelines section 15162 plainly states that a subsequent EIR is required if "The project will have one of more significant effects not discussed in the previous EIR or negative declaration." (Guidelines § 15162(a)(3)(A).) It is beyond dispute that the discovery of heavy concentrations of an explosive gas is a significant effect. The very fact that methane mitigation measures were required indicates that it was determined to be a significant effect. (Guidelines § 15126.2(a); 15126.4(a)(3).) However, nothing in the Guidelines imposes an additional burden to prove that proposed mitigation cannot mitigate the impacts to a level of insignificance. (Guidelines § 15162.) Such a burden would nullify the informational purpose behind the preparation of a subsequent or supplemental EIR. Indeed, an agency could circumvent additional environmental review in most instances, by drumming up an expert willing to state that such and such mitigation will reduce the significant effect to a level of insignificance.

Respondents complain that Petitioners argument concentrated on the *River Valley* case, and did not address the other cases contained in the court's footnote. (Resp. Brief at 58 citing ETINA I (1 CT 42).) First, the *River Valley* case was the focus of the Court in ETINA I, and the source of the misapplication of law. Secondly, the other case cited by the court, are not particularly instructive on this particular point of law.

The *STOP* case stands for the unremarkable proposition that reducing a project in size does not require the preparation of a subsequent EIR. (*Snarled Traffic Obstructs Progress v. City & County of San Francisco* (1999) 74 Cal. App. 4th 793, 801.) The alleged mitigation measures pointed out by this Court were voluntarily incorporated into the project, and were not

mitigating new significant impacts. As noted in *STOP*, there was no firm commitment at that time to a particular configuration of the project. The revised project proposal would thus not necessarily entail new and negative aesthetic impacts. (*Id.* at 802.)

In the *Benton* case, the County prepared a subsequent mitigated negative declaration to an earlier mitigated negative declaration. (*Benton v. Bd. of Supervisors* (1991) 226 Cal. App. 3d 1467, 1473 & 1483.) *Benton* might suggest that a subsequent mitigated negative declaration might have sufficed, but the Guidelines indicate that such option is only available to cure a previous negative declaration. (See Guidelines § 15162(b)(applying specifically after the adoption of a negative declaration).) Whatever the applicability of *Benton*, there is nothing in *Benton* to suggest that mitigating a new significant impact would relieve an agency of any further CEQA review.

However, the *Longbeach* case did permit the preparation of a mitigated negative declaration after the preparation of an EIR. (*Long Beach Sav. & Loan Ass'n v. Long Beach Redevelopment Agency* (1986) 188 Cal. App. 3d 249, 266.) But, clearly traffic had been studied in the previous EIR, and the issues in *Long Beach* concerned changes in the project and not new information. (*Id.* at 255.) Further, the issue before the Court in ETINA I was whether allegedly mitigating a new significant impact, not studied in the previous EIR, could relieve the agency from all further environmental review. Such concept is simply not supported by the *Longbeach* case, and certainly not supported by the Guidelines as currently written.

The Guidelines require the preparation of a subsequent or supplemental EIR whenever “[n]ew information of substantial importance ... shows any of the following: (A) The project will have one or more significant effects not discussed in the previous EIR or negative declaration.” (Guidelines § 15162(a)(3).) The presence of high concentrations of methane

is clearly a significant effect. If there was ever a time for the Court to reconsider its prior ruling, it is now with lives at stake. Without fully evaluating the alternatives and considering the risks and consequences, the City Council should not stake people's lives on the gamble that sump pumps won't break down and large tubes stuck in the mud will not clog. And if they are willing to take such gamble, they should state their reasoning on the record. The Court should require a supplemental or subsequent EIR to evaluate the new discovery of methane.

## VI. CONCLUSION

The Return to Writ should be denied with directions to prepare a subsequent EIR or supplemental EIR for both methane and dewatering. An SEIR is absolutely necessary in this case because of the extreme danger methane poses. The public needs the City Council to actually consider alternatives and risks, and if mitigation is actually feasible, to impose a mitigation monitoring program that is actually enforceable and verifiable for the next 100 years.

The 2007 CLA Report, whatever it was, did not comply with procedural requirements of CEQA. It could not have been an addendum because the record shows no comparison or consideration by the decisionmakers of the 1993 EIR. It did not add nor cure the deficiencies in the 1993 EIR. As stated by the City Attorney, "its just a study", nothing more.

Further, the Court should specify that all dewatering in the Playa Vista area must be disclosed, including actual amounts, locations and purpose. In addition, the City of Los Angeles should be ordered to comply with CEQA by considering all new information of substantial importance that has arisen since the 1993 EIR and the 1995 MND/Addendum.

Petitioners respectfully request costs on appeal and to be determined the prevailing party for the purpose of Code of Civil Procedure section 1021.5.

Respectfully Submitted,

DATE:

LAW OFFICE OF TODD T. CARDIFF

---

Todd T. Cardiff, Esq.

Attorney for Petitioners and Appellants  
**ETINA, GRASSROOTS COALITION**  
and **DANIEL COHEN**

**FROM: Grassroots Coalition,**  
Patricia McPherson, President  
Patriciamcpherson1@verizon.net

**August 2, 2012**

**TO:**  
**California Coastal Conservancy**  
Attn. Executive Director, San Schuchat &  
All Governing Board Member and Alternates

CC  
John Chiang- CA. State Controller  
Matosantos- CA. Dept. of Finance Director  
Bill Lockyer- CA. State Treasurer  
John Laird- Dept. of Natural Resources  
U.S. Army Corps of Engineers Attn. Commander Mark Toy  
U.S. Senator Barbara Boxer  
U.S. Congress Person Maxine Waters  
L.A.Councilman Bill Rosendahl

**RE: Complaint-** Supporting the 3/29/12 REQUEST TO RESCIND APPROVAL FOR STAFF RECOMMENDATION APPROVAL ON 1/19/12 awarding \$6,490,00. for: FILE NO. 04-088-

**BALLONA WETLANDS RESTORATION ENGINEERING AND TECHNICAL STUDIES**

The following paper from Grassroots Coalition (GC) represents GC's opinion of its findings and data support garnered via the Public Record Act and the Freedom of Information Act.

**This document also requests the Coastal Conservancy to stop its illegitimate interference in the approved and ongoing 2005 Joint EIS/EIR process between the Sponsor-- Santa Monica Bay Restoration Commission (SMBRC)/ LA County Flood Control and, the U.S. Army Corps of Engineers.**

**The Coastal Conservancy, using its control over public bond money, has shut out the public process and taken its influence as a financially powerful board member of the SMBRC and partner of the California Department of Fish & Game (DFG), the lead agency of the publically owned Ballona Wetlands—to fund a process that is contradictory to the 2005 federal process that was requested by Congress.**

**The Coastal Conservancy is propelling a bait and switch – a NEW Joint EIR/EIS process and a NEW Notice of Intent (NOI) that undermines and attempts to extinguish the current 2005 Joint EIS/EIR APPROVED PROCESS with its attendant safeguards of multiple habitat restoration alternatives.**

**The Coastal Conservancy is instead, illegitimately propelling a singular outcome that stops restoration of Ballona and protection of its endangered species to instead convert the habitat into a non-historical dredged out estuarine habitat that promotes LA Port expansion and other financial deals.**

**Background:**

In 2004, Ballona Wetlands acreage was purchased via PUBLIC funding for approximately \$140 million. **The land is owned by the public** and is currently administered by the California Dept. of Fish and Game (freshwater marsh portion by the State Lands Commission) .

**Important, new information** contained herein reflects a Coastal Conservancy (CC) Public Record Act (PRA) response consisting of numerous heretofore undisclosed CC documents contained on a CD. The CD was provided after the 1/19/12 CC Governing Board Hearing in Los Angeles, CA. and, after the CC Governing Board's Hearing in Ventura, CA. on 3/29/12.

**I.**

**The Coastal Conservancy PRA CD provides evidence to show that misleading and/or incorrect information was presented in the Staff Recommendation of 1/19/12 (File No. 04-088)**

The newly disclosed Coastal Conservancy documents (CD) reveal:

- A. potential misuse of public bond money (Prop. 12, PRC 5096.352 (f) and or (b)(1));
- B. lack of disclosure, lack of public process and transparency of process regarding the Coastal Conservancy's involvement and; associations with other agencies --federal- US Army Corps of Engineers (USACE) and; state agencies and; a private nonprofit- the Santa Monica Bay Restoration Foundation (Foundation) that pertain to Ballona Wetlands in Los Angeles, CA.
- C. Prop. 12 ( Number 172 of Dept. of Natural Resources Listing of Prop. 12 bond grants; 3760-30203-0005(2)(B)07) Coastal Conservancy bond grant to The Southern California Coastal Water Research Project (SCWRP) -Ballona Wetlands Restoration. The Coastal Conservancy, contrary to the bond grant language and intention of allowing for a "scientific advisory committee" (SAC) to review and advise regarding '**enhancement**' plans for the restoration goals of Ballona Wetlands; the Coastal Conservancy instead propelled and directed SCCWRP members and other contractors to perform a singular outcome of '**creation**' of a full tidal/ estuarine, non-historical , **treatment wetland as an end of pipe, experimental solution to the toxic contamination of Ballona Creek.**



The CC Staff Recommendation is a non-historically oriented goal and thus fails to adhere to bond language for “enhancement” of Ballona Wetlands and also fails to adhere to “restoration” as defined by Southern California Wetlands Recovery Project (SCWRP). (See p.3 SCWRP restoration definition) And, contrary to publically stated and written goals of transparency and interchange, the CC and SMBRC precluded the public and Working Group from participating and interfacing with SAC. Thus, the CC and SMBRC, utilizing all public bond dollars have effectively shut the public out of the Ballona Wetland Restoration design process.

Contrary to comments made below in the Staff Recommendation 1/19/12 (File No. 04-088), the conceptual restoration plan was **not** developed in a public process and the public and other parties were **precluded** from participation in all facets of the development of the restoration alternatives

*“Cooperation: The conceptual restoration plan was developed in a public process with input from a Science Advisory Committee, an Agency Advisor Committee, and the Ballona Working Group made up of representatives of local nonprofit organizations, agency staff and members of the public. Individual public members also participated in all facets of the development of the restoration alternatives.”*  
(p. 9 of 9 1/19/12 Staff Recommendation; Emphasis added.)

The CD documents reveal that the conceptual restoration plan was developed by the Coastal Conservancy and by the executive director and staff of Santa Monica Bay Restoration Commission- a California state agency.

**Note- the SMBRC Commission’s executive director and most staff are not state personnel . Since 2005, the executive director and staff of the SMBR Foundation (a private 501c3) simultaneously act as SMBRC staff and executive director. IRS records reveal payment to the Foundation’s executive director and staff from the Foundation. We have found no contractual authority for such private persons to serve as state officers of a state agency or as staff of a state agency. We are currently requesting an assessment and investigation into these matters of great public concern.**

The CD documents reveal that the Coastal Conservancy Staff Recommendation was created:

1. in a void of public/ Working Group input acknowledgement and use.
2. in a vacuum of interchange between the Scientific Advisory Committee and the public/ Working Group and the USACE contractual agreements.
3. while failing to disclose scientific findings to all parties and;
4. while failing to provide process as written by the Coastal Conservancy.
5. without adherence to the 2005, contractual agreement between the United States Army Corps of Engineers (USACE) and the Sponsor (aka the Authority-SMBRC & LA County Flood Control) wherein a Joint EIR/ EIS of Corps certified programs of environmental review would take place and;

6. without CC Governing Board authorization and without public disclosure-- the CC Project Manager created an enterprise consisting of a 'new' Joint EIR/EIS process ostensibly intended to circumvent the 2005 approved process. (JD submission to CC 3/29/12)

- 7.

Lack of Disclosure Has Led To An Inability To Make Informed Decisions

I.

**A. Proposition 12 Funds-The Public's Intent - To Acquire, Protect and Restore Is Not Fulfilled.**

The Prop. 12, Public Resource Code (PRC) Section 5096.352 language states, “ (f) Twenty-five million dollars (\$25,000,000) of the funds shall be allocated to **acquire, protect, and restore** wetlands projects that are a minimum of 400 acres in size in any county with a population greater than 5,000,000. (Emphasis added. The Ballona Wetlands is distinguished as fulfilling this specific criteria.)

**Restoration**—specifically refers to actions taken to obtain a former state of a **natural condition**. (Southern California Wetlands Recovery Project (SCWRP)- Science Advisory Panel (SAP)- Glossary of Terms)

**Estuarine wetlands**- are subtidal and intertidal habitats that are semi-enclosed by land, have access to the open ocean, and in which ocean water is at least occasionally diluted by freshwater runoff from the land (Cowardin et. Al. 1979)SCWRP, SAP Glossary)

. Ballona was not historically continually open and connected to the ocean and large, inundating flows of fresh water occurred infrequently only during major flood events (CD- SAC docs; USGS docs provided to CC by J. Davis; CC's T-sheets).

**“The project we are recommending is enormous in scale.”** CC- MarySmall (JD PRA Response attachment in 3/28/12 CC Hearing-Request )

**Contrary to “protecting and restoring” the Ballona habitat**, the approval of the Engineering and Technical Studies & SMBRC bond awards will specifically promote a **singular** outcome— massive destruction of currently functioning habitat that will **not** ‘obtain a former state of a natural condition’ but, will instead endeavor upon a non-historically oriented, experimental estuarine treatment wetland project expected to encounter yearly flooding and scouring events. The project is not expected to be self-sustaining but instead expected to promote a perpetual money pit of contracts for monitoring and unknown but expected repairs and fixes- - future landscape changes further transfiguring the flora and fauna. (CD/SAC)

A failure to adhere to grant proposal requirements, as dictated by the State of Ca. Finance Dept. in recent audits, continues

NOTE: While the Coastal Conservancy promotes the idea that it provides bond grants to the SMBRC, the Coastal Conservancy has actually never provided any bond money to the SMBRC as per the 2002,

SB 1381 Keuhl bill that established a Treasury Account for the SMBRC. Instead, the Coastal Conservancy provides public bond money grants to the private nonprofit—the SMBRFoundation—typically without a grant proposal having been provided—as is the case in the 1/19/12 grant approval.

Recent audits of the CC by the California Dept. of Finance require that the CC adhere to grant proposal requirements established by the Dept of Finance. However, the CC's failure to adhere continues as is the case in the 1/19/12 grant approval.

The currently clean land (LARWQCB) and functioning habitats—include endangered and rare Southern California native plants and wildlife, which will be destroyed in order to create the end of pipe, treatment wetland for toxic Ballona Creek waters and sediments. ( CD-SAC) The full tidal, estuarine goal also appears to discharge political favors for LA Port expansion(s) approvals that need wetland mitigation credit(s) and/or extensive fill material from Ballona.  
(See e-mails regarding LA Port - letters of support for the Staff Recommendation)

**Contrary to the 8/13/04 CC MEMO (p.4),** the CD -SAC documents reveal wildlife and habitat destruction and dangers, endless and exorbitant financial costs, inability to show sustainability and potential legal quagmires that were not revealed to the public/ Working Group and other parties-- some of whom were asked to sign onto Coastal Conservancy pre-scripted letters of support for the 1/19/12 Staff Recommendation.\*

\*Contrary to the promised 'transparency' of process; CC and SMBRC staff improperly lobbied for letters of support for the 1/19/12 Staff Recommendation prior to a public notification of an agenda and release of the Staff Report thusly, discriminating against all others by failing to provide the same comment opportunity prior to the issuance of the Staff Report.

The public has a right to know the full extent of issues regarding changes to Ballona. Whatever decisions are rendered, they should not be based upon piecemealed, truncated and biased information as has currently been provided.

### **PROPOSITION 12 Identification of Funds; Status of Funds**

The Staff Recommendation(SR) is unclear which Proposition 12 funds are being requested. Two possible funding sections of Prop. 12 are:

- Proposition 12 bond money discussed in the SR as specifically for Ballona Wetlands is listed under Public Resource Code (PRC) Section 5096.352 (f)). The accounting for these funds was not provided in the Staff Recommendation and remains unknown.

-Other Prop 12 funds include: PRC Section 5096.352(b)(1)—to the Santa Monica Bay Restoration Project/Bay Watershed Council; that account status remains unclear also.

(In 2002, Senate Bill 1381 (Keuhl) transformed the SMBR“Project” into the SMBRCommission. Prop. 12, PRC language utilizes the Bay Watershed Council. The ByLaws of the the Bay Watershed Council (BWC) remained intact which now give rise to

questions regarding the actual existence of the BWC after SB 1381 which may influence the use of the Prop 12 bond funds.)

## I.

### **B. 5-6. The Coastal Conservancy Project Manager and SMBRC Executive Director/ Staff, Have Not Been Forthright With the Public Regarding Disclosure of Process Changes Pertaining to Federal (USACE) Contractual Agreements**

#### **U.S. ARMY CORPS OF ENGINEERS**

1994, Sept.28 Adopted- "Resolved by the Committee on Public Works and Transportation of the United States House of Representatives, That the Secretary of the Army is requested to review the report of the Chief of Engineers on Playa del Rey Inlet and Basin, Venice, California published as House Document 389, Eighty-third Congress, Second Session, and other pertinent reports, to determine whether modifications of the recommendations contained therein are advisable at the present time, in the interest of navigation, hurricane and storm damage reduction, environmental restoration and other purposes at Marina del Rey Harbor, Los Angeles, California, with consideration given to the disposal of contaminated sediments from the entrance channel required under the existing operation and maintenance program at Marina del Rey Harbor."

In 2005, USACE Noticed and embarked upon an areawide ecological review- an EIS- of the historic Ballona Wetlands area that included the U.S. 83th Congress -- House Document 389 under Public Law 780. Map-Enclosure No. 1 (General Plan of Improvement) reveals the entire Ballona region as part of this action including but not limited to Ballona Lagoon, Del Rey Lagoon and the Sanctuary area , Ballona Creek, Centinela Creek etc. (See language of the USACE Lower Ballona Creek Restoration Reconnaissance Study and; Feasibility Study). This EIS was predicated upon having a local Sponsor as part of the review process and to aid in the outreach to the PUBLIC and the creation of the Joint EIR/EIS process.

SMBRC/LA Flood Control (the Authority) aka the Sponsor-- contractually agreed to the Joint EIR/EIS in 2005.

The contract included having the Sponsor (Authority) provide at least 6 public meetings dedicated to providing time for USACE representatives to discuss the USACE status of the Joint EIR/ EIS process. The follow through for such meetings has not occurred.

(In various earlier approved bond requests for Ballona projects; Project Manager Mary Small eliminates reference to the 2005 contractual agreement for a Joint EIR/EIS which jointly provides for the Ballona Restoration Alternatives ( 2005 contract between- USACE and SMBRC/LA Flood Control aka Authority) Instead Ms. Small's staff recommendations inform the CC Governing Board that as of 2005 only the Ca. Dept. of Fish & Game, State Lands Commission and SMBRC are part of the oversight of Ballona and alludes that the Conservancy has the restoration alternatives planning duties:

(Ballona Wetland Improved Public Access; File No. 04-088; 7/21/10)

*"In 2005, the Conservancy initiated conceptual planning and feasibility analysis of restoration alternatives*

*for the property. This project is being implemented in partnership with the DFG and the State Lands Commission, the two state agency owners of the property and the Santa Monica Bay Restoration Commission. The feasibility analysis was completed in 2008, after a delay due to the bond freeze, and the project partners are now initiating environmental review and detailed engineering of a long-term, phased restoration project. When the restoration planning began, the Conservancy funded the development of an Interim Site Stewardship Plan to address the pressing concerns related to site management. As discussed above, in 2008 the Conservancy provided a grant to MRCA to fund construction of some site improvements and to fund planning, design and preparation of permit applications for additional access improvements. Based on the completed planning work, the MRCA and the project partners determined that it will be more cost effective and logical to pursue implementation of most access improvements as part of the environmental review and permitting for the long-term phased restoration project.*

**PROJECT FINANCING:**

Coastal Conservancy \$280,000

MRCA 120,000

SMBRC, US EPA funds 20,000

Total Project Cost \$420,000”

This is an omission of pertinent and critical fact given in order to garner public bond money. ( See J. Davis 3/28/12 Request to CC Gov. Brd.; USACE/CC minutes of meeting(s) and page 6)

See also File No. 04-088 on page 17.

Additionally, the bond money was approved but accountability for its use has not been forthcoming. And,

No fund award was given to SMBRC from the USEPA as cited above. The Treasury Account set up for the SMBRC under SB1381 was not utilized. Instead, ostensibly the USEPA funds went to the private nonprofit, the Foundation. The Foundation, as a private non-profit 501c3, provides no accountability to the public.

The Coastal Conservancy, had also made promises to the public regarding transparency and public inclusion in the entire process of exploring **all reasonable alternatives for enhancement of Ballona**.

For example in an early Coastal Conservancy MEMO dated 8/13/04 to California Department of Fish & Game (DFG) and the State Lands Commission (SLC), the **GOALS/PRINCIPALS** read in part-

***“The restoration plan will be based on the best science, incorporate technical scientific expertise and will be developed through a transparent planning process that allows stakeholders to provide input and comment on all restoration planning products. The restoration planning process will develop and analyze a range of alternatives to implement the following project goals:***

***-Restore and enhance a mix of wetland habitats to benefit endangered and threatened species as well as other migratory and resident species;  
-Provide for wildlife-oriented public access and recreation opportunities; and –  
Implement a technically feasible, cost effective, ecologically beneficial and sustainable restoration.” (Emphasis added.)***

And,

*“..restoration will be conducted within the landscape and watershed context, with attention paid to adjacent and ecologically related resources.” Pg. 1*

According to CD documents, the Coastal Conservancy’s Ballona project manager participated in USACE meetings in the 2004 timeframe citing inclusion of the areawide ecosystem eg. Ballona Lagoon, Del Rey Lagoon, the Sanctuary area, Marina del Rey and others that paralleled the activities of ecosystem review as described by the USACE ( Reconnaissance Study; Lower Ballona Creek Restoration Feasibility Study; 3/28/12 J.Davis submission to CC)

However, in contradiction to the 8/13/04 Memo cited above, the context of the larger historic boundaries of Ballona Wetlands were later arbitrarily dropped, without public notification or discussion. The CC Project Manager discusses no longer including the adjacent and ecologically related resources as part of the Joint EIR/EIS restoration evaluation performed with the USACE:

6/2/10 CC, SMBRC, USACE Ballona Coordination Meeting Minutes:

*“II. b. Mary Small: Have all the PMP sections looked at the same project area? Parts still refer to Ballona Lagoon, Grand Canal, Venice Canals and Oxford Basin, which are no longer in the study area. ( 3/28/12 CC hearing; J. Davis Attachment)*

**And, the Project Manager discusses instead a ‘new’ process for which there is no ostensible authority and to which the public has not been made aware:**

*“Mary Small: If the Corps falls too behind, we will work with Corps Regulatory for a permit for their activities (NEPA/CEQA, design, permitting, and Phase 1 construction)” and;*

*“Mary Small: It was always our understanding that the Corps would use our restoration alternatives. It makes us nervous that this was never in writing.”(6/28/10 Ballona Ecosystem Restoration Planning Management Meeting)*

It was never the public’s understanding that the Corps would be held to Coastal Conservancy and Foundation staff’s restoration alternatives. Legal legitimacy for such behavior is also questionable. And,

*“Suggested response*

- 1) The EIS/EIR process begun in 2005 was for the Army Corps’ Lower Ballona Ecosystem Restoration Feasibility Study, that project and the associated environmental review has not been completed and is not moving forward at this time. The EIR/S process for the proposed enhancement project will be separate.” 2/7/12*

CC/Mary Small to Ca.Dept. Fish & Game- Rick Mayfield per response to Davis Ballona CEQA process query. (JDavis attachment 3/28/12 Request to CC Board)

Thus, the CC switch in process is 'suggested' to be disclosed to a member of the public after seeking and garnering approval for the 1/19/12 Staff Recommendation. ( 3/28/12 CC Hearing, Davis PRA attachment to Request)

This new and unauthorized process discussion continues in the same email, 2/7/12, from Shelley Luce to Mary Small and Rick Mayfield (CDFG):

..." ***The EIR/EIS that we want to start is for a separate project, i.e. the BWER restoration/ enhancement project.*** ".. (emphasis added.)

The EIR/EIS that they want to start IS NOT on a separate project but instead on the same project but having eliminated the '94/ 2005 Joint EIR/EIS process; scope of review; environmental safeguards and full range of alternatives inherent in '94/ 2005 approved process.

In other words, the CC attempts to have the public and the USACE but out of their way so that the CC can control the project --using the public's dollar--alongside its political allies.

And, while Mary Small provides the appearance that the Request For Proposals is new online--" *the request for services ....went out today*"....

2/8/12 CC email (JDavis PRA response attachment in 3/28/12 Request to CC Board)

The Coastal Conservancy, had already put out an online RFP in 2010 for the work requested for approval in the 1/19/12 Staff Recommendation. Thus, it appears that as of 2010, the outcome was already a done deal behind the public scene.

Changes, such as this were not communicated to the Public/ Working Group and the ongoing status of the relationship with the USACE as per the Joint EIR/EIS was not communicated either. In fact, the USACE- Sect. of the Army was not made aware of the attempt to extinguish the earlier, approved process. Any extinguishing of the approved EIR/EIS process (including House Document 389) would have to abide by the USACE process of removal. The process provides accountability for reasoning as to the ending of the project as well as detailed accounting for money spent and what had occurred throughout the process. This activity has not occurred and the USACE has provided a letter stipulating that the approved process is maintained and that investigation into the matter has started. ( USACE-J.Davis communication).

It is also unclear whether USACE/SPONSOR information was communicated to the Science Advisory Committee or other parties. Specific USACE work projects, including response to House Document 389 and work quality/certification needs are not communicated in any of the CD-SAC meeting notes which appears to show that the SAC team (contracted and paid for with public funds) were fulfilling ONLY the arbitrary GOALS as set forth by the CC Project Manager and SMBRC staff. Issues

such as the protection of groundwater (classified as potential drinking water), an issue of House Doc. 389 and current Los Angeles- Best Management Practices (BMPs) are absent in the meeting minutes.

Thus, the CC and SMBRC staff, provided for an atmosphere of further disconnect, lack of transparency and compartmentalization of information sharing.

And,

the public/Working Group was not made aware that the CC considered itself a part of the USACE/SPONSOR contract (which it is not) —so much a part, that Mary Small apparently believed that the CC would provide the alternative(s) for the USACE in the Joint EIR/EIS:

6/28/10 Ecosystem Restoration Planning Management Meeting:

II. C. 2." *Mary Small: It was always our understanding that the Corps would use our restoration alternatives. It makes us nervous that this was never in writing."*..

This type of very questionable influence was not conveyed publically. According to the USACE, Joint EIR/EIS language, the USACE study would provide for all reasonable alternatives and the process would embrace public disclosure and participation.

**The Coastal Conservancy and SMBRC staff have not been forthright with the public regarding status of the Joint EIR/EIS.**

#### I.

**B. 1- 3. The CD reveals SAC meetings, reports and concerns not shared with the public/the Working Group and other parties. Conversely, the public/ Working Group comments and concerns are not cross- shared.**

Contrary to the 1/19/12 Staff Recommendation, the public, Working Group and others have not been engaged by the Coastal Conservancy as promised and have not been provided with full information from the Science Advisory Committee (SAC) group in order to make informed decisions and provide input throughout the process to date.

Prop. 12 bond money was also provided from the Natural Resources Dept. to the Coastal Conservancy specifically to provide a GRANT to the Southern California Coastal Waters Research Project (SCCWRP)(#172) for creation of a SAC team. Thus, the SAC team was paid with public dollars to perform as an independent scientific advisory panel to provide input and advice regarding historical restoration options. Contrary to the GRANT purposes, the Coastal Conservancy's Ballona Project Manager and SMBRC staff instead told the SAC team what the intended outcome was and that all input was to secure that goal—namely full tidal estuarine and levy removal.

Thus, the Prop. 12 bond money was not utilized as intended.

The Coastal Conservancy and SMBRC staff kept the public and the Working Group out of the SAC loop of information and knowledge thereby thwarting and distancing



any meaningful interchanges and participation as falsely stated in the Staff Recommendation below.

**Staff Recommendation excerpt:**

*“Cooperation: The conceptual restoration plan was developed in a public process with input from a Science Advisory Committee, an Agency Advisor Committee, and the Ballona Working Group made up of representatives of local nonprofit organizations, agency staff and members of the public. Individual public members also participated in all facets of the development of the restoration alternatives.”*

(p. 9 of 9 Staff Recommendation 1/19/12)

And, contrary to assurances that the public would be notified and included on all SAC meetings, the public was not notified or included.

*“MARY S. all SAC meeting are public, all interested parties will be notified and invited, meetings will be structured with SAC addressing issues first and public comment period at the end.”* (CD- 7/20/05 LMU Ballona SAC MTG.)

A 2004 MEMO discusses –

“Ballona Restoration Planning Working Group: Stakeholder Committee and Public Involvement

*“A Ballona Restoration Planning Working Group (brpwg) made up of interested organizations, agencies, and individuals, will meet periodically to obtain project status updates, to provide input, and to support the restoration planning process. These meetings will be open to the public. Subcommittees may be established to address specific issues that may arise during planning.”*pg.2

The language above provided for the public involvement at the start of the process that began with ‘interim stewardship’ meetings, (eg. trash cleanup and education tours) which did occur. As time passed, meetings stopped, informational sharing from agencies and the science team became nonexistent and; the public’s comments were not included in the planning process that continued behind closed doors.

**-Website topic- SAC meeting minutes- was not accessible to the public.**

**Instead, when clicked – the website told the viewer entry was not allowed.**

**-SAC meetings, though described as open to the public, were not. The CD documents reveal that the SAC meetings were, in the main, telephonic and not inclusive of the public. Reports and Memos were not shared with the public but utilized internally.**

A continued failure to acknowledge the public and Working Group is also documented via the 2012 Science Advisory Meeting that was held days after the Staff Recommendation Approval. The SAC meeting was also a first in years for actually occurring and, that public notice was provided.

The Public/ the Working Group:

- provided strong objections to the proposed Plan, providing written testimony as well as oral testimony.
- listed issues that needed to be addressed properly; asked for responses that thus far have gone unanswered and,
- again requested the area be considered in its totality of ecosystem variety and benefits utilizing the historic system of Ballona.
- reminded the SAC that the area now has more saltwater --deep and mid habitat than historically existed at Ballona due to the Marina del Rey; Ballona Lagoon Marine Preserve; Del Rey Lagoon; Ballona Creek itself and; as well as freshwater due to the newly created catch-basin- aka, the freshwater marsh. (historically= the last couple hundred years)
- SAC numerical analysis of habitat types was in error. Ratios of entire Ballona Wetlands historic habitat applied to be fulfilled in Areas A, B, C alone is a faulty analysis. The SAC- ratio numbers that pertained to former water habitat and land elevations were either incorrect and/or not documented by SAC.
- cited and documented that SAC dredge spoils deposition locations and volumes were incorrect. (USGS Documents and maps provided by John Davis to the Coastal Conservancy)

The CC and SMBRC continue to fail to respond.

**Note: The CC continues to fail to respond to queries and comments provided by the public and its so-called "Working Group" members from 1/19/12 and 3/29/12.**

#### **FAILURE TO INCLUDE THE WORKING GROUP COMMENTS AND REQUESTS**

Despite providing comments, documentation and evidence regarding the topics listed above and others; there is no documentation provided from the Coastal Conservancy on the CD that any of the public/ Working Group communications were included for any meaningful response or use.

The CD documents reveal no inclusion of the public in any decision making for the alternatives.

Public comments provided to SMBRC and the Coastal Conservancy regarding Ballona specific studies such as the Phil Williams & Assoc. report, that did not address or incorrectly addressed issues, such as the migrating oilfield gas and reservoir gas leakage from SOCALGAS had no meaningful response. There is no showing that the CC or SMBRC staff ever shared these concerns with the SAC team, much less did any meaningful, good faith follow up with the public to understand how the gases may impact restoration. The same holds true for issues regarding protection and utilization of the Ballona aquifer groundwater hydrology. Repeated requests from stakeholders to be given ½ hour presentation time to provide information regarding hydrology and groundwater diversion issues, before the SMBRC have been met with silence ( The CC is part of the SMBRC) .

I.B.

**CONTROL OF MESSAGE AND OUTCOME**

**The CC and SMBRC Staff :**

**Allow For No Public/ Working Group Participation In The Planning Process;  
Fail to Disclose Science Advisory Committee (SAC) Conference Calls,  
Memorandums and Reports For Planning of Alternatives;  
Feasibility, Cost, Sustainability, Ecosystem Pros and Cons Are Not Disclosed;  
And  
The CC & SMBRC Staff Arbitrarily Define Project Goal=Estaurine**

**Staff Recommendation excerpt:**

*"Cooperation: The conceptual restoration plan was developed in a public process with input from a Science Advisory Committee, an Agency Advisor Committee, and the Ballona Working Group made up of representatives of local nonprofit organizations, agency staff and members of the public. Individual public members also participated in all facets of the development of the restoration alternatives."*

(p. 9 of 9 Staff Recommendation 1/19/12)

**The 1/19/12 Staff Recommendation excerpt is false.** The public/ Working Group was neither privy to the SAC meetings and information created nor included in the planning process to participate in all facets of the development of the restoration alternatives.

The following excerpts from the CD document an internal discussion revealing the CC and SMBRC staff created and controlled the alternative selection:

*"Wayne (Wayne Ferren) suggested that biological sustainability be defined as no loss of habitat types & functions, major guilds, and sensitive species over the project site as a whole." July 7, 2008 SAC Conference Call.*

And;

*"Joy (Joy Zedler) asked how biodiversity is being defined? Sean indicated that **biodiversity = highest richness of estuarine dependent species.** If this is how we are defining biodiversity, it should be stated clearly in the document. (emphasis added; Sean Berquist was SMBRC staff and Foundation staff during this timeframe ) and,*

*"Wayne suggested that we clarify that biodiversity is the sustainable richness of representative interdependent native estuarine habitats along with their associated and expected species biodiversity." (CD-June 23, 2008 SAC Conference Call)*

The next pararrgraph, written by the note-taker- cited by CC as being CC or SMBRC staff- states the goal-

**"Estuarine biodiversity is the primary objective of the analysis."**

(CD- June 23, 2008 SAC Conference Call Memo)

This same Memo also sets forth a GOAL that was not shared with the public/ Working Group.

*"The project goal is to create functional estuarine habitat...";*

***"1. Maximize area of estuarine habitat.";***

*Opportunities to create regionally significant habitat including vernal pools and...should be pursued but **not at the expense of restoration of estuarine habitat.**"*

The public/Working Group was not allowed to participate in the decision making and was not advised as to the differing opinions rendered by the SAC team.

Since this timeframe and without public notification or disclosure the Coastal Conservancy and staff of the Foundation have worked to eliminate the areawide review of ecosystem function and alternative habitat plans—including a public debate regarding the pros and cons of each system -- to instead focus upon a predetermined singular outcome of removal of Ballona Creek levees and dredging of Ballona to 'landscape' and convert the land from its historic natural function to an entirely new, artificial and unnatural function that precludes all habitat function that does not primarily promote the estuarine full tidal premise.

And though asked publically where this 'Plan- Alternative 5 ' came from, no response has been forthcoming from either the CC or Foundation staff.

The CD docs however now shed light as to the creation of this "preferred plan". The overtones of financial leverage dominate the first half of the letter and serve to advance a predetermined outcome that is seen fulfilled in the Coastal Conservancy Staff Recommendation—the removal of levees to create the treatment wetlands.

July 10, 2007 SMBRC letter from Shelley Luce to Coastal Conservancy's Ballona Project Manager- Mary Small:

*"Dear Mary,*

*The Santa Monica Bay Restoration Commission, a National Estuary Program of the US EPA, has been pleased to participate in the acquisition and restoration of the Ballona wetlands at all levels over the last several years. We are proud partners in the restoration planning, and currently have one staff member dedicated full time to the planning effort, while I serve on the Ballona Wetlands Science Advisory Committee (SAC). The SMBRC is also an active local partner in the Army Corps of Engineers' Lower Ballona Ecosystem Restoration Feasibility Study and are participating in clean up and restoration plans for Ballona Lagoon, the Grand Canal, Marine del Rey and the Oxford Basin. We have also awarded several millions of dollars of bond monies under our purview to projects designed to improve water quality and habitat in the Ballona Creek watershed. Ballona wetlands restoration is clearly a very high priority of the SMBRC and the EPA.*

*I have reviewed the restoration design alternatives that are being developed by the consulting team and I am disappointed that they do not fully consider important restoration options, thereby limiting potential habitat, biodiversity and water quality improvements in the wetlands complex. The Ballona SAC requested design alternatives that encompass the "extremes" of restoration planning, i.e. from minimal intervention to maximal structural changes, as well as alternatives in between. The current proposed*

*alternatives do not provide this and need to be modified, or an additional (fourth) alternative is needed.*

*SMBRC feels that the restoration design for Ballona wetlands must represent a true restoration of maximum ecological functions and services for the area. Actual restoration work will not begin for months or years, and will be a long term and costly process. The best approach is to include design alternatives that are not limited by current infrastructure or fiscal concerns, since these factors will certainly change over the duration of the restoration process. Similarly, factors such as poor water quality in Ballona Creek will continue to change as Total Maximum Daily Loads and other regulatory measures are implemented. It does not serve us to design the restoration as though it would be undertaken and completed in the very near future, under existing physical or financial constraints.*

*I would like to request that the design team include at least one design alternative that proposes to*

- remove all or part of the levees on one or both sides of Ballona Creek;*
- daylight the channel connecting the freshwater marsh to the creek in Area B, and Stingray Creek to Marina del Rey in Area A;*
- raise Culver Boulevard to increase flows between the north and south sections of Area B; and*
- increase connectivity between Ballona Creek and Areas A and B.”*

*Our staff Wetlands Restoration Manager Sean Bergquist is available to work closely with the consulting team to ensure the revised or new alternatives include features that stakeholders and the SAC members supported. The revised or new alternatives should be presented as one of the group of alternatives for consideration under CEQA and by stakeholders and the SAC.*

*Given our experience in and commitment to the Ballona wetlands and surrounding interconnected areas, the SMBRC staff, Governing Board and Watershed Council have a great deal to contribute to the restoration process. Please feel free to consult us further during development of the restoration design alternatives and we look forward to continuing our partnership to restore Ballona wetlands.*

*Sincerely,*

*Shelley Luce, D.Env.*

*Executive Director*

An e-mail 7/17/07 from SMBRC Commission & Foundation executive officer Shelley Luce,

“RE: design alternative for Ballona wetland restoration” and Phil Williams & Associates’ (PWA) Jeremy Lowe –

“We’ve sketched out Alternative 5 as described in Shelley’s letter. Is this what you were envisaging?”

Luce: “ Thank you for your response Jeremy. This is a good start for a 5<sup>th</sup> alternative. Sean and Jessica are adding/changing some details and will forward to you. “

(presumably-Sean Berquist and Jessica Hall– both Foundation paid staff/ SMBRC staff)

The CD documents also reveal two sets of drawings and plans for the levy removal and levy replacement—by Jessica Hall, a Foundation paid staffer.

---

Ms. Luce is the Executive Director of the Foundation; no contractual

agreements

have been produced by the SMBRC Commission or the State Water Board that provide any authority for her to act in capacity of Executive Director of the State Agency-

Santa Monica Bay Restoration Commission which was created under SB 1381 Keuhl as a non regulatory state agency within the State Water Board. There have been no contractual agreements forthcoming by the State Water Board or federal authorities that provide for any SMBRC or federal EPA- National Estuary Program (NEP)- dedicated funding to be handed over to the SMBR Foundation. There is a treasury account that was formed under SB1381 in 2002.

The treasury account has never been used. The attendant oversight and accountability by the State Treasurer has likewise not been utilized.

Ms. Luce has been utilizing both the e-mail address and physical location of the LARWQCB as her work address. The utilization of the addresses has led to common belief that Ms. Luce is a Water Board employee. It is unknown but possible at this time to believe that the utilization of the addresses created a belief that Ms. Luce is LARWQCB personnel, which has in turn, provided Ms. Luce with access to controlling positions on various committees such as IRWMP (Integrated Resource Water Management Program). It would seem that by creating, via continued use of LARWQCB email address and business address, a very public belief that Ms. Luce is a Water Board employee may constitute impersonating a Water Board employee. The following is an e-mail exchange between Ms. Luce and a person with long associations with the Water Board and has acted as a contractor in Ballona restoration matters.

*'Travis Longcore [travislongcore@laaudubon.org](mailto:travislongcore@laaudubon.org) wrote:*

*Bounced from your waterboards address. Are you no longer a Water Board employee? –*

*Travis*

*On Sep 19, 2011, at 2:29 PM, Shelley Luce wrote:*

***No, not for many years.** Most of our staff are with our SMBR Foundation. I will check my calendar and get back to you on this meeting, thank you for the invitation.*

*Shelley” (emphasis added)*

Ms. Luce does not appear to answer directly about herself with regard to the Foundation, or what she means by “our SMBR Foundation”. She also does not explain her past personal use of the LARWQCB addresses while not employed and why she suddenly discontinued the practice.

Ms. Luce’s resume cites her experience prior to SMBRC Commission / Foundation as having been employed by Heal the Bay- the organization that has become institutionalized as part of the SMBRC. Our research indicates Ms. Luce was working in some capacity at LARWQCB during the years 1999-2001- prior to her finishing degrees from UCLA. It appears that her continued use of the Water Board e-mail address after no longer providing service to the California Water Resources Control Board has led/misled many people. ( A PRA to LARWQCB is pending for identification of duties.)

**Coastal Conservancy- PRA Response to J. Davis**

---

**Rare ecosystems of the coastal marsh area are discussed internally by the SAC team with the CC project manager and staff of the Foundation; the information**

**is not broadcasted for public awareness, inclusion of discussion and decision making as promised.**

*"Rich noted that the discussion of grasslands should include mention of the historical native grassland prairie ecosystems that previously existed in the area. The rarity of native grasslands should be discussed,,," (CD- 6/28/08 SAC Conference Call)*

*"Rarity section...complex of prairie and vernal pool...  
Wet grasslands formed extensive areas were also palustrine wetlands above highest high tide.." (CD- SAC Call 6/23/08)*

*"...there is native biodiversity in the non-tidal saline soils. .... At Ballona, these wetlands at Area A, for example, are the only habitat where Alkali Barley (*Hordeum depressum*) is known to occur in the Ballona Ecosystem. This annual grass was probably the dominant native annual grass in naturally occurring non-tidal saline soils at Ballona." (CD- 11/23/08, Wayne Ferren communication to Mary Small...)*

And,

*"The region has a shortage of mudflat for shorebirds, high marsh for animals and salt marsh bird's beak, marsh-upland transition for rare shrubs (eg. , box thorn) that are used by animals,...*

*The region has a shortage of dune habitat and back – dune depressions that support clean-water brackish marsh for aquatic plants and animals.*

*One could also list maritime scrub, which remains in several places "...  
( CD- Joy Zedler (SAC) correspondence)*

Thus , without public /Working Group inclusion and input into the formation of the alternatives and later failure to include the public /Working Group comments and concerns regarding the PWA Alternatives that are presented at one public meeting--the CC and Foundation staff continue to work behind publically closed doors to focus upon the 'Preferred Alternative", now known as Alternative 5 presented in the 1/19/12, Staff Recommendation request for funding. Alternative 5 requires massive, non-historic, extraordinary, experimental and knowingly toxic changes to occur on the land masses of Area A and B so that **"biodiversity = highest richness of estuarine dependent species."**

**Contrary to the 8/13/04 CC Memo which promised transparency and public inclusion in the alternative planning process** which would "restore and enhance" a mix of wetland habitats....and that would implement a technically feasible, cost effective, ecologically beneficial and sustainable restoration.  
Instead, the public was shut out of the planning process; and SAC knowledge regarding the **needs and dangers posed by Alternative 5 are not made public:**

*"This alternative makes the greatest change to the site, would be the hardest to reverse and consequently has the most risk." (CD- 9/12/08 MEMO from SAC to PMT )*

*" ..this alternative would **require reliance on upstream flood control and pollutant removal**, and could necessitate periodic removal of accumulated pollutants for some portions of the restored wetlands. Furthermore, it is unknown how the flow and sediment yield from the upper watershed would affect the sustainability of the marsh in terms of scour or sediment deposition." CD, P. 4 of 9, 10/15/08 SAC MEMO, emphasis added.*

There is no evidence of any such large scale BMP (Best Management Practice) planning or proposals for "flood control and pollutant removal" occurring upstream on Ballona Creek.

And,

*"Eric suggested that there be a statement up front indicating that this site will not be self-sustainable, but will need to be actively managed in perpetuity. " ( CD- 7/7/08 SAC Conference Call)*

Discussion and comments made from key federal agencies were withheld from the public, including but not limited to **NOAA communications regarding concern of toxicity of Ballona Creek upon the remaining wetlands should the levy removal and dredging take place.** (CD- National Oceanic Atmospheric Association email)

Studies that discuss the toxicity of the Ballona Creek waters and sediment to life in the waters and sediment were not released or shared with the public:

*"These sediments were toxic to aquatic organisms, potentially from organic compounds in these sediments. Ballona Creek has been identified as a potential source of tidal flows into Areas A, B, and C in each of the proposed restoration alternatives. Therefore, there is concern to tidal marsh areas, resulting in a negative impact to the habitats and biological resources." (CD- Weston -Technical Memorandum 11/26/07; Water Quality Data Gap Investigation Ballona Wetlands Restoration Project- Pohl , P.E., Ph.D.)*

And,

*" The July 2006 report by Weston also concludes that there are concerns related to water and sediment quality adjacent to the tidal channels. Consequently there is a need to develop a strategy to evaluation the potential ecological risk associated with influent water or sediment quality to the restored wetlands.*

*The scientific questions regarding sediment and water quality cannot be answered based on the information currently available, and will ultimately depend on the design of the project." (CD- Memorandum 3/8/08; Subject:*



APPROACH FOR ADDRESSING SEDIMENT AND WATER QUALITY ISSUES)

And;

*“Eric- Conc(ept) D—is it attempt to move water and sediment into system*

*Wayne- breaching levee bringing trash, water pollution and sediment into entire area is problematic.*

*John Dixon-important to describe these NOT as projects, but a directions.*

*Ambrose- maybe D is too extreme—this won’t happen anyway.*

*Dixon- do feasible maximum tidal, not D—need to scale back*

*Jeremy- may need to do that, take out realignment Ballona—include realign on Hydrologic options”*

*(CD-10/30/06 SAC Conference Call)*

**Additional -SPECIFICS OF THE STAFF RECOMMENDATION 1/19/12**

The 1/19/12 Staff Recommendation misleads the public and the Governing Board as seen on pg. 3 of 9, paragraph 5-

*“ In order to complete the environmental analysis required under the National Environmental Policy Act and the California Environmental Quality Act **and to apply for permits to implement the project, detailed technical work must be completed.**” (Emphasis added.)*

What is not disclosed to the reader, is an entire change of process from the Congressionally approved 2005 Joint EIR/EIS process requirements.

The Staff Recommendation sentence itself is also very misleading. The applications for permits to the USACE for implementation of the Coastal Conservancy “Plan”, namely the destruction of the levees and the dredging of Ballona have been in process prior to this Staff Recommendation. The Plan-regarding garnering the USACE permits-including the 408- was already in process. (CD)

The Conservancy in its partnership with SMBRC fails to let the public know that they have been working to end the congressionally approved federal portion of the study which entails a full ecological review of the area between the Westchester Bluffs, the Santa Monica Bay, the Santa Monica mountains to a few miles inland – which would also provide for a full review of ALL REASONABLE ALTERNATIVES for enhancement of the ecosystem. ( See minutes of USACE/Sponsor meetings provided in the 3/28/12 Request to Rescind File No.04-088; EIS Lower Ballona Creek Restoration Feasibility Study 2005)

Undisclosed is the take-over of process for Ballona 'restoration' guided by the Coastal Conservancy that may disengage the USACE analysis provided for in the established 2005 Joint EIR/EIS.

Instead, it appears that the Coastal Conservancy along with SMBRC staff seek to simply garner permits from the USACE ostensibly for destruction of habitat on Ballona, in particular Area A and B of Ballona. Specifically, the CC and SMBRC staff seek permits (eg 408) for levee and land destruction and removal. It appears that the extensive dredging and massive bulldozing may provide the necessary fill for the LA Port. Questions from the public regarding the CC/SMBRC/ USACE status have gone unanswered. (CD docs and SMBRC April meeting -submission by GC )

**Contrary to discussion in the Staff Recommendation**—Area A is vegetated primarily by native plants and native wildlife and, is host to endangered species including but not limited to the Belding's Savannah Sparrow.

Not provided to the public are documents and communications which provide, in part, narrative of 'moving' Belding Savannah Sparrows to areas not planned for dredging. This information is vital for public discussion especially since, destruction of the Belding's habitat may wreak havoc upon the Belding population that utilizes Ballona year round. ( CD)

- Pg. 3 of 9 discusses hydrology/hydraulics studies that need to be done. What is not discussed with the reader are the multiple public requests for actual onsite hydrology studies that would include Ballona aquifer and groundwater studies that would provide the knowledge for alternatives inclusive of groundwater use onsite. Ballona has multiple aquifers underlying the site. The aquifers are classified as potential drinking water sources and are part of the West Basin aquifers which intermingle to the south and east. (Poland Report)
- None of the concerns raised in House Document 389 (part of the USACE review) regarding problems associated with further saltwater intrusion have been discussed. The elimination of the USACE EIS as part of the Joint EIR/EIS would hasten the Coastal Conservancy's and SMBRC staff GOALS = Estuarine which in turn would potentially threaten contamination of the underground aquifers as per House Document 389 literature. None of the above has been made a part of any review despite repeated requests from the public for such studies.
- The SOCALGAS operations and oilfield gas migration throughout the Ballona area have also not been discussed despite repeated requests from the public.
- Thus pg 9 of 9 is insufficient and incorrect in its comments regarding the Local Coastal Program and the Coastal Act, including but not limited to the

fact that there is no LCP language that states Ballona requires action as the Staff Recommendation implies as per 31252.

- 
- Staff Recommendation- Pg. 8 of 9 Under “Sea level rise vulnerability”
- The Staff fail to alert the reader that the ‘broad areas of mid marsh and high marsh’ depicted--showing a meandering Ballona Creek mid-way between Area A and B-- will be inundated with yearly flood waters of the contaminated Ballona Creek –potentially killing nesting or burrowing life in the low, mid and high marsh areas. Concerns by the SAC team regarding scouring, trash and contamination were not disclosed in the Staff Report and have not been shared with the public.
- The Staff fail to inform the reader that the Preferred Plan creates a non historic cycling of yearly floods, debris and contamination as part of an end of pipe solution, a treatment wetland device .
- The Staff Recommendation does not disclose the SAC discussion of concerns regarding the creation of a treatment wetland.
- The Staff Recommendation does not alert the reader as to what is achieved with the use of the bond funds via “hydraulics” information. Will the hydraulics information be exclusive to new levy construction?
- The Staff Recommendation does not disclose to the reader, the need for upcreek flood control or contamination control as is discussed by SAC.
- 

**31400- The Staff Recommendation cites enhancement of future NEW trails.**

The Coastal Conservancy has already awarded large grants specifically for the Ballona Bike Trail (File No. 07-058-01) which, currently exists and is heavily utilized by the public. Since, much public funding has already been utilized and will be utilized further for the pathway, why should that same importance of pathway be taken away at Ballona?

Removal of the levies would not only take away a heavily utilized public biking and hiking trail but would also take away the pathway’s use as an observatory promenade for viewing the interior of Ballona. The levees provide an important opportunity for viewing without intruding.

The Coastal Conservancy and other agencies have failed to embrace and include the public on this issue as well. Using the public’s hard earned money while keeping the public out of the planning process reveals the Coastal Conservancy has not acted in good faith.

**Grant Award of \$280,000 to Mountains Recreation and Conservation Authority (MRCA) File No. 04-088 from Staff Recommendation 7/21/10.**

1. The Mountains Recreation and Conservation Authority governing board refused to approve the use of bond money for the trailhead(s) and other enhancement s at Ballona. The Board agreed with members of the public. Namely, that due to the ongoing **Joint EIR/EIS** process’ requirements being

more stringent than a singular EIR; those added requirements had to be fulfilled prior to any further decision making taking place.

Mr. Edmiston, at the meeting, asked did they want him to return the money?-

**Ostensibly the bond money had already been approved and given to MRCA. Where did the money go? And;**

2. The 1/19/12 Staff Recommendation cites NEW levy demolition and bike trails ,  
“the proposed project could provide a new segment of the Coastal Trail. ....the project is located at the intersection of the California Coastal Trail and the Ballona Creek Trail, and may offer a significant opportunity for the development of improved connections between these trails.” P. 7 of 9 .
  - Since the Coastal Conservancy has been intent upon levee removal of Ballona Creek and dredging the land in the near future; why did the Conservancy give bond money to MRCA for trail head construction and enhancements for Area A (in particular)--apparently an area it intends to soon demolish and dredge? These inconsistencies appear to show misuse of public funds; paying for contractors and salaries for projects that lead nowhere.
  - Furthermore, it appears that when the CC Project Manager of Ballona desires to garner public bond money; the wetlands (or bike path) are discussed in a decidedly positive depiction as below:

*“Despite the degradation of site resources, significant wetland habitat remains within the Ballona Wetlands. Plant species within the project site include wetland indicators such as pickleweed, marsh heather, saltgrass, arrowgrass and glasswort, and a variety of upland and exotic species including brome, iceplant, oxalis, and ryegrass. Bird surveys indicate that the site is used seasonally by a variety of migratory shorebirds, as well as by typical shoreline residents (gulls, terns, and ducks) and typical upland birds including small raptors. Bird species of special interest observed in the project area include nesting pairs of Belding’s Savannah sparrow and foraging use by California least terns. The proposed project will be implemented primarily on the portion of the BWER north of the Ballona Creek channel (Exhibit 2). This area of the reserve currently has very limited public access and suffers from illegal uses. The proposed project seeks to improve the resources on the site, increasing public use while discouraging illegal activities through improvements to fencing and signage.” File No. 04-088*

This same project manager provides an entirely different depiction in the negative—when public bond money is requested for demolition purposes on the same piece of property. Note also the language of utilizing funds to safeguard the property directly contradicts the 1/19/12 Staff Recommendation of the 6 plus million wherein the Project Manager cites the need to demolish and dredge the same area as a means of eliminating public use by the homeless instead of—the aforementioned request for money to protect the same area. ( See also Ms. Small e-mails discussing need to show greater degradation in order to secure the desired outcome. (J. Davis 3/28/12 Request to CC ))  
It appears that the Ballona habitat is characterized dependent upon financial requests--- not on reality or science based requests.

- Despite repeated requests for public follow up with regard to the bond money and that project, (including a request made for information at the recent Ballona Watershed Task Force Meeting) none has been forthcoming from MRCA staff or CC staff.

*"In 2008, the Conservancy authorized funds to the MRCA for planning, final design and implementation of specific public access improvements identified in the Ballona Wetlands Early BALLONA WETLANDS PUBLIC ACCESS IMPROVEMENTS Action Plan. MRCA has completed much of that work and as a result of that planning effort, the project partners determined that some of the specific access improvements identified in that plan may need to be re-evaluated and others should be reviewed and permitted as part of the larger wetland restoration project. Rather than pursue the Early Action Plan improvements, the project partners decided that it is a higher priority to develop targeted educational and public access programs in the northern 300 acre portion of the site where there is currently almost no public access. The proposed project would also provide funding for MRCA to continue working on planning public access improvements for inclusion in the ultimate restoration project."*

**This inconsistency for request/approval and follow-up on bond funds continues to remain unexplained.**

And, how does removal of the levees- the lower leg of the "Class 1 bike path" fit with the public's money expended below?:

*"In 2000, the Conservancy helped fund a regional plan for creation of a "Park to Playa" river parkway from the Baldwin Hills to Marina Del Rey. The plan envisioned creation of a parkway along Ballona Creek to link expanded parks at the Baldwin Hills to the beaches and the Coastal Trail. In 2001, the Conservancy helped fund the Ballona Creek and Trail Focused Special Study which identified potential improvements to the creek and trail. Consistent with that study, the Conservancy has also provided funding for the construction of a pedestrian bridge in Culver City which increased access to the Ballona Creek Trail. That project has been completed. This project will help to implement the vision of the "Park to Playa" and the Focused Study, developing a multi-benefit gateway park that will increase access to the trail and enhance the experience of trail users. File No. 07-058-01; Project Manager Mary Small*

*Conservancy funds for this project are expected to derive from the Conservancy's FY2002/03 appropriation from Proposition 40")*

3. Staff Recommendation pg. 9 of 9 re: Consistency With Local Coastal Policies fails to provide accurate Local Coastal Plan (LCP )background information.

The Coastal Commission certified the first LUP in 1984, the La Ballona MDR Land Use

Plan.

The Land Use Plan was then changed to reflect two distinctly different Land Use Plans, the La Ballona Plan and the new and different MDR LUP.

It is questionable as to if the California Coastal Commission certified another Land Use Plan for the Playa Vista Project.

Consistency with the California Coastal Act must be consistent with Chapter 3 of that Act.

The Project will not restore, but will instead convert the land from one historic natural function to an entirely new function that is unnatural. Lack of saltwater connection is demonstrated in historic maps from the U.S. Geological Survey. ( A USGS map was submitted at the public hearing on Jan 19,2012. The CC remains nonresponsive)

Grassroots Coalition respectfully requests a written response to this Additional Complaint and maintains its request for response to the 3/29/12 REQUEST TO RESCIND APPLICATION FOR STAFF RECOMMENDATION APPROVAL ON 1/19/12, to award \$6,490,000 Ballona Wetlands Restoration Engineering and Technical Studies. (File 04-088)

The PRA response CD cited herein, is on file with the Coastal Conservancy. Copies of the CD are available upon request and/or are being forwarded.

GC also reserves its right to amend this Complaint and Request with additional information.

Attached is the 3/28/12 Request to Rescind from John Davis to Ca.Coastal Conservancy regarding File No. 04-088

Respectfully,  
Patricia McPherson, Grassroots Coalition-President

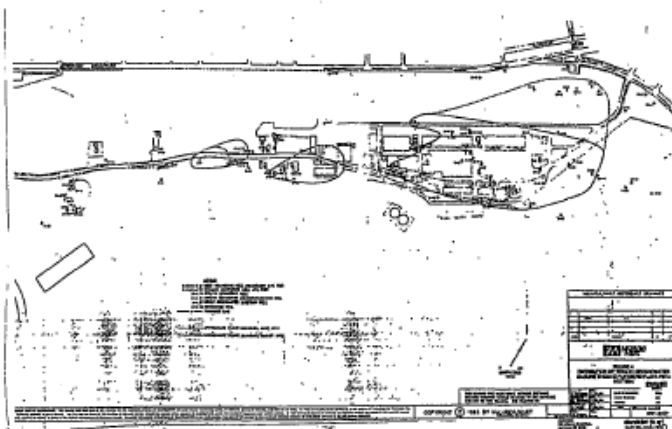
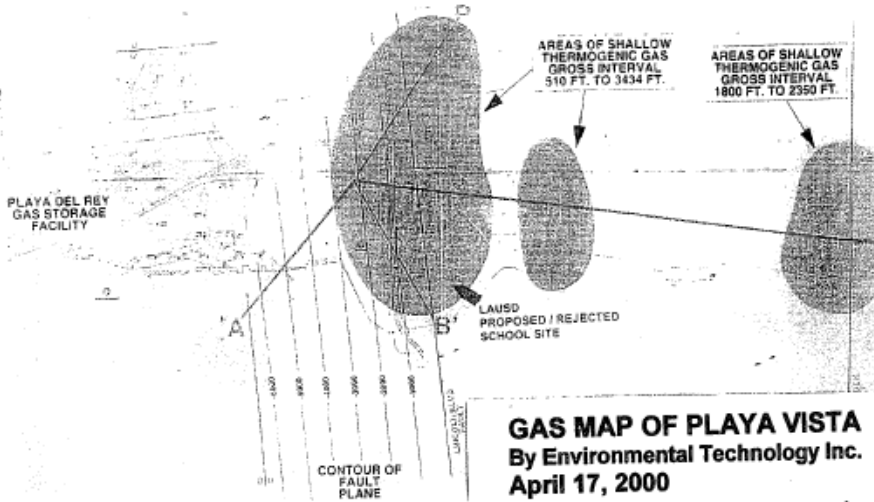

See City Wide Methane Map

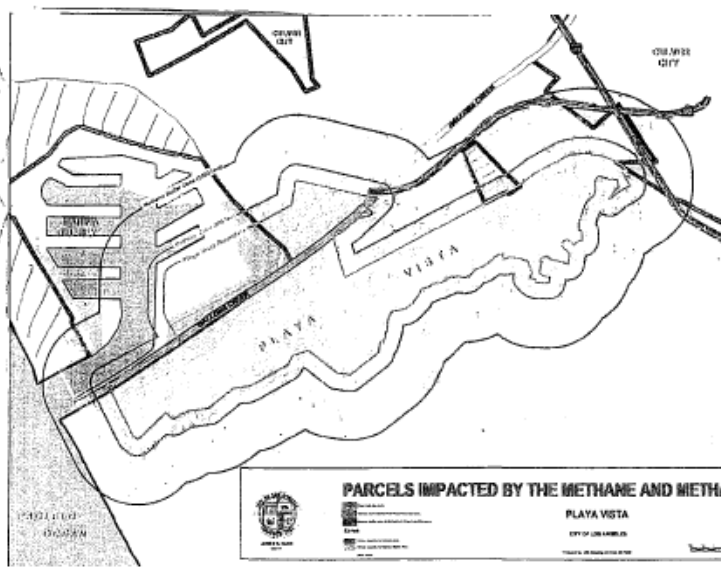

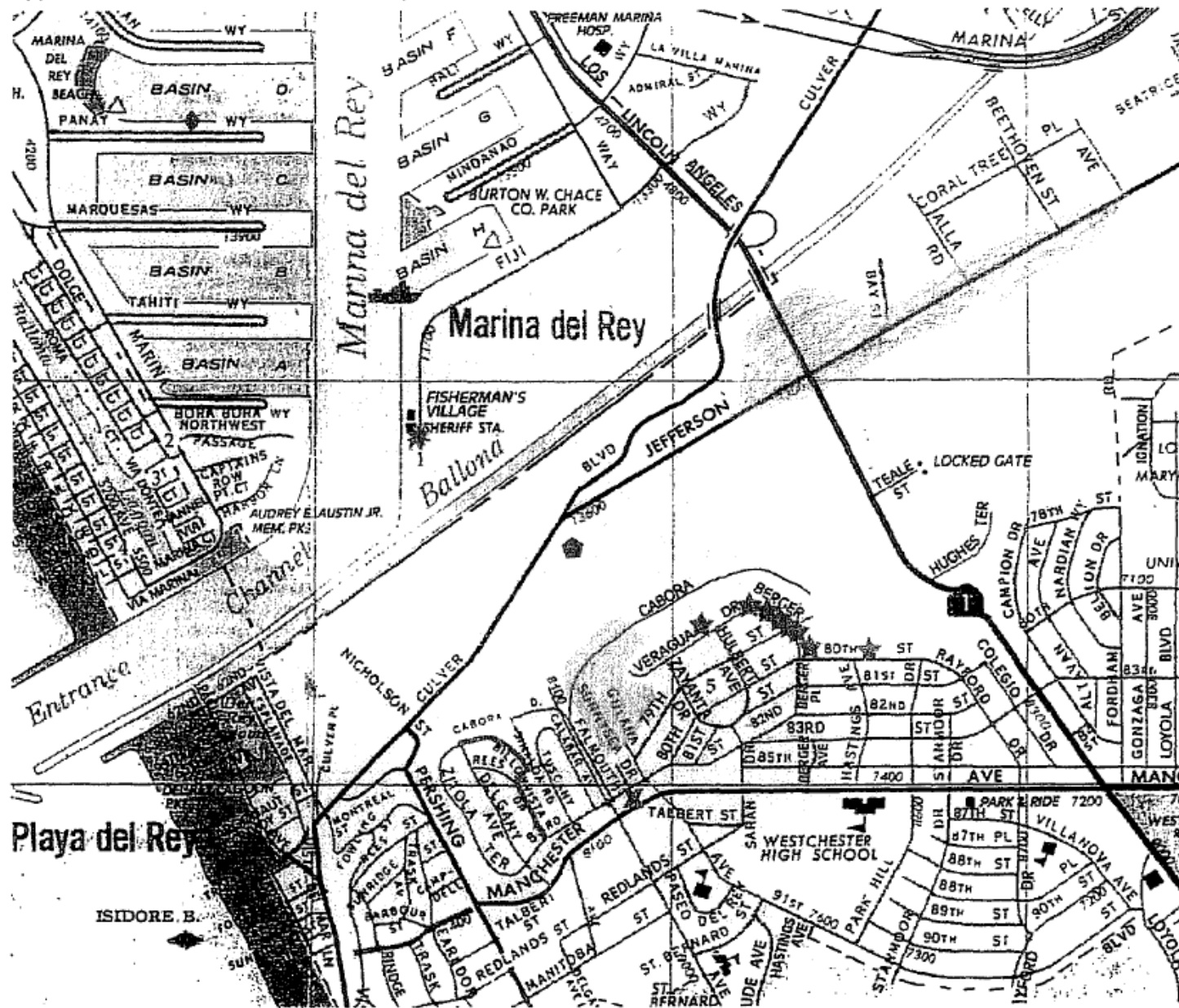

**Source: The California Public Utilities Commission – Safety Branch Investigation**

Playa del Rey 851 Application and Complaint Case  
 Approximate Locations of Facilities and Complaints



**Legend**

-  SCG Facility
-  Gas Storage
-  Playa Vista

- ★ Odor, health and cancer complaints as a result of emissions from the gas facility
- ◆ H<sub>2</sub>S cloud exposure, health complaint
- ✱ Cancer, health complaints as a result of emissions from a well
- ✕ Subsidence complaint
- ⬢ Odor, respiratory complaints from emissions in the wetlands
- ⬢ Reported cancer cluster on Billowvista

**Problematic wells**

- 1 Playa del Rey 18
- 2 Townsite 2
- 3 Townsite 3
- 4 Block 11
- 5 Big Ben 1

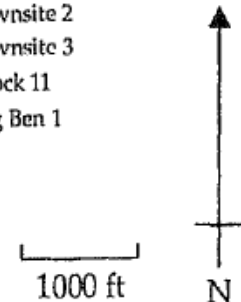

SOURCE: Automobile Club of Southern California 1997 and  MFA Environmental Consulting, Inc.



**California Coastal Conservancy Public Meeting 1/19/2012  
Comments Item 5.**

The project must be denied because its primary premise is a fallacy.

This body is not entitled to provide over Six Million dollars to promote a project promoting a primary premise that is not supported by fact but only creative narrative.

The people expect more. We demand supportive facts.

The factually unsupported premise which is not supported by evidence in this Staff Report as stated on page 3 proposes to "restore" an "ecosystem" "by reconnecting the site to the ocean and creek.

Reconnection of the site to the ocean is a demonstrable fallacy.

The truth as supported by factual government surveys is presented by the United States Geological Survey and the State of California Director of Public Works in a map prepared prior to the construction of Marina del Rey, a Federal Project.

The USGS and the State present proof that the ocean did not connect to the site. This is demonstrable fact.

The USGS Beverly Hills Quadrangle Map produced in 1954 demonstrates no connection of the site to the ocean whatsoever, only a creek to ocean connection.

This is simple to determine by looking at the map before you and you may view the original copy, which is here. ATTACHMENT 1

Either Staff is wrong in its narrative unsupported by fact, or the U.S. Geological Survey and State of California Director of Public Works are wrong.

The Staff Report contains no facts to support its contention that the site was connected to the ocean.

The Federal map does provide clear evidence Staff is wrong.

The Staff Report contention is only supported narrative, which under the CEQA Public Resource Code is not to be considered as legal evidence.

The Government Map was clearly based on factual surveys of the land.

The Staff Report premise is FALSE. The site was never connected to the ocean. Only the Lagoon was connected prior to the installation of tide gates when the creek was channelized. The Lagoon is still subject to tidal flows.

Plases request Staff to respond with facts that demonstrate the State and Federal Government were wrong or deny the permit in absence of this necessary evidence.

The completion of Marina del Rey Harbor allowed for more salt water to into the marshlands that at any prior point in historical times, yet this fact is ignored by Staff.

U.S. Public Law 780 Governs the land. ATTACHMENT 2

U.S. House of Representatives Document 389 on page 4 states that some materials will from the harbor construction will be placed to replenish the local beaches. Page 6 describes widening and improving beaches. Page 10 states, "The project is an integral part of the general plan for development of the shoreline of Santa Monica Bay. The General Plan of Improvement is shown as the last page. It to demonstrates no connection of the ocean to the site. ATTACHMENT 3

Staff ignores the federal interest entirely and the fact that dredge spoils were placed on local beaches, not only on lowlands.

Staff failed to conduct a through investigation backed by fact and has ignored the federal interest in the land which is preemptive under the U.S. Constitution Supremacy Clause.

John Davis  
PO 10152  
Marina del rey Ca. 90295

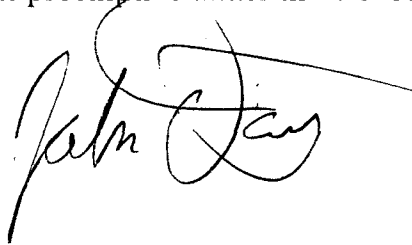
A handwritten signature in black ink, appearing to read "John Davis", is written over the typed name and address.

**ATTACHMENT 1**

UNITED STATES  
DEPARTMENT OF THE INTERIOR  
GEOLOGICAL SURVEY

STATE OF CALIFORNIA  
DIRECTOR OF PUBLIC WORKS

119730  
3470730

1:850,000 FEET (1:263,168 METERS)

PLATE NO. 1



119730  
3470730

60-26

OP - 01

LOS ANGELES COUNTY  
BOARD OF SUPERVISORS

BEVERLY HILLS QUADRANGLE  
CALIFORNIA LOS ANGELES CO.  
7.5 MINUTE SERIES (TOPOGRAPHIC)  
SHEET 60-26

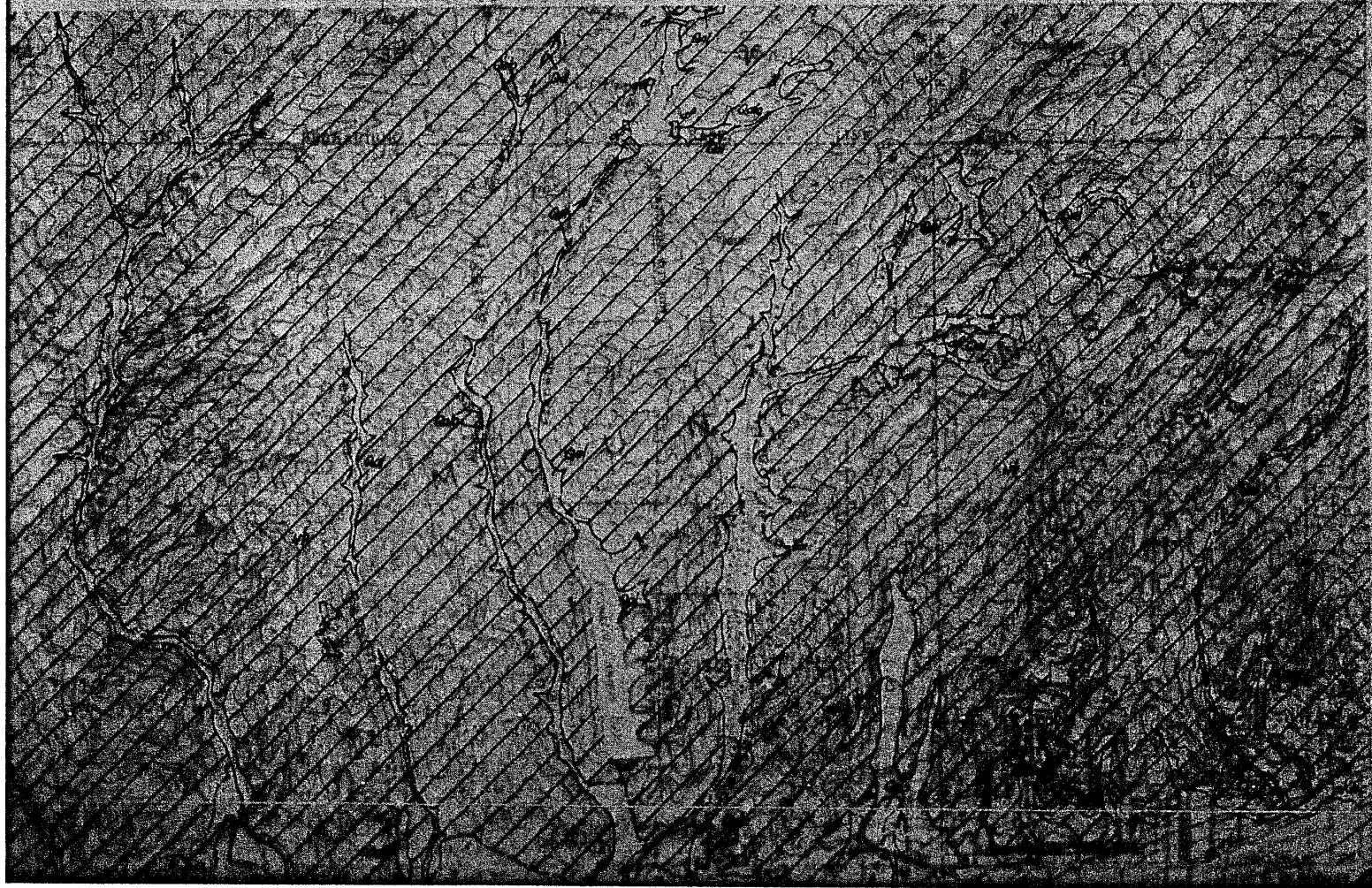

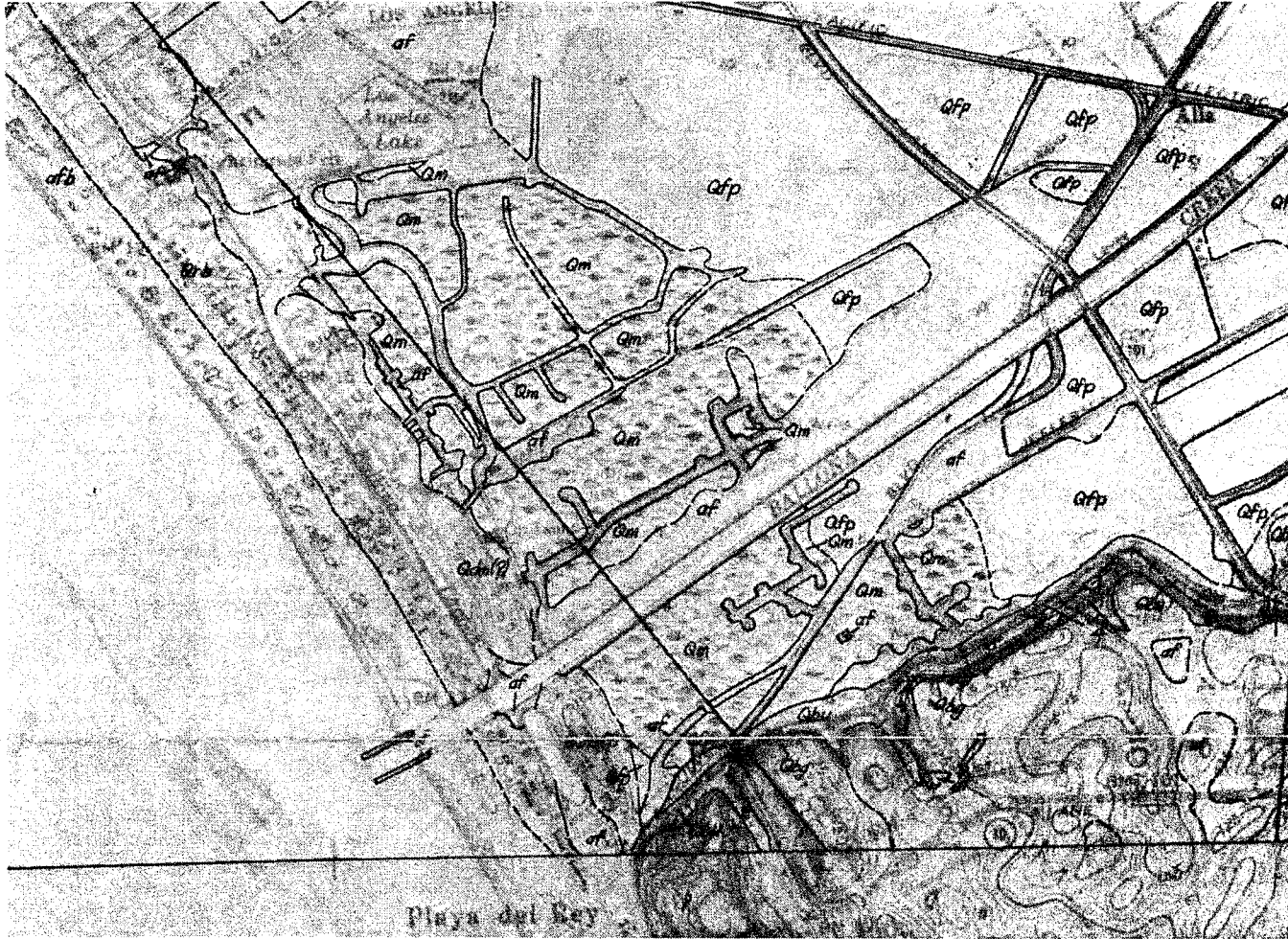

**ATTACHMENT 2**

Interest on judgments.

SEC. 57. The last sentence of subsection (b) of section 2516 of Title 28, United States Code, is amended by inserting immediately after the word "allowed" where it appears in such sentence the words "for any period", so that such subsection will read as follows:

"(b) Interest on judgments against the United States affirmed by the Supreme Court after review on petition of the United States shall be paid at the rate of four percent per annum from the date of the filing of the transcript of the judgment in the Treasury Department to the date of the mandate of affirmance. Such interest shall not be allowed for any period after the term of the Supreme Court at which the judgment was affirmed."

Fees.

SEC. 58. Subsection (a) of section 2520 of Title 28, United States Code, is amended by striking out where it appears in such subsection the words "and the hearing of any case before the court, a judge, or a commissioner", so that such subsection will read as follows:

"(a) The Court of Claims shall by rules impose a fee not exceeding \$10, for the filing of any petition."

SEC. 59. (a) Chapter 165 of Title 28, United States Code, is amended by adding at the end thereof a new section to be designated as section 2521 entitled "Subpoenas" and to read as follows:

"§ 2521. Subpoenas

"Subpoenas requiring the attendance of parties or witnesses and subpoenas requiring the production of books, papers, documents or tangible things by any party or witness having custody or control thereof, may be issued for purposes of discovery or for use of the things produced as evidence in accordance with the rules and orders of the court. Such subpoenas shall be issued and served and compliance therewith shall be compelled as provided in the rules and orders of the court."

(b) The analysis to chapter 165 of Title 28, United States Code, immediately preceding section 2501 of such title, is amended by adding at the end thereof a new item 2521 to read as follows:

"2521. Subpoenas."

Approved September 3, 1954.

Public Law 780

CHAPTER 1264

AN ACT

September 3, 1954  
[H. R. 9859]

Authorizing the construction, repair, and preservation of certain public works on rivers and harbors for navigation, flood control, and for other purposes.

*Be it enacted by the Senate and House of Representatives of the United States of America in Congress assembled,*

River and Harbor  
Act of 1954.

TITLE I—RIVERS AND HARBORS

SEC. 101. That the following works of improvement of rivers and harbors and other waterways for navigation, flood control, and other purposes are hereby adopted and authorized to be prosecuted under the direction of the Secretary of the Army and supervision of the Chief of Engineers, in accordance with the plans and subject to the conditions recommended by the Chief of Engineers in the respective reports hereinafter designated: *Provided*, That the provisions of section 1 of the River and Harbor Act approved March 2, 1945 (Public, Numbered 14, Seventy-ninth Congress, first session), shall govern with respect to projects authorized in this title; and the procedures therein set forth with respect to plans, proposals, or reports for works of improvement for navigation or flood control and for irrigation and purposes incidental thereto, shall apply as if herein set forth in full:

59 Stat. 10.



Wisconsin.

Cornucopia Harbor, Wisconsin: House Document Numbered 434, Eighty-third Congress, at an estimated cost of \$220,000;

Sheboygan Harbor, Wisconsin: House Document Numbered 554, Eighty-second Congress, at an estimated cost of \$217,200;

Michigan.

Holland Harbor, Michigan: House Document Numbered 282, Eighty-third Congress, at an estimated cost of \$574,400: *Provided*, That local interests will contribute 25 per centum of the cost of dredging Section B, but not to exceed \$45,500, in addition to the local co-operation required by the project document;

Crooked and Indian Rivers, Michigan: House Document Numbered 142, Eighty-second Congress, at an estimated cost of \$225,000:

Saginaw River, Michigan: In accordance with the report of the Chief of Engineers, dated June 7, 1954, at an estimated cost of \$4,496,800;

Ohio.

Toledo Harbor, Ohio: House Document Numbered 620, Eighty-first Congress, at an estimated cost of \$512,000;

Ashtabula Harbor, Ohio: House Document Numbered 486, Eighty-third Congress, at an estimated cost of \$4,900,000;

Pennsylvania.

Erie Harbor, Pennsylvania: House Document Numbered 345, Eighty-third Congress, at an estimated cost of \$174,000;

New York.

Black Rock Channel and Tonawanda Harbor, New York: House Document Numbered 423, Eighty-third Congress, at an estimated cost of \$270,000;

Little River at Cayuga Island, Niagara Falls, New York: House Document Numbered 246, Eighty-third Congress, at an estimated cost of \$36,900;

Oswego Harbor, New York: House Document Numbered 487, Eighty-first Congress, at an estimated cost of \$2,459,000;

California.

Los Angeles and Long Beach Harbors, California: House Document Numbered 161, Eighty-third Congress, at an estimated cost of \$896,500: *Provided*, That the Secretary of the Army is hereby authorized to reimburse local interests for such work as they may have done upon this project prior to July 1, 1953, at actual cost to local interests insofar as the same shall be approved by the Chief of Engineers and found to have been done in accordance with the project hereby adopted: *Provided further*, That such reimbursement shall be subject to appropriations applicable thereto or funds available therefor and shall not take precedence over other pending projects of higher priority for harbor improvement: *And provided further*, That such payments shall not exceed the sum of \$500,000;

Playa del Rey Inlet and Harbor, Venice, California: House Document Numbered 389, Eighty-third Congress: *Provided*, That Federal participation in the provision of entrance jetties, entrance channel, interior channel and central basin recommended in the project report and presently estimated to cost \$7,738,000 shall not exceed 50 per centum of the cost thereof;

Port Hueneme, California: House Document Numbered 362, Eighty-third Congress, at an estimated cost of \$5,437,000;

Richmond Harbor, California: House Document Numbered 395, Eighty-third Congress, at an estimated cost of \$2,086,000;

Oregon.

Rogue River, Harbor at Gold Beach, Oregon: Senate Document Numbered 83, Eighty-third Congress, at an estimated cost of \$3,758,700;

Umpqua Harbor and River, Scholfield River at Reedsport, Oregon: Senate Document Numbered 133, Eighty-first Congress, at an estimated cost of \$41,000;

Tillamook Bay and Bar, Oregon: Senate Document Numbered 128, Eighty-third Congress, at an estimated cost of \$1,500,000;

**ATTACHMENT 3**

PLAYA DEL REY INLET AND BASIN, VENICE, CALIF.

LETTER

FROM

THE SECRETARY OF THE ARMY

TRANSMITTING

A LETTER FROM THE CHIEF OF ENGINEERS, DEPARTMENT OF THE ARMY, DATED AUGUST 8, 1952, SUBMITTING A REPORT, TOGETHER WITH ACCOMPANYING PAPERS AND AN ILLUSTRATION, ON A PRELIMINARY EXAMINATION AND SURVEY OF HARBOR AT PLAYA DEL REY, CALIF., AND A REVIEW OF REPORTS ON PLAYA DEL REY INLET AND BASIN, VENICE, CALIF., AS AUTHORIZED BY THE RIVER AND HARBOR ACT APPROVED ON AUGUST 26, 1937, AND REQUESTED BY A RESOLUTION OF THE COMMITTEE ON COMMERCE, UNITED STATES SENATE, ADOPTED ON JUNE 2, 1936

MAY 13, 1954.—Referred to the Committee on Public Works and ordered to be printed, with one illustration

DEPARTMENT OF THE ARMY,  
Washington 25, D. C., May 11, 1954.

The SPEAKER OF THE HOUSE OF REPRESENTATIVES.

DEAR MR. SPEAKER: I am transmitting herewith a report dated August 8, 1952, from the Chief of Engineers, Department of the Army, together with accompanying papers and an illustration, on a preliminary examination and survey of Harbor at Playa del Rey, Calif., and a review of reports on Playa del Rey Inlet and Basin, Venice, Calif., with a view to determining whether any improvement of the locality is warranted at the present time, authorized by the River and Harbor Act approved on August 26, 1937, and requested by a resolution of the Committee on Commerce, United States Senate, adopted on June 2, 1936.

Department of  
Beaches and Harbors

MAY 14 1954

|                            | Init. | Act |
|----------------------------|-------|-----|
| Director                   |       |     |
| Chief of Staff             |       |     |
| Deputy Director            |       |     |
| Executive Assistant        |       |     |
| Admin. Services            |       |     |
| Facilities Management      |       |     |
| Facilities Projects Office |       |     |
| Community Services         |       |     |
| Planning                   |       |     |

REVIEW BY STATE DIVISION OF WATER RESOURCES OF PROPOSED  
REPORT OF THE CHIEF OF ENGINEERS, UNITED STATES ARMY, ON  
PLAYA DEL REY INLET AND BASIN, VENICE, CALIF.

## INTRODUCTION

In accordance with the provisions of section 1 of Public Law 14, 79th Congress, the proposed report of the Chief of Engineers, United States Army, on Playa del Rey Inlet and Basin, Venice, Calif., together with the reports of the Board of Engineers for Rivers and Harbors and of the district and division engineers, was transmitted by the Chief of Engineers on March 31, 1952, to Mr. Frank B. Durkee, director of public works, the official designated by Gov. Earl Warren as his representative in such matters. The report was received and referred to the State engineer on April 7, 1952, for review and report thereon. Thereafter, the reports were transmitted by the State engineer to Seth Gordon, director, department of fish and game; Rufus W. Putnam, executive officer of the State lands commission; Newton B. Drury, chief, division of beaches and parks of the department of natural resources; and G. T. McCoy, State highway engineer.

*Authority for report*

The report was prepared pursuant to a resolution adopted June 2, 1936, which reads as follows:

*Resolved by the Committee on Commerce of the United States Senate, That the Board of Engineers for Rivers and Harbors, created under section 3 of the River and Harbor Act approved June 13, 1902, be, and is hereby, requested to review the reports on Playa Del Rey Inlet and Basin, Venice, California, printed in House Document No. 1880, 64th Congress, 2d session, with a view to determining whether any improvement of the locality is warranted at the present time.*

Further authorization was contained in Public Law 392, 75th Congress, approved August 26, 1937, which reads in part as follows:

SEC. 4. The Secretary of War is hereby authorized and directed to cause preliminary examinations and surveys to be made at the following-named localities, \* \* \* harbor at Playa Del Rey, California \* \* \*.

A review of reports on Playa del Rey Inlet and Basin, Venice, Calif., and preliminary examination of the harbor at Playa del Rey, Calif., dated May 26, 1939, was submitted by the district engineer in accordance with the foregoing authorizations. The district engineer's report was reviewed by the Board of Engineers for Rivers and Harbors, and a report of survey scope was authorized by the Chief of Engineers on April 6, 1944, to determine the advisability and cost of improvement and the local cooperation required.

*Recommendations of the Chief of Engineers*

The following is quoted from the proposed report of the Chief of Engineers now under review:

After full consideration of the reports secured from the district and division engineers, and after affording local interests full opportunity to be heard, the Board recommends provision of a harbor at Playa del Rey, Calif., to consist of 2 entrance jetties each about 2,300 feet long; an entrance channel 20 feet deep, 600 feet wide, and 1,925 feet long; an interior channel 20 feet deep, 600 feet wide, and 5,600 feet long; a central basin 10 feet deep; and 2 side basins 20 feet deep and 10 side basins 10 feet deep, separated by mole-type piers; the dredged material to be utilized for construction of the piers and for deposition on adjacent lowlands and beaches; all generally in accordance with the plan of the district engineer and the comments herein, and with such modifications thereof as in the discretion

B-78

abandoned due to low production and salt-water intrusion, leaving 111 wells on low production.

Local interests consider that the proposed harbor at Playa del Rey would be an integral unit of an adopted general plan for development of the Santa Monica Bay shoreline. This plan includes widening and improving beaches, providing adequate bath houses, parking areas, picnic facilities, special recreation centers, bathing and wading beaches, fishing piers, youth organization camps, tourist parks with cabin and trailer accommodations, and a bird refuge.

*Cost of proposed works*

In the report of the district engineer, the total first cost of the project is given as \$25,603,000, with a Federal first cost of \$9,098,000 and non-Federal first cost of \$16,505,000. The total annual carrying charges would be \$919,920, and the annual benefits would be \$1,529,000. The benefit-cost ratio of the proposed harbor project would be 1.7 to 1.

The Board of Engineers for Rivers and Harbors, in reviewing the report of the district engineer, reevaluated the costs and benefits estimated by the district engineer. In considering both the evaluated and intangible benefits, the Board stated in its report that the Federal interest in the proposed improvement would be served by Federal participation to the extent of providing and maintaining the entrance jetties, entrance channel, interior channel, and central basin shown on the maps accompanying the district engineer's report, all at an estimated first cost of \$6,151,000 for construction exclusive of aids to navigation, and \$25,000 annually for maintenance, with local interests providing and maintaining all other works including dredging of the side basins at an estimated first cost of \$19,427,000.

The Board of Engineers for Rivers and Harbors also reduced the benefits allocated by the district engineer to sport fishing vessels from \$280,000 to \$47,000, making the total annual benefits \$1,296,000. Subsequent to the submission of the report by the district engineer, the United States Coast Guard submitted a revised estimate of \$42,000 for first cost of aids to navigation, an increase of \$17,000, making a total first cost of the project of \$25,620,000. The total annual carrying charges are estimated by the Board to be \$933,025, of which \$277,555 is Federal, and \$655,470 is non-Federal, giving a benefit-cost ratio of 1.4. The recommendation of the Board of Engineers for Rivers and Harbors as to Federal participation is concurred in by the Chief of Engineers.

*Local contributions*

At its meeting on April 25, 1946, the City Council of Los Angeles adopted a report declaring that the public interest and welfare of the city of Los Angeles and vicinity require the provision of additional small craft facilities by means of construction of a small craft harbor at Playa del Rey, assisting the Federal Government in such undertaking by assuming those obligations required under Federal law in connection with the project.

By resolution adopted September 28, 1948, and June 7, 1949, the Board of Supervisors of the County of Los Angeles declared that the public interest and welfare of the county of Los Angeles and its citizens require that provision be made for additional small craft facilities by means of construction of a small craft harbor at Playa del

B-80

*Department of Natural Resources*

Newton B. Drury, chief, Division of Beaches and Parks of the Department of Natural Resources, on June 18, 1952, stated that the thoughts expressed in the comments previously submitted to the district engineer on January 6, 1949 still reflect the reaction of the division to the project.

The comments, submitted by Gen. Warren T. Hannum, director of natural resources, on January 6, 1949, are as follows:

(a) It is found that plan of development as proposed in the district engineer's report would provide a greatly needed harbor for light craft vessels, and as a harbor refuge for such craft cruising along the coast.

(b) That the proposed harbor development is in general in conformity with the county master plan as approved by the State Park Commission.

(c) That there is no State cooperation proposed in the plan, the city of Los Angeles having expressed its desire and willingness to meet the requirements of local cooperation as set forth by the district engineer.

(d) That the incidental benefits to the State park system, due to the deposit of sand on the beaches both upcoast and downcoast from the proposed entrance jetties would be very great.

It is recommended therefore, that the report be approved with a favorable comment indicating the advantages to the State park system from the deposit of sand on the Santa Monica beaches.

## CONCLUSIONS

The following conclusions are submitted with respect to improvements recommended by the Chief of Engineers in his proposed report on Playa del Rey Inlet and Basin, Venice, Calif., giving consideration to (a) need for the project (b) engineering feasibility and effectiveness of the proposed works, and (c) economic justification for the project:

1. The improvements will provide a desirable addition to small-craft facilities along the southern California coast. The project is an integral part of the general plan for development of the shoreline of Santa Monica Bay.

2. Local interest in and approval of the project have been demonstrated by resolution of the city council of the city of Los Angeles, and by resolution of the Board of Supervisors of the County of Los Angeles, giving assurance that the county will assume those non-Federal contributions and obligations in connection with the project which are required by Federal law.

3. The improvements appear to be of sound and adequate design and feasible of construction and operation.

4. Construction of the proposed harbor will introduce ocean water inland a distance of more than 1 mile, and increase the rate of saline contamination of ground waters of the west coast basin. Except in this respect, the proposed works will not conflict with any beneficial consumptive use, present or future, of water for domestic, municipal, stock water, irrigation, mining, or industrial purposes.

## RECOMMENDATIONS

It is recommended that the plan of improvement for the small-craft harbor at Playa del Rey Inlet and Basin, Venice, Calif., as recommended by the Chief of Engineers, be authorized for construction, and that Federal funds be appropriated for the purpose.

SACRAMENTO, CALIF., June 26, 1952.

A. D. EDMONSTON,  
State Engineer.

B-84

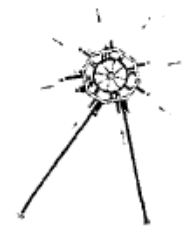
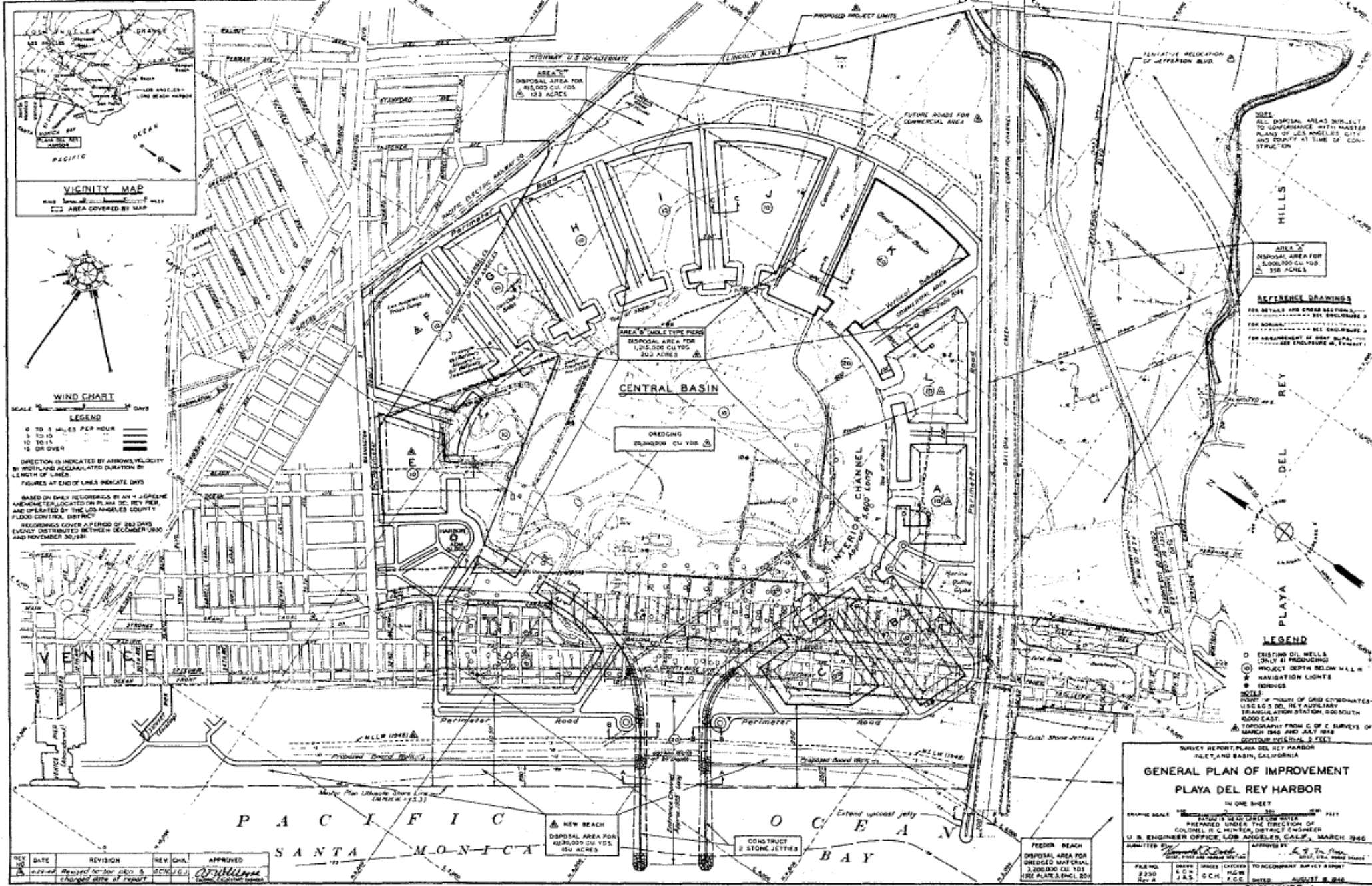

**LEGEND**  
 0 TO 5 MILES PER HOUR  
 5 TO 10  
 10 TO 15  
 15 OR OVER

DIRECTION IS INDICATED BY ARROWS, VELOCITY BY WIDTH, AND ACCUMULATED DURATION BY LENGTH OF LINES.  
 FIGURES AT END OF LINES INDICATE DAYS.

BASED ON DAILY RECORDS BY AN A-GREENE AERONAUTICAL, LOCATED ON PLAYA DEL REY PENINSULA, AND OPERATED BY THE LOS ANGELES COUNTY FLOOD CONTROL DISTRICT.  
 RECORDS COVER A PERIOD OF 363 DAYS, EVENLY DISTRIBUTED BETWEEN DECEMBER 1930 AND NOVEMBER 30, 1931.

NOTE: ALL DISPOSAL AREAS SUBJECT TO CONFORMANCE WITH MASTER PLANS OF LOS ANGELES CITY AND COUNTY AT TIME OF CONSTRUCTION.

AREA 2 DISPOSAL AREA FOR 1,000,000 CU YDS. 158 ACRES

**REFERENCE DRAWINGS**  
 FOR DETAILS AND CROSS SECTIONS SEE ENCL. 1  
 FOR DETAILS SEE ENCL. 2  
 FOR DETAILS OF BEACH IMPROVEMENT SEE ENCL. 3  
 FOR DETAILS OF BEACH IMPROVEMENT SEE ENCL. 4

**LEGEND**  
 ○ EXISTING OIL WELLS ONLY IF DREDGING  
 ⊙ PROJECT DEPTH BELOW M.L.W.  
 \* NAVIGATION LIGHTS  
 ● REMOVED  
 ⊕ POINT OF FIX OF GRID COORDINATES U.S.C. & G.S. DEL. REY AUXILIARY TRIANGULAR STATION, 200 SOUTH 1000 EAST.  
 TOPOGRAPHY FROM C. OF C. SURVEYS OF MARCH 1945 AND JULY 1948.  
 GEOTYPED SECTION 2 FEET

**GENERAL PLAN OF IMPROVEMENT  
 PLAYA DEL REY HARBOR**  
 IN ONE SHEET

GRAPHIC SCALE: 1" = 100' (VERTICAL) 1" = 1000' (HORIZONTAL)

PREPARED UNDER THE DIRECTION OF COLONEL H. C. HUNTER, DISTRICT ENGINEER U. S. ENGINEER OFFICE, LOS ANGELES, CALIF., MARCH 1946

APPROVED BY: [Signature] DATE: AUGUST 8, 1946

ENCLOSURE 1

| REV. | DATE    | REVISION                                     | REV. CHG. | APPROVED    |
|------|---------|----------------------------------------------|-----------|-------------|
| 1    | 12/1/45 | Revised harbor plan & changed date of report | SCM:J.E.  | [Signature] |

USACE Los Angeles District

Att: Secretary of the Army John McHugh  
Att: Col./Commander/District Engineer Mark Toy  
California Department of Fish and Game  
Att: Charlton H. Bonham Executive Director Ca DFG  
Att: The Honorable Congresswoman Maxine Waters  
Att: The Honorable Congresswoman Janice Hahn  
Att: The Honorable Congresswoman Barbara Boxer  
Att: The Honorable Congresswoman Diane Feinstein  
Re: Joint EIS/EIR, Federal Register, July 25, 2012, Ballona Wetlands Project  
From John Davis

Commander Toy, Executive Director Bonham,

Pursuant to the U.S. Environmental Protection Policy and the California Environmental Protection Act, I hereby submit the following comments in regard to the scoping process announced in the respective NOI/NOP.

#### **EXECUTIVE SUMMARY**

My direct concerns are that the project is inconsistent with The U.S. Rivers and Harbors Act(s), U.S. Public Laws 223, 780, and prior Rivers and Harbors Acts. The U.S. Clean Water Act as it relates to Section 303(d) impaired waterway listings, Section 320 National Estuary Program, National Storm Water Pollution Act, CWA provisions protecting sole source aquifers, U.S. Coastal Zone Management Act of 1972, U.S. Environmental Protection Policy, and OMB Circular No. A-16, Coordination of Geographic Information and Related Spatial Data Activities (Draft 6/20/01 edition) which regards the requirement of recordation of Federal Lands by the Bureau of Land Management.

Furthermore, I am concerned about non-compliance with the, California Environmental Quality Act, California Coastal Act, California Water Code, The project threatens the protection of infrastructure and most importantly, human health and safety as it regards geologic hazards, environmental hazards, floods, the rise of sea level, and preservation of potential sources of drinking water from the ground from salt water invasion.

There are land ownership inconsistencies regarding recordation of both local and federal land ownership.

#### **COMMENTS – U.S. PUBLIC LAWS 223 AND 780**

After extensive flooding within the County of Los Angeles caused an estimated 40 million dollars in damage, the U.S. Army Corp of Engineers undertook various flood control projects in the County. Pursuant to the U.S. Rivers and Harbors Act at least two completed federal projects authorized under the aforesaid act exist in the newly proposed project site. U.S. Public Law 223 governs that Westerly portion of Ballona Creek which



was excavated and channelized pursuant to the Rivers and Harbors Act of 1941 (House Document 838), (HD838) hereafter.

U.S. Public Law 223 reads in part;

*“The Chief of Engineers is also authorized in his discretion, to modify the plan for any dam or other work heretofore or hereafter authorized...”*

U.S. Public Law 780, the U.S. Rivers and Harbors Act governs adjacent lands to the North and South in accordance with the General Plan of Improvement approved by the U.S. Congress, (House Documents 389), (HD389) hereafter.

(HD389) The letter from the Secretary of the Army Letter to the Speaker of the House of Representatives dated May 11, 1954 states in part:

*“The Federal Government completed the Ballona Creek flood-control channel and jetties in 1938. The original random stone jetties at the mouth of the channel were extended by the city of Los Angeles in 1946 and are now about 1.350 feet in length.”*

Therefore, the Federal Flood Control Channel build in 1938, subsequent improvements made thereto pursuant to U.S. Public Law 223, and the improvement authorized pursuant to U.S. Public Law 780, are all subject to changes described by the proposed project.

**Exhibit 1. U.S. Public Law 223, House Document 838**

**Exhibit 2. U.S. Public Law 780, House Document 389, Deed to U.S.**

**Exhibit 3. BLM Letter to John Davis, MDR Deed Not Recorded by BLM**

**Exhibit 4. HD 389 Citations by John Davis**

QUESTION 1: UNDER WHAT CONGRESSIONAL AUTHORIZATION IS THE CHIEF OF ENGINEERS PROPOSING CHANGES TO A PROJECT AUTHORIZED AND COMPLETED IN ACCORDANCE TO U.S. PUBLIC LAWS 223 AND 780?

QUESTION 2: DOES THE SECRETARY OF THE ARMY THROUGH THE CHIEF OF ENGINEERS, DEPARTMENT OF THE ARMY, HAVE A VIEW DETERMINING THE PROPOSED IMPROVEMENT OF THE LOCALITY IS WARRANTED AT THE PRESENT TIME, AS AUTHORIZED BY A RESOLUTION OF THE COMMITTEE ON COMMERCE, UNITED STATES SENATE?

QUESTION 2: IS CONGRESSIONAL AUTHORIZATION REQUIRED TO MODIFY THE EXISTING PROJECT(S) BY FILLING, DREDGING, LEVEE DESTRUCTION, LEVEE BUILDING, BASIN BUILDING, AND CHANGING A SURFACE WATER COURSE AUTHORIZED AND COMPLETED IN ACCORDANCE WITH U.S. PUBLIC LAWS 223 AND 780?

QUESTION 3: CAN THE CHIEF OF ENGINEERS LAWFULLY UNDERTAKE A PROJECT THAT CHANGES THE SCOPE AND PURPOSE OF TWO COMPLETED FEDERAL PROJECTS AUTHORIZED IN ACCORDANCE WITH U.S. PUBLIC LAWS 223 AND 780 WITHOUT ANY CONGRESSIONAL AUTHORITY FOR THAT SPECIFIC PURPOSE?

QUESTION 4: IF THE PREVIOUS QUESTION IS YES, TO WHAT EXTENT AND UNDER WHAT EXACT LAWFUL AUTHORITY CAN THE CHIEF OF ENGINEERS MAKE SUCH CHANGES?

QUESTION 5: CAN AND OR COULD THE DISTRICT ENGINEER LAWFULLY CHANGE THE REQUIREMENT FROM "TERMS REASONABLE AND EQUAL, PER (HD389), TO ONLY EQUAL TO ONLY "EQUAL TO ALL", ENABLING THE COUNTY OF LOS ANGELES TO CHARGE COMMERCIAL RATES CONVERTING A FEDERAL PROJECT TO A COMMERCIAL OCEAN GOING LUXURY YACHT HARBOR AND IF SO UNDER WHAT LEGAL AUTHORITY?

QUESTION 6: CAN AND OR COULD THE DISTRICT ENGINEER LAWFULLY CHANGE THE REQUIREMENT SET FORTH IN (HD389) TO PROVIDE "ALL LANDS EASEMENTS AND RIGHTS OF WAY TO THE UNITED STATES FOREVER AND IN PURSUIT" TO ONLY AN EASEMENT OVER THE MAIN CHANNEL, WHICH HAS NOT YET BEEN RECORDED BY THE U.S. BUREAU OF LAND MANAGEMENT?

QUESTION 7: CAN AND OR COULD THE DISTRICT ENGINEER LAWFULLY CHANGE THE REQUIREMENT SET FORTH IN (HD389) TO PROVIDE A ULTIMATE CAPACITY OF 8,000 SMALL CRAFT IN THE VICINITY OF PLAYA DEL REY AND REDUCE THAT REQUIREMENT TO 4,000 SLIPS OR LESS AND UNDER WHAT AUTHORITY.

QUESTION 8: CAN AND OR COULD THE DISTRICT ENGINEER LAWFULLY CHANGE THE REQUIREMENT SET FORTH IN (HD389) TO PROVIDE ADEQUATE PARKING AREAS?

QUESTION 9: QUESTION 6: CAN AND OR COULD THE DISTRICT ENGINEER LAWFULLY CHANGE THE REQUIREMENT SET FORTH IN (HD389) TO CHANGE BOATER RESERVED PARKING TO COMMERCIAL DEVELOPMENT?

QUESTION 10: WHY PERSONNEL OF THE US ACE LOS ANGELES DISTRICT PLAN WITH STAFF OF AGENCIES OF THE STATE OF CALIFORNIA AND OR PRIVATE INDIVIDUALS TO MAKE CHANGES TO U.S. FEDERAL PROJECTS WITHOUT FIRST SEEK THE REQUIRED AUTHORIZATION OF CONGRESS IN REGARD TO U.S. PUBLIC LAW 223 AND 780, AND PRIOR RIVERS AND HARBORS ACTS?

QUESTION 11: COULD THE CALIFORNIA COASTAL ON NOVEMBER 11, 2011 COMMISSION APPROVE MAJOR CHANGES TO REDUCE THE NUMBER OF BOAT SLIPS AND PARKING REQUIRED BY (HD389) WITHOUT FIRST CONSULTING WITH THE USACE LA DISTRICT OR WITHOUT FIRST SEEKING THE CONGRESS OF THE UNITES STATES PURSUANT TO U.S. PUBLIC LAW 780 AND IF SO UNDER WHAT LAWFUL JURDISCTION?

QUESTION 11: COULD THE CALIFORNIA COASTAL CONSERVANCY APPROVE A PLAN TO MAKE MAJOR CHANGES TO COMPLETED FEDERAL PROJECTS WITHOUT FIRST CONSULTING WITH THE USACE LA DISTRICT AND OR SEEKING THE CONGRESS OF THE UNITES STATES PURSUANT TO U.S. PUBLIC LAW 780 AND IF SO UNDER WHAT LAWFUL JURDISCTION?

QUESTION 12: WHY DID THE USACE LOS ANGELES DISTRICT FAIL TO TRANSMIT THE DEED OF LANDS, EASEMENTS, AND RIGHTS OF WAY PURSUANT TO U.S. PUBLIC LAW 780 (HD389) TO THE BLM FOR RECORDATION.

QUESTION 13. WHEN WILL THE USACE LOS ANGELES DISTRICT TRANSMIT THE DEED OF LANDS, EASEMENTS, AND RIGHTS OF WAY PURSUANT TO U.S. PUBLIC LAW 780 (HD389) TO THE BLM FOR RECORDATION.

QUESTION 14: CAN THE PROJECT AT MARINA DEL REY LAWFULLY EXIST AS A FEDERAL PROJECT WITHOUT THE RECORDATION OF THE DEED OF LANDS, EASEMENTS, AND RIGHTS OF WAY PURSUANT TO U.S. PUBLIC LAW 780 (HD389) TO THE BLM AND IF SO UNDER WHAT AUTHORITY.

QUESTION 15: CAN A USACE POLICY TO ONLY REQUIRE LOCAL INTERESTS TO DEED LESS LANDS, EASEMENTS AND RIGHTS OF WAY THAN REQUIRED UNDER U.S. PUBLIC LAW 780 (HD389) AND IF SO HOW CAN A SUCH A POLICY LAWFULLY REPLACE U.S. PUBLIC LAW 780.

#### **Exhibit 5. Request by Congress**

On September 28<sup>th</sup>, 1994 the U.S. Congressional Committee on Public Works and Transportation, U.S. House of Representatives resolved to request the Secretary of the Army review the of the Chief of Engineers on Playa del Rey Inlet and Basin, Venice, California published as House Document 389, Eighty-third, Second Session to determine whether modifications of the recommendations contained therein are advisable at the present time, in the interest of navigation, hurricane and storm damage reduction, environmental restoration, and other purposes at Marina del Rey Harbor, Los Angeles, California with consideration given to the dredging of contaminated sediments.

In 2005 the USACE LA District complied with the request by Noticing a joint EIS/EIR with the Santa Monica Bay Restoration Commission under NEPA and CEQA that would in part consider flood prevention improvements and a review of (HD389). In 2012 the Secretary of the Army provide letters indicating that process was ongoing and would not be terminated and the LA District Legal indicated no termination of that process was anticipated.

Later, in 2012, USACE Los Angeles District noticed an NOI withdrawing from the 2005 process. The reason stated is that the SMRBC requested withdrawal from the process.

QUESTION 16: THERE IS NO PUBLIC RECORD OF THE SANTA MONICA BAY RESTORATION COMMISSION REQUESTING WITHDRAWAL AT THE STATE LEVEL ACCORDING TO RESPONSES MADE UNDER THE PUBLIC RECORDS ACT SO WHAT EXACT REQUEST FROM SMRBC DID THE WITHDRAWAL NOTICE REFER TO AND WHAT PERSON MADE THAT REQUEST ON BEHALF OF SMRBC AND HOW?

QUESTION 17: DID THE USACE DETERMINE THE ENTITY REQUESTING WITHDRAWAL ON BEHALF OF SMRBC HAD THE LAWFUL AUTHORITY OF THE STATE OF CALIFORNIA VESTED IN IT TO REQUEST WITHDRAWAL AND IF SO HOW WERE THE CREDENTIALS OF THAT ENTITY VERIFIED BY USACE?

QUESTION 18: THE SANTA MONICA BAY RESTORATION COMMISSION DID NOT PROVIDE ANY MONEY OR IN KIND SERVICES APPROVED BY THE USACE AS THE SPONSOR AGREEMENT REQUIRED SO WHEN WILL THE FINAL ACCOUNTING FOR THE SPONSOR BE COMPLETED?

QUESTION 19: NEPA REQUIRES NOTICE OF CURRENT EIS PROCESS BE NOTICED IN SCOPING, BUT THE 2012 NOTICE FOR THIS PROJECT DID NOT REFER TO THE 2005 PROCESS THAT WAS CURRENT WHEN THE NOI FOR THE CURRENT PROCESS WAS NOTICED, SO WHY DID USACE LA DISTRICT FAIL TO STATE THE 2005 EIS WAS CURRENT IN THE 2012 NOTICE OF EIR/EIS?

There is no public record of the Santa Monica Bay Restoration Commission requesting withdrawal at the State level, according to responses to Public Records Requests so why did the Corp state a withdrawal was requested?

Note, in accordance with the State Bagley Keene Act, only the Governing Board of the SMRBC may take action to request withdrawal from the 2005 process

**Exhibit 4. NOI(s) for Joint EIR/EIS 2005, 2012, Withdrawal 2012, Secretary of Army Letters, LA District Letter**

## COMMENTS U.S. CLEAN WATER ACT

The U.S. Clean Water Act lists more than four distinct 303(d) impaired water bodies present. The current proposal is to dredge and fill the Ballona Creek Estuary, an Estuary of National Significance listed by U.S. EPA in accordance with Section 320 of the USCWA National Estuary Program.

The intent of the NEP is to preserve and protect estuaries.

QUESTION 20: WHY DOES THE PROJECT PROPOSE TO DESTROY A LARGE PART OF THE MAPPED AND CLASSIFIED ESTURARY BY DREDGING AND FILLING IT?

There is only one impaired water body that is classified as an estuary by USEPA. The proposed project intends to divert the impaired Ballona Creek Estuary into the impaired Ballona Wetlands, and possibly into the impaired Marina del Rey water body.

QUESTION 21: WHY DOES THE PROPOSED PROJECT CONSIDER DIVERSION OF ONE IMPAIRED WATER BODY INTO OTHER DISTINCTS IMPAIRED WATER BODIES INTRODUCING NEW POLLUTION TO ALREADY IMPAIRED WATER BODIES?

## COMMENTS HYDROLOGY

(HD389) cites on page 8 - 9 the following:

*"2. Partial analyses of water samples obtained in April 1952 from 2 active water wells located within the perimeter of the proposed harbor show 640 and 486 parts per million chloride, respectively. Water samples from 2 other active wells located within 2,000 feet east of the eastern perimeter contained 216 and 284 parts per million respectively.*

*...The district engineer's quoted conclusion No. 2 is likewise believed to be essentially correct concerning the present situation. Saline contamination of ground water in the Playa del Rey area was first noted in wells near the ocean in the 1920s. Coincident with this increased pumping draft in the west coast basin, accompanied by further lowering of the water table below sea level, the saline intrusion progressively moved inland until by 1945 - 1946 the limit of 500 parts per million of chloride contamination was from 1.5 - 2 miles from the ocean in the Playa del Rey area.*

*The proposed harbor overlies and important aquifer known as the "50 foot gravel," so named because the average depths of its base is about 50 feet below the ground surface. In the vicinity of the site of the harbor the top of this aquifer is 40 to 45 feet below the land surface. A study of the logs of 14 wells located within one-half mile of the perimeter of the harbor site indicates the aggregate thickness of all the relatively impervious material*

*contained in the sediments overlying the aquifer to vary from 0 to 16 feet. In general, a large percentage of the impermeable material above the 50-foot gravel occurs near the lands surface.*

*Such dredging will obviously decrease the thickness of the impermeable material lying between the floor of the harbor and the top of the water-bearing zone, thereby decrease the resistance offered to the percolation of sea water into the aquifer.*

*From the foregoing observations, it is believed that the quoted conclusion of the district engineer is contrary to what may be expected if the harbor is constructed and that construction of the harbor would aggravate the present conditions of sea-water intrusion and endanger the water quality of wells located near its perimeter in the following ways:*

- 1. By reducing (though dredging) the thickness of relatively impermeable materials which lie between the surface and the top of the 50-foot gravel aquifer.*
- 2. By increasing the landward slope of the water table and consequently the rate of landward slope of the water table and consequently the rate of landward flow of saline water. This slope would be increased as a result of moving the shoreline inland through construction of the harbor.*
- 3. By decreasing the lateral distance that sea water must travel to reach producing wells.*

It is believed that if this project is pursued, the ruination of water wells in the immediate vicinity of the harbor should be contemplated. However, the present landward sloping water indicates that the threat of ocean water pollution already exists at these wells.

### **Exhibit 8. Poland Hydrology Report**

The Poland Report indicates three aquifers are present at the project location. The report further indicates severe salt water intrusion into the groundwater. Also, the report shows the deep Silverado aquifer extends into the South Basin and the aquifer is in communication with the Ballona aquifer and the Bellflower aquitard.

The Silverado aquifer is the sole source of drinking water for Los Angeles. The State of California designates the Santa Monica Basin as a potential source of drinking water.

**QUESTION: WHY DOES THE PROJECT PROPOSE TO ENGAGE A PROCESS THAT WILL ENCOURAGE SALT WATER INTRUSION INTO THE FRESHWATER AQUIFERS THAT WOULD CONTRIBUTE TO THE RUINATION OF POTENTIAL SOURCES OF DRINKING WATER?**

### **COMMENTS – ONLY ONE PROJECT PURSUED**

### **Exhibit 9. Coastal Conservancy Promotes Only One Alternative**

### **Exhibit 10. CA Fish and Game Agrees with Coastal Conservancy Plan**

QUESTION 22: WHY DID THE COASTAL CONSERVANCY ONLY CONSIDER ONE PLAN AND WHY DID THE CALIFORNIA DEPARTMENT OF FISH AND GAME ADOPT ONLY ONE PROJECT PROPOSAL AND WHY IS THE PROPOSAL BEING IMPLEMENTED BY PSOMAS ON BEHALF OF THE DEPARTMENT OF FISH AND GAME INCLUDING BORING OF THE LAND THROUGH THE AQUIFERS?

### **Exhibit 11. CDM Corporation Playa Vista Document**

This document shows that the Playa Vista Project is extracting ground water from water wells.

### **Exhibit 12. LARWQCB NPDES Inspection Reports**

NPDES Inspection Reports by the Los Angeles Regional Water Quality Control Board show that the Agency failed on a regular basis to inspect Flow Meters for extraction wells at the Playa Vista Facility. As a result of this failure, unknown quantities of State owned groundwater is being extracted and discharged to the surface.

QUESTION 23: HOW DOES THE CONTINUED EXTRACTION OF UNKNOWN QUANTITIES OF GROUNDWATER AFFECT THE RECHARGE OF THE BALLONA WETLANDS WHICH ARE HYDROLOGICALLY DOWN GRADIENT FROM THE EXTRACTION SITE?

### **Exhibit 13. Natural Hazards Present**

The proposed project is located in the Venice Quadrangle Seismic Hazard Zone. It is subject to tsunami, seiche, and subsidence. A gas storage facility is located in the subsurface with no approvals from the California Public Utilities Commission and the project area has flooded in recent history.

QUESTION 24: WHAT MEASURES WILL THE PROJECT TAKE TO AVOID NATURAL DISASTERS AT THE SITE?

### **Exhibit 14. AIS GIS System**

QUESTION 25: WILL THE PROJECT USE THE ACE GIS SYSTEM IF NOT WHY?

### **Exhibit 15: NOAA Report On Marina del Rey**

### **Exhibit 16: Report on Biology and History of Project Site**

John Davis  
PO 10152  
Marina del Rey Ca. 90295

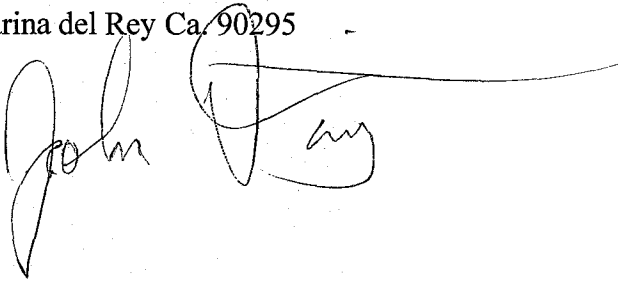
A handwritten signature in black ink, appearing to read "John Davis". The signature is stylized, with the first name "John" written in a cursive script and the last name "Davis" written in a more blocky, cursive style. A long horizontal line extends from the end of the signature to the right.



## **INDEX OF EXHIBITS**

1. U.S. Public Law 223 (House Document 396) ADD ZOOM
2. U.S. Public Law 780 (House Document 389)
3. BLM email to John Davis Re: Land Recordation
4. HD 389 Citations by John Davis
5. Congress Request to the Secretary of the Army.pdf
6. NOI(s) for Joint EIR/EIS/Withdrawal, Letters from Secretary of Army
7. US Clean Water Act 303(d) Impaired Water Bodies Present
8. Poland Hydrology Report
9. Coastal Conservancy Document
10. Fish and Game Document
11. CDM Hydrological Report for Playa Vista
12. LARWQCB NPDES Inspection Reports
13. Natural Hazards Present
14. ACE GIS System
15. NOAA Report on MDR
16. Report on History and Biology of Site

**EXHIBIT 1**

[PUBLIC LAW 228—77TH CONGRESS]

[CHAPTER 377—1ST SESSION]

[H. R. 4911]

AN ACT

Authorizing the construction of certain public works on rivers and harbors for flood control, and for other purposes.

*Be it enacted by the Senate and House of Representatives of the United States of America in Congress assembled, That hereafter Federal investigations and improvements of rivers and other waterways for flood control and allied purposes shall be under the jurisdiction of and shall be prosecuted by the War Department under the direction of the Secretary of War and supervision of the Chief of Engineers, and Federal investigations of watersheds and measures for run-off and waterflow retardation and soil-erosion prevention on watersheds shall be under the jurisdiction of and shall be prosecuted by the Department of Agriculture under the direction of the Secretary of Agriculture, except as otherwise provided by Act of Congress.*

SEC. 2. That section 3 of the Act approved June 22, 1936 (Public, Numbered 738, Seventy-fourth Congress), as amended by section 2 of the Act approved June 28, 1938 (Public, Numbered 761, Seventy-fifth Congress), shall apply to all works authorized in this Act, except that for any channel improvement or channel rectification project provisions (a), (b), and (c) of section 3 of said Act of June 22, 1936, shall apply thereto, and except as otherwise provided by law: *Provided*, That the third proviso of section 1 of the Flood Control Act approved August 28, 1937 (Public, Numbered 406, 75th Congress) and all of section 8 of the Flood Control Act approved August 11, 1939, (Public, Numbered 396, 76th Congress) are hereby repealed: *Provided further*, That the authorization for any flood-control project heretofore or herein adopted requiring local cooperation shall expire five years from the date on which local interests are notified in writing by the War Department of the requirements of local cooperation, unless said interests shall within said time furnish assurances satisfactory to the Secretary of War that the required cooperation will be furnished: *And provided further*, That in any case where the total authorization for a project heretofore or hereafter authorized by Congress is not sufficient to complete plans that may have been made the Chief of Engineers is authorized in his discretion to plan and make expenditures on preparations for the project, such as the purchase of lands, easements, and rights-of-way; readjustments of roads, railroads, and other utilities; removal of towns, cemeteries, and dwellings from reservoir sites; and the construction of foundations. The Chief of Engineers is also authorized in his discretion to modify the plan for any dam or other work heretofore or hereafter authorized so that such dam or work will be smaller than originally planned with a view to completing a

useful improvement within an authorization: *Provided*, That the smaller structure shall be located on the chosen site so that it will be feasible at some future time to enlarge the work in order to permit the full utilization of the site for all purposes of conservation such as flood control, navigation, reclamation, the development of hydroelectric power, and the abatement of pollution.

SEC. 3. That the following works of improvement for the benefit of navigation and the control of destructive floodwaters and other purposes are hereby adopted and authorized in the interest of national security and the stabilization of employment, and shall be prosecuted as speedily as may be consistent with budgetary requirements, under the direction of the Secretary of War and the supervision of the Chief of Engineers in accordance with the plans in the respective reports hereinafter designated and subject to the conditions set forth therein: *Provided*, That penstocks or other similar facilities adapted to possible future use in the development of hydroelectric power shall be installed in any dam herein authorized when approved by the Secretary of War upon the recommendation of the Chief of Engineers and of the Federal Power Commission:

#### CONNECTICUT RIVER BASIN

In addition to previous authorizations, there is hereby authorized to be appropriated the sum of \$6,000,000 for local protection works and \$10,000,000 for reservoirs for the prosecution of the comprehensive plan approved in the Act of June 28, 1938, for the Connecticut River Basin, and such comprehensive plan is hereby modified to include the works recommended by the Chief of Engineers in House Document Numbered 653, Seventy-sixth Congress, third session, and House Document Numbered 724, Seventy-sixth Congress, third session, with such further modifications as may be found justifiable in the discretion of the Secretary of War and the Chief of Engineers.

The Secretary of War is authorized to reimburse the city of Hartford, Connecticut, the sum of \$252,000 heretofore contributed to the United States by said city for the realignment of the South Meadows section of the flood-protection works in accordance with the plans contained in House Document Numbered 653, Seventy-sixth Congress, third session: *Provided*, That there shall be deducted from the aforementioned sum any reimbursement which may be made to said city pursuant to the provisions of section 1 of the War Department Civil Appropriation Act, 1938, approved July 19, 1937.

#### THAMES RIVER BASIN

The plan for a system of reservoirs and channel improvements in the Thames River Basin, Connecticut, Rhode Island, and Massachusetts, in accordance with the recommendation of the Chief of Engineers in House Document Numbered 885, Seventy-sixth Congress, third session, is approved, and there is hereby authorized \$6,000,000 for initiation and partial accomplishment of the project.

#### PAWTUXET RIVER BASIN

The project for local flood protection on the North Branch of Pawtuxet River at Clyde, Rhode Island, and for the Pontiac diver-

sion is hereby authorized to be constructed substantially in accordance with the recommendation of the Chief of Engineers in House Document Numbered 747, Seventy-sixth Congress, third session, at an estimated cost of \$1,320,000.

#### HUDSON RIVER BASIN

The projects adopted by the Act of June 22, 1936, to provide for local flood-protection works in the Hoosic River Basin at North Adams in Massachusetts; at Hoosick Falls, New York, and at Bennington, Vermont, are hereby modified and extended to include the town of Adams, Massachusetts, in accordance with the recommendation of the Chief of Engineers in House Document Numbered 182, Seventy-sixth Congress, first session, and are authorized to be constructed substantially in accordance with said recommendation at an estimated cost of \$2,170,000.

#### LAKE CHAMPLAIN BASIN

The project for local flood protection on the Winooski River at Waterbury, Vermont, is hereby authorized to be constructed substantially in accordance with the recommendation of the Chief of Engineers in House Document Numbered 656, Seventy-sixth Congress, third session, at an estimated cost of \$880,000.

The project adopted by the Act of June 22, 1936, to provide for local flood-protection works on Otter Creek at Rutland, Vermont, is hereby modified in accordance with the recommendation of the Chief of Engineers in Senate Document Numbered 171, Seventy-sixth Congress, third session, and is authorized to be constructed substantially in accordance with said recommendation at an estimated cost of \$308,000.

#### OSWEGO RIVER BASIN

The projects for flood control and other purposes at Canandaigua, Keuka, and Owasco Lakes, and at Hammondsport, Watkins Glen, Montour Falls, Ithaca, and Syracuse, New York, are hereby authorized to be constructed substantially in accordance with the recommendation of the Chief of Engineers in House Document Numbered 846, Seventy-sixth Congress, third session, at an estimated cost of \$3,220,000.

#### BUFFALO RIVER BASIN

The project for local flood protection on Cayuga Creek at Lancaster, New York, is hereby authorized to be constructed substantially in accordance with the recommendation of the Chief of Engineers in House Document Numbered 326, Seventy-seventh Congress, first session, at an estimated cost of \$575,000.

#### SUSQUEHANNA RIVER BASIN

The project adopted by the Act of June 22, 1936, to provide for local flood-protection works on the Susquehanna River at Sunbury, Pennsylvania, is hereby modified in accordance with the recommendation of the Chief of Engineers in House Document Numbered 366, Seventy-sixth Congress, first session, and is authorized

to be constructed substantially in accordance with said recommendation at an estimated cost of \$1,900,000.

The project for flood control in the Susquehanna River Basin in southern New York and eastern Pennsylvania adopted by the Act of June 22, 1936, is hereby modified to include and authorize the construction of the Stillwater Reservoir on the Lackawanna River, Pennsylvania, for flood control and other purposes in accordance with plans now in the Office of the Chief of Engineers at an estimated cost to the United States of \$2,420,000.

#### DELAWARE RIVER BASIN

The project for local flood protection on Rancocas Creek in the vicinity of Mount Holly, New Jersey, is hereby authorized to be constructed substantially in accordance with the recommendation of the Chief of Engineers in House Document Numbered 128, Seventy-seventh Congress, first session, at an estimated cost of \$300,000.

#### NEUSE RIVER BASIN

The project for local flood protection on the Neuse River in the vicinity of Goldsboro, North Carolina, is hereby authorized to be constructed substantially in accordance with the recommendation of the Chief of Engineers in House Document Numbered 327, Seventy-seventh Congress, first session, at an estimated cost of \$40,000.

#### MOBILE RIVER BASIN

The project for local flood protection at Prattville, Alabama, on Autauga Creek, a tributary of the Alabama-Coosa River, is hereby authorized to be constructed substantially in accordance with the recommendation of the Chief of Engineers in House Document Numbered 657, Seventy-sixth Congress, third session, at an estimated cost of \$530,000.

The plan for the Allatoona Reservoir on the Etowah River in the Coosa River Basin, Georgia, for flood control and other purposes in accordance with the recommendation of the Chief of Engineers in House Document Numbered 674, Seventy-sixth Congress, third session, is approved and there is hereby authorized \$3,000,000 for initiation and partial accomplishment of the project.

The project for flood control on the Tombigbee River authorized by the Act of June 22, 1936, is hereby modified to provide for additional channel improvements and related works for flood control for the Tombigbee River and tributaries above the mouth of and including the Noxubee River in accordance with plans approved by the Chief of Engineers at an estimated cost of \$150,000.

#### BAYOU TECHÉ AND VERMILION RIVER

The project for the improvement of Bayou Teche and the Vermilion River, Louisiana, is hereby authorized to be constructed substantially in accordance with the recommendations of the Chief of Engineers in Senate Document Numbered 93, Seventy-seventh Congress, first session, at an estimated cost of \$1,390,000.

**MERMENTAU RIVER BASIN**

The project for the improvement of the Mermentau River in Louisiana for flood control is hereby authorized to be constructed substantially in accordance with the recommendations of the Chief of Engineers in Senate Document Numbered 94, Seventy-seventh Congress, first session, at an estimated cost of \$970,000.

**COLORADO RIVER BASIN (TEXAS)**

The plan for improvement of the Lower Colorado River, Texas, for flood control in accordance with the recommendation of the Chief of Engineers in House Document Numbered 312, Seventy-sixth Congress, first session, is approved and there is hereby authorized \$6,500,000 for the construction of the project.

The plan for San Angelo Reservoir for flood control and other purposes on the North Concho River, Texas, and for local flood-protection works at San Angelo, Texas, in accordance with the recommendation of the Chief of Engineers in House Document Numbered 315, Seventy-sixth Congress, first session, is approved and there is hereby authorized \$2,000,000 for initiation and partial accomplishment of the project.

The plan for Hords Creek Reservoir and for enlargement of the existing Lake Brownwood Reservoir for flood control and other purposes on Pecan Bayou and its tributaries in Texas, in accordance with the recommendation of the Chief of Engineers in House Document Numbered 370, Seventy-sixth Congress, first session, is approved and there is hereby authorized \$1,400,000 for initiation and partial accomplishment of the project, including \$460,000 for the Hords Creek Reservoir.

The project for local flood protection on Brady Creek at Brady, Texas, is hereby authorized to be constructed substantially in accordance with the recommendation of the Chief of Engineers in House Document Numbered 441, Seventy-sixth Congress, first session, at an estimated cost of \$825,000.

**BRAZOS RIVER BASIN**

The plan for Whitney Reservoir on the Brazos River in Texas, for flood control and other purposes in accordance with the recommendation of the Chief of Engineers in House Document Numbered 390, Seventy-sixth Congress, first session, is approved and there is hereby authorized \$5,000,000 for the initiation and partial accomplishment of the project.

**LOWER MISSISSIPPI RIVER**

The project for flood control of the Lower Mississippi River adopted by the Act of May 15, 1928, as amended by the Act of June 15, 1936, as amended by the Acts of August 28, 1937, and June 28, 1938, is hereby modified and, as modified, is hereby authorized and adopted, and the Flood Control Act of June 15, 1936, as amended, is amended as follows:

(a) The existing engineering plan for flood control in the alluvial valley of the Mississippi River is hereby modified so as to provide

for the construction of plan 4 as set forth in the report of the Mississippi River Commission, dated March 7, 1941, to the Chief of Engineers, except that the levees in the Yazoo Basin on the east bank of the Mississippi River south of the Coahoma-Bolivar County line in said plan shall have a three-foot freeboard over the project flood, and all levees shall be constructed with adequate section and foundation to conform to increased levee heights. The Boeuf Floodway in the project adopted by the Act of May 15, 1928, and the Eudora Floodway as well as the Northward Extension and the back protection levee extending from the head of the said Eudora Floodway north to the Arkansas River in the project adopted by the Act of June 15, 1936, as amended, are hereby abandoned, and the provisions of said Acts relating to the prosecution of work on said floodways and extension are hereby repealed.

(b) The project for flood control of the Yazoo River shall be as authorized by the Flood Control Act approved June 15, 1936, as amended by section 2 of the Act approved June 28, 1938, except that the Chief of Engineers may, in his discretion, from time to time, substitute therefor combinations of reservoirs, levees, and channel improvements; and except that the extension of the authorized project and improvements contemplated in plan C of the report of March 7, 1941, of the Mississippi River Commission are authorized, including the extension of the levee on the east bank of the Mississippi River generally along the west bank of the Yazoo River to a connection in the vicinity of Yazoo City with the Yazoo River levee, authorized by the existing project for protection against headwater floods of the Yazoo River system, and the adjustment in the discretion of the Chief of Engineers of the grades of the existing levees in the backwater area on the east bank of Yazoo River below Yazoo City, all at an estimated additional cost of \$11,982,000: *Provided*, That the Chief of Engineers shall fix the grade of the extension levees along the Yazoo River, with higher levees in his discretion, so that their construction will give the maximum practical protection without jeopardizing the safety and integrity of the main Mississippi River levees: *And provided further*, That prior to the beginning of construction local authorities shall furnish satisfactory assurances that they will (1) maintain the levees in accordance with the provisions of section 3 of the Act of May 15, 1928, and will (2) not raise the levees in the backwater above the limiting elevations established therefor by the Chief of Engineers.

(c) In the development of the authorized project, the construction of a levee and improvements contemplated in the report of March 7, 1941, of the Mississippi River Commission from the main-line levee on the west bank of the Mississippi River in the vicinity of Shaw, Louisiana, westward and northward to the vicinity of Newlight, Louisiana, for the protection of that part of the Red River backwater known as the Tensas-Cocodrie area at an estimated cost of \$6,976,000 is hereby authorized: *Provided*, That the Chief of Engineers shall fix the grade of said levee, with a higher levee in his discretion, so that its construction will give the maximum practical protection without jeopardizing the safety and integrity of the main Mississippi River levees: *And provided further*, That prior to the beginning of construction local authorities shall furnish satisfactory assurances that they will (1) maintain the levee in



accordance with the provisions of section 3 of the Act of May 15, 1928, and will (2) not raise the said levees above the limiting elevations established therefor by the Chief of Engineers: *Provided further*, That subject to the foregoing conditions of local cooperation the Chief of Engineers may in his discretion substitute other levees and appurtenant works for, or make such modifications of, the levees and improvements herein authorized for the protection of the Tensas-Cocodrie area as may be found after further investigation to afford protection to a larger area in the Red River Backwater at a total cost not to exceed \$14,000,000 and without jeopardizing the safety and integrity of the main Mississippi River levees and without preventing or jeopardizing the diversions contemplated in the adopted project through the Atchafalaya River and Atchafalaya Basin.

(d) The Chief of Engineers, with approval of the Secretary of War, shall reimburse local authorities for actual expenditures found by the Chief of Engineers to be reasonable, for providing at the request of the United States, in accordance with local legal procedure or custom, rights-of-way and flowage easements required for future setbacks of main-line Mississippi River levees.

(e) The existing engineering plan for flood control of the Saint Francis River is hereby modified so as to permit the substitution for the suspended portions of the original project below Oak Donnick, Arkansas, of the construction of a ditch in Cross County, Arkansas, beginning in the vicinity of the outlet end of the existing Oak Donnick to Saint Francis Bay floodway and terminating in Saint Francis Bay about two miles north of Riverfront, including the construction of a highway bridge at State Highway Numbered 42 made necessary by the ditch construction: *Provided*, That local interests give assurances satisfactory to the Secretary of War that they will (1) provide without cost to the United States all lands, easements, and rights-of-way necessary for the construction; (2) hold and save the United States free from damages due to the construction works; and (3) maintain the works after completion in accordance with regulations prescribed by the Secretary of War.

(f) In the development of the authorized project, the construction of improvements for Bayou Rapides, Boeuf, and Cocodrie, Louisiana, contemplated in the report dated March 24, 1941, of the Special Board of Officers at an estimated cost of \$2,600,000 is hereby authorized.

(g) The total authorizations heretofore made for the flood control project of the alluvial valley of the Mississippi River shall not be increased by reason of any provision in this Act, except for the additional amounts necessary for the Yazoo and Red River backwater improvements, and any appropriations heretofore or hereafter made or authorized for said project as herein or heretofore modified may be expended upon any feature of the said project, notwithstanding any restrictions, limitations, or requirements of existing law: *Provided*, That funds hereafter expended for maintenance shall not be considered as reducing present remaining balances of authorizations.

(h) Any officer of the Corps of Engineers who has served or shall serve four years as President of the Mississippi River Commission

and who has been or shall subsequently be retired, shall, from the date of such retirement, receive the rank, pay, and allowances of a retired major general.

The project for flood control on the Homochitto River in Mississippi, authorized by the Act of June 22, 1936 (Public, Numbered 738, Seventy-fourth Congress), and modified by the Act of June 28, 1938 (Public, Numbered 761, Seventy-fifth Congress), is hereby further modified to provide for additional channel improvements and related works for flood control on the Homochitto River and tributaries in accordance with plans approved by the Chief of Engineers, and for the execution of these plans there is hereby authorized \$50,000.

#### RED-OUACHITA RIVER BASIN

The project for local flood protection on the Ouachita River near Calion, Arkansas, is hereby authorized to be constructed substantially in accordance with the recommendation of the Chief of Engineers in House Document Numbered 427, Seventy-sixth Congress, first session, at an estimated cost of \$50,000.

The project for local protection on the Red River in Grant Parish below Colfax, Louisiana, authorized by the Act approved June 28, 1938, is hereby amended to add and authorize the following: Levee enlargement, new levee extension, and the construction of appurtenant drainage structures on the left bank of the Red River opposite Alexandria for the protection of Pineville, Louisiana, and vicinity, at an estimated cost to the United States of \$159,100, subject to the provisions of section 3 of the Act approved June 22, 1936.

The project for local flood protection on the Red River in Grant Parish below Colfax, Louisiana, authorized by the Act approved June 28, 1938, is hereby further amended to include and to authorize the following: Levees and appurtenant drainage works on the left bank of the Red River and along Bayous Darrow and Rigolette, the improvement of the channel of Bayou Rigolette, and the separation of the channels of Bayous Darrow and Rigolette in the Aloha-Rigolette area, Grant and Rapides Parish, Louisiana, all at an estimated cost to the United States of \$914,500, subject to the provisions of section 3 of the Flood Control Act approved June 22, 1936.

The project for the Bayou Bodcau Reservoir, Louisiana, authorized by the Act of June 22, 1936, as modified by the Acts of June 28, 1938, and June 28, 1939, is hereby further modified to include and to authorize channel improvements below the reservoir on Bayou Bodcau, Red Chute, and Loggy Bayou at an estimated cost of \$198,000, subject to the provisions of Section 3 of the Flood Control Act approved June 22, 1936.

The plan for the Narrows Reservoir for flood control and other purposes on the Little Missouri River, Arkansas, and for local flood protection on the main river below Murfreesboro and on the Terre Noire and Ozan Creeks, substantially in accordance with recommendation of the Chief of Engineers in House Document Numbered 837, Seventy-sixth Congress, third session, is approved and there is hereby authorized \$3,000,000 for initiation and partial accomplishment of the project.

## WHITE RIVER BASIN

In addition to previous authorizations, there is hereby authorized to be appropriated the sum of \$24,000,000 for the prosecution of the comprehensive plan approved in the Act of June 28, 1938, for the White River Basin in Missouri and Arkansas, including the projects for flood control and other purposes recommended by the Chief of Engineers in House Document Numbered 917, Seventy-sixth Congress, third session; and the modifications in the Norfolk Reservoir project recommended by the Chief of Engineers in House Document Numbered 290, Seventy-seventh Congress, first session.

The projects for local flood protection on the White River, on the east side between Augusta and Clarendon, Arkansas, and at the town of De Valls Bluff, Arkansas, are hereby authorized to be constructed substantially in accordance with the recommendation of the Chief of Engineers in House Document Numbered 98, Seventy-sixth Congress, first session, at an estimated cost of \$2,847,500.

## ARKANSAS RIVER BASIN

The general comprehensive plan for flood control and other purposes, approved by the Act of June 28, 1938, for the Arkansas River Basin, is hereby modified to include the reservoirs in the Grand (Neosho) River Basin in Oklahoma and Missouri, and in the Verdigris River Basin in Kansas, in accordance with the recommendations of the Chief of Engineers in House Documents Numbered 107 and 440 of the Seventy-sixth Congress, first session. In addition to previous authorizations, there is hereby authorized to be appropriated the sum of \$29,000,000 for the prosecution of said comprehensive plan.

The project for local flood protection on the Salt Fork of the Arkansas River in the vicinity of Cherokee, Oklahoma, is hereby authorized to be constructed substantially in accordance with the recommendation of the Chief of Engineers in House Document Numbered 450, Seventy-sixth Congress, second session, at an estimated cost of \$800,000.

The project for local flood protection along the south bank of the Arkansas River between Little Rock and Pine Bluff, Arkansas, is hereby authorized to be constructed substantially in accordance with the recommendation of the Chief of Engineers in House Document Numbered 718, Seventy-sixth Congress, third session, at an estimated cost of \$641,000, with such modifications as may be advisable in the discretion of the Secretary of War and the Chief of Engineers.

The project for local flood protection along the north bank of the Arkansas River in the Crawford County Levee District, Arkansas, is hereby authorized to be constructed substantially in accordance with the recommendation of the Chief of Engineers in House Document Numbered 720, Seventy-sixth Congress, third session, at an estimated cost of \$284,000.

The project for local flood protection on both sides of the Arkansas River in the immediate vicinity of Tulsa and West Tulsa, Oklahoma, is hereby authorized to be constructed substantially in accordance with the recommendation of the Chief of Engineers in House Document Numbered 157, Seventy-seventh Congress, first session, at an estimated cost of \$513,000.

## OHIO RIVER BASIN

In addition to previous authorizations, there is hereby authorized to be appropriated the sum of \$45,000,000 for the prosecution of the comprehensive plan approved in the Act of June 28, 1938, for the Ohio River Basin, modified to include the Allegheny Reservoir project in accordance with the recommendation of the Chief of Engineers in House Document Numbered 300, Seventy-sixth Congress, first session.

The project for local flood protection on the Licking River at Salyersville, Kentucky, is hereby authorized to be constructed substantially in accordance with the recommendations of the Chief of Engineers in House Document Numbered 261, Seventy-seventh Congress, first session, at an estimated cost of \$174,000.

## TENNESSEE RIVER BASIN

The projects for local flood protection on the Tennessee River at Chattanooga, Tennessee, and Rossville, Georgia, are hereby authorized to be constructed substantially in accordance with the recommendation of the Chief of Engineers in House Document Numbered 479, Seventy-sixth Congress, second session, at an estimated cost of \$13,500,000.

## UPPER MISSISSIPPI RIVER BASIN

The project adopted by the Act of June 22, 1936, for the Dry Run Reservoir near Decorah, Iowa, is hereby modified to authorize the Chief of Engineers to modify the project so as to provide protection by diversion of floodwaters in accordance with revised plans now on file in his office, at an estimated Federal cost of \$460,000.

## SEBEWAING RIVER

The project for local flood protection on the Sebewaing River in the vicinity of Sebewaing, Michigan, is hereby authorized to be constructed substantially in accordance with the recommendation of the Chief of Engineers in House Document Numbered 286, Seventy-sixth Congress, first session, at an estimated cost of \$250,000.

## MISSOURI RIVER BASIN

In addition to previous authorizations, there is hereby authorized to be appropriated the sum of \$7,000,000 for the prosecution of the comprehensive plan approved in the Act of June 28, 1938, for the Missouri River Basin, including the project for the Harlan County Reservoir on the Republican River, Nebraska, recommended by the Chief of Engineers in House Document Numbered 842, Seventy-sixth Congress, third session, and such other supplemental flood-control works on the Republican River as the Secretary of War and the Chief of Engineers may find advisable.

The comprehensive plan for the improvement of Cherry Creek and tributaries, Colorado, for flood control and other purposes in accordance with the recommendations of the Chief of Engineers in House Document Numbered 426, Seventy-sixth Congress, first session, is approved and there is hereby authorized \$3,000,000 for the initiation and partial accomplishment of the project.

The project for local flood protection on the Platte River in the vicinity of Schuyler, Nebraska, is hereby authorized to be constructed substantially in accordance with the recommendation of the Chief of Engineers in House Document Numbered 250, Seventy-sixth Congress, first session, at an estimated cost of \$63,000.

The project for local flood protection on the Missouri River and Indian Creek at Council Bluffs, Iowa, is hereby authorized to be constructed substantially in accordance with the recommendation of the Chief of Engineers in House Document Numbered 577, Seventy-sixth Congress, third session, at an estimated cost of \$18,000.

The project for the improvement of Fall River and tributaries, South Dakota, for flood control is hereby authorized to be constructed substantially in accordance with the recommendation of the Chief of Engineers in House Document Numbered 655, Seventy-sixth Congress, third session, at an estimated cost of \$1,050,000.

The project for flood protection in the vicinity of Sioux City, Iowa, and along both banks of the Missouri River between Sioux City and Kansas City for flood control in accordance with the recommendation of the Chief of Engineers in House Document Numbered 821, Seventy-sixth Congress, third session, is approved and there is hereby authorized \$1,000,000 for the initiation and partial accomplishment thereof: *Provided*, That such project is hereby modified by eliminating the requirement that the States having a common boundary on the Missouri River shall, as a condition precedent to the initiation of construction along that portion of the river, establish by interstate compact floodway boundary lines and floodway regulations satisfactory to the Secretary of War.

#### SANTA ANA RIVER BASIN

In addition to previous authorizations, there is hereby authorized to be appropriated the sum of \$2,500,000 for the prosecution of the projects approved in the Acts of June 22, 1936, and June 28, 1938, for flood control in the Santa Ana River Basin and for the protection of Orange County in California.

#### LOS ANGELES-SAN GABRIEL RIVER BASIN AND BALLONA CREEK

The general comprehensive plan for flood control and other purposes in the basins of the Los Angeles and San Gabriel Rivers and Ballona Creek as set forth in House Document Numbered 838, Seventy-sixth Congress, third session, is approved, and in addition to previous authorizations there is hereby authorized \$25,000,000 for the partial accomplishment of that plan.

#### SACRAMENTO-SAN JOAQUIN RIVER BASIN

The projects for the control of floods and other purposes in the Sacramento River, California, adopted by the Acts approved March 1, 1917, May 15, 1928, and August 26, 1937, are hereby modified substantially in accordance with the recommendation of the Chief of Engineers in House Document Numbered 205, Seventy-seventh Congress, first session, at an estimated cost of \$10,500,000, and also modified to provide for channel clearing, rectification, snagging, and

bank protection on the Sacramento River and tributaries in Tehama County, and from Red Bluff southerly, at an additional estimated cost of \$150,000.

The project for the Fresno County Stream Group for flood control is hereby authorized to be constructed substantially in accordance with the recommendations of the Chief of Engineers in House Document Numbered 845, Seventy-sixth Congress, third session, at an estimated cost of \$510,000.

#### UMPQUA RIVER BASIN

The project for improvement of the Umpqua River in Oregon for flood control is hereby authorized to be constructed substantially in accordance with the recommendation of the Chief of Engineers in House Document Numbered 684, Seventy-sixth Congress, third session, at an estimated cost of \$176,000.

#### YAQUINA RIVER BASIN

The project for local flood protection on the Yaquina River in the Mill Four District, Oregon, is hereby authorized to be constructed substantially in accordance with the recommendation of the Chief of Engineers in House Document Numbered 304, Seventy-seventh Congress, first session, at an estimated cost of \$72,000.

#### WILLAMETTE RIVER BASIN

In addition to previous authorizations, there is hereby authorized to be appropriated the sum of \$11,000,000 for the prosecution of the comprehensive plan approved in the Act of June 28, 1938, for the Willamette River Basin in Oregon.

The project for improvement of the Pudding River in Oregon for flood control is hereby authorized to be constructed substantially in accordance with the recommendation of the Chief of Engineers in Senate Document Numbered 185, Seventy-sixth Congress, third session, at an estimated cost of \$62,000.

#### COLUMBIA RIVER BASIN

The project for local flood protection on the Touchet River at Dayton, Washington, is hereby authorized to be constructed substantially in accordance with the recommendation of the Chief of Engineers in House Document Numbered 662, Seventy-sixth Congress, third session, at an estimated cost of \$146,000.

The project for levees, channel enlargement, and channel rectification on Walla Walla River in the vicinity of Milton and Freewater, Oregon, is hereby authorized to be constructed substantially in accordance with the recommendation of the Chief of Engineers in House Document Numbered 719, Seventy-sixth Congress, third session, and the project for the protection of the city of Walla Walla, Washington, authorized by the Act approved June 28, 1938, is hereby modified in accordance with the recommendations of the Chief of Engineers, in House Document Numbered 719, Seventy-sixth Congress, third session, at an estimated cost of \$754,000.

The project for levees on the Cowlitz River, Washington, for local flood protection at Castle Rock, Washington, is hereby author-

ized to be constructed substantially in accordance with the recommendation of the Chief of Engineers in House Document Numbered 721, Seventy-sixth Congress, third session, at an estimated cost of \$31,000.

The project for local flood protection on Birch Creek in the vicinity of Pilot Rock, Oregon, is hereby authorized to be constructed substantially in accordance with the recommendation of the Chief of Engineers in Senate Document Numbered 89, Seventy-seventh Congress, first session, at an estimated cost of \$34,000.

Sec. 4. The Secretary of War is hereby authorized and directed to cause preliminary examinations and surveys for flood control, to be made under the direction of the Chief of Engineers, in drainage areas of the United States and its territorial possessions, which include the following-named localities, and the Secretary of Agriculture is authorized and directed to cause preliminary examinations and surveys for run-off and water-flow retardation and soil-erosion prevention on such drainage areas; the cost thereof to be paid from appropriations heretofore or hereafter made for such purposes: *Provided*, That after the regular or formal reports made on any examination, survey, project, or work under way or proposed are submitted to Congress, no supplemental or additional report or estimate shall be made unless authorized by law except that the Secretary of War may cause a review of any examination or survey to be made and a report thereon submitted to the Congress if such review is required by the national defense or by changed physical or economic conditions: *And provided further*, That the Government shall not be deemed to have entered upon any project for the improvement of any waterway or harbor mentioned in this Act until the project for the proposed work shall have been adopted by law:

Barren River, Kentucky and Tennessee, with special reference to a dam in the vicinity of a site known as Barren No. 2.

Byram River and tributaries, Connecticut.

Blind Brook and tributaries, New York.

Mamaroneck and Sheldrake Rivers and their tributaries, New York.

Bronx River and tributaries, New York.

Hutchinson River and tributaries, New York.

Saw Mill River and tributaries, New York.

Garden Creek, Mathews County, Virginia.

Indian River, Upper Saint Johns River and Marsh, and North Fork, Saint Lucie River, and their tributaries, the Kissimmee River and its tributaries, Florida.

Red River in the vicinity of Shreveport, Louisiana, with a view to determining the advisability of providing bank-protection works.

Polecat Creek, Creek County, Oklahoma.

Walnut Creek, Love and Carter Counties, Oklahoma.

Rio Grande and tributaries, New Mexico.

Mimbres River and tributaries, New Mexico.

Pearl River, Mississippi.

Lake Pontchartrain, Louisiana, from the Orleans-Jefferson Parish line westward and northward to the vicinity of Frenier.

Black River, Catahoula and Concordia Parishes, Louisiana.

Doggy and Clear Creeks, tributaries of the Arkansas River, Oklahoma.

Salt Creek of the Arkansas River and tributaries, Osage County, Oklahoma.

Red River of the North Drainage Basin, Minnesota, South Dakota, and North Dakota.

Inlets and outlets to Lake Hendricks, South Dakota and Minnesota.

North Fork and South Fork of the Shoshone River and their tributaries, Wyoming.

Emery River and tributaries, Tennessee.

Redstone and Dunlap Creeks and tributaries, Pennsylvania.

West Fork River and tributaries, West Virginia, with a view to determining the advisability of constructing a system of multiple-use reservoirs.

Milwaukee River and tributaries, Wisconsin.

Little Calumet River and tributaries, Indiana.

Little Black River and tributaries, Michigan.

Sturgeon and Otter Rivers, and their tributaries, Michigan.

Cuyahoga River and tributaries, Ohio.

Big Sur River and Carmel River, and their tributaries, Monterey County, California.

Laguna Canyon, California.

All streams in San Diego County, California, flowing into the Pacific Ocean.

All streams in San Diego and Imperial Counties, California, flowing into the Salton Sea.

Coyote River and tributaries, California.

San Francisquito Creek, San Mateo and Santa Clara Counties, California.

Alhambra Creek and tributaries, California.

Matadero Creek, Santa Clara County, California.

Novato Creek and its tributaries, Marin County, California.

Petaluma Creek and tributaries, Sonoma County, California.

Guadalupe River and tributaries, California.

Silvies River and tributaries, Oregon.

Columbia River and tributaries, Washington, from the downstream point of Vancouver Lake to upstream point of Bachelor Island.

Salmon Creek, in the vicinity of Juneau, Alaska.

Yaguez, Estero, Portuguese, Bucana, Lapa, Guamani, Chico, Maunabo, Quebrada Arena, and Susua Rivers, and tributaries, Puerto Rico.

Creque Gut and Fair Plain Gut and their tributaries, Island of Saint Croix, and of Turpentine Run, and Crown Mountain water courses and their tributaries, Island of Saint Thomas, Virgin Islands.

SEC. 5. That the Secretary of War is hereby authorized to allot, from any appropriations heretofore or hereafter made for flood control, not to exceed \$1,000,000 for any one fiscal year to be expended in rescue work or in the repair or maintenance of any flood-control work threatened or destroyed by flood.



SEC. 6. That the provisions of the following Acts of Congress relating to river and harbor improvements are hereby made applicable to works of flood control heretofore or hereafter authorized: August 8, 1917, section 9 (40 Stat. 267); July 18, 1918, sections 5 and 6 (40 Stat. 911); and August 30, 1935, section 7 (49 Stat. 1045).

SEC. 7. That 25 per centum of all moneys received and deposited in the Treasury of the United States during any fiscal year on account of the leasing of lands acquired by the United States for flood control purposes shall be paid, at the end of such year, by the Secretary of the Treasury to the State in which such property is situated, to be expended as the State legislature may prescribe for the benefit of the public schools and public roads of the county or counties in which such property is situated: *Provided*, That when such property is situated in more than one State or county the distributive share to each from the proceeds of such property shall be proportional to its area therein.

SEC. 8. Section 5 of the Act approved June 28, 1938 (52 Stat. 1215), is amended by striking out the words "in carrying out the purposes of this Act" and inserting in lieu thereof the words "in carrying out the purposes of the Act of June 22, 1936 (49 Stat. 1570), as amended and supplemented"; and by adding at the end of said section the following sentence: "The provisions of this section shall be applicable to any funds heretofore appropriated for the prosecution by the Secretary of Agriculture of works of improvement for measures of run-off and waterflow retardation and soil-erosion prevention upon watersheds."

SEC. 9. That Section 2 of the Flood Control Act of August 28, 1937, as amended is hereby further amended to read as follows:

"That the Secretary of War is hereby authorized to allot not to exceed \$500,000 from any appropriations heretofore or hereafter made for any one fiscal year for flood control, for removing accumulated snags and other debris and clearing and straightening channels in navigable streams and tributaries thereof, when in the opinion of the Chief of Engineers such work is advisable in the interest of flood control: *Provided*, That not more than \$25,000 shall be allotted for this purpose for any single tributary from the appropriations for any one fiscal year."

SEC. 10. That the sum of \$275,000,000 is hereby authorized to be appropriated for carrying out the improvements herein, the sum of \$10,000,000 additional is authorized to be appropriated and expended in equal amounts by the Departments of War and Agriculture for carrying out any examinations and surveys provided for in this Act and any other Acts of Congress, to be prosecuted by said departments. There is also hereby authorized to be appropriated for expenditure by the Department of Agriculture in carrying on works of improvement of the character specified in section 7 of the Flood Control Act of June 28, 1938, and which the Department is not otherwise authorized to undertake, such additional sums, not to exceed \$5,000,000, as may be necessary for that purpose. All appropriations necessary for operation and maintenance of flood-control works authorized by law to be operated and maintained by the United States are hereby authorized.

Approved, August 18, 1941.

LOS ANGELES AND SAN GABRIEL RIVERS AND THEIR  
TRIBUTARIES, AND BALLONA CREEK, CALIF.

---

LETTER

FROM

THE SECRETARY OF WAR

TRANSMITTING

A LETTER FROM THE CHIEF OF ENGINEERS, UNITED STATES ARMY, DATED APRIL 11, 1940, SUBMITTING A REPORT, TOGETHER WITH ACCOMPANYING PAPERS AND AN ILLUSTRATION, ON A PRELIMINARY EXAMINATION AND SURVEY OF LOS ANGELES AND SAN GABRIEL RIVERS AND THEIR TRIBUTARIES, AND BALLONA CREEK, CALIF., AUTHORIZED BY THE FLOOD CONTROL ACTS APPROVED JUNE 22, 1936, AND JUNE 28, 1938

---

JUNE 13, 1940.—Referred to the Committee on Flood Control and ordered to be printed, with an illustration

---

WAR DEPARTMENT,  
*Washington, June 11, 1940.*

THE SPEAKER OF THE HOUSE OF REPRESENTATIVES,

DEAR MR. SPEAKER: I am transmitting herewith a report dated April 11, 1940, from the Chief of Engineers, United States Army, on preliminary examination and survey of Los Angeles and San Gabriel Rivers and their tributaries, and Ballona Creek, Calif., authorized by the Flood Control Acts approved June 22, 1936, and June 28, 1938, together with accompanying papers and illustration.

Sincerely yours,

HARRY H. WOODRING,  
*Secretary of War.*

238719—40—1

2 LOS ANGELES AND SAN GABRIEL RIVERS AND BALLONA CREEK, CALIF.

WAR DEPARTMENT,  
OFFICE OF THE CHIEF OF ENGINEERS,  
*Washington, April 11, 1940.*

Subject: Los Angeles and San Gabriel Rivers and their tributaries,  
and Ballona Creek, Calif.

To: The Secretary of War.

1. I submit for transmission to Congress my report with accompanying papers and illustration on examinations of Los Angeles River and tributaries, Calif., and San Gabriel River and tributaries, Calif., authorized by the Flood Control Act approved June 22, 1936, and of Ballona Creek, Calif., made under the provisions of the Flood Control Act approved June 28, 1938, which authorized a preliminary examination and survey of streams in Los Angeles and Ventura Counties draining the Santa Monica Mountains, Calif., directly into the Pacific Ocean. Other reports under the latter authority are to be made.

2. The Los Angeles and San Gabriel Rivers and Ballona Creek drain an area of 1,717 square miles in southwestern California. The Los Angeles River is formed by the junction of Calabasas and Bell Creeks near the Los Angeles-Ventura County line, flows southeast 20 miles along the south side of the San Fernando Valley, then turns and flows south for 30 miles and discharges into the Pacific Ocean through a diversion channel in the city of Long Beach. It drains an area of 890 square miles including 137 square miles directly tributary to the Rio Hondo, a cross channel which carries part of the flow of the San Gabriel River to the Los Angeles River. The river traverses the agricultural and residential sections of the San Fernando Valley and the highly developed industrial sections of the city of Los Angeles. The San Gabriel River is formed by the junction of its East and West Forks in the San Gabriel Mountains. After leaving the mountains near the city of Azusa, the river divides into two branches, the branch to the west known as the Rio Hondo flowing southwest to its junction with the Los Angeles River, 12 miles from the ocean, and the branch to the east continuing south as the San Gabriel River to discharge into the Pacific Ocean 6 miles east of Los Angeles River. It drains an area of 698 square miles, exclusive of the area tributary to the Rio Hondo. Below Azusa to Whittier Narrows the river flows through a highly developed agricultural community. Below the Narrows it flows through a relatively well developed area suited to general agriculture except in the lower section which is mostly marsh and overflow land. Ballona Creek drains an area of 129 square miles adjoining the Los Angeles River basin on the west. The main stream is entirely within the coastal plain, but the numerous tributaries head in the mountains and foothills to the north. The upper portion of the Los Angeles and San Gabriel Basins lies within the Santa Susana and San Gabriel Mountains, and topography is rough and broken with the terrain cut by many steeply sloping canyons. Leaving the mountains, streams and washes flow through a foothill and valley area on fairly steep gradients until they enter the relatively flat coastal plain section. The three watersheds under consideration have an estimated population of 2,400,000, of which about 88 percent is urban, including 1,360,000, in the city of Los Angeles. Principal activities in the area are the production and

refining of petroleum, production of motion pictures, manufacturing, and agriculture.

3. Floods are comparatively frequent on the streams under consideration. The winter flood of 1861-62 appears to have been the greatest of historical record, but the magnitude of this or other floods except that of March 1938, is not known. Natural channels in the lower reaches are not stable and tend to change their courses. In 1815 the Los Angeles River changed its course from the general location of its present channel by turning west in the vicinity of what is now downtown Los Angeles, and flowing to the ocean by way of the present Ballona Creek. In 1825 the river returned to its original channel where it has remained except for numerous minor changes in alignment.

4. A total of about 325,000 acres is subject to overflow, 130,000 in the Los Angeles Basin, 140,000 in the San Gabriel Basin, 30,000 along the Rio Hondo, and 25,000 in the Ballona Creek Basin. Not all of this area would be inundated by any one flood, but due to the instability of natural channels and the relative freedom of flood flows to follow various courses over the debris cones and through the alluvial valleys the whole area is threatened. The present value of land and improvements of the entire overflow area is estimated at more than \$1,000,000,000, and the number of persons residing therein is approximately 800,000. In the upper Los Angeles Basin the overflow area consists mainly of citrus and olive groves and farm land, and contains many towns and improvements subject to flooding. Large areas in the cities of Burbank and Glendale are exposed to the flood menace and below in the flood plain of the Los Angeles River there are major industrial developments and a large part of the residential and business areas of Los Angeles. The overflow area south of Los Angeles includes the towns of Huntington Park, South Gate, Compton, and a portion of the city of Long Beach, as well as agricultural areas, oil fields, and refineries. The upper portion of the overflow area in the San Gabriel Basin consists principally of citrus groves, but contains no large communities. Below Whittier Narrows the flood plain contains small towns, truck farms, and oil fields, refineries, and tank farms. The towns of Bellflower, Artesia, Norwalk, and a portion of Long Beach are in this area. Along the Rio Hondo and its tributaries, sections of Pasadena, Sierra Madre, Arcadia, Monrovia, San Gabriel, Alhambra, and El Monte are subject to flood damage as well as extensive agricultural areas. Nearly all of the Ballona Creek overflow area is occupied by residential and industrial developments of Los Angeles, Beverly Hills, and Culver City. A small part of the southern portion of the area is in truck farms and contains a number of oil wells. Little information is available as to past flood damages except for the 1938 flood which caused damages estimated at over \$40,000,000. There was a large loss of life during this flood and during the 1934 flood.

5. Various local agencies have made extensive improvements in the area under consideration for the alleviation of the flood menace and for water conservation. The Los Angeles County Flood Control District, organized under authority of a State law enacted in 1915, developed comprehensive plans for control of floods in Los Angeles County and constructed extensive improvements, including 12 flood-control dams, 2 flood-control and debris storage basins, one diversion dam, a number of debris basins, many miles of channel improvements,

#### 4 LOS ANGELES AND SAN GABRIEL RIVERS AND BALLONA CREEK, CALIF.

and several areas as spreading grounds for water conservation. The Flood Control District maintains and operates all such works. The total expenditure from local funds for all work to December 1, 1939, was approximately \$57,800,000 for construction and \$11,000,000 for maintenance and operation, a total of \$68,800,000. The flood-control district contributed \$1,600,000 to the cost of diverting the lower Los Angeles River undertaken by the United States at a total cost of \$3,000,000 to eliminate silting of Los Angeles and Long Beach Harbors. Since 1935 numerous flood-control improvements have been constructed with Federal relief funds supplemented by contributions by local interests, the total expenditures being about \$21,000,000, of which \$5,000,000 were contributed. The existing project authorized by the 1936 Flood Control Act as amended by the act approved May 15, 1937, provides for the construction of reservoirs and principal flood channels in Los Angeles and San Gabriel Rivers and Ballona Creek, and tributaries thereof, at an estimated construction cost not to exceed \$70,000,000. Provisions of the 1938 Flood Control Act relieve local interests of the expense of lands, easements, and rights-of-way needed for the work, the cost of which is estimated at \$12,541,000. Federal expenditures under the existing project to January 1, 1940, have been \$37,540,000. The improvements that can be accomplished within the limits of expenditures authorized by the existing project consist of construction of the Hansen and Sepulveda flood-control basins and improvement of a part of the main channel and some tributary channels in the Los Angeles Basin, construction of the Santa Fe flood-control basin and improvement of short sections of channel in the San Gabriel Basin, and a small amount of channel work on Ballona Creek. Local interests state that numerous areas will be left unprotected from floods after completion of the works now authorized, and desire that a comprehensive plan for protection of the areas under consideration by construction of channel improvements, flood-control basins and debris basins be authorized.

6. The district engineer presents a general comprehensive plan for flood protection in the areas under consideration. The plan embodies the work provided for under the existing authorization and desirable extensions thereof. For the Los Angeles Basin the plan provides for the Sepulveda, Hansen, and Lopez flood-control basins, debris basins at the mouths of 17 tributary canyons, improvement of 49.07 miles of main channel and 53.42 miles of tributary channels and reconstruction of 109 bridges. For the San Gabriel Basin the plan provides for the Santa Fe and Whittier Narrows flood-control basins, debris basins at the mouths of 7 tributary canyons, improvement of 35.6 miles of main channel and 69.16 miles of tributary channels, and reconstruction of 142 bridges. For the Rio Hondo Basin the plan provides debris basins at mouths of 7 tributary canyons, improvement of 9.76 miles of main channel and 35.23 miles of tributary channels and reconstruction of 65 bridges. For Ballona Creek Basin the plan provides for debris basins at the mouths of two canyons, improvement of 2.39 miles of main channel and 23.67 miles of tributary channels and reconstruction of 12 bridges. Estimated costs of the general plan by basins follows:

|                          | Existing authorization | Proposed extensions | Total         |
|--------------------------|------------------------|---------------------|---------------|
| Los Angeles Basin.....   | \$67,283,000           | \$71,843,000        | \$139,126,000 |
| San Gabriel Basin.....   | 12,403,000             | 74,125,000          | 86,528,000    |
| Rio Hondo Basin.....     | 1,205,000              | 21,379,000          | 22,584,000    |
| Ballona Creek Basin..... | 1,950,000              | 18,276,000          | 20,226,000    |
| Total.....               | \$82,841,000           | \$185,623,000       | \$268,464,000 |

<sup>1</sup> Includes \$70,000,000 for construction and \$12,641,000 for lands and damages.

Annual charges for the general plan, including charges on works under the existing authorization are estimated at \$13,537,000. Benefits that would result from construction of the improvements proposed in the general plan, including benefits from works provided under the existing authorization are estimated to average \$20,666,000 annually. The district engineer finds the general plan as a whole and its individual elements all to be justified. He believes that in view of the local nature of the additional works proposed that local interests should participate in the expense of the additional improvements to the extent of providing all lands, easements, and rights-of-way, assuming the cost of all highway changes and bridges, holding the United States free from claims for damages except those resulting from faulty operation of the flood-control basins and, in the case of certain of the tributary channel improvements, to contribute 40 percent of the cost of construction. The district engineer recommends modification of the existing project for the Los Angeles and San Gabriel Rivers and Ballona Creek to provide for additional improvements in extension thereof at an estimated increase in first cost to the United States of \$131,000,000, with \$1,330,000 annually for maintenance and operation, subject to conditions of local cooperation. The division engineer concurs.

7. The Board of Engineers for Rivers and Harbors finds that the general plan proposed by the reporting officers provides a comprehensive outline of the works to be provided under the existing project and of the additional improvements required to afford protection to the areas for which protection now is found advisable. The Board has reviewed estimates of costs and benefits and finds that the estimates of direct flood damages that would be prevented under the plan have been carefully evaluated, and that they represent a fair determination of the direct benefits that would accrue to the project. It notes that these benefits represent nearly 90 percent of the annual charges for the comprehensive project. The Board, on the other hand, questions certain of the indirect and incidental benefits as estimated by the district engineer, and is of the opinion that only a nominal portion of these benefits would accrue to the project. The Board finds, however, that tangible benefits under the comprehensive plan are substantially equal to the annual charges and believes that when account is taken of indirect unevaluated benefits, including the continued economic welfare and development of the region, and of the serious hazard to life which now exists, the existing project works and proposed extensions thereof are well justified. The Board, while noting the large expenditures made by local interests on works useful to the general plan, believes that in view of the local character of the improvement local interests should be required to provide all lands, easements, and

rights-of-way needed for the proposed additional channel improvements, bear the expense of all highway and highway-bridge modifications in connection therewith, hold the United States free from claims for damages resulting from construction thereof and provide without cost police protection for all project works. Under these provisions the estimated costs of the proposed additional improvements would be \$163,500,000 to the United States and \$22,500,000 to local interests, a total of \$186,000,000. The Board believes that the proposed additional improvements are desirable and that they should be constructed in such a manner and sequence as to provide the maximum protection practicable throughout the construction period. It recommends that the plan substantially as outlined in the report of the district engineer be approved as the general comprehensive plan for flood control in Los Angeles and San Gabriel Rivers and Ballona Creek and tributaries thereof, subject to conditions of local cooperation, and that the work thereunder be prosecuted at such rates as may be determined by Congress.

8. After due consideration of these reports I concur in the views of the Board. Floods on Los Angeles and San Gabriel Rivers and Ballona Creek, and on tributaries thereof, inundate extensive areas of highly developed urban and agricultural property and cause large damages. There is also a serious hazard to human life. Extensive improvements for alleviation of flood conditions have been constructed by local interests and by the United States, and some additional work can be accomplished under the existing project. All of this work provides a very substantial degree of protection for certain areas, but there is urgent need that much additional work be undertaken. The general plan proposed by the district and division engineers provides a comprehensive outline of the works to be accomplished under the authorization for the existing project and of the additional improvements required to afford protection to the areas for which protection now is found advisable. The additional works proposed include: First, the construction of the Lopez and Whittier Narrows Flood Control Basins and of certain main stream channels, thereby completing the reservoirs and main channel system already initiated under the authorized project; and, second, improvement of numerous tributary channels and construction of debris basins at mouths of canyons. The work also includes extensive railroad, highway, and bridge changes. I concur with the Board that tangible benefits that would result from construction of the works under the general comprehensive plan are substantially equal to the annual charges and believe that when account is taken of indirect unevaluated benefits, including the continued economic welfare and development of the area, and of the serious hazard to life which now exists, the existing project works and proposed extensions thereof are justified. I also concur with the Board that in view of the essentially local character of the additional improvements now proposed, local interests should participate in the expense of the proposed additional channel improvement works to the extent of providing all lands, easements, and rights-of-way necessary for the construction of the channels, bearing the expense of all highway and bridge modifications needed in connection therewith, hold the United States free from claims for damages resulting from construction thereof, and that they should also be required to provide police protection for all completed flood-control works of the existing project or extensions.

thereof. I recommend that the plan, substantially as outlined in the report of the district engineer, be approved as the general comprehensive plan for flood control in Los Angeles and San Gabriel Rivers and Ballona Creek and tributaries thereof, subject to the conditions with respect to the proposed channel improvement works in extension of the existing project, that responsible local interests give assurances satisfactory to the Secretary of War that they will provide without cost to the United States all lands, easements, and rights-of-way necessary for the construction of said channels, bear the expense of all highway and highway bridge modifications needed in connection therewith, hold and save the United States free from claims for damages resulting from the construction thereof, and provide without cost to the United States police protection for all flood-control works of the existing project and extensions thereof; and that the work thereunder be prosecuted at such rates as may be determined by Congress.

J. L. SCHLEY,  
Major General, Chief of Engineers.

REPORT OF THE BOARD OF ENGINEERS FOR RIVERS AND  
HARBORS

[Second endorsement]

THE BOARD OF ENGINEERS FOR RIVERS AND HARBORS,  
Washington, D. C., March 26, 1940.

TO THE CHIEF OF ENGINEERS, UNITED STATES ARMY.

1. The Board considers that the general plan proposed by the district and division engineer for flood protection in the Los Angeles, San Gabriel, and Ballona Creek Basins provides a comprehensive outline of the works to be provided under the authorization for the existing project and of the additional improvements required to afford protection to the areas for which protection now is found advisable. The additional work proposed includes: First, the construction of the Lopez and Whittier Narrows flood-control basins and of certain main stream channels, thereby completing the reservoir and main channel system already initiated under the authorized project, and second, improvement of numerous tributary channels and construction of debris basins at mouths of canyons. The work also includes extensive railroad, highway, and bridge changes.

2. The Board has examined the plans for the additional work now proposed and has reviewed estimates of costs and benefits. It finds that the estimates of direct flood damages that would be prevented by the works proposed under the general comprehensive plan have been carefully evaluated, and believes that they represent a fair determination of the direct benefits that would accrue to the project. These benefits, estimated to average about \$11,700,000 annually, represent nearly 90 percent of the annual charges for the comprehensive project. The Board, on the other hand, questions certain of the indirect and incidental benefits as estimated by the district engineer and is of the opinion that only a nominal portion of these benefits would accrue to the project. The Board finds, however, that tangible benefits that would result from construction of the works under the general comprehensive plan are substantially equal to the



annual charges, and believes that when account is taken of indirect unevaluated benefits, including the continued economic welfare and further development of the area and of the serious hazard to life which now exists, the existing project works and proposed extensions thereof are justified.

3. The Board, while noting the large expenditures already made by local interests on works useful to the general plan, believes that in view of the essentially local character of the improvements, local interests should participate in the expense of the proposed additional channel improvement works to the extent of providing all lands, easements, and rights-of-way necessary for the construction of the channels, bearing the expense of all highway and highway bridge modifications needed in connection therewith, and holding the United States free from claims for damages resulting from construction thereof. Under these provisions the estimated costs of the proposed additional improvements would be \$163,500,000 to the United States and \$22,500,000 to local interests, a total of \$186,000,000. Local interests also should be required to provide, without cost to the United States, police protection for all completed flood-control works of the existing project and extensions thereof.

4. The Board believes that the additional improvements proposed by the district engineer are desirable and that they should be constructed in such a manner and sequence as to provide the maximum protection practicable throughout the construction period. The Board recommends that the plan, substantially as outlined in the report of the district engineer, be approved as the general comprehensive plan for flood control in Los Angeles and San Gabriel Rivers and Ballona Creek and tributaries thereof, subject to the conditions with respect to the proposed channel improvement works in extension of the existing project, that responsible local interests give assurances satisfactory to the Secretary of War that they will provide without cost to the United States all lands, easements, and rights-of-way necessary for the construction of said channels, bear the expense of all highway and highway-bridge modifications needed in connection therewith, hold and save the United States free from claims for damages resulting from the construction thereof, and provide without cost to the United States police protection for all flood-control works of the existing project and extensions thereof; and that the work thereunder be prosecuted at such rates as may be determined by Congress.

For the Board:

THOMAS M. ROBINS,  
*Brigadier General, Corps of Engineers,*  
*Senior Member.*

## SURVEY OF LOS ANGELES AND SAN GABRIEL RIVERS AND THEIR TRIBUTARIES, AND BALLONA CREEK, CALIF.

### SYLLABUS

The district engineer finds that an extension of the existing project for the control of destructive floods on the Los Angeles and San Gabriel Rivers and Ballona Creek, Calif., is necessary to attain full and satisfactory functioning of the existing project and that such extension is economically justified since the estimated benefits are more than one and one-half times the estimated costs. He sets forth

the items of the existing project that can be completed under existing congressional authorization and proposes extensions thereof to complete a comprehensive or general plan for control of floods in these basins.

The district engineer estimates:

The total cost of the extension of the existing project at \$186,000,000, of which the costs to local interests would be \$55,000,000.

The annual cost of operation and maintenance of the existing project and the extension thereof at \$1,330,000.

The district engineer recommends:

The adoption by the United States of a general plan for flood control, subject to the conditions that local interests--

Provide police protection for all completed flood-control works of the extension of the project and the existing project.

Hold and save the United States free from all claims for damages due to the construction and operation of the extension of the project, except damage claims caused by faulty manual operation of flood-control basins.

Provide, without cost of the United States, all lands, easements, and rights-of-way necessary for the construction of the extension of the project and assume the cost of the relocation of highways and highway bridges required in the extension of the project.

Contribute in advance, and as directed by the Chief of Engineers, United States Army, 40 percent of the construction cost of certain specified items of the general plan.

That the United States pay all other costs and perform all other work-entailed in connection with the construction, maintenance, and operation of the existing project and extension thereof.

That all items in the extension of the existing project be executed in accordance with plans to be approved by the Chief of Engineers, United States Army, and in the order directed by him.

That the United States operate and maintain all flood-control works of the existing project and extension thereof under the direction of the Secretary of War and supervision of the Chief of Engineers.

That those items, upon which local contributions of 40 percent of construction costs are required, be constructed only if and when local contributions are made.

That Federal funds be made available in allotments of not less than \$20,000,000 per annum.

WAR DEPARTMENT,  
UNITED STATES ENGINEER OFFICE,  
*Los Angeles, Calif., February 5, 1940.*

Subject: Survey report, flood control, Los Angeles and San Gabriel Rivers and their tributaries, and Ballona Creek, Calif.

To: The Chief of Engineers, United States Army [through the Division Engineer, South Pacific Division].

AUTHORITY

1. This report is submitted in compliance with an item in section 6 of the Flood Control Act approved June 22, 1936, H. R. 8455, which provides for a preliminary examination and survey for flood control of Los Angeles River and tributaries, Calif., and San Gabriel River and tributaries, Calif.

2. A report on preliminary examination, dated April 23, 1938, was submitted in accordance with the above act and in accordance with an act approved March 6, 1936, H. R. 7147, which latter act provides for a preliminary examination of the Los Angeles and San Gabriel Rivers and their tributaries. The report was reviewed by the Board of Engineers for Rivers and Harbors, and pursuant to the recommendation of the Board to the Chief of Engineers a survey was authorized on September 30, 1938. A survey report was submitted to the Chief of Engineers under date of March 15, 1939, in compliance with the foregoing acts, which report was returned by the Chief of Engi-

neers for revision upon recommendation of the Board of Engineers for Rivers and Harbors.

3. Ballona Creek Basin is considered in this report for the following reasons. Section 5 of the act of June 22, 1936, authorized the construction of reservoirs and principal flood channels on the Los Angeles and San Gabriel Rivers, Calif. This act was amended by an act approved May 15, 1937, S. 1571, which changed the project title to read, "Los Angeles County Drainage Area, Calif.," and changed the text to read, "Construction of reservoirs and principal flood channels in Los Angeles and San Gabriel Rivers and Ballona Creek and tributaries thereof." In view of the inclusion of Ballona Creek in the existing project and since the Flood Control Act of June 28, 1938, authorized report thereon under title "Streams in Los Angeles and Ventura Counties draining the Santa Monica Mountains, Calif., directly into the Pacific Ocean," it is considered more appropriate to include that basin in this survey report. This procedure avoids inclusion of an item of the existing project in a preliminary examination report and preserves the geographical grouping of the existing project streams herein discussed.

#### PRIOR REPORTS

4. A preliminary examination and survey of Los Angeles and Long Beach Harbors, Calif., and their tributary waters, with a view to the protection of the harbors from silt deposits, called for by the River and Harbor Act of July 25, 1912, was made and published in House Document 462, Sixty-fourth Congress, first session. A further report on this subject, "Reconsideration and Modification of Preliminary Examination and Survey of Los Angeles and Long Beach Harbors, Calif.," authorized by the River and Harbor Act of July 17, 1916, was made and published in House Document 9, Sixty-fourth Congress, second session. The Los Angeles and San Gabriel Rivers and the Rio Hondo were considered in both reports. Based on these reports a project was adopted for the diversion of the Los Angeles River outside of and to the east of Los Angeles and Long Beach Harbors and completed in 1923.

5. A flood-control report dated May 22, 1935, upon an application made under the provisions of the Federal Emergency Relief Appropriation Act of 1935 by the Los Angeles County Flood Control District, was submitted by the district engineer. This report was the basis for the adoption of 14 flood-control projects for unemployment relief.

6. Numerous investigations and surveys of the area for flood control, water supply, and other purposes have been made by the Los Angeles County Flood Control District, by local agencies, and by interested persons. A list of these reports, including a brief description of their contents is presented in enclosure 3.<sup>1</sup>

#### DESCRIPTION

7. *Location.*—The drainage basins of the Los Angeles and San Gabriel Rivers and Ballona Creek are in southwestern California, principally within Los Angeles County. Small portions extend into the adjacent counties of Ventura, San Bernardino, and Orange. The drainage area, 1,717 square miles, extends southerly from the Santa

<sup>1</sup> Not printed.

Susana and San Gabriel Mountains, Sierra Madre Range, to the Pacific Ocean. The eastern boundary lies in the Puente Hills and the western boundary in the Santa Monica Mountains and Simi Hills.

8. *Climate*.—The climate is subtropical and semiarid. Normal annual maximum, minimum, and average temperatures from the 61-year record of the Los Angeles office of the United States Weather Bureau are 73°, 53°, and 63°, respectively. The average annual precipitation varies from about 10 inches near the coast to about 40 inches near the crest of the mountains. Approximately 80 percent of the annual precipitation falls during the 4-month period from December to March. On an average there are only 38 days a year during which precipitation occurs in a measurable amount. Mean relative humidity at Los Angeles averages 77 percent at 5 a. m. and 61 percent at 5 p. m. The maximum wind movement recorded by the United States Weather Bureau is 38 miles per hour and the average is 6.1 miles per hour.

9. *Topography*.—The upper portion of the area, lying within the Santa Susana and San Gabriel Mountains, is rough and broken, with the terrain cut by many steeply sloping canyons. Between the base of the major mountain range and the northern edge of the coastal plain there are two distinct foothill ranges which traverse the western part of the area in a general east and west direction, roughly paralleling the Sierra Madres. The most northerly of these is made up of the Verdugo Mountains and the San Rafael Hills; the other consists of the Hollywood spur of the Santa Monica Mountains extending into the area from the west. In the eastern part of the area there are two similar ranges, the San Jose Hills and an extension of the Puente Hills. Between the northern edge of the coastal plain and the Pacific Ocean there are several smaller hills, among which are the Baldwin and Dominguez Hills and the Palos Verdes (San Pedro) Hills. Of these, the latter are the most important as they have influenced the shore line along the southern boundary of the area.

10. The major topographic divisions may be classified as follows:

*Major topographic divisions, drainage basins of the Los Angeles and San Gabriel Rivers and Ballona Creek*

| County              | Mountain area  | Foothill and valley area | Coastal plain area | Total          |
|---------------------|----------------|--------------------------|--------------------|----------------|
|                     | (Square miles) | (Square miles)           | (Square miles)     | (Square miles) |
| Los Angeles.....    | 705            | 447                      | 416                | 1,568          |
| Orange.....         | 0              | 42                       | 84                 | 126            |
| Ventura.....        | 11             | 0                        | 0                  | 11             |
| San Bernardino..... | 12             | 0                        | 0                  | 12             |
| Total.....          | 728            | 489                      | 500                | 1,717          |

11. Elevations of the drainage areas range from sea level to 10,080 feet at the summit of Mount San Antonio in the northeast. The mountains in the northern limits of the area decrease in elevation to approximately 3,000 feet in the northwest, the general altitude varying between 5,000 and 7,000 feet. The slopes of the mountains from base to summit average about 1,000 feet per mile, and the stream channels consequently are steep, with gradients varying from 8 to 40 percent.

## 12 LOS ANGELES AND SAN GABRIEL RIVERS AND BALLONA CREEK, CALIF.

Through the valley areas the land slopes are high, averaging approximately 50 feet per mile. The stream channels and washes have about the same gradients. The coastal plain area is relatively flat, having an average gradient of about 0.2 percent.

12. *Geology and soils.*—Before the Tertiary period the whole region passed through a long process of peneplanation until it became an area of low relief. During the Tertiary period the area was covered to a great depth by marine deposits. The two youngest of the series of marine deposits, the Puente and Fernando formations, are placed in the Miocene and Pliocene periods respectively. During and after deposition of the Puente formations there were earth movements of great magnitude, and the most severe folding of the Puente Hills occurred toward the end of the Pliocene period. However, the main orogenic movement occurred later when the tilted block of the San Gabriel Mountains was thrown up along the San Gabriel Fault; the Puente and Fernando formations were moderately folded by a major uplift along the Whittier Fault, the granitic mass of the Verdugo Mountains being thrown up to the west and the San Jose Hills to the east.

13. The mountain slopes and canyons are composed principally of disintegrated igneous rock which is readily erodible where it is not protected by forest covering. The thin soils of these areas and the lack of rainfall during the greater portion of the year limit vegetation to a sparse growth consisting principally of live oak and chaparral. During the dry months these growths, averaging 4 to 10 feet in height, become subject to fires. After a fire the soil is exposed to erosion, and from 3 to 5 years is required for a regrowth of the brush cover.

14. The valley areas are pervious alluvial deposits of silt, sand, and gravel of great depth, underlain and surrounded by relatively impervious rock, principally crystalline, metamorphic, and igneous. The coastal plain is similar in composition to the valleys, but the deposits are less coarse and are interspersed with fine sand and clay. The soils of the valley and coastal plain areas consist mainly of sandy and clay loams which are usually very fertile. Natural growths are prairie grass, sagebrush, chaparral, oaks, and, along the watercourses, willow trees. Walnuts, citrus fruits, and a wide variety of general farm crops are cultivated in the irrigated areas, and forage crops susceptible to dry farming are grown where water for irrigation is lacking.

15. *Population.*—The present population of the drainage areas of the Los Angeles and San Gabriel Rivers and Ballona Creek is estimated at 2,400,000, of which about 88 percent is urban and 12 percent rural. Because of the rapid influx of people to southern California since the last general census in 1930, estimates of the present population are considered roughly approximate. There are 44 incorporated cities within the area, with a combined population in 1930 of 1,925,775. The largest is the city of Los Angeles (population, 1,360,000—1939 estimate, Los Angeles chamber of commerce) which has the greatest area of any city in the United States.

16. The general distribution of population is shown on page 2<sup>1</sup> of enclosure 1. The growth of population in Los Angeles County during the period 1880 to 1938 is indicated by the following tabulation taken from the United States Census, with the exception of 1938, which is an estimate of the Los Angeles Chamber of Commerce.

<sup>1</sup> Not printed.

*Population of Los Angeles County*

| Year:     | Population | Year:     | Population  |
|-----------|------------|-----------|-------------|
| 1880..... | 33, 381    | 1920..... | 936, 455    |
| 1890..... | 101, 454   | 1930..... | 2, 208, 492 |
| 1900..... | 170, 298   | 1938..... | 2, 450, 000 |
| 1910..... | 504, 131   |           |             |

17. *Production activities.*—Natural resources consist principally of petroleum, natural gas, and highly productive agricultural land. Of secondary importance are stone, clays, and mineral waters. The mild climate attracts a large number of tourists whose trade is an important source of income.

18. The major productive activities in the area are petroleum production and refining, motion-picture production, airplane production, automobile assembling, miscellaneous manufacturing, and agriculture. The gross return from industrial activity amounted to more than \$1,350,000,000 in 1937, and from agricultural production more than \$76,000,000 in 1938. Bank debits in the city of Los Angeles were over \$9,787,000,000 in 1938, a weekly average of about \$188,200,000. The gross assessed valuation for Los Angeles County in 1938 was \$3,024,239,435, which represents a true value of about \$5,600,000,000. Statistical details for Los Angeles County are given in enclosure 2.<sup>1</sup>

19. *Lines of communication.*—Transcontinental rail facilities are provided by three major lines: The Atchison, Topeka, and Santa Fe Railway, the Southern Pacific Co., and the Union Pacific Railroad. Two electric railways and various bus lines furnish local service. An extensive system of National and State highways and a well-improved secondary-road system permit easy access to all parts of the area. Transcontinental and local truck and bus lines furnish important additions to the transportation facilities.

20. Four major airports and numerous smaller ones provide landing fields for a growing number of private and commercial aircraft. Four transcontinental and two west coast air lines operate from Los Angeles under about 30 daily schedules. Principal highways, railroad lines, and airports are shown on page 3<sup>1</sup> of enclosure 1.

21. The combined harbor of Los Angeles and Long Beach is noted as one of the largest artificial ports in the world. Adequate terminal and transfer facilities are provided for foreign and domestic commerce. For the fiscal year July 1, 1937, to June 30, 1938, the commerce passing through the port amounted to 22,661,126 tons valued at \$1,040,855,422.

22. *Streams—general.*—Four major streams and numerous tributaries drain the area. The major streams are the Los Angeles and San Gabriel Rivers, their interconnecting stream the Rio Hondo, and Ballona Creek. The first two have their sources in the high mountains forming the northern boundary of the area; the last two are confined to the foothills and coastal plain. During major storms, large areas in each stream basin, shown on page 2<sup>1</sup> of enclosure 1, are subject to damage from floods.

23. *Los Angeles River.*—The Los Angeles River is formed by the confluence of Calabasas Creek and Bell Creek, which have their sources in the Simi Hills and the Santa Monica Mountains near the

<sup>1</sup> Not printed.

Los Angeles-Ventura County line. The main stream flows southeasterly for about 20 miles along the south side of the San Fernando Valley and thence through the narrows between the Santa Monica Mountains and the San Rafael Hills where it turns south and flows about 30 miles, entering the Pacific Ocean through a diversion channel in the city of Long Beach immediately east of the breakwater of Los Angeles and Long Beach Harbors. The river channel traverses the agricultural and residential sections of San Fernando Valley and the highly developed industrial districts of the city of Los Angeles.

24. The main channel of the Los Angeles River is approximately 50 miles long, and its tributaries have an aggregate length of about 225 miles. The principal tributaries in downstream order are Bell Creek, Calabasas Creek, Brown's Canyon Creek, Aliso Creek, Caballero Creek, Bull Creek, Encino Creek, Pacoima Wash, Tujunga Wash, Studio City Wash, Burbank Wash (west), Burbank Wash (east), Verdugo Wash, Sycamore Wash, Arroyo Seco, Rio Hondo, Compton Creek, and Laguna Dominguez, formerly Nigger Slough. This last name was changed by the Board of Supervisors of Los Angeles County. Since completion of the Los Angeles River diversion channel, Laguna Dominguez has emptied into Los Angeles Harbor.

25. The drainage area of the Los Angeles River excluding the Rio Hondo is 753 square miles, or approximately 44 percent of the area considered in this report. The topographic divisions are as follows:

*Major topographic divisions of the Los Angeles River Basin*

| Topographic division—         | Square<br>miles in<br>Los Angeles<br>County |
|-------------------------------|---------------------------------------------|
| Mountain area.....            | 1 283                                       |
| Foothill and valley area..... | 285                                         |
| Coastal plain area.....       | 1 185                                       |
| Total.....                    | 753                                         |

<sup>1</sup> Includes 11 square miles in Ventura County.

<sup>2</sup> Includes Laguna Dominguez, 72 square miles, now excluded by levee of Los Angeles River diversion channel which is located to the east.

26. *San Gabriel River.*—The San Gabriel River is formed by the confluence of its East and West Forks in the San Gabriel Mountains in the northeastern part of the drainage area. The source of the East Fork is at elevation about 10,000 feet and that of the West Fork about 7,000 feet. At the base of the mountains near the city of Azusa the main stream has an elevation of 1,000 feet above sea level. After leaving the mountains the river flows over its alluvial cone in a poorly defined channel. About 3 miles below Azusa the deposit of sand, gravel, and boulders has divided the channel into two branches. The branch to the west is known as the Rio Hondo, tributary to the Los Angeles River. The branch to the east continues as the San Gabriel River in a southerly direction through Whittier Narrows, emptying into the Pacific Ocean through the present outlet channel of Alamitos Bay about 6 miles east of the mouth of the Los Angeles River. Above Whittier Narrows the main stream flows through a highly developed agricultural community. Below the narrows the area is relatively well developed and suited to general agriculture, except for the lower 5 to 8 miles which is mostly marsh and overflow land.

27. The length of the San Gabriel River is approximately 58 miles, including its headwater tributary, East Fork. The principal tributaries, in downstream order, are West Fork, East Fork, Roberts Canyon, Fish Canyon, Walnut Creek, San Jose Creek, Sycamore Canyon, and Coyote Creek.

28. The drainage area of San Gabriel River is 698 square miles, or about 41 percent of the area considered in this report. The topographic divisions are as follows:

*Major topographic divisions of the San Gabriel River Basin*

| Topographic division          | Square miles in Los Angeles County | Square miles in Orange County | Total square miles |
|-------------------------------|------------------------------------|-------------------------------|--------------------|
| Mountain area.....            | 1 270                              |                               | 270                |
| Foothill and valley area..... | 206                                | 42                            | 248                |
| Coastal plain area.....       | 90                                 | 84                            | 180                |
| Total.....                    | 572                                | 126                           | 698                |

<sup>1</sup> Includes 12 square miles in San Bernardino County.

29. *Rio Hondo*.—The Rio Hondo, although a tributary of the Los Angeles River, connects with the San Gabriel River. It receives most of its flow from the latter, but also drains the adjacent area to the north and northwest of its own channel and in time of flood may carry more water than the San Gabriel River.

30. Branching from the San Gabriel River about 3 miles below the canyon mouth, the Rio Hondo flows in a southerly direction for 8 miles, passing through Whittier Narrows about 1 mile west of the present San Gabriel River channel, and thence southwesterly for a distance of 12 miles where it joins the Los Angeles River at a point 12 miles from the ocean. The course of the stream is through areas the development of which is similar to that along the San Gabriel River.

31. The length of the Rio Hondo is approximately 20 miles, and the aggregate length of its tributaries about 60 miles. The principal tributaries in downstream order are Bradbury Canyon wash, Spinks Canyon wash, Sawpit wash, Santa Anita wash, Arcadia wash, Eaton wash, Rubio wash, and Alhambra wash.

32. The normal drainage area of the Rio Hondo is 137 square miles, or about 8 percent of the area considered in this report. The topographic divisions are as follows:

*Major topographic divisions of the Rio Hondo Basin*

| Topographic division:         | Square miles in Los Angeles County |
|-------------------------------|------------------------------------|
| Mountain area.....            | 37                                 |
| Foothill and valley area..... | 94                                 |
| Coastal plain area.....       | 6                                  |
| Total.....                    | 137                                |

33. *Ballona Creek*.—Ballona Creek and its tributaries drain the area on the western edge of the Los Angeles River Basin between the Santa Monica Mountains and the Pacific Ocean. The main stream is entirely within the coastal plain, but the numerous tributaries con-



centrate the run-off from the mountains and foothills to the north. Most of the drainage basin is highly developed urban and suburban area.

34. The length of the main channel of Ballona Creek is approximately 9 miles. Storm drains constructed in this area have replaced and modified to a considerable extent the natural drainage channels of the tributaries. The major improved channels that discharge into Ballona Creek, in downstream order, are Arroyo de los Jardines, La Cienega storm drain, Jefferson and Adams storm drain, Slauson storm drain, Benedict Canyon storm drain, Sawtelle-Westwood storm drain (from Sepulveda Canyon), and Centinela Creek.

35. The total drainage area of Ballona Creek is 129 square miles, or about 7 percent of the area under consideration. The topographic divisions are as follows:

| Topographic division:         | Square miles in<br>Los Angeles County |
|-------------------------------|---------------------------------------|
| Mountain area.....            | 30                                    |
| Foothill and valley area..... | 13                                    |
| Coastal plain area.....       | 86                                    |
| Total.....                    | 129                                   |

36. *Bridges.*—In common with all highly developed districts, the stream channels are spanned by many railroad and highway bridges and utility crossings. Prior to the flood of March 1938, the 4 major stream channels were crossed by 152 bridges, 81 of which were on the Los Angeles River, 33 on the San Gabriel River, 19 on the Rio Hondo, and 19 on Ballona Creek. The map on page 4<sup>1</sup> of enclosure 1 shows the location of these bridges and indicates their condition after the flood. Damage to bridges by the flood was extensive, amounting to complete demolition in a number of cases.

37. Throughout the area there is a total of about 900 bridges and culverts, including those mentioned above. A complete list of bridges is given in enclosure 4.<sup>1</sup> About half of the bridges are involved in proposed flood-control improvements and are discussed further in enclosures 7<sup>1</sup> and 8.<sup>1</sup>

#### EXISTING PROJECT

38. The Flood Control Act approved June 22, 1936 (H. R. 8455), amended by the act approved May 15, 1937 (S. 1571), authorized:

Construction of reservoirs and principal flood channels "in Los Angeles and San Gabriel Rivers and Ballona Creek and tributaries thereof," in accordance with plans to be approved by the Chief of Engineers on recommendation of the Board of Engineers for Rivers and Harbors at an estimated construction cost not to exceed \$70,000,000; estimated cost of lands and damages, \$5,000,000.

The act of June 22, 1936, provides:

SEC. 3. That hereafter no money appropriated under authority of this Act shall be expended on the construction of any project until States, political subdivisions thereof, or other responsible local agencies have given assurances satisfactory to the Secretary of War that they will (a) provide without cost to the United States all lands, easements, and rights-of-way necessary for the construction of the project, except as otherwise provided herein; (b) hold and save the United States free from damages due to the construction works; (c) maintain and operate all the works after completion in accordance with regulations prescribed by the Secretary of War: *Provided*, That the construction of any dam authorized herein may be

<sup>1</sup> Not printed.

undertaken without delay when the dam site has been acquired and the assurances prescribed herein have been furnished, without awaiting the acquisition of the easements and rights-of-way required for the reservoir area: *And provided further*, That whenever expenditures for lands, easements, and rights-of-way by States, political subdivisions thereof, or responsible local agencies for any individual project or useful part thereof shall have exceeded the present estimated construction cost therefor, the local agency concerned may be reimbursed one-half of its excess expenditures over said estimated construction cost: *And provided further*, That when benefits of any project or useful part thereof accrue to lands and property outside of the State in which said project or part thereof is located, the Secretary of War with the consent of the State wherein the same are located may acquire the necessary lands, easements, and rights-of-way for said project or part thereof after he has received from the States, political subdivisions thereof, or responsible local agencies benefited the present estimated cost of said lands, easements, and rights-of-way, less one-half the amount by which the estimated cost of these lands, easements, and rights-of-way exceeds the estimated construction cost corresponding thereto: *And provided further*, That the Secretary of War shall determine the proportion of the present estimated cost of said lands, easements, and rights-of-way that each State, political subdivision thereof, or responsible local agency should contribute in consideration for the benefits to be received by such agencies: *And provided further*, That whenever not less than 75 per centum of the benefits as estimated by the Secretary of War of any project or useful part thereof accrue to lands and property outside of the State in which said project or part thereof is located, provision (c) of this section shall not apply thereto; nothing herein shall impair or abridge the powers now existing in the Department of War with respect to navigable streams: *And provided further*, That nothing herein shall be construed to interfere with the completion of any reservoir or flood control work authorized by the Congress and now under way.

The act of June 22, 1936, was amended by section 2 of the act approved June 28, 1938, reading as follows:

SEC. 2. That section 3 of the Act of June 22, 1936 (Public Numbered 738, Seventy-fourth Congress), as heretofore amended and as herein further modified, shall apply to all flood-control projects, except as otherwise specifically provided by law.

That in case of any dam and reservoir project, or channel improvement or channel rectification project for flood control, herein authorized or heretofore authorized by the Act of June 22, 1936 (Public Numbered 738, Seventy-fourth Congress), as amended, and by the Act of May 15, 1928 (Public Numbered 391, Seventieth Congress), as amended by the Act of June 15, 1936 (Public Numbered 678, Seventy-fourth Congress), as amended, title to all lands, easements, and rights-of-way for such project shall be acquired by the United States or by States, political subdivisions thereof or other responsible local agencies and conveyed to the United States, and provisions (a), (b), and (c) of section 3 of said Act of June 22, 1936, shall not apply thereto. Notwithstanding any restrictions, limitations, or requirement of prior consent provided by any other Act, the Secretary of War is hereby authorized and directed to acquire in the name of the United States title to all lands, easements, and rights-of-way necessary for any dam and reservoir project or channel improvement or channel rectification project for flood control, with funds heretofore or hereafter appropriated or made available for such projects, and States, political subdivisions thereof, or other responsible local agencies, shall be granted and reimbursed, from such funds, sums equivalent to actual expenditures deemed reasonable by the Secretary of War and the Chief of Engineers and made by them in acquiring lands, easements, and rights-of-way for any dam and reservoir project, or any channel improvement or channel rectification project for flood control heretofore or herein authorized: *Provided*, That no reimbursement shall be made for any indirect or speculative damages: *Provided further*, That lands, easements and rights-of-way shall include lands on which dams, reservoirs, channel improvements, and channel rectifications are located; lands or flowage rights in reservoirs and highway, railway, and utility relocation.

The above acts form the basis of the existing Federal flood control project, which will be referred to in this report as the existing project. Portions of the existing project have been completed, some parts are now in various stages of construction, and work on other units has

18 LOS ANGELES AND SAN GABRIEL RIVERS AND BALLONA CREEK, CALIF.

not yet been started. The project has now progressed to the state that the following estimate of the items that will be completed under existing authorization may be considered fairly accurate:

*Existing project Los Angeles and San Gabriel Rivers and their tributaries and Ballona Creek, Calif., estimated costs*

| Project Item                                                                      | Construction<br>1 | Public utilities<br>2 | Bridges<br>3 | Lands and rights-of-way<br>4 | Project sub-totals<br>5 | Basin totals<br>6 | Percent complete Jan. 1, 1940 |
|-----------------------------------------------------------------------------------|-------------------|-----------------------|--------------|------------------------------|-------------------------|-------------------|-------------------------------|
| <b>LOS ANGELES RIVER BASIN</b>                                                    |                   |                       |              |                              |                         |                   |                               |
| Hansen Flood Control Basin.....                                                   | \$8,500,000       | \$480,000             | -----        | \$1,400,000                  | \$10,380,000            | -----             | 82                            |
| Sepulveda Flood Control Basin.....                                                | 4,000,000         | 364,000               | -----        | 2,457,000                    | 6,821,000               | -----             | 0                             |
| Los Angeles River Channel—Niagara St. to Stewart and Gray Road.....               | 41,355,612        | 1,199,334             | \$1,783,855  | 725,706                      | 45,067,607              | -----             | 54                            |
| Long Beach Blvd.....                                                              | 34,244            | -----                 | -----        | -----                        | 34,244                  | -----             | 100                           |
| Haines Canyon.....                                                                | 520,423           | 3,110                 | -----        | 103,233                      | 626,766                 | -----             | 100                           |
| Sycamore Canyon.....                                                              | 23,540            | -----                 | -----        | 4,439                        | 27,985                  | -----             | 100                           |
| Verdugo Wash.....                                                                 | 588,519           | 21,989                | 260,367      | 216,438                      | 1,087,313               | -----             | 100                           |
| Compton Creek.....                                                                | 1,892,640         | 30,408                | 678,509      | 239,096                      | 2,841,662               | -----             | 100                           |
| Surveys and Engineering.....                                                      | 396,206           | -----                 | -----        | -----                        | 396,206                 | -----             | -----                         |
| Totals, Los Angeles River Basin.....                                              | 57,311,199        | 2,098,841             | 2,725,731    | 5,146,902                    | 67,282,673              | 67,282,673        | -----                         |
| <b>SAN GABRIEL RIVER BASIN</b>                                                    |                   |                       |              |                              |                         |                   |                               |
| Santa Fe Flood Control Basin.....                                                 | 8,899,000         | 50,000                | -----        | 1,068,000                    | 10,017,000              | -----             | 0                             |
| San Gabriel River Channel—San Gabriel Canyon to Santa Fe Flood Control Basin..... | 1,720,000         | 12,000                | 204,000      | 150,000                      | 2,086,000               | -----             | 0                             |
| Totals, San Gabriel River Basin.....                                              | 10,619,000        | 62,000                | 204,000      | 1,218,000                    | 12,103,000              | 12,103,000        | -----                         |
| <b>RIO HONDO BASIN</b>                                                            |                   |                       |              |                              |                         |                   |                               |
| Alhambra Wash.....                                                                | 1,017,586         | 34,902                | 61,905       | 91,220                       | 1,205,613               | -----             | 100                           |
| Totals, Rio Hondo Basin.....                                                      | 1,017,586         | 34,902                | 61,905       | 91,220                       | 1,205,613               | 1,205,613         | -----                         |
| <b>BALLONA CREEK BASIN</b>                                                        |                   |                       |              |                              |                         |                   |                               |
| Ballona Creek Channel.....                                                        | 752,215           | 91,165                | 412,141      | 394,579                      | 1,650,100               | -----             | 100                           |
| Ballona Creek Jetties.....                                                        | 300,000           | -----                 | -----        | -----                        | 300,000                 | -----             | 60                            |
| Totals, Ballona Creek Basin.....                                                  | 1,052,215         | 91,165                | 412,141      | 394,579                      | 1,950,100               | 1,950,100         | -----                         |
| Totals, existing project.....                                                     | 70,000,000        | 2,286,908             | 3,403,777    | 6,850,701                    | -----                   | 82,541,386        | -----                         |

39. The total Federal cost of the existing project to January 1, 1940, was \$37,539,896, of which \$11,009,373 was from E. R. A. funds and \$26,530,523 was from regular funds. Local contributions reimbursable by the United States amounting to \$459,703 bring the Federal costs and audited obligations up to \$37,999,599. The \$12,385,959 remaining from fiscal year 1940 appropriations will be expended or obligated before the end of the fiscal year. The total estimated cost of the existing project, including the costs of rights-of-way, bridges, and public utilities, is \$82,540,000.

## EXISTING IMPROVEMENTS

40. *General.*—Various local agencies have made extensive improvements in the area for the alleviation of the flood menace and for water conservation. The accomplishments of these agencies and Federal participation in this work are discussed briefly in the following paragraphs.

41. *Los Angeles County Flood Control District.*—The Los Angeles County flood-control district was organized under authority of the Los Angeles County Flood Control Act, a State law enacted in 1915. The district defined by the above act includes the entire drainage area considered in this report except the small portions lying in Orange, San Bernardino, and Ventura Counties. The State act provides for the preparation of comprehensive plans for flood control and water conservation, for the construction of improvements for such purposes, and for cooperation with other agencies.

42. A comprehensive plan of development was prepared by the flood-control district, and until 1935 all major flood-control and water-conservation projects were constructed in accordance with the plan with the exception of the Los Angeles River diversion channel, which was constructed by the Federal Government in cooperation with the flood control district, at a cost of \$1,400,000 to the Federal Government and \$1,600,000 to the Flood Control District. This channel was constructed through the city of Long Beach in order to eliminate silting of the Los Angeles and Long Beach Harbors. Upon completion of the construction in 1923, the diversion channel was turned over to the flood-control district for maintenance. Since 1935 the construction of permanent improvements for flood control has been prosecuted largely by Federal agencies under Federal financing. However, the Los Angeles County Flood Control District, after the passage of the Flood Control Act of June 22, 1936, cooperated actively in its function of providing rights-of-way and assuming responsibility for damages and in maintaining those works which it had constructed. Even after the passage of the Flood Control Act of June 28, 1938, it continued to be of great assistance in securing rights-of-way. The flood-control district has been reimbursed under the provision of the act of June 28, 1938, to the amount of \$568,697.98 for expenditures made in connection with the existing project subsequent to the passage of the act of June 22, 1936. Further reimbursements, variously estimated from \$2,000,000 to \$3,000,000, may be made as funds therefor become available.

43. Improvements made solely by the flood-control district include 12 flood-control dams, two flood-control and debris storage basins, one diversion dam, many miles of channel improvements, debris basins, and the development of several areas as spreading grounds for water conservation. The flood-control district maintains and operates all such works. Pertinent data for the dams are given in exhibit 29 of enclosure 6,<sup>1</sup> and their locations are shown on page 1 of enclosure 1. The total expenditure from local funds for all work, including maintenance and operation, to December 1, 1939, was approximately \$68,800,000. Of the total local expenditure of \$68,800,000, the expenditure for maintenance and operation was about \$11,000,000, leaving a total capital investment of \$57,800,000. Some parts of the work constructed with this capital investment

<sup>1</sup> Not printed.

may be considered temporary channel improvement made for the immediate alleviation of the flood menace, with the expectation that permanent improvements would be constructed at a later date. The temporary channel work was chiefly 25 miles of pile and wire fence and 70 miles of pipe and wire fence. Data are not available for the exact cost of the temporary channel fencing, but an approximate estimate is \$2,400,000. Subtracting the approximate cost of the temporary work from the \$57,800,000 total capital investment leaves a balance of \$55,400,000, which may be considered to represent the capital investment in permanent work by the Los Angeles County Flood Control District. Although a small part of this investment might be credited to water conservation, by far the greater part represents flood control.

44. *Los Angeles County engineer's office.*—Prior to 1933 this agency spent about \$6,800,000 of local funds, almost all of which was spent between 1923 and 1932. From 1933 to 1935 about \$680,000 was spent, \$270,000 of which was from local funds and \$410,000 from the Reconstruction Finance Corporation, the Civil Works Administration and the State Emergency Relief Administration. The State was the major contributor. From October 1935 to January 1940 this agency has expended about \$900,000 sponsoring Work Projects Administration construction entailing an expenditure of \$10,400,000 of Federal funds. The county engineer's office is therefore accredited with an expenditure of \$7,970,000 of local money and \$10,810,000 from other sources, a total of \$18,780,000. These expenditures do not include sewers and small drains. The improvements were principally storm drains.

45. *City of Los Angeles.*—Prior to 1933 the city had constructed about 522 miles of storm drains within its limits at a cost of about \$26,900,000, entirely from local funds. About 85 percent of this work was done between 1923 and 1933. From 1933 to 1935 the city spent about \$4,500,000, of which about \$600,000 was from local funds and \$3,900,000 from the Reconstruction Finance Corporation, the Civil Works Administration, the State Emergency Relief Administration, and the Los Angeles County Relief Administration. The State and county were the major contributors, with a total contribution of about \$2,300,000. From October 1935 to January 1940 the city has spent about \$1,900,000 in sponsoring Work Projects Administration construction entailing an expenditure of about \$20,800,000 of Federal money. The city has therefore expended about \$29,400,000 of local money and \$24,700,000 from other sources, a total of \$54,100,000.

46. *Other cities.*—The cities of Glendale, Pasadena, and Long Beach have records of expenditures for similar work totaling about \$2,200,000 from local funds prior to about 1933. The other smaller towns have also expended appreciable sums, records of which are not available at this time. There are also no records available of expenditures for emergency relief work prior to the establishment of the Work Projects Administration in 1935, but, up to January 1940, the smaller cities in this basin have spent about \$1,000,000 sponsoring Work Projects Administration construction which has entailed an expenditure of about \$4,700,000 of Federal money. The three cities and the smaller towns of the basin are therefore accredited with an expenditure of \$3,200,000 of local funds and \$4,700,000 of Federal

funds, a total of \$7,900,000, and there have been appreciable additional expenditures of which there are no records available.

47. *Federal agencies.*—The Federal Government has participated from time to time in the planning and construction of improvements for flood control in the area, or in improvements partly relating to flood control. Prior to 1935 such participation was in connection with improvements for navigation.

48. In 1935, upon application by local interests, allotments of Federal funds were made under authority of the Emergency Relief Appropriation Act of April 8, 1935, for the construction of flood-control works consisting of storm drains, permanent channel improvements, debris basins, and one combination flood-control dam and debris-storage basin. Further allotments were made under subsequent acts for unemployment relief, and this work was continued by Federal agencies in cooperation with local interests. The principal Federal agencies involved were the War Department and the Work Projects Administration.

49. The following table includes data pertaining to the flood control projects supervised by the War Department in the area considered in this report. A number of these projects were later included in the existing project discussed in paragraphs 38 and 39.

*Cost of flood control improvements sponsored by War Department, Corps of Engineers, authorized by the Emergency Relief Act of April 8, 1935, and subsequent emergency relief acts—Federal costs are those prior to existing project*

| Project and stream                                  | Total Federal cost | Local contributed funds <sup>1</sup> |
|-----------------------------------------------------|--------------------|--------------------------------------|
| <b>LOS ANGELES RIVER</b>                            |                    |                                      |
| Los Angeles River Channel:                          |                    |                                      |
| Section 14-A (Randolph St. to Stewart and Gray Rd.) | \$1,257,819.96     | \$7,041.68                           |
| Section 29 (Lankershim to Fletcher)                 | 2,126,747.46       | 70,608.09                            |
| Fletcher to Dayton                                  | 82,280.82          |                                      |
| Haines Canyon, channel and debris basin             | 682,294.24         | 148,711.52                           |
| Dunsmuir Canyon, channel and debris basin           | 456,728.22         | 116,628.76                           |
| Shields Canyon, channel and debris basin            | 119,117.68         | 30,421.88                            |
| Eagle-Goss Canyons, channel and debris basin        | 496,632.86         | 128,854.99                           |
| Snover-Weber Canyons, channel and debris basin      | 207,429.07         | 52,981.42                            |
| Verdugo Wash, channel (below upper Canada Bridge)   | 1,783,594.55       | 1,515,460.04                         |
| Sycamore Wash, channel                              | 194,696.05         |                                      |
| Hay and Winery Canyon, channel and debris basin     | 346,134.71         | 88,891.08                            |
| Compton Creek, channel                              | 949,908.93         | 628,225.72                           |
| Long Beach, northeast drainage system               | 238,803.82         | 61,245.23                            |
| <b>RIO HONDO</b>                                    |                    |                                      |
| Eaton Canyon, flood control and debris basin        | 551,140.50         | 423,082.31                           |
| Rubio Wash, channel                                 | 926,048.23         | 321,867.45                           |
| Alhambra Wash, channel                              | 1,076,682.45       | 374,393.48                           |
| <b>BALLONA CREEK</b>                                |                    |                                      |
| Ballona Creek, channel                              | 4,161,010.84       | 1,087,391.10                         |
| Arroyo de los Jardines, storm drain                 | 206,872.22         | 32,993.35                            |
| Total                                               | 15,763,942.61      | 4,976,296.08                         |

<sup>1</sup> Does not include cost of rights-of-way. Includes all local contributed funds to Mar. 1, 1939. Of the total, \$3,971,955.46 was contributed to the relief projects and \$1,004,340.62 was contributed to the existing project.

50. *Summary.*—Approximately \$203,000,000 has thus been expended in these basins for protection from floods and storm waters, by means of flood-control works and storm drains, and to a minor extent for water conservation which appears as a small part of the expenditure

22 LOS ANGELES AND SAN GABRIEL RIVERS AND BALLONA CREEK, CALIF.

of the Los Angeles County Flood Control District. Approximate estimates of the costs to the various agencies are summarized in the following table:

*Cost of flood control and storm drain improvements in the basins of Los Angeles and San Gabriel Rivers and Ballona Creek to Jan. 1, 1940*

| Agency                                         | Amount and source of expenditures |                              |                                                  |              |
|------------------------------------------------|-----------------------------------|------------------------------|--------------------------------------------------|--------------|
|                                                | Local                             | Work Projects Administration | Other Federal, State, and county relief agencies | Total        |
| United States Engineer Department:             |                                   |                              |                                                  |              |
| Relief projects prior to existing project..... |                                   |                              |                                                  | \$15,800,000 |
| Existing project.....                          |                                   |                              |                                                  | 37,500,000   |
| Total U. S. Engineer Department.....           |                                   |                              |                                                  | 53,300,000   |
| Los Angeles County Flood Control District..... | \$68,800,000                      | \$500,000                    |                                                  | 69,300,000   |
| City of Los Angeles.....                       | 29,400,000                        | 20,800,000                   | \$3,800,000                                      | 54,000,000   |
| Los Angeles County engineer's office.....      | 8,000,000                         | 10,400,000                   | 400,000                                          | 18,800,000   |
| Other cities and towns (not complete).....     | 3,200,000                         | 4,700,000                    |                                                  | 7,900,000    |
| Total.....                                     | 109,400,000                       | 30,400,000                   | 4,300,000                                        | 203,400,000  |

IMPROVEMENTS DESIRED

51. On March 31, 1936, a public hearing was held at Los Angeles to ascertain the extent and character of flood-control improvements desired by local interests. This hearing was attended by about 150 persons, including officials of Federal agencies, the city of Los Angeles, the county of Los Angeles, the Los Angeles County Flood Control District, and various civic organizations, as well as by the general public. Concerning flood control, the hearing disclosed that local interests desire protection from floods in the drainage basins of Los Angeles and San Gabriel Rivers and Ballona Creek by the construction of adequate channel improvements, flood-control basins, and debris basins. They request that, where practicable, water conservation be coordinated with flood control.

52. Local interests believe that numerous areas, some of which are highly developed, will be left unprotected from floods after the completion of the works now authorized. The extent and character of specific measures for flood control were outlined briefly by local interests at the hearing. Local interests' revised general plan includes 54 items which they estimate will cost approximately \$237,000,000. These items have been considered in the preparation of the plan of improvement recommended in this report. (See enclosures 7 and 8.)<sup>1</sup>

FACTORS CONSIDERED

53. *Precipitation and run-off.*—Precipitation at Los Angeles has been recorded by the United States Weather Bureau since 1877. Between 1877 and 1917, the records within the area considered in this report were restricted to coastal plain, valley, and foothill stations with the exception of the records at Echo Mountain, Colby Ranch, and Mount Wilson, which have been kept since 1895, 1897, and 1904,

<sup>1</sup> Not printed.

respectively. Since 1917, the number of precipitation stations has increased until records are now regularly maintained at more than 300 stations, of which 125 are in the mountainous areas. Automatic recording rain gages have been installed at 59 stations.

54. An extensive study of rainfall was made by using all available precipitation data from stations within and in the vicinity of the area, and in addition the long-term records for San Diego, Santa Barbara, and Sacramento. Enclosure 6<sup>1</sup> gives the basic rainfall data, the methods of analysis, and estimates of flood flows. The 64-year mean seasonal precipitation for the period 1872 to 1936 was computed for key stations, which are shown on an isohyetal map, exhibit 17, enclosure 6.<sup>1</sup> The mean annual precipitation is approximately 13.5 inches on the coastal plain, 18 inches in the valleys and foothills, and 28 inches in the mountains.

55. The location of the mountainous sections of the drainage basins, with reference to the general direction in which storms advance, has resulted in very high maximum precipitation intensities. A maximum intensity of 1.03 inches per minute has been recorded at Opid's Camp in the San Gabriel Mountains. Recorded daily maxima for the coastal plain, foothill, and mountain areas are, respectively, 5.88 inches (Los Angeles), 8.50 inches (Glendora), and 17.55 inches (Kelly's Camp). The maximum rainfall of 62.9 inches for a calendar year was recorded at Glendora in 1884. The maximum rainfall of 89.33 inches for the water-year occurred at Opid's Camp during the year ending in the summer of 1922.

56. In 1895, the United States Geological Survey began recording run-off from the mountainous area of the San Gabriel River Basin. Additional gaging stations were subsequently installed, and since 1917, discharge records for many mountain streams in the area have been obtained by both the United States Geological Survey and the Los Angeles County Flood Control District. More recent records and single measurements have been obtained at scattered points along the main stream channels in the valleys and coastal plain. The gaging stations are located and listed in enclosure 6.<sup>1</sup>

57. Unfortunately the run-off data obtained from stream gages do not include records of great floods. It was, therefore, necessary to investigate rainfall-run-off relations and develop flood hydrographs by other means, with the available run-off data for guidance. (See enclosure 6.<sup>1</sup>)

58. *Flood records.*—A history of floods in southern California has been compiled for the period 1811–1938, inclusive. This record indicates that at least 21 destructive floods have occurred during the 128-year period. A brief history of these floods, including the recent destructive flood of March 1938, is presented in enclosure 5.<sup>1</sup>

59. The magnitude of the respective floods is not known except that of the March 1938 flood. The magnitude of some of the earlier floods has been estimated by local interests from channel profiles, observed high-water marks, and the use of Kutter's formula. (See table, par. 62.) The approximate magnitude of other past floods was estimated from the historical description of the respective floods, rainfall indices when available, and by noting whether the magnitude of a given flood appeared to be greater or less than that of the floods of which the approximate magnitude was known.

<sup>1</sup> Not printed.



24 LOS ANGELES AND SAN GABRIEL RIVERS AND BALLONA CREEK, CALIF.

60. During the flood of 1815, the Los Angeles River changed its course from the general location of its present channel by turning west in the vicinity of what is now downtown Los Angeles and flowing into the ocean by way of the present Ballona Creek. Ten years later, the flood of 1825 caused the stream to return to its original southerly course. Since then numerous minor changes have occurred in the channel alinement, but in general the stream has held continuously to its present course, even during the great flood of the winter of 1861-62 which appears to have been the greatest of record. This flood caused extensive damage along all streams and their tributaries in the area under consideration.

61. Stream-gaging stations have been maintained for many years by the United States Geological Survey and by the Los Angeles County Flood Control District. During large floods, however, all the main-stream stations have been either destroyed or damaged to an extent that an authentic record of the flood could not be made. All information recorded concerning the magnitudes of the larger floods has been based upon surveys of the stream channels after each flood and upon the river stages as indicated by the location of drift or other high-water marks. Occasionally observations of floating objects were made from which stream velocity was estimated.

62. All available estimates of flood discharges at points along the main channels of three of the major streams in the area are given in the following table:

*Flood discharges of the Los Angeles and San Gabriel Rivers and the Rio Hondo*

| Location                                       | River mile | Drainage area<br>Sq. mi. | Crest flow (cubic feet per second) |        |        |        |        |        |
|------------------------------------------------|------------|--------------------------|------------------------------------|--------|--------|--------|--------|--------|
|                                                |            |                          | 1889                               | 1914   | 1916   | 1927   | 1934   | 1938   |
| <b>Los Angeles River:</b>                      |            |                          |                                    |        |        |        |        |        |
| Lankershim Blvd. Bridge.....                   | 38.1       | 401                      |                                    | 16,780 |        |        |        |        |
| Dayton Ave.....                                | 24.0       | 504                      |                                    |        |        |        |        | 67,000 |
| Below Main St. Bridge.....                     | 23.0       | 500                      |                                    | 31,140 |        |        |        |        |
| Southern Pacific R. R. bridge.....             | 22.6       | 565                      | 38,000                             |        |        |        |        |        |
| Stewart and Gray Rd.....                       | 13.0       | 610                      |                                    |        |        |        | 29,400 | 63,000 |
| Below mouth of Rio Hondo.....                  | 12.0       | 747                      |                                    |        |        |        | 44,000 | 75,000 |
| Willow St., Long Beach.....                    | 3.0        | 818                      |                                    |        |        | 51,200 |        |        |
| State St., Long Beach.....                     | 1.7        | 818                      |                                    |        |        |        |        | 99,100 |
| <b>San Gabriel River:</b>                      |            |                          |                                    |        |        |        |        |        |
| Near Azusa.....                                | 38.0       | 214                      |                                    |        | 40,000 |        | 18,000 |        |
| 2 miles above mouth of San Gabriel Canyon..... | 37.0       | 216                      |                                    | 25,260 |        |        |        | 58,000 |
| Below mouth of Roberts Canyon.....             | 35.0       | 220                      | 47,000                             | 26,680 |        |        |        | 43,000 |
| Below Whittier Blvd. Bridge.....               | 18.1       | 450                      |                                    | 16,000 |        |        |        | 40,000 |
| <b>Rio Hondo:</b>                              |            |                          |                                    |        |        |        |        |        |
| Below Downey Rd.....                           | 3.5        | 130                      |                                    | 20,930 |        |        |        | 30,000 |
| Stewart and Gray Rd.....                       | 1.2        | 137                      |                                    |        |        |        | 16,000 | 24,000 |

<sup>1</sup> Report of the Board of Engineers, flood control, to the Board of Supervisors of Los Angeles County, Calif., submitted July 26, 1915.

<sup>2</sup> Report on engineering aspects, flood of March 1938, U. S. Engineer Office, Los Angeles, Calif., August 1938.

<sup>3</sup> Data from the Los Angeles County Flood Control District.

<sup>4</sup> Bulletin No. 6, San Gabriel Investigations, Department of Public Works, State of California, Sept. 30, 1938.

<sup>5</sup> Water Supply Paper No. 766, U. S. Geological Survey, 1934.

63. Floods in Ballona Creek and its tributaries have occurred simultaneously with floods on the Los Angeles River. As has been stated, during the flood of 1815 the Los Angeles River broke through the low divide between the two basins and flowed to the ocean via Ballona Creek. This course was maintained until the flood of 1825

when the Los Angeles River returned to its original channel. Following that period the main channel of Ballona Creek was successively altered by natural erosion, industrial and residential development, and finally by improvement for flood control which was practically completed in 1937. Flood discharges prior to the improvement were not measured, and such estimates as have been made are of little value since they would not indicate the flood crests that may be expected from a given rainfall under present conditions of improved channels. Discharge measurements in the improved channel at Sawtelle Boulevard were obtained during the flood of March 1938, from which a crest flow of 19,200 cubic feet per second was computed.

64. The establishment of gage heights or elevations marking definite flood stages in natural stream channels of the Los Angeles area is extremely difficult. The streams from the mountain areas flow across the alluvial plain in unstable channels, changing their courses frequently in the process of building up the debris cones. In the main channels, flood discharges alter the channel cross sections to such an extent that any relation between stage and discharge which might have been established is soon destroyed.

65. *Flood frequencies.*—Knowledge concerning all the natural factors governing flood occurrences is insufficient to permit accurate predictions of the number of future floods and their corresponding magnitudes. Therefore, the probability of future flood occurrences can be estimated only from a history of past floods, giving due consideration to the possible synchronization of meteorological conditions which would cause floods exceeding those of record. Consequently, for purposes of economic investigation, the probable frequency and relative magnitude of future floods, as given in the following table, are based on the history of past floods.

*Estimated frequency of floods in the basins of the Los Angeles and San Gabriel Rivers and Ballona Creek*

| Character of flood                                                                                                                                                                                       | Number of occurrences in 100 years |
|----------------------------------------------------------------------------------------------------------------------------------------------------------------------------------------------------------|------------------------------------|
| Great floods, approaching the probable maximum, covering the entire flood plain in the valleys and extensive areas in the Coastal Plain; causing great damage to property and considerable loss of life. | 1                                  |
| Large floods from general storms, inundating all low-lying valley areas and sections of the Coastal Plain adjacent to the stream channels, causing heavy damage and possible loss of life.               | 6                                  |
| Moderate floods, causing overflow and damage to marginal land along main streams and principal tributaries.                                                                                              | 10                                 |

66. *Extent and character of area subject to floods.*—The probable overflow area is outlined on map 2<sup>1</sup> of enclosure 1. This area would not be completely flooded by the run-off from any one storm, including the design storm, but because of instability of the natural channels and the relative freedom of flood flows to follow various courses over the debris cones and through the alluvial valleys, the whole area has been and would be damaged one or more times. The total of approximately 325,000 acres within the overflow area is divided among the major stream basins as follows: Los Angeles River Basin, 130,000

<sup>1</sup> Not printed.

acres; San Gabriel River Basin, 140,000 acres; Rio Hondo Basin 30,000 acres; and Ballona Creek Basin, 25,000 acres. The division of overflow areas among the several basins along their common watersheds is arbitrary, since waters from all the major streams have intermingled during past floods and formed a veritable lake on the Coastal Plain before emptying into the ocean. The present value of land and improvements of the entire overflow area as defined in this report is estimated at more than \$1,000,000,000. For various reasons, certain small overflow areas are not included in the total. Enclosure 13<sup>1</sup> gives estimates of the value of the individual overflow areas.

67. The number of persons residing in the overflow area is estimated at 800,000. No estimate has been made of the number in each of the separate overflow areas of the various basins. A major flood would seriously affect not only those people but everyone within the Los Angeles metropolitan area because of the interruption of industry, power, light, water, and transportation facilities. Due to the large residential areas in the basin being widely separated from the places of business and employment of the inhabitants, the disruption of normal business activity, due to floods which prevent intercommunication, is very serious.

68. In the upper reaches of the Los Angeles River Basin, the overflow area consists mainly of farm land used for growing of citrus fruits, olives, garden truck, and some grain. Many towns in the upper valleys and in the foothills are within the overflow area and subject to extensive damage from debris flows. Large areas in the cities of Burbank and Glendale are exposed to the flood menace, and immediately below, in the flood plain of the Los Angeles River, there are major industrial developments and a large part of the residential and business areas of Los Angeles. The overflow area below Los Angeles includes the towns of Huntington Park, South Gate, Compton, and a portion of the city of Long Beach, as well as agricultural areas, oil fields, and oil refineries. The present value of the overflow area in the Los Angeles River Basin has been estimated at \$747,000,000.

69. The upper portion of the overflow area in the San Gabriel River Basin consists principally of highly developed citrus groves. These are representative of extremely valuable agricultural lands and are valued as high as \$3,000 an acre. There are several agricultural communities but no large towns in the upper portion of the overflow area. Below Whittier Narrows the area subject to floods includes small towns, truck farms, and petroleum tank farms and refineries. Three highly productive oil fields are affected, the entire extent of one field being within the flood plain. The towns of Bellflower, Artesia, Norwalk, and a portion of the city of Long Beach are in this flood zone. The present value of the overflow area of the San Gabriel River Basin is estimated at \$113,000,000.

70. The entire eastern section of the city of Pasadena is subject to flood damage from Eaton and Rubio Washes, tributaries of the Rio Hondo. Other cities and towns affected by floods on the Rio Hondo tributaries are Sierra Madre, Arcadia, Monrovia, San Gabriel, and Alhambra. Outside of the urban and suburban areas, the flood plain of the Rio Hondo is developed into citrus groves and small farms.

<sup>1</sup> Not printed.

The overflow area between the Rio Hondo and the San Gabriel River includes the town of El Monte and several small agricultural communities. Population data for the Rio Hondo flood zone are not available. The present value of the Rio Hondo overflow area is estimated at \$85,000,000.

71. Nearly all of the Ballona Creek overflow area is occupied by residential and industrial development. In Los Angeles, Beverly Hills, and Culver City (in Ballona Creek Basin) some of the finest homes in the metropolitan area are affected by recurrent flooding. A small part of the southern portion of the area is occupied by truck farms and by wells of the Baldwin Hills oil field. The present value of the overflow area in Ballona Creek Basin is estimated at \$103,000,000.

72. *Damage from past floods.*—Only meager data concerning the extent of the damage from past floods are available. Except for the 1938 flood, these data cover damages in the general area and are not susceptible of apportionment applicable to the separate river basins. The damages from early floods were low due to the undeveloped character of the country at the time of their occurrence. (See par. 16.) Quantitative estimates have been made in only five instances, a brief summary of which follows:

*Estimated damage from past floods, basins of the Los Angeles and San Gabriel Rivers and Ballona Creek*

| Flood year | Authority                                     | Estimated damage (value at time of flood) | Lives lost |
|------------|-----------------------------------------------|-------------------------------------------|------------|
| 1884       | Los Angeles Express, Feb. 18, 1884            | \$1,000,000                               | (1)        |
| 1889       | Los Angeles Herald, December 1889             | 398,700                                   | (1)        |
| 1914       | J. W. Reagan, chairman, board on flood damage | 10,000,000                                | (1)        |
| 1934       | Los Angeles County Flood Control District     | 6,082,300                                 | 41         |
| 1938       | U. S. Engineer Office, Los Angeles:           |                                           |            |
|            | Los Angeles River Basin                       | 25,500,000                                | 43         |
|            | Rio Hondo Basin                               | 3,100,000                                 | 2          |
|            | San Gabriel River Basin                       | 10,500,000                                | 1          |
|            | Ballona Creek Basin                           | 1,300,000                                 | 3          |
|            | Total, 1938                                   | 40,400,000                                | 49         |

<sup>1</sup> None reported.

73. *Damage from future floods.*—Damages from future floods depend on the frequency and severity of flooding and on the existing and future development of the area within the flood plain. The frequency of future floods of various magnitudes has been determined on the basis of past experience and is tabulated in paragraph 65. The damage which most probably would be caused by each flood is estimated on the basis of the present values in the areas involved and the estimated future growth that would occur without flood control. The following table summarizes the probable future damage from all floods within a period of 50 years, which would be prevented by improvements recommended in the general plan. Details of the estimate are given in enclosure 13.<sup>1</sup>

<sup>1</sup> Not printed.

28 LOS ANGELES AND SAN GABRIEL RIVERS AND BALLONA CREEK, CALIF.

*Estimated damage from future floods, basins of the Los Angeles and San Gabriel Rivers and Ballona Creek*

[50-year period]

| Drainage basin         | Estimated damage |                 | Total damage    |
|------------------------|------------------|-----------------|-----------------|
|                        | Direct           | Indirect        |                 |
| Los Angeles River..... | \$366, 074, 400  | \$219, 581, 200 | \$585, 655, 600 |
| San Gabriel River..... | 133, 369, 000    | 80, 034, 000    | 213, 403, 000   |
| Rio Hondo.....         | 42, 187, 000     | 25, 321, 000    | 67, 508, 000    |
| Ballona Creek.....     | 44, 560, 000     | 26, 736, 000    | 71, 296, 000    |
| Total.....             | 586, 190, 400    | 351, 672, 200   | 937, 862, 600   |
| Say.....               | 586, 200, 000    | 351, 700, 000   | 938, 000, 000   |

74. *Water supply and conservation.*—In nearly all southern California, irrigation is essential to successful agriculture. Since part of the domestic water supply and almost all the water used for irrigation is now obtained by pumping from underground, it is necessary to prevent a lowering of the underground water plane so that pumping will continue to be economical and, near the coast, to prevent intrusion of salt water. In some areas overpumping has lowered the ground water to depths below sea level and as a result salt water intrusion has damaged the underground water supply.

75. About 30 years ago the city of Los Angeles found that the demand for water exceeded the local supply, and in order to permit continued development, constructed the Los Angeles-Owens Valley aqueduct system. Placed in service in 1913, this aqueduct, with an ultimate capacity of 450 cubic feet per second, transports water from Owens Valley at the foot of the Sierra Nevada Mountains in east-central California to Los Angeles, a distance of about 250 miles. Present (1939) estimates by local interests indicate that a quantity double the present supply will be required in the near future for use in the Los Angeles area. To provide for future requirements in this and adjoining areas, the Metropolitan Water District of Southern California is now constructing the Colorado River aqueduct which will have an ultimate capacity of 1,500 cubic feet per second, and which will transport water from the Colorado River, a distance of about 300 miles.

76. Various methods of water conservation have been investigated. Because of the characteristics of the rainfall, the high silt content of the flood flows, and the scarcity of suitable reservoir sites, relatively few water conservation reservoirs have been built. However, the spreading of water over porous soil to cause increased percolation to the underground storage basins has been highly developed. Debris and retarding basins permit percolation of a portion of the flow, and local flood control dams have been operated, when practicable, so that the outflow does not exceed the rate of percolation of the water-spreading grounds. Enclosure concerning water conservation was submitted with preliminary examination report dated April 23, 1938.

77. *Water rights.*—The water supply of various local underground basins is considerably augmented by surface storage facilities and diversions to spreading grounds constructed for that purpose. Modification of run-off and the natural disposal of stream flow by growth and development in the area has further affected the available supplies. Due to inadequacy of the local water supply to meet all the require-

ments of the area, there has been a continual and intense struggle for its use and development. Consequently, the local problem of water rights is very important and must be considered in connection with plans for flood-control improvements.

78. *Water power.*—Typical of all southern California, the dry season in the Los Angeles County area extends over half of each year, and dry cycles lasting for a number of years are not uncommon. The mountain slopes are precipitous, with thin soil and sparse growth, and consequently the run-off is practically completed soon after each flood-producing storm. Reservoir sites of sufficient capacity to provide storage for continuous water-power operation are lacking, and there are only a few water-power plants within the basin operating from local water supplies. The area is now supplied with electricity from municipal, Federal (Boulder Dam), and private plants, the reserves of which appear to be sufficient to supply the needs for a considerable time to come. Therefore, the development of power from local water supplies is considered infeasible.

79. There are several water-power plants in the basin operated by the Los Angeles Bureau of Water and Power with water conveyed by the Los Angeles-Owens Valley aqueduct. Three of these plants are the San Fernando power plant, at the southern terminus of the aqueduct; the River power plant, at Coldwater Avenue on the Los Angeles River near Van Nuys; and the Franklin power plant, located between the upper and lower Franklin Canyon Reservoirs.

80. *Miscellaneous factors.*—The type of flood-control improvements adaptable to the area offers no possibilities for direct coordination with navigation interests except in connection with the Alamitos Bay separation. Indirect benefits will accrue in connection with the proposed improvements at the mouth of the San Gabriel River, through control of silt deposits and the provision of more satisfactory navigation facilities in Alamitos Bay. Only the flood-control benefits in this case are taken into account in the economic analysis of the flood control works given in enclosure 13.<sup>1</sup> The matter of terminal facilities has no connection with flood-control improvements in this area.

81. Concerning section 5 of the River and Harbor Act of August 30, 1935, the desired flood-control improvements will have some effect on beach erosion at the mouths of the streams under consideration. The control of floodwaters in the upland areas will reduce the sand supply from that source and ultimately result in some depletion of the beaches near their estuaries, since the amount of natural beach erosion would probably exceed the sand supplied by the improved streams. A special investigation by the Shore Protection Board does not appear to be necessary at the present time, but it may be found desirable to include the matter in future beach erosion studies. Such study has been requested by local interests.

#### FIELD WORK

82. Prior to the authorization of this report, considerable information in connection with design studies and construction activities had been collected by this office, as follows:

(a) Complete data showing alignment, profiles, and cross sections for the major channel improvements investigated.

<sup>1</sup> Not printed.

(b) Special topographic maps of congested sections, aerial photographs of large areas, and complete sets of United States Geological Survey quadrangle maps.

(c) Data obtained by the Los Angeles County Flood Control District by extensive field surveys made in connection with flood control studies.

(d) Data from the Metropolitan Water District, city engineers of various municipalities in Los Angeles County, the Los Angeles County surveyor, and other local agencies.

83. All the above agencies were generous in their cooperation in making data available to this office.

84. During the progress of the studies and designs made for this report, additional field information was obtained as needed. Field reconnaissance was made to check the location and design of flood-control improvements considered for areas where new residential and industrial developments had rendered previous data obsolete. Supplemental aerial photographs were also obtained where needed detailed information was lacking or where changes had occurred. Field surveys were made at critical points in the alignment or grade of the more important project units.

#### PLAN OF IMPROVEMENT.

85. *General.*—According to testimony originally presented at the public hearing and later substantiated and expanded, local interests desire flood-control improvements to provide protection for all localities now subject to flood damage. Various local interests have presented plans of improvement, partial or complete, in accordance with the extent of the interests involved. All plans submitted have been given careful consideration in the analysis of the general flood problem with a view to developing a general plan that would provide adequate permanent works to operate interdependently in controlling the runoff resulting from a storm of the severity of the estimated design storm. In developing the general plan, complete hydrology studies were made, taking into account all available data. The detailed discussion of the hydrology and the development of the design storm and discharges are presented in enclosure 6.<sup>1</sup> The maximum 24-hour rainfall of the 4-day design storm varies from 3 inches near the coast to 16 inches in mountains and was assumed to occur on the fourth day of the storm. The rainfall for the first 3 days of the 4-day design storm was assumed to be 20, 30, and 50 percent, respectively, of the fourth day's rainfall.

86. The existing project (see par. 38) embraces the major streams in the area under consideration and is the basis of the general plan. To the framework of the existing project have been added items of improvement necessary for the protection of the tributary areas and which have been found by economic analysis to warrant immediate development. Thus the general plan consists of all existing project items and all extensions that are economically justified at this time. Consideration was also given the existing works along the main channels which could be safely included as a part of the general plan.

87. The general plan is shown on page 1 of enclosure 1, and detailed designs for the individual items are presented in enclosures 9<sup>1</sup> and 10.<sup>1</sup> The individual items are described in enclosure 7<sup>1</sup> and detailed cost estimates presented in enclosure 12.<sup>1</sup> A brief description of the general plan by basins with summarized costs is given in the following

<sup>1</sup> Not printed.

paragraphs. The design discharges are shown on exhibit 41 and peak discharges of the flood of March 1938 are indicated on exhibit 5, enclosure 6.<sup>1</sup> The items of the extension of the existing project with their costs are given in table, paragraph 96. The items of the existing project with their costs are given in table, paragraph 38. These two tables give all items of the general plan.

88. *Los Angeles River Basin.*—The items of major importance in the general plan in the drainage basin of the Los Angeles River are the proposed Sepulveda, Lopez, and Hansen flood-control basins. These flood-control basins are located in San Fernando Valley and will minimize the flood menace in the agricultural and residential communities of the Tujunga Wash and lower San Fernando Valley areas, and reduce the probable maximum flood run-off from the valley to the feasible capacity of an improved Los Angeles River main-stream channel to the ocean. The Sepulveda and Hansen flood-control basins are a part of the existing project and are now under construction by the Corps of Engineers.

89. In addition to the three flood-control basins mentioned above, the general plan of improvements on Los Angeles River and tributaries, including works covered in the existing project, consists of debris basins at the mouths of 17 tributary canyons, 49.07 miles of main channel of Los Angeles River, tributary channels having an aggregate length of 53.42 miles, 43 bridges over the main channel of Los Angeles River, and 66 bridges over the tributary channels.

90. *San Gabriel River Basin.*—In the general plan of proposed flood-control improvements in the drainage basin of San Gabriel River, the Santa Fe and Whittier Narrows flood-control basins are the most important. These basins are designed to reduce peak flows of San Gabriel River so as to permit channel improvements to the ocean to be held within economical limits and at the same time provide adequate protection from floods. The Whittier Narrows flood-control basin will reduce the flow in the Rio Hondo Channel so that additional channel work on Rio Hondo will not be necessary. The Santa Fe flood-control basin and the channel from the basin to the mouth of the canyon are included in the existing project.

91. In addition to the above-mentioned flood-control basins, the general plan of improvements on San Gabriel River and its tributaries, including the items covered in the existing project, consists of debris basins at the mouths of 7 tributary canyons, 35.60 miles of main channel of San Gabriel River, tributary channels having an aggregate length of 69.16 miles, 10 bridges over the main channel of San Gabriel River, and 132 bridges over the tributary channels.

92. *Rio Hondo Basin.*—The general plan of improvements recommended for flood control in the Rio Hondo Basin, including Alhambra Wash Channel, an item of the existing project, consists of debris basins at the mouths of 7 tributary canyons, 9.76 miles of main channel, an aggregate length of 35.23 miles of tributary channels, 6 bridges over the main channel, and 59 bridges over the tributary channels.

93. *Ballona Creek Basin.*—Ballona Creek drains a densely populated and highly developed urban area which includes Culver City and the southwestern part of the city of Los Angeles. The lower part of the main stream is but slightly above sea level and has a very low gradient. The tributaries to the north have steeper gradients and drain

<sup>1</sup> Not printed.



32 LOS ANGELES AND SAN GABRIEL RIVERS AND BALLONA CREEK, CALIF.

the south slope of the Santa Monica Mountains and flow about 5 miles southerly through highly developed residential districts to Ballona Creek.

94. The general plan of flood-control improvements recommended in the drainage basin of Ballona Creek, including Ballona Creek main channel and jetties, items of the existing project, consists of debris basins at two tributary canyon mouths, 2.39 miles of main channel an aggregate length of 23.67 miles of tributary channels, 4 bridges over the main channel, and 8 bridges over the tributary channels.

95. *Summary.*—The type of improvements included in the general plan are summarized in the following table:

*General plan of improvement of the Los Angeles and San Gabriel Rivers and their tributaries, and Ballona Creek*

| Drainage basin         | Flood-control basins | Debris basins | Channel, miles |            | Bridges, number |            |
|------------------------|----------------------|---------------|----------------|------------|-----------------|------------|
|                        |                      |               | Main stream    | Tribu-tary | Main stream     | Tribu-tary |
| Los Angeles River..... | 3                    | 17            | 49.07          | 53.42      | 43              | 66         |
| San Gabriel River..... | 2                    | 7             | 35.60          | 69.16      | 10              | 132        |
| Rio Hondo.....         |                      | 7             | 9.76           | 35.23      | 6               | 59         |
| Ballona Creek.....     |                      | 2             | 2.39           | 23.67      | 4               | 8          |
| Total.....             | 5                    | 33            | 96.82          | 181.48     | 63              | 265        |

96. The estimated cost of the work covered in the general plan, including estimates of the existing project, is given in the following tables:

*General plan for flood control (existing project plus extensions), Los Angeles and San Gabriel Rivers and their tributaries, and Ballona Creek, Calif.—Estimated costs*

LOS ANGELES RIVER BASIN

|                                                |                 |
|------------------------------------------------|-----------------|
| Existing project: (See table, par. 38).....    | \$67, 282, 673  |
| Recommended extension:                         |                 |
| Los Angeles River Channel:                     |                 |
| Owensmouth Ave. to Niagara St.....             | \$15, 926, 000  |
| Los Angeles River Channel:                     |                 |
| Stewart and Gray Rd. to Pacific Ocean.....     | 18, 933, 000    |
| Lopez flood-control basin.....                 | 4, 779, 000     |
| Caballero Creek.....                           | 1, 372, 750     |
| Wilson Canyon and Mansfield St. Channel.....   | 2, 377, 700     |
| Lopez Canyon diversion.....                    | 301, 900        |
| Pacoima wash channel.....                      | 2, 641, 000     |
| Blue Gum Canyon.....                           | 106, 550        |
| Tujunga wash channel.....                      | 7, 748, 000     |
| Burbank western system.....                    | 6, 280, 000     |
| Burbank eastern system.....                    | 7, 661, 000     |
| Blanchard Channel.....                         | 255, 700        |
| Verdugo wash (U. C. Br. to debris basin).....  | 1, 092, 000     |
| Dead Horse Canyon and Royal Blvd. Channel..... | 404, 000        |
| Winery Canyon.....                             | 497, 300        |
| Compton Creek.....                             | 1, 467, 000     |
| Subtotal.....                                  | 71, 842, 900    |
| Total for Los Angeles River Basin.....         | \$139, 125, 573 |

LOS ANGELES AND SAN GABRIEL RIVERS AND BALLONA CREEK, CALIF. 33

General plan for flood control (existing project plus extensions), Los Angeles and San Gabriel Rivers and their tributaries, and Ballona Creek, Calif.—Estimated costs—Continued

SAN GABRIEL RIVER BASIN

|                                                                                                      |                |                |
|------------------------------------------------------------------------------------------------------|----------------|----------------|
| Existing project: (See table, par. 38).....                                                          |                | \$12, 103, 000 |
| Recommended extension:                                                                               |                |                |
| Whittier Narrows flood-control basin.....                                                            | \$16, 983, 000 |                |
| San Gabriel River Channel: Santa Fe flood-control basin to Whittier Narrows flood-control basin..... | 4, 211, 000    |                |
| San Gabriel River Channel: Whittier Narrows flood-control basin to Pacific Ocean.....                | 10, 116, 000   |                |
| Anaheim Bay Bypass.....                                                                              | 972, 000       |                |
| Jetty extension and Alamitos Bay separation.....                                                     | 996, 000       |                |
| Walnut Creek system.....                                                                             | 21, 943, 900   |                |
| Walnut Creek Inlet Channel.....                                                                      | 2, 468, 000    |                |
| Marshall Creek.....                                                                                  | 915, 500       |                |
| Emerald wash and Liveoak wash.....                                                                   | 1, 871, 000    |                |
| Thompson Creek and San Jose wash.....                                                                | 3, 797, 900    |                |
| Coyote Creek.....                                                                                    | 9, 851, 000    |                |
| Subtotal.....                                                                                        | 74, 125, 300   |                |
| Total for San Gabriel River Basin.....                                                               |                | \$86, 228, 300 |

RIO HONDO BASIN

|                                                                              |               |               |
|------------------------------------------------------------------------------|---------------|---------------|
| Existing project: (See table, par. 38).....                                  |               | \$1, 205, 613 |
| Recommended extension:                                                       |               |               |
| Rio Hondo Channel: Santa Fe Ry. to Whittier Narrows flood-control basin..... | \$5, 349, 000 |               |
| Sawpit wash.....                                                             | 2, 084, 200   |               |
| Sierra Madre Villa Channel.....                                              | 498, 900      |               |
| Santa Anita wash.....                                                        | 4, 321, 000   |               |
| Arcadia wash system.....                                                     | 4, 717, 500   |               |
| Rubio Canyon diversion.....                                                  | 946, 000      |               |
| Eaton wash.....                                                              | 3, 462, 000   |               |
| Subtotal.....                                                                | 21, 378, 600  |               |
| Total for Rio Hondo Basin.....                                               |               | 22, 584, 213  |

BALLONA CREEK BASIN

|                                             |               |               |
|---------------------------------------------|---------------|---------------|
| Existing project: (See table, par. 38)..... |               | \$1, 950, 100 |
| Recommended extension:                      |               |               |
| Higgins and Coldwater Canyon.....           | \$4, 418, 000 |               |
| Benedict Canyon.....                        | 4, 680, 000   |               |
| Sawtelle-Westwood system.....               | 8, 225, 000   |               |
| Centinela Creek.....                        | 953, 500      |               |
| Subtotal.....                               | 18, 276, 500  |               |
| Total for Ballona Creek Basin.....          |               | 20, 226, 600  |
| Grand total for general plan.....           |               | 268, 164, 686 |

34 LOS ANGELES AND SAN GABRIEL RIVERS AND BALLONA CREEK, CALIF.

Cost summary of the general plan

[By basins]

|                              | Existing project | Recom-<br>mended ex-<br>tension | Total         |
|------------------------------|------------------|---------------------------------|---------------|
| Los Angeles River Basin..... | \$67,282,673     | \$71,842,900                    | \$139,125,573 |
| San Gabriel River Basin..... | 12,103,000       | 74,125,300                      | 86,228,300    |
| Rio Hondo Basin.....         | 1,205,613        | 21,378,600                      | 22,584,213    |
| Ballona Creek Basin.....     | 1,950,100        | 18,270,600                      | 20,220,600    |
| Total.....                   | 82,541,386       | 185,623,300                     | 268,164,686   |

Estimated cost of construction, utilities, bridges, and rights-of-way included in the general plan

| Drainage basin           | Construction  | Relocation<br>of public<br>utilities | Reconstruc-<br>tion of<br>bridges | Lands, ease-<br>ments, and<br>rights-of-way | Total         |
|--------------------------|---------------|--------------------------------------|-----------------------------------|---------------------------------------------|---------------|
| Los Angeles River.....   | \$114,482,490 | \$5,135,941                          | \$10,978,231                      | \$8,528,902                                 | \$139,125,573 |
| San Gabriel River.....   | 64,687,800    | 1,409,800                            | 8,725,700                         | 11,405,000                                  | 86,228,300    |
| Rio Hondo.....           | 18,310,886    | 179,702                              | 2,786,405                         | 1,307,220                                   | 22,584,213    |
| Ballona Creek.....       | 17,964,715    | 630,705                              | 609,041                           | 962,079                                     | 20,220,600    |
| Total <sup>1</sup> ..... | 215,445,900   | 7,356,208                            | 23,189,377                        | 22,203,201                                  | 268,164,686   |

<sup>1</sup> For the various units of the general plan, it was found impracticable to give the estimated cost in round figures due to complications arising in the make-up and use of component parts and the difficulty in checking calculations back through a multiplicity of figures.

In the preceding table the costs of construction, relocation of public utilities and bridges, lands, easements, and rights-of-way chargeable to the existing project total approximately \$82,540,000. The costs of the extension to the existing project are estimated as follows:

Estimated cost of improvements included in the extension of the existing project, Los Angeles and San Gabriel Rivers and Ballona Creek and their tributaries, after the completion of existing project

| Drainage basin         | Construc-<br>tion | Relocation<br>of public<br>utilities | Recon-<br>struction of<br>bridges | Lands, ease-<br>ments, and<br>rights-of-way | Total        |
|------------------------|-------------------|--------------------------------------|-----------------------------------|---------------------------------------------|--------------|
| Los Angeles River..... | \$57,171,300      | \$3,037,100                          | \$8,252,500                       | \$3,382,000                                 | \$71,842,900 |
| San Gabriel River..... | 64,068,800        | 1,347,800                            | 8,621,700                         | 10,187,000                                  | 74,125,300   |
| Rio Hondo.....         | 17,283,300        | 144,800                              | 2,724,500                         | 1,210,000                                   | 21,378,600   |
| Ballona Creek.....     | 16,912,500        | 530,600                              | 256,900                           | 567,500                                     | 18,270,600   |
| Total.....             | 145,445,900       | 5,066,300                            | 19,755,600                        | 15,352,500                                  | 185,623,300  |
| Say.....               | 146,000,000       | 5,000,000                            | 20,000,000                        | 15,000,000                                  | 186,000,000  |

<sup>1</sup> Not printed.

97. *Additional improvements considered but not recommended.*—A number of improvements desired by local interests, when investigated in detail, failed to show sufficient justification to warrant their inclusion in the general plan of improvement at this time. Description and details of the items not recommended are given in enclosures 8<sup>1</sup> and 11,<sup>1</sup> and the estimates of cost and results of economic analyses are included in enclosures 12<sup>1</sup> and 13,<sup>1</sup> respectively.

<sup>1</sup> Not printed.

## BENEFITS FROM IMPROVEMENTS

98. *General.*—Benefits expected to accrue from the improvements described in the general plan for flood control in the drainage basins of the Los Angeles and San Gabriel Rivers and Ballona Creek are divided into two broad classes—tangible benefits and intangible benefits. Tangible benefits are those to which a monetary value can be assigned. In this report they are separated into two parts: (a) Benefits from the prevention of flood damage in the probable route of floods during the life of the improvement, and (b) benefits from the removal of the flood menace in the alternate route of floods. Intangible benefits are the remaining benefits to which no monetary value is assigned. The estimated annual amounts of the monetary benefits which reasonably may be anticipated from flood control in the drainage basins discussed in this report are given in the following paragraphs. A more detailed analysis appears in enclosure 13.<sup>1</sup>

99. Flood-control benefits in the probable route of floods are confined to the prevention of flood damage, which comprises direct flood damage and indirect flood damage. Direct flood damage is physical damage measured by the cost of repair, replacement and cleaning. Indirect flood damage results from direct damage and is measured by certain nonrecoverable losses. These losses include loss of business income, loss of wages, losses from the interruption of utilities and transportation, the cost of temporary quarters, emergency expenditures for flood warning and relief, and the damage to the community as a whole as reflected by the depreciation in property values. The computation of the direct and indirect flood damage (par. 98 (a)), is also divided into two parts. The first part is the estimate of future direct and indirect flood damage on the basis of present values in the overflow area. The second part is the estimate of direct and indirect flood damage based on future growth in the overflow area, without flood control. The sum of these two estimates expressed as average annual amounts is the total benefit which may be expected to accrue in 50 years from the prevention of direct and indirect flood damage.

100. The removal of the flood menace in the alternative routes of floods (par. 98 (b)) provides an additional benefit which has been evaluated in this report and which is discussed later in more detail. The remaining benefits that accrue to a community as a whole, after the removal of the flood menace, are considered intangible. This type of benefit includes the prevention of loss of life and personal injury, removal of dangerous health conditions, and other general effects that lower the morale. Intangible benefits are not susceptible of monetary evaluation, and therefore do not appear in the final benefit-cost ratio. However, they represent increased social security, a benefit which should be given considerable weight in the areas considered in this report.

101. Water conservation, which is sometimes included as a benefit in flood-control reports in this area, is not included for reasons discussed in paragraphs 74-76. Although the detention of floodwaters by flood-control basins and debris basins would cause increased percolation to the underground water basins, this would be offset, in some degree, by the reduction in the present large overflow area and by the confinement of flood flows to the narrow improved channels. The

<sup>1</sup> Not printed.

actual increase or decrease in the amount of water conserved, due to flood-control improvements in this area, is difficult to determine.

102. A detailed analysis has been made of each of the improvements in the general plan and of each of the additional improvements considered in detail, but not recommended; the results of these analyses are given in enclosure 13.<sup>1</sup> A description of the method employed and summaries of the results obtained are given in the following paragraphs.

103. *Prevention of flood damage.*—From the history of past floods and a hydrologic analysis of the area, the number and magnitude of floods to be expected in a period of 50 years were estimated. The overflow areas were traced on a contour map and the types of physical flood damage were determined for the various units. From these fundamental data it was practicable to estimate the direct damage from a flood of each magnitude and the total damage from all floods within the economic life of the improvement. As has been stated, the direct damages were estimated in two parts; the first part was based on the damages that would occur to the existing development in the area. It is recognized that, in Los Angeles County, due to the comparatively long-time interval between major floods, there will be a continuing growth in the areas subject to overflow. Consequently, there will be a greater concentration of wealth in these areas when the anticipated floods occur. In the second part, an allowance for damage to this additional wealth was made by estimating the probable increase in wealth that would occur in each area. The amount of damage that would occur to existing and future additional improvements was estimated, using data from the 1938 flood-damage survey as a basis. The 1938 flood data were applied in a manner that allowed for the relative severity of the various floods considered. Reference is made to enclosure 13,<sup>1</sup> for a more detailed development of this analysis. Considering the existing and estimated future developments that would be protected if improvements were made in accordance with the general plan, the estimated direct flood damage that would be prevented in 50 years is estimated at \$586,200,000, which amounts to \$11,724,000 per annum.

104. The value of indirect damage was estimated from data obtained by a flood damage survey of the Los Angeles area following the 1938 flood, and from a review of the allowance for indirect damages used by other agencies for areas having similar development. Inasmuch as the indirect damages are applicable to the community as a whole, rather than to just the individual area damaged, it was not considered necessary to establish separate ratios of indirect damage to direct damage for various property classifications in the respective flood areas. Based on the above and in order to distribute to the individual projects their proportionate share of the indirect damages sustained by the entire community, an average value of 0.6 was used for all areas as the ratio of indirect to direct damages. The total of indirect damages that would occur during a 50-year period, as assigned to items recommended in the general plan, has been estimated at approximately \$351,700,000, or about \$7,034,000 per annum.

105. *Incidental benefits.*—In addition to damages to future additional improvements due to normal growth of the flooded area, it is recognized that flood control will permit a higher use of some of the

<sup>1</sup> Not printed.

lands. However, no separate estimate has been made of this incidental benefit for the areas on which direct and indirect flood damages have been estimated.

106. It was seen that, in a majority of the flood areas under consideration, it would be possible for the floods to take other paths than the one considered most probable. Direct and indirect damages, however, were estimated for only one path, but it was recognized that the removal of the flood menace to these alternate paths would be a benefit. It is believed that the removal of the flood menace from these alternate paths will be reflected in a permanent increase in their values, and therefore the annual benefits from this source were estimated at 5 percent of the estimated increase in value. The total benefits from the removal of the menace to these alternate paths by the construction of the items recommended in the general plan have been estimated as \$38,165,000, which at 5 percent per annum has an annual value of \$1,908,000.

107. *Summary of all benefits.*—The following table is a summary of all the aforesaid benefits expected to accrue from the improvements included in the general plan:

*Estimated annual monetary benefits from the general plan for flood control in the Los Angeles and San Gabriel Rivers and their tributaries, and Ballona Creek*

|                                                      |              |              |
|------------------------------------------------------|--------------|--------------|
| Prevention of flood damage (probable overflow area): |              |              |
| Direct flood damage prevented.....                   | \$11,724,000 |              |
| Indirect flood damage prevented.....                 | 7,034,000    |              |
|                                                      |              | \$18,758,000 |
| Incidental benefits (alternate overflow area): Re-   |              |              |
| moval of flood menace.....                           |              | 1,908,000    |
| Total.....                                           |              | 20,666,000   |

#### ECONOMIC COST OF IMPROVEMENTS

108. Separate economic analyses for the items in the general plan are given in enclosure 13.<sup>1</sup> Since the existing project and the recommended extensions thereof are designed to operate as a single unified plan, the combined economic costs are best presented as totals for the entire general plan, including both the existing project and its extensions. A summary of the economic costs is given in the following table:

*Economic cost of improvements in the Los Angeles and San Gabriel Rivers and their tributaries, and Ballona Creek*

##### a. Investment:

|                                                                                                                     |               |
|---------------------------------------------------------------------------------------------------------------------|---------------|
| (1) Estimated expenditure for new work of construction:                                                             |               |
| Channels, levees, debris basins, and flood-control basins.....                                                      | \$215,445,900 |
| Public utilities—relocation and reconstruction...                                                                   | 7,356,208     |
| Bridges—reconstruction.....                                                                                         | 23,159,377    |
| (2) Expenditure for lands, easements, and rights-of-way..                                                           | 22,203,201    |
| (3) Total, first cost.....                                                                                          | 268,164,686   |
| (4) Interest during construction, on item a (3) for one-half of the estimated construction period, at 3 percent.... | 18,348,821    |
| (5) Total, investment.....                                                                                          | 286,513,507   |

<sup>1</sup> Not printed.

38 LOS ANGELES AND SAN GABRIEL RIVERS AND BALLONA CREEK, CALIF.

*Economic cost of improvements in the Los Angeles and San Gabriel Rivers and their tributaries, and Ballona Creek—Continued*

|                                                                                                         |              |
|---------------------------------------------------------------------------------------------------------|--------------|
| b. Annual carrying charges:                                                                             |              |
| (1) Interest, 3½ percent on item a (5).....                                                             | \$10,028,151 |
| (2) Amortization of obsolescence and depreciation, in 50 years at 3½ percent (0.0076 × item a (5))..... | 2,177,825    |
| (3) Operation and maintenance of structures, items under a (1):                                         |              |
| Flood-control structures.....                                                                           | 1,331,475    |
| Public utilities.....                                                                                   | (2)          |
| Bridges.....                                                                                            | (2)          |
| (4) Total, annual carrying charges.....                                                                 | 13,537,451   |

<sup>1</sup> Operation and maintenance by present owners and will not exceed present expenditures.

RATIO OF BENEFITS TO COSTS

109. On the basis of the foregoing estimates of cost and the estimated average benefits, the ratio of total benefits to total costs for all the items listed in the general plan is 1.52. The following table gives the benefit-cost ratios of the individual items of the general plan.

*Ratios of benefits to economic costs for items of general plan Los Angeles and San Gabriel Rivers and their tributaries, and Ballona Creek*

|                                                                             | <i>Economic ratio</i> |
|-----------------------------------------------------------------------------|-----------------------|
| <b>Los Angeles River Basin:</b>                                             |                       |
| Los Angeles River, Sepulveda and Hansen flood-control basins.....           | 1.69                  |
| Pacoima wash and Lopez flood-control basin.....                             | 3.53                  |
| Caballero Creek.....                                                        | 1.18                  |
| Tujunga wash.....                                                           | 2.56                  |
| Wilson Diversion and Mansfield Channel.....                                 | 2.22                  |
| Lopez Canyon.....                                                           | 1.62                  |
| Haines Canyon.....                                                          | (1)                   |
| Blue Gum Canyon.....                                                        | 1.49                  |
| Burbank Western System.....                                                 | 1.20                  |
| Burbank Eastern System.....                                                 | 2.05                  |
| Blanchard Canyon.....                                                       | 1.47                  |
| Verdugo wash:                                                               |                       |
| Concord to Upper La Canada.....                                             | (1)                   |
| Upper La Canada to debris basin, inclusive.....                             | (2)                   |
| Dead Horse Canyon and Royal Blvd.....                                       | 2.25                  |
| Sycamore wash inlet.....                                                    | (1)                   |
| Winery Canyon.....                                                          | 1.17                  |
| Compton Creek:                                                              |                       |
| Los Angeles River to Hooper Ave. storm drain.....                           | (1)                   |
| Hooper Ave. storm drain to Main St.....                                     | 1.34                  |
| Combined items in Los Angeles River Basin.....                              | 1.77                  |
| <b>San Gabriel River Basin:</b>                                             |                       |
| San Gabriel River, Santa Fe, and Whittier Narrows flood-control basins..... | 1.10                  |
| Walnut Creek system.....                                                    | 1.06                  |
| Marshall Creek.....                                                         | 1.36                  |
| Emerald and Live Oak washes.....                                            | 1.30                  |
| Thompson Creek and San Jose wash.....                                       | 1.25                  |
| Coyote Creek.....                                                           | 1.06                  |
| Combined items in San Gabriel River Basin.....                              | 1.10                  |
| <b>Rio Hondo Basin:</b>                                                     |                       |
| Rio Hondo.....                                                              | 1.91                  |
| Sawpit wash.....                                                            | 1.97                  |

<sup>1</sup> Individual economic analyses have not been prepared for the items completed under the existing project; however, the cost of these items and a proportional share of their contributed benefits are included in the combined analyses of all general plan items for each basin and in the combined analysis of the general plan as a whole.

<sup>2</sup> Verdugo wash extension and debris basin enlargement are items necessary for the proper functioning of the completed Verdugo wash improvement, and although not susceptible of separate analysis, they have been included in the combined analyses.

<sup>3</sup> This section of main channel is an essential part of the improvements in the Rio Hondo and San Gabriel Basins and shows a favorable economic ratio when included with the improvements recommended for the Rio Hondo Basin.

*Ratios of benefits to economic costs for items of general plan Los Angeles and San Gabriel Rivers and their tributaries, and Ballona Creek—Continued*

|                                                                                                                                                             | <i>Economic ratio</i> |
|-------------------------------------------------------------------------------------------------------------------------------------------------------------|-----------------------|
| Rio Hondo Basin—Continued.                                                                                                                                  |                       |
| Santa Anita and Sierra Madre washes.....                                                                                                                    | 1. 40                 |
| Arcadia wash system.....                                                                                                                                    | 1. 38                 |
| Eaton wash.....                                                                                                                                             | 1. 76                 |
| Sierra Madre Villa Channel.....                                                                                                                             | 1. 40                 |
| Rubio diversion.....                                                                                                                                        | 4. 80                 |
| Alhambra wash.....                                                                                                                                          | (1)                   |
| Combined items in Rio Hondo Basin, including Rio Hondo Channel from Santa Fe flood-control basin (Flower Ave.) to Whittier Narrows flood-control basin..... | 1. 53                 |
| Ballona Creek Basin:                                                                                                                                        |                       |
| Ballona Creek Channel and jetties.....                                                                                                                      | (1)                   |
| Higgins and Coldwater Canyons.....                                                                                                                          | 1. 26                 |
| Benedict Canyon.....                                                                                                                                        | 2. 82                 |
| Sawtelle-Westwood system and Sepulveda Canyon.....                                                                                                          | 1. 10                 |
| Centinela Creek.....                                                                                                                                        | 1. 02                 |
| Combined items in Ballona Creek Basin.....                                                                                                                  | 1. 50                 |
| Combined items included in the general plan.....                                                                                                            | 1. 52                 |

<sup>1</sup> Individual economic analyses have not been prepared for the items completed under the existing project; however, the cost of these items and a proportional share of their contributed benefits are included in the combined analyses of all general plan items for each basin and in the combined analysis of the general plan as a whole.

110. The ratios of benefits to economic costs, for the items which were considered but which were excluded from the general plan because they were not found economically justified at this time, are given in the following tabulation:

*Ratios of benefits to economic costs—items excluded from the general plan on basis of economic analysis—Los Angeles and San Gabriel Rivers and their tributaries*

|                                                                                    | <i>Economic ratio</i> |
|------------------------------------------------------------------------------------|-----------------------|
| Los Angeles River Basin:                                                           |                       |
| Calabasas Creek, Dry Canyon, and Bell Creek.....                                   | 0. 26                 |
| Browns Creek and Santa Susana Creek.....                                           | . 56                  |
| Aliso Creek and Linekiln Creek.....                                                | . 55                  |
| Bull Creek.....                                                                    | . 88                  |
| Encino Creek.....                                                                  | . 81                  |
| May Canyon.....                                                                    | . 61                  |
| East Canyon.....                                                                   | . 65                  |
| Kagel Canyon.....                                                                  | . 15                  |
| Cooks Canyon.....                                                                  | . 43                  |
| Pickens Canyon.....                                                                | . 15                  |
| Gould and Paradise Canyons.....                                                    | . 46                  |
| Laguna Dominguez (Nigger Slough)—plan A.....                                       | . 16                  |
| San Gabriel River Basin: San Jose Creek, San Jose wash, and North Puente wash..... | . 26                  |
| Rio Hondo Basin: Bradbury and Spinks Canyons.....                                  | . 87                  |

LOCAL COOPERATION

111. With reference to act, Public, No. 738, Seventy-fourth Congress, approved June 22, 1936, authorizing expenditure of not to exceed \$70,000,000 for construction of flood-control improvements in Los Angeles County, Calif., the Board of Supervisors of Los Angeles County has, by appropriate resolution dated December 1, 1937, agreed to furnish all necessary rights-of-way, assume responsibility for all damage claims, and maintain the improvements after completion, all in accordance with the regulations prescribed by the Secretary of War and as required by section 3 of the above act. The Flood Control Act, approved June 28, 1938, and quoted in paragraph 38, modified the requirements as to local cooperation. Under this act, the United



States has assumed the obligations of the acquisition of rights-of-way and the cost of relocating public utilities and bridges, and is reimbursing local interests for expenditures made by them for those items of the existing project. Also the United States assumed responsibility for the maintenance and operation of the completed works of the existing project. The total saving to the local interests, due to the application of the act of June 28, 1938, to the existing project as originally authorized, will amount to approximately \$12,540,000, plus the saving in maintenance costs.

112. Although the act of June 28, 1938, rescinded such requirements of the act of June 22, 1936, that pertain to local interests' responsibility for (a) rights-of-way, (b) damages due to construction, and (c) responsibility for operation and maintenance, applicable to all projects adopted by Congress under the 1936 act and amendments thereto, and to all projects adopted under the 1938 act, there appears to be no authority under existing laws that requires the United States to assume such responsibilities and costs pertaining to new projects or in the extension of the existing project, except as may be included in subsequent acts. The district engineer believes that consideration of the preceding items, (a), (b), and (c), for any extension of the existing project should take into consideration the inherent local conditions applicable to each of the separate units that would constitute a part of the extension of the project, and bases his recommendation for required local cooperation upon a study of local conditions, the extent of national benefits as compared to local benefits, and the ability of the local community to pay a part of the costs. In order to give full consideration to the foregoing, the items of the district engineer's comprehensive plan for flood control (general plan) have been divided into three groups, A, B, and C. The items of group A are those comprising the existing project, and the items of groups B and C are those included in the recommended extension of the existing project. Group B includes the items required to complete the improvements on the main streams and parts of tributaries thereof that are necessary for the proper functioning of the general plan, as in the case of lower Burbank-Western and lower Sawtelle-Westwood, and to safeguard life and property where the flood menace is most serious. Group C includes other tributaries whereon the flood menace is not so serious and where the benefits of the improvements are considered to be largely local in character. The grouping of items in the general plan is shown in the following tables:

GENERAL PLAN--FLOOD CONTROL  
*Los Angeles and San Gabriel Rivers and their tributaries, and Ballona Creek, California*  
 [Cost summary--general plan, groups A, B, and C]

| Group                             | Cost to be borne by United States |              | Cost to be borne by local interests |              | Total cost    |              |
|-----------------------------------|-----------------------------------|--------------|-------------------------------------|--------------|---------------|--------------|
|                                   |                                   |              |                                     |              |               |              |
| Group A, existing project.....    |                                   | \$82,540,000 |                                     | 0            |               | \$82,540,000 |
| Group B, partial extension.....   | \$89,780,000                      |              | \$21,050,000                        |              | \$110,830,000 |              |
| Group C, remaining extension..... | 40,610,000                        |              | 34,180,000                          |              | 74,790,000    |              |
| Subtotals, group B+group C.....   |                                   | 130,390,000  |                                     | \$55,230,000 |               | 185,620,000  |
| Total.....                        |                                   | 212,930,000  |                                     | 55,230,000   |               | 268,160,000  |

GROUP A (EXISTING PROJECT)  
 [Entire cost to be borne by the United States]

| Item No. | Project item                                                     | Construction | Public utilities | Bridges   | Lands and rights-of-way | Total      | Percent complete Jan. 1, 1940 |
|----------|------------------------------------------------------------------|--------------|------------------|-----------|-------------------------|------------|-------------------------------|
| 1        | Haines Channel and debris basin.....                             | \$520,423    | \$3,110          | 0         | \$103,233               | \$626,766  | 100                           |
| 2        | Sycamore Wash Channel.....                                       | 23,546       | 0                | 0         | 4,439                   | 27,985     | 100                           |
| 3        | Verdugo Channel (Concord to Upper Canada Bridge).....            | 588,519      | 21,989           | \$260,367 | 216,438                 | 1,087,313  | 100                           |
| 4        | Alhambra.....                                                    | 1,017,586    | 34,902           | 61,905    | 91,220                  | 1,205,613  | 100                           |
| 5        | Compton Creek (Los Angeles River to Hooper Ave.).....            | 1,892,649    | 30,408           | 678,509   | 239,996                 | 2,841,562  | 100                           |
| 6        | Ballona Creek (channel and jetties).....                         | 1,052,215    | 91,165           | 412,141   | 394,579                 | 1,950,100  | 99                            |
| 7        | Hansen flood-control basin.....                                  | 8,500,000    | 480,000          | 0         | 1,400,000               | 10,380,000 | 82                            |
| 8        | Sepulveda flood-control basin.....                               | 4,000,000    | 1,364,000        | (1)       | 2,457,000               | 6,821,000  | 0                             |
| 9        | Los Angeles River Channel (Niagara to Stewart and Gray Rd.)..... | 41,355,612   | 1,199,334        | 1,786,855 | 725,796                 | 45,067,597 | 54                            |
| 10       | Excavation near Long Beach Blvd.....                             | 34,244       | 0                | 0         | 0                       | 34,244     | 100                           |
| 11       | Surveys and engineering.....                                     | 396,206      | 0                | 0         | 0                       | 396,206    |                               |
| 12       | San Gabriel Channel (Canon to Santa Fe).....                     | 1,720,000    | 12,000           | 204,000   | 150,000                 | 2,086,000  | 0                             |
| 13       | Santa Fe (flood-control basin).....                              | 8,899,000    | 50,000           | 0         | 1,068,000               | 10,017,000 | 0                             |
|          | Total.....                                                       | 70,000,000   | 2,286,908        | 3,403,777 | 6,850,701               | 82,541,386 |                               |

<sup>1</sup> Cost of two railroad bridges included in utilities.

GROUP B (RECOMMENDED EXTENSION TO EXISTING PROJECT)

[Required for adequate functioning of existing project (see Group C. Extension). Costs to be borne by United States: Construction, public utilities, railroad bridges. Local interests: Highways and highway bridges, lands and rights-of-way]

| Item No. | Project item                                                                           | Costs to United States |                  |                   |              | Costs to local interests     |                         |             | Total cost   |
|----------|----------------------------------------------------------------------------------------|------------------------|------------------|-------------------|--------------|------------------------------|-------------------------|-------------|--------------|
|          |                                                                                        | Construction           | Public utilities | Bridges, railroad | Total        | Highways and highway bridges | Lands and rights-of-way | Total       |              |
| 1        | Los Angeles River channel—Owensmouth to Niagara and Stewart and Gray Rd. to ocean..... | \$23,465,000           | \$2,660,000      | \$1,725,600       | \$27,850,600 | \$4,533,400                  | \$2,475,000             | \$7,008,400 | \$34,859,000 |
| 2        | Lopez flood-control basin.....                                                         | 4,683,000              | 0                | 0                 | 4,683,000    | 0                            | 96,000                  | 96,000      | 4,779,000    |
| 3        | Pacoima wash channel.....                                                              | 1,987,000              | 24,000           | 0                 | 2,011,000    | 534,000                      | 96,000                  | 630,000     | 2,641,000    |
| 4        | Tujunga wash channel.....                                                              | 6,931,000              | 90,000           | 259,200           | 7,280,200    | 333,800                      | 134,000                 | 467,800     | 7,748,000    |
| 5        | Verdugo wash (Upper Canada Bridge to debris basin).....                                | 1,078,000              | 0                | 0                 | 1,078,000    | 0                            | 14,000                  | 14,000      | 1,092,000    |
| 6        | San Gabriel River channel—Santa Fe flood-control basin to ocean.....                   | 13,029,000             | 498,000          | 506,000           | 14,033,000   | 1,013,000                    | 1,249,000               | 2,262,000   | 16,295,000   |
| 7        | Whittier Narrows flood-control basin.....                                              | 8,983,000              | 500,000          | 0                 | 9,483,000    | 0                            | 7,500,000               | 7,500,000   | 16,983,000   |
| 8        | Walnut Creek inlet channel.....                                                        | 2,095,000              | 18,000           | 90,000            | 2,203,000    | 175,000                      | 90,000                  | 265,000     | 2,468,000    |
| 9        | Rio Hondo channel.....                                                                 | 4,284,000              | 36,000           | 390,000           | 4,710,000    | 522,000                      | 117,000                 | 639,000     | 5,349,000    |
| 10       | Lopez diversion channel.....                                                           | 274,900                | 0                | 0                 | 274,900      | 0                            | 27,000                  | 27,000      | 301,900      |
| 11       | Wilson-Mansfield channel.....                                                          | 2,288,300              | 2,400            | 0                 | 2,290,700    | 0                            | 87,000                  | 87,000      | 2,377,700    |
| 12       | Eaton channel.....                                                                     | 2,612,000              | 29,000           | 109,000           | 2,750,000    | 428,000                      | 284,000                 | 712,000     | 3,462,000    |
| 13       | Rubio diversion channel.....                                                           | 927,000                | 0                | 0                 | 927,000      | 0                            | 19,000                  | 19,000      | 946,000      |
| 14       | Sawpit wash.....                                                                       | 1,637,200              | 9,000            | 100,800           | 1,747,000    | 241,200                      | 96,000                  | 337,200     | 2,084,200    |
| 15       | Santa Anita wash.....                                                                  | 3,345,000              | 24,000           | 204,000           | 3,573,000    | 294,000                      | 454,000                 | 748,000     | 4,321,000    |
| 16       | Sawtelle-Westwood (lower).....                                                         | 2,535,000              | 60,000           | 0                 | 2,595,000    | 18,000                       | 20,000                  | 38,000      | 2,633,000    |
| 17       | Burbank-Western (lower).....                                                           | 2,050,000              | 72,000           | 168,000           | 2,290,000    | 140,000                      | 63,000                  | 203,000     | 2,493,000    |
|          | Total.....                                                                             | 82,204,400             | 4,022,400        | 3,552,600         | 89,779,400   | 8,232,400                    | 12,821,000              | 21,053,400  | 110,832,800  |

1 Say, \$90,000,000.

2 Say, \$21,000,000.

42 LOS ANGELES AND SAN GABRIEL RIVERS AND BALLOXA CREEK, CALIF.

GROUP C (RECOMMENDED EXTENSION TO EXISTING PROJECT)

[Additional to group B: Items having substantial percentage of local benefits as compared to general flood-control benefits]

| Item No. | Project item                        | Costs to United States  |                  |                   |                   | Costs to local interests |                              |                         |                   | Total cost        |
|----------|-------------------------------------|-------------------------|------------------|-------------------|-------------------|--------------------------|------------------------------|-------------------------|-------------------|-------------------|
|          |                                     | 60 percent construction | Public utilities | Bridges, railroad | Total             | 40 percent construction  | Highways and highway bridges | Lands and rights-of-way | Total             |                   |
| 1        | Compton Creek.....                  | \$606,000               | \$34,500         | \$40,250          | \$680,750         | \$104,000                | \$332,250                    | \$50,000                | \$786,250         | \$1,467,000       |
| 2        | Arcadia system.....                 | 2,425,920               | 46,800           | 111,000           | 2,583,720         | 1,617,280                | 324,500                      | 192,000                 | 2,133,780         | 4,717,500         |
| 3        | Sierra Madre Villa.....             | 266,940                 | 0                | 0                 | 266,940           | 177,960                  | 0                            | 54,000                  | 231,960           | 498,900           |
| 4        | Marshall Creek.....                 | 528,900                 | 0                | 0                 | 528,900           | 352,600                  | 0                            | 34,000                  | 386,600           | 915,500           |
| 5        | Emerald-Liveoak.....                | 910,320                 | 15,600           | 100,200           | 1,026,120         | 606,880                  | 168,000                      | 70,000                  | 844,880           | 1,871,000         |
| 6        | Blue Gum.....                       | 60,330                  | 0                | 0                 | 60,330            | 40,220                   | 0                            | 6,000                   | 46,220            | 106,550           |
| 7        | Blanchard.....                      | 138,420                 | 0                | 0                 | 138,420           | 92,280                   | 0                            | 25,000                  | 117,280           | 255,700           |
| 8        | Winery.....                         | 273,180                 | 12,000           | 0                 | 285,180           | 182,120                  | 0                            | 30,000                  | 212,120           | 497,300           |
| 9        | Caballero.....                      | 792,570                 | 1,800            | 0                 | 794,370           | 528,380                  | 0                            | 50,000                  | 578,380           | 1,372,750         |
| 10       | Benedict.....                       | 2,491,500               | 299,000          | 0                 | 2,790,500         | 1,661,000                | 0                            | 228,500                 | 1,889,500         | 4,680,000         |
| 11       | Burbank-Eastern.....                | 4,397,400               | 90,000           | 140,000           | 4,627,400         | 2,931,600                | 0                            | 102,000                 | 3,033,600         | 7,661,000         |
| 12       | Dead Horse-Royal.....               | 230,760                 | 2,400            | 0                 | 233,160           | 153,840                  | 0                            | 17,000                  | 170,840           | 404,000           |
| 13       | Higgins-Coldwater.....              | 2,527,800               | 102,000          | 0                 | 2,629,800         | 1,635,200                | 0                            | 103,000                 | 1,738,200         | 4,418,000         |
| 14       | Sawtelle-Westwood (upper unit)..... | 3,166,200               | 72,000           | 0                 | 3,238,200         | 2,110,800                | 48,000                       | 195,000                 | 2,353,800         | 5,592,000         |
| 15       | Thompson Creek-San Jose Wash.....   | 1,934,760               | 19,200           | 148,800           | 2,102,760         | 1,289,840                | \$24,300                     | 81,000                  | 1,695,140         | 3,797,900         |
| 16       | Burbank-Western (upper unit).....   | 2,149,800               | 48,000           | 0                 | 2,197,800         | 1,433,200                | 46,000                       | 110,000                 | 1,589,200         | 3,787,000         |
| 17       | Walnut System.....                  | 10,730,100              | 225,000          | 396,400           | 11,341,500        | 7,153,400                | 2,716,000                    | 733,000                 | 10,602,400        | 21,943,900        |
| 18       | Centinela.....                      | 441,000                 | 6,600            | 0                 | 447,600           | 294,000                  | 190,800                      | 21,000                  | 505,800           | 953,500           |
| 19       | Coyote Creek.....                   | 3,873,000               | 72,000           | 690,000           | 4,635,000         | 2,582,000                | 2,204,000                    | 430,000                 | 5,216,000         | 9,851,000         |
|          | <b>Total.....</b>                   | <b>37,944,900</b>       | <b>1,046,900</b> | <b>1,616,650</b>  | <b>40,608,450</b> | <b>25,296,600</b>        | <b>6,353,950</b>             | <b>2,531,500</b>        | <b>34,182,050</b> | <b>74,790,500</b> |

<sup>1</sup> Say, \$41,000,000.

<sup>2</sup> Say, \$34,000,000.

113. The general plan and the grouping of the items thereof, as given in the table above, were discussed with local interests, principally with regard to local cooperation, and they agreed to provide police protection for all completed improvements in the general plan. In addition, they agreed to assume responsibility for all damage claims arising from flood-control works in extension of the existing project, except such as may be caused by faulty manual operation of the flood-control basins. The question of maintenance and operation was not discussed with local interests, since the act of 1938 has definitely assigned this function to the United States in case of the existing project, and it would be impracticable to have a division of such responsibility in the project as a whole. It is therefore believed that the United States should maintain and operate all flood-control structures of the general plan, in accordance with rules and regulations prescribed by the Secretary of War, under the direction of the Chief of Engineers, in order to assure the proper functioning of the entire project as a whole. This provision has been agreed to by local interests. With reference to acquisition of lands, easements, rights-of-way, and local contribution toward certain parts of the construction costs of the extension of the existing project, it is believed that the procedure should be as follows:

As a measure of local cooperation, local interests should (1) furnish to the United States, without reimbursement for the cost thereof, all lands, easements, flowage rights, and rights-of-way necessary for channel improvement or channel rectification and for debris and flood-control dams and basins; (2) bear the entire cost of relocation of highways and highway bridges; and (3) contribute 40 percent of the cost of the construction of the tributary channels listed in group C in table, paragraph 112.

114. It is believed that the local cooperation specified in the preceding paragraph is reasonable. Local government is organized to provide police protection for all improvements in the area, both public and private.

115. The measures of local cooperation pertaining to the furnishing of rights-of-way and contributions for relocation of bridges, and a proportionate share of the construction cost of certain channels in extension of the existing project, are considered justified, in view of the very large local benefits which will accrue, in addition to the general benefits.

116. The growth in population, business, and industrial production in the Los Angeles metropolitan area and of Los Angeles County has been abnormally large. The cities and towns have extended their boundaries rapidly and the expenditures for roads, streets, bridges, highways, water supplies, and other utilities have been very large. The tax rates in the various incorporated communities and within the different sections of Los Angeles City vary from about \$5.80 to \$3.90 per hundred dollars assessed valuation. The annual tax rate for flood control on land and improvements within Los Angeles County Flood Control District is 21.88 cents per hundred dollars of assessed valuation. Although major floods in the area are rather infrequent and of short duration, they are of great severity and, due to the steep slopes, high percentage of run-off, and scarcity of vegetation, they carry large quantities of debris and cause great damage, including loss of life. The periods of normal conditions with little or no rainfall

create a false sense of security. Funds for local flood control and storm-water drainage have therefore remained comparatively small, and it is only when severe floods occur with their devastating effects that public interest in the flood problem is aroused. It is therefore believed that local interests can afford to pay a fair proportion of the costs for such work, provided the cost is spread over a period of years. The present income of the Los Angeles County Flood Control District from taxes is about \$4,800,000 per annum, 61 percent of which, however, is required for amortization and interest on bonded indebtedness. This income will increase as the valuation of property in the county increases. For the next few years it will also be increased from reimbursements by the United States under the provisions of the act of June 28, 1938, for expenditures in connection with the existing project. These may total about \$3,600,000 by the end of the fiscal year 1943. The flood-control works that have been completed have already permitted the safe occupancy and development of areas formerly subject to destructive floods. Further development is certain. Such increases in land, residential, business, and industrial values provide large benefits to local interests as well as to the Nation as a whole.

117. All the items of the project do not have the same economic justification. Certain ones, although of small justification, are more necessary than some others for the proper functioning of the system as a whole. Others, although having small justification at the present time, have large potential justification in the benefits they will provide by preventing damage to future developments. An analysis of each of the items of the general plan leads to the belief that the local flood-control district should bear a portion of the construction cost of certain items, as well as the costs of rights-of-way and relocation of highways and highway bridges.

118. In view of the foregoing, it is believed that the required local cooperation should be as follows:

(a) Provide police protection for all completed flood-control works of the existing project and the extension thereof.

(b) Hold and save the United States free from all claims for damages due to the construction and operation of the extension of the project, except damage claims caused by faulty manual operation of flood-control basins.

(c) Provide, without cost to the United States, all lands, easements, and rights-of-way necessary for the construction of the extension of the project and assume the cost of the relocation of highways and highway bridges required in the extension of the project.

(d) Contribute in advance, for any item in group C of the table, paragraph 112, as required by the Chief of Engineers, United States Army, 40 percent of the construction cost of that item.

119. As indicated by appropriate resolution, appended hereto, passed by the Los Angeles County Board of Supervisors, February 6, 1940, the board is willing to undertake to the best of its ability, if required by Congress, the obligations of:

(a) Acquiring all lands, easements, or other forms of rights-of-way necessary to the construction of flood control and appurtenant improvements in the extension of the existing project.

(b) Relieving the United States Government of all liability for claims for damages arising from the construction of said extension of the existing project,

except for damages such as might be caused by faulty manual operation of flood-control basins and similar structures.

(c) Providing police protection for all completed flood-control works of the extension of the project and the existing project.

(d) Contributing to the cost of construction of certain of the flood-control and appurtenant improvements, which have a substantial percentage of local benefits, as compared to general flood-control benefits.

The cooperation offered at this time is predicated upon the ability of the Los Angeles County Flood Control District to finance its required cooperation. It is believed that if the general plan for flood control is adopted, local cooperation herein recommended will be met without undue financial burden on the communities to be benefited.

#### SUMMARY AND DISCUSSION

120. The area considered in this report consists of the adjacent drainage basins of Los Angeles River, San Gabriel River, their inter-connecting stream, the Rio Hondo, and Ballona Creek, and lies principally in Los Angeles County, Calif. The area, amounting to 1,717 square miles, is composed of mountains, hills, valleys, and a coastal plain. The main streams are relatively short and the slopes in the mountainous section are steep; and, with the short-time rainfall intensities characteristic of southern California, quick run-off and sharp flood peaks result. The action of the high velocity of flood-water on land that is easily eroded causes large quantities of debris to move downstream. The coarser particles are deposited at the mouths of the canyons in fan-shaped cones, and the lighter particles are transported farther and dropped as the carrying power of the water decreases. The resultant accretion diminishes the capacity of the channels, causing the streams to take a new course. In the past, the combination of severe floods with debris flow and unstable channels has caused loss of life and excessive property damage, and is likely to cause still greater damage in the future, unless adequate protection is provided.

121. The total 1939 population in the area considered is estimated at 2,400,000; and it is estimated that 800,000 live in the area subject to overflow. The total true value of property in Los Angeles County was about \$5,600,000,000 in 1938, and most of it is concentrated in or near this area. Within the area subject to overflow, the true value of property is estimated at more than \$1,000,000,000. To protect this thickly populated and highly developed locality from storm waters and floods, the city and county of Los Angeles have expended about \$109,000,000; and many smaller municipalities within the county, as well as various private interests therein, have spent considerable amounts of money. Two Federal agencies, the Work Projects Administration and the War Department, have expended approximately \$90,000,000 of a total of about \$135,000,000 authorized for expenditure by these agencies, the greater part of such expenditure being for flood control.

122. Although some of the funds included in the preceding amounts were used for local drainage or for water conservation, the greater part was used in an effort to reduce the general flood menace in the entire community. The existing improvements are of great value in reducing flood damage within their respective areas of influence, and the remaining works to be constructed with the balance of the funds

authorized by the Flood Control Act of June 22, 1936, will provide protection for additional areas. Nevertheless, large areas will still remain unprotected from floods, and it is the primary purpose of this report to determine the degree of justification for additional flood-control improvements needed and to set up a general plan of improvement to insure proper functioning of all parts of such general plan.

123. Local interests desire an adequate and unified comprehensive flood-control plan to protect all areas now unprotected. Since the character and value of property in the various parts of the overflow area vary widely, it was found upon preliminary examination that the cost of providing adequate protection for certain parts was in excess of the respective benefits to each area. The plans of improvement presented by local interests were, therefore, analyzed so as to segregate those units which are justified at this time and to include them as parts of a general or comprehensive plan.

124. This study has shown that certain improvements can be combined in such a general plan. The improvements requested by local interests which are not included in the general plan have been given sufficient consideration to show that the cost of protective works exceeds the anticipated benefits. Briefly stated, the general plan includes the construction of three flood-control basins on Los Angeles River and its tributaries, two flood-control basins on the San Gabriel River, numerous debris basins at the canyon mouths of the various tributaries, and extensive channel work on the main streams and certain tributaries of Los Angeles and San Gabriel Rivers, Rio Hondo, and Ballona Creek. The estimated total cost of the extension of the existing project is \$186,000,000, of which \$146,000,000 is for construction, \$5,000,000 for relocation of utilities, \$5,200,000 for railroad bridges, \$15,300,000 for rights-of-way, and \$14,600,000 for relocation of highways and highway bridges. The recommended local cooperation would require that local interests furnish rights-of-way, pay for relocation of highways and highway bridges, and contribute toward the construction cost of certain items, the total contribution being equivalent to about \$55,000,000.

125. The annual carrying charges on the estimated cost of the general plan are estimated at about \$13,540,000. The annual benefits from the prevention of flood damage and its attendant losses, including the provision of opportunity for higher development in the overflow area, amount to approximately \$20,700,000. The ratio of annual benefits that are susceptible of monetary evaluation to annual charges is about 1.52.

126. In this highly developed metropolitan area the intangible benefits to the community as a whole are considerable. The New Year's flood of 1934, although confined to a small area, caused a loss of more than 40 lives, and during the 1938 flood the loss of life was larger. In addition to loss of life, personal injury and sickness follow major floods, the morale of the people suffers severely, and innumerable hardships are inflicted on those unable financially to meet such a catastrophe. Lifetime savings of numerous persons with moderate or low incomes are invested in homes in the overflow area, and it is believed that such financial security as this property affords will be irretrievably lost if the menaced areas remain unprotected from future floods. For these reasons it is believed that the intangible benefits from the additional proposed improvements would be very high, and in combination with



the tangible benefits, indicated by the monetary ratios, would amply justify the construction of the various parts of the recommended general plan.

CONCLUSIONS

127. It is concluded that destructive floods in the basins of Los Angeles and San Gabriel Rivers, Rio Hondo, and Ballona Creek will be only partly controlled after the completion of the existing project; that the existing project and the extension of its improvements, referred to in this report as the general plan, will provide benefits, both local and general, in excess of the estimated cost thereof; that the construction by the United States of the improvements included in the general plan is warranted, subject to conditions of local cooperation discussed in paragraphs 111-119; and that an equitable distribution of the cost of such a modified project would be as follows:

|                                                                                                       |                |
|-------------------------------------------------------------------------------------------------------|----------------|
| Authorized for construction cost under existing project.....                                          | \$70, 000, 000 |
| Estimated cost of lands, easements, and rights-of-way for work authorized under existing project..... | 12, 540, 000   |
| Cost to the United States of the recommended extension of existing project.....                       | 131, 000, 000  |
| Cost to local interests of the extension of the existing project as recommended.....                  | 55, 000, 000   |
| Estimated total cost of general plan, say.....                                                        | 268, 000, 000  |

RECOMMENDATIONS

128. The district engineer recommends:

(a) That the existing project, which provides for the construction of reservoirs and principal flood channels in the Los Angeles and San Gabriel Rivers and their tributaries, and Ballona Creek, Calif., at an estimated construction cost not to exceed \$70,000,000, and at an estimated cost for lands and damages of \$12,540,000, be modified by the inclusion of additional improvements in extension thereof, at an estimated cost of \$186,000,000, and at an operation and maintenance cost estimated at \$1,330,000 per annum.

(b) That local interests be required to cooperate as follows: (1) Provide police protection for all completed flood-control works of the existing project and extension thereof; (2) hold and save the United States free from all claims for damages due to the construction and operation of the extension of the project, except damage claims caused by faulty manual operation of flood-control basins; (3) furnish free of cost to the United States, all lands, easements, flowage rights, and rights-of-way necessary for channel improvement or channel rectification and for debris and flood-control dams and basins required for extension of the existing project; (4) assume the cost of the relocation of highways and highway bridges required in extension of the existing project; and (5) contribute 40 percent of the cost of the construction of the tributary channels listed in group C of table, paragraph 112.

(c) That the United States pay all other costs and perform all other work entailed in connection with the construction, maintenance, and operation of the existing project and extension thereof.

(d) That all items in the extension of the existing project be executed according to plans to be approved by the Chief of Engineers, United States Army, and in the order directed by him.

(e) That the United States operate and maintain all flood-control works of the existing project and extension thereof, under the direction of the Secretary of War and supervision of the Chief of Engineers.

(f) That those items, upon which local contributions of 40 percent of construction costs are required, be constructed at such time as the Los Angeles County Flood Control District is able to finance and meet the required local cooperation.

(g) That Federal funds be made available in allotments of not less than \$20,000,000 per annum.

EDWIN C. KELTON,  
*Lieutenant Colonel, Corps of Engineers,*  
*District Engineer.*

[First endorsement]

OFFICE, DIVISION ENGINEER,  
SOUTH PACIFIC DIVISION,  
*San Francisco, Calif., February 12, 1940.*

To the CHIEF OF ENGINEERS, UNITED STATES ARMY:

1. *Descriptive.*—The Los Angeles and San Gabriel Rivers, emptying into the ocean at San Pedro Bay, constitute the principal drainage systems of Los Angeles County. Rio Hondo, the largest natural tributary of Los Angeles River, drains a portion of the natural drainage basin of San Gabriel River; and Ballona Creek discharges into the ocean at Santa Monica Bay, the run-off from the southern slope of the easterly portion of the Santa Monica range of mountains. These systems together drain a total of 1,717 square miles, which includes all the industrial, commercial, and residential communities of the Los Angeles County area.

2. The improved area is open to the sea on the southeast, low-lying and generally level for a considerable distance inland from the coast, and then rising gently to the base of a system of hills and mountains enclosing the area in the inland sector. The mountains vary in general altitude from about 3,000 feet in the northwest to between 5,000 and 7,000 feet in the remaining portions, with individual peaks rising to heights up to 10,000 feet. The hills and mountains are generally rugged, with numerous canyons opening directly onto the improved area.

3. The 44 incorporated cities within the area contain about 88 percent of the total population, which was estimated to be 2,450,000 in 1938. The largest city is Los Angeles, with a population of 1,360,000 and bank debits (in 1938) of \$9,787,000,000. Industrial activities, principally petroleum production and refining, motion-picture production, airplane production, automobile assembling, and miscellaneous manufacture, yielded a gross return of \$1,350,000,000 in 1937. The value of agricultural products was \$76,000,000 in 1938. Commerce passing through Los Angeles-Long Beach Harbors for the year ending June 30, 1938, amounted to more than 22,000,000 tons valued at over a billion dollars.

4. *Flood conditions.*—The average annual precipitation varies from about 10 inches near the coast to about 40 inches in the high mountains. Approximately 80 percent of the annual rainfall occurs during the

4-month period from December to March. The maximum recorded daily rainfall for Los Angeles is 5.88 inches, and for the mountain areas is 17.55 inches. Intense winter storms convert the usually dry stream beds into raging torrents, which flow with very high velocities on the steep slopes of the upper channels, eroding bordering areas and flooding wide areas of improved property. Where canyons open onto the sloping foothill area, the floodwaters deposit great quantities of rock, boulders, gravel, and sand upon the adjacent area. This debris deposit often results in complete destruction of the property values, in some cases covering property to a depth greater than the height of homes and other buildings on the land.

5. The rapid expansion within the basin of residential areas during recent past years, together with an ignorance or disregard of the local flood conditions, has resulted in building and making other improvements in areas known to be subject to damage by greater than usual floods. This condition is responsible to some extent for the large amount of damages done by the unusual floods. The overflow area includes 800,000 residents and property valued at over \$1,000,000,000. The flood of 1934 resulted in damage estimated by the Los Angeles County Flood Control District as \$6,082,300 and caused the loss of 41 lives; the flood of 1938 resulted in damage estimated by the United States engineer office, Los Angeles, as \$40,409,127 and caused the loss of 49 lives.

6. *Existing improvements.*—Various agencies of local government have expended large sums for the construction and maintenance of storm drains and works for flood control and water conservation. The Los Angeles County Flood Control District has been the agency responsible for construction of most of the locally financed flood-control improvements, which consist chiefly of 12 flood-storage reservoirs on the upper tributary streams, several debris-retention basins, 1 diversion dam, and many miles of channel improvement. The local expenditures cannot be readily segregated as to purpose, but the total expenditures of local funds for all such purposes is about \$112,000,000.

7. Under the conditions of the Emergency Relief Appropriation Act of 1935 the War Department supervised the construction of certain flood-control work consisting of six debris-retention basins, one flood and debris storage basin, and channel improvement work on Los Angeles River and tributaries and on Ballona Creek. Federal funds expended for this work, together, with Federal funds appropriated by Federal relief agencies, such as Works Progress Administration and Civil Works Administration, as direct Federal assistance in constructing the works accomplished by local agencies has totaled about \$54,000,000.

8. Upon completion, the existing project for Los Angeles County drainage area, California—flood control will have provided jetties and channel improvement on Ballona Creek, channel improvement on the central section of Los Angeles River with channel improvement and debris retention basins on some of its tributaries, channel improvement of an upper section of San Gabriel River, and three large flood storage reservoirs—two in the foothill area of Los Angeles River and one in the foothill area of San Gabriel River. The items of the existing project are a part of those comprising a comprehensive plan for flood protection of the entire Los Angeles County area, and are the items which generally would be accomplished first, either because of the

condition of the present channels or because of their relation to the comprehensive plan. It is estimated that the total cost of the existing project will be about \$82,540,000, the legal limit of expenditures for construction being \$70,000,000.

9. The total cost of the works outlined in the preceding paragraphs, upon completion of the existing project, will be about as estimated below:

|                                                                                       |                    |
|---------------------------------------------------------------------------------------|--------------------|
| Funds by local agencies, for water conservation, storm drains, and flood control..... | \$112,000,000      |
| Funds by Federal relief agencies, for storm drains and flood control.....             | 54,000,000         |
| Funds by the War Department, for flood control under the existing project.....        | 82,540,000         |
| <b>Total.....</b>                                                                     | <b>248,540,000</b> |

10. *Additional improvements.*—At a public hearing conducted by the district engineer, local interests, represented chiefly by the Los Angeles County Flood Control District, requested adequate protection against floods in the Los Angeles County area by means of flood storage basins, debris retention basins, and channel improvements, in general accordance with a comprehensive plan developed by the flood control district, and requested that water conservation be coordinated with flood control to the extent practicable. The district engineer has considered the requests of local interests and has prepared a list of such items included in the comprehensive plan which he believes can be justified at this time. He proposes a plan, in extension of the existing project, which calls for general improvement of Ballona Creek and Los Angeles and San Gabriel Rivers, and many of the tributaries thereto, by means of channel improvement, debris retention basins, and flood storage basins, all as shown on page 1 of enclosure 1 to his report. He estimates the total cost of such items in extension of the existing project which he finds justified at this time at \$185,623,300. The existing project and its extension would cost an estimated total of \$268,164,686, which represents an annual carrying charge, including operation and maintenance costs of \$1,331,000, amounting to \$13,537,000.

11. In justification of this estimated cost, the district engineer estimates that the resultant average annual benefits will amount to \$20,666,000, giving a ratio of benefits to cost of 1.52. He estimates the costs and benefits for the individual items which can be justified to be as given in the following tabulation:

| Item                                                                             | Cost         | Annual cost | Average annual benefit         |                              |                    |             | Ratio |
|----------------------------------------------------------------------------------|--------------|-------------|--------------------------------|------------------------------|--------------------|-------------|-------|
|                                                                                  |              |             | Damage to existing development | Damage to future improvement | Incidental benefit | Total       |       |
| Los Angeles River:<br>Channel and Hansen and Sepulveda flood-control basins..... | \$97,558,047 | \$5,205,091 | \$6,650,300                    | \$1,800,800                  | \$375,000          | \$8,826,100 | 1.69  |
| Lopez flood-control basin and Pacoima wash.....                                  | 7,420,000    | 349,600     | 518,400                        | 400,000                      | 316,000            | 1,234,400   | 3.53  |
| Caballero Creek.....                                                             | 1,372,750    | 76,770      | 51,800                         | 22,800                       | 15,900             | 90,400      | 1.18  |
| Tujunga wash.....                                                                | 7,748,000    | 371,300     | 387,100                        | 298,000                      | 265,000            | 950,600     | 2.56  |
| Wilson Canyon and Mansfield St. Channel.....                                     | 2,377,700    | 122,300     | 159,000                        | 52,500                       | 60,200             | 271,700     | 2.22  |
| Lopez Canyon.....                                                                | 301,900      | 20,500      | 18,100                         | 6,000                        | 9,000              | 33,100      | 1.62  |
| Haines Canyon.....                                                               | 626,766      | (1)         | (1)                            | (1)                          | (1)                | (1)         | (1)   |

See footnotes at end of table.

52 LOS ANGELES AND SAN GABRIEL RIVERS AND BALLONA CREEK, CALIF.

| Item                                                                              | Cost        | Annual cost | Average annual benefit         |                              |                    |            | Ratio |
|-----------------------------------------------------------------------------------|-------------|-------------|--------------------------------|------------------------------|--------------------|------------|-------|
|                                                                                   |             |             | Damage to existing development | Damage to future improvement | Incidental benefit | Total      |       |
| <b>Los Angeles River—Con.</b>                                                     |             |             |                                |                              |                    |            |       |
| Blue Oum Canyon.....                                                              | \$106,550   | \$7,200     | \$9,500                        | \$1,000                      | \$200              | \$10,700   | 1.49  |
| Burbank Western System.....                                                       | 6,280,000   | 355,900     | 236,000                        | 156,000                      | 30,900             | 428,900    | 1.20  |
| Burbank Eastern System.....                                                       | 7,611,000   | 352,900     | 446,000                        | 196,000                      | 81,400             | 723,400    | 2.05  |
| Blanchard Canyon.....                                                             | 255,700     | 17,400      | 20,200                         | 4,500                        | 1,000              | 25,700     | 1.47  |
| Verdugo wash.....                                                                 | 2,179,313   | (?)         | (?)                            | (?)                          | (?)                | (?)        | (?)   |
| Royal Blvd. and Dead Horse Canyon.....                                            | 404,000     | 22,700      | 51,000                         | 0                            | 0                  | 51,000     | 2.25  |
| Sycamore wash Inlet <sup>1</sup> .....                                            | 27,985      | (?)         | (?)                            | (?)                          | (?)                | (?)        | (?)   |
| Winery Canyon.....                                                                | 497,300     | 29,000      | 25,000                         | 5,500                        | 3,400              | 33,900     | 1.17  |
| Compton Creek to Hooper Ave. <sup>2</sup> .....                                   | 2,841,562   | (?)         | (?)                            | (?)                          | (?)                | (?)        | (?)   |
| Compton Creek, Hooper to Main St.....                                             | 1,467,000   | 67,300      | 28,400                         | 61,400                       | 0                  | 89,800     | 1.34  |
| Basin total.....                                                                  | 139,125,573 | 7,265,243   | 8,632,800                      | 3,080,000                    | 1,168,200          | 12,881,000 | 1.77  |
| <b>San Gabriel River:</b>                                                         |             |             |                                |                              |                    |            |       |
| Channel and Santa Fe and Whittier Narrows flood-control basins <sup>1</sup> ..... | 45,381,000  | 2,153,000   | 1,130,300                      | 1,218,000                    | 0                  | 2,378,300  | 1.10  |
| Walnut Creek system.....                                                          | 24,411,900  | 1,183,900   | 710,100                        | 395,600                      | 133,700            | 1,250,400  | 1.06  |
| Marshall Creek.....                                                               | 915,500     | 56,800      | 43,400                         | 23,800                       | 9,000              | 77,100     | 1.36  |
| Emerald and Live Oak washes.....                                                  | 1,871,000   | 105,500     | 72,800                         | 40,000                       | 24,800             | 137,600    | 1.30  |
| Thompson Creek and San Jose wash.....                                             | 3,797,900   | 193,100     | 65,500                         | 30,600                       | 140,100            | 211,600    | 1.25  |
| Coyote Creek.....                                                                 | 9,851,000   | 465,500     | 235,600                        | 258,000                      | 0                  | 493,600    | 1.06  |
| Basin total.....                                                                  | 86,228,300  | 4,157,800   | 2,266,700                      | 2,001,400                    | 310,500            | 4,578,600  | 1.10  |
| <b>Rio Hondo:</b>                                                                 |             |             |                                |                              |                    |            |       |
| Channel, Santa Fe to Whittier flood-control basins.....                           | 5,349,000   | 273,600     | 107,000                        | 118,000                      | 22,700             | 247,700    | .81   |
| Sawditt wash.....                                                                 | 2,084,200   | 120,600     | 46,400                         | 30,600                       | 160,000            | 237,000    | 1.97  |
| Santa Anita and Sierra Madre washes.....                                          | 4,321,000   | 210,600     | 154,700                        | 85,200                       | 54,800             | 294,700    | 1.40  |
| Arcadia wash system.....                                                          | 4,717,500   | 240,400     | 170,800                        | 113,000                      | 40,400             | 330,200    | 1.38  |
| Eaton wash.....                                                                   | 3,462,000   | 168,600     | 152,300                        | 100,500                      | 42,500             | 295,300    | 1.76  |
| Sierra Madre Villa Channel.....                                                   | 498,900     | 35,700      | 22,000                         | 14,500                       | 13,500             | 50,000     | 1.40  |
| Huilo diversion.....                                                              | 940,000     | 85,700      | 182,000                        | (?)                          | 89,600             | 271,600    | 4.80  |
| Alhambra wash <sup>1</sup> .....                                                  | 1,205,613   | (?)         | (?)                            | (?)                          | (?)                | (?)        | (?)   |
| Basin total.....                                                                  | 22,584,213  | 1,161,643   | 975,600                        | 474,900                      | 429,500            | 1,780,200  | 1.53  |
| <b>Ballona Creek:</b>                                                             |             |             |                                |                              |                    |            |       |
| Channel and jetties <sup>1</sup> .....                                            | 1,950,100   | (?)         | (?)                            | (?)                          | (?)                | (?)        | (?)   |
| Higgins and Coldwater Canyons.....                                                | 4,418,000   | 202,100     | 229,600                        | 25,300                       | 0                  | 254,900    | 1.26  |
| Benedict Canyon.....                                                              | 4,680,000   | 222,400     | 563,600                        | 62,000                       | 0                  | 625,600    | 2.82  |
| Sepulveda Canyon and Sawtelle-Westwood system.....                                | 8,225,000   | 389,500     | 383,100                        | 43,400                       | 0                  | 426,500    | 1.10  |
| Centinela Creek.....                                                              | 953,500     | 46,000      | 16,500                         | 31,600                       | 0                  | 48,100     | 1.02  |
| Basin total.....                                                                  | 20,226,600  | 952,765     | 1,207,100                      | 218,800                      | 0                  | 1,425,900  | 1.50  |
| Total plan.....                                                                   | 268,161,890 | 13,537,451  | 12,982,400                     | 5,775,100                    | 1,908,200          | 20,665,700 | 1.52  |

<sup>1</sup> Item already included, as a whole or in part, in the existing project.  
<sup>2</sup> Completed item of the existing project. Individual economic analysis was not made, but costs and benefits are included in basin totals.  
<sup>3</sup> This total cost is made up of the following items:

| Item                            | Existing project | Project extension | Total plan    |
|---------------------------------|------------------|-------------------|---------------|
| Flood-control construction..... | \$70,000,000     | \$145,445,900     | \$215,445,900 |
| Relocation of utilities.....    | 2,285,908        | 5,019,300         | 7,305,208     |
| Reconstruction of bridges.....  | 3,403,777        | 19,755,600        | 23,159,377    |
| Lands and rights-of-way.....    | 6,850,701        | 15,352,600        | 22,203,301    |
| Total cost.....                 | 82,541,386       | 185,623,300       | 268,164,686   |

12. *Conclusions and recommendations of the district engineer.*—The district engineer finds that some extension of the existing project is justified and necessary for the proper functioning of the general plan for flood control, and that additional extension is justified by the tangible and intangible benefits which would accrue therefrom. His recommendations are essentially as follows:

(a) That the existing project be modified, by the inclusion of additional items in extension thereof, to complete the general plan for flood control as outlined in tabular form in paragraph 11 above, at an additional cost to the United States of \$130,390,000 and an increase in the cost for maintenance and operation of the completed works to an estimated total of \$1,330,000 per year.

(b) That local interests be required to (1) provide police protection for all completed flood-control works of the existing project and extension thereof; (2) hold and save the United States free from all claims for damages due to the construction and operation of the extension of the project, except damage claims based upon faulty manual operation of flood-control basins; (3) furnish, free of cost to the United States, all lands, easements, flowage rights, and rights-of-way necessary for channel improvement or channel rectification and for debris and flood-control dams and basins required for extension of the existing project; (4) assume the cost of the relocation of highways and highway bridges necessitated by extension of the existing project; and (5) contribute 40 percent of the cost of the construction of flood-control improvements on tributary channels, improvement of which is not essential to a proper functioning of the general flood-control plan, and which he considers in paragraph 112 of his report as "group C" improvements; all at an additional cost to local interests of about \$55,230,000.

(c) That the United States pay all other costs and perform all other work entailed in connection with the construction, maintenance, and operation of the existing project and extension thereof.

(d) That all items in the extension of the existing project be executed according to plans to be approved by the Chief of Engineers, United States Army, and in the order directed by him.

(e) That the United States operate and maintain all flood-control works of the existing project and extension thereof, under the direction of the Secretary of War and supervision of the Chief of Engineers.

(f) That construction of those items upon which local contributions of 40 percent of construction costs are required shall be deferred until such time as the conditions of local cooperation have been complied with.

(g) That Federal funds for construction of the extension recommended be made available in allotments of not less than \$20,000,000.

13. *Recommendation of the division engineer.*—The division engineer concurs in the conclusions and recommendations of the district engineer.

WARREN T. HANNUM,  
Colonel, Corps of Engineers,  
Division Engineer.

ENCLOSURES ACCOMPANYING THIS REPORT

(Only p. 1 of enclosure 1 printed)

Enclosure:

1. General maps:
  - Page 1. General plan.
  - Page 2. Distribution of population and areas subject to overflow.
  - Page 3. Principal highways and railroad lines.
  - Page 4. Los Angeles and San Gabriel Rivers, Rio Hondo, and Ballona Creek, location and condition of existing bridges after flood of March 2, 1938.
2. Statistics, Los Angeles County.
3. Tabulation of prior reports.
4. List of bridges.
5. History of past floods.
6. Hydrology in the Los Angeles County drainage area:
  - I. General.
  - II. Los Angeles River drainage system.
  - III. San Gabriel-Rio Hondo drainage system.
  - IV. Ballona Creek and Laguna Dominguez (Nigger Slough)
  - V. Climatology and meteorology.
  - VI. Basic data for analysis of hydrology.
  - VII. Factors influencing method of computing design flood.
  - VIII. Computation of design flood by "rational method."
  - IX. Discussion of design and observed data.
  - X. Summary of hydrology.
7. Description of the general plan.
8. Description of additional improvements considered but not recommended at this time.
9. General plan, Los Angeles River Basin:
  - Page 1. Index map, Los Angeles River Basin.
  - Pages 2 to 20. Los Angeles River, Owensmouth Avenue to Pacific Ocean.
  - Pages 21 to 23. Hansen flood-control basin.
  - Pages 24 to 28. Sepulveda flood-control basin.
  - Pages 29 to 30. Pacoima wash, Lopez flood-control basin.
  - Page 31. Caballero Creek.
  - Pages 32 to 34. Tujunga wash.
  - Pages 35 to 36. Pacoima wash.
  - Page 37. Wilson Canyon.
  - Pages 38 to 39. Mansfield Street Channel.
  - Page 40. Lopez Canyon.
  - Page 41. Index map, Burbank Western and Eastern Systems.
  - Pages 42 to 46. Burbank Western System.
  - Pages 47 to 48. Burbank Eastern System.
  - Page 49. Blue Gum Canyon.
  - Page 50. Blanchard Channel.
  - Pages 51 to 54. Verdugo wash.
  - Page 55. Royal Boulevard Channel.
  - Page 56. Dead Horse Canyon.
  - Page 57. Winery Canyon.
  - Pages 58 to 62. Compton Creek.
10. General plan, San Gabriel River, Rio Hondo, and Ballona Creek Basins:
  - Page 1. Index map.

SAN GABRIEL RIVER BASIN

- Pages 2 to 13. San Gabriel River, San Gabriel Canyon to Pacific Ocean.
- Page 14. Anaheim Bay Bypass.
- Page 15. Alamitos Bay separation.
- Pages 16 to 19. Santa Fe flood-control basin.
- Pages 20 to 25. Whittier Narrows flood-control basin.
- Pages 26 to 28. Little Dalton wash.
- Pages 29 to 33. Big Dalton wash.
- Pages 34 to 36. San Dimas wash.
- Pages 37 to 40. Walnut Creek wash.
- Page 41. Marshall Creek.
- Pages 42 to 43. Emerald wash.

Page 44. Live Oak wash.  
Pages 45 to 47. Thompson Creek.  
Pages 48 to 50. San Jose wash.  
Pages 51 to 55. Coyote Creek.  
Pages 56 to 57. North Fork, Coyote Creek.

RIO HONDO BASIN

Pages 58 to 62. Rio Hondo.  
Pages 63 to 64. Sawpit wash.  
Pages 65 to 67. Santa Anita wash.  
Page 68. Sierra Madre wash.  
Pages 69 to 73. Arcadia wash.  
Pages 74 to 79. Eaton wash.  
Page 80. Sierra Madre Villa Channel.  
Page 81. Rubio diversion.

BALLONA CREEK BASIN

Page 82. Higgins and Coldwater Canyons.  
Page 83. Benedict Canyon.  
Page 84. Sepulveda Canyon.  
Page 85. Sawtelle-Westwood system.  
Page 86. Centinela Creek.  
11. Additional improvements considered but not recommended:  
Page 1. Index map.

LOS ANGELES RIVER BASIN

Pages 2 to 3. Bell Creek.  
Page 4. Bell Creek, North Fork and Chatsworth Branch.  
Pages 5 to 6. Calabasas Creek.  
Page 7. Dry Canyon wash.  
Pages 8 to 10. Browns Creek.  
Page 11. Santa Susana Creek.  
Pages 12 to 14. Aliso Creek.  
Page 15. Aliso Creek, West Branch and West Fork.  
Pages 16 to 17. Limekiln Creek.  
Pages 18 to 20. Bull Creek.  
Page 21. Encino Creek.  
Page 22. May Canyon.  
Pages 23 to 24. East Canyon.  
Page 25. Kagel Canyon.  
Page 26. Cooks Channel.  
Page 27. Pickens Canyon, plan A.  
Page 28. Pickens Canyon, plan B.  
Page 29. Gould and Paradise Canyons.

SAN GABRIEL RIVER BASIN

Pages 30 to 36. San Jose Creek.  
Pages 37 to 38. North Puente wash.

RIO HONDO BASIN

Page 39. Bradbury and Spinks Canyons.

FORMERLY TRIBUTARY TO LOS ANGELES RIVER

Pages 40 to 41. Laguna Dominguez (Nigger Slough).  
12. Estimates of cost.  
13. Economic analysis of flood-control improvements.  
Part I. Method employed.  
Part II. Application of method and description of overflow areas.  
Part III. Detailed analyses of benefits and costs.





WAR DEPARTMENT



LEGEND

- Boundary of Drainage Area
- Existing Water Supply Reservoir
- Flood Control Basin
- Debris Basin
- Channel

IMPROVEMENTS BY LOCAL INTERESTS

- Constructed by Los Angeles County Flood Control District and other agencies

IMPROVEMENTS BY WAR DEPARTMENT CORPS OF ENGINEERS

- Relief Project**
- Constructed under Emergency Relief Act approved July 10, 1935
- Existing Project**
- Authorized by Flood Control Act of June 22, 1936, as amended May 15, 1937, and as amended June 28, 1936
- Improvements Recommended**
- Extension of existing project
- Improvements Not Recommended**
- Additional Improvements considered but not recommended

LOS ANGELES AND SAN GABRIEL RIVERS & TRIBUTARIES, CALIFORNIA SURVEY FOR FLOOD CONTROL

GENERAL PLAN

SCALE IN MILES

U.S. ENGINEER OFFICE, LOS ANGELES, CALIF., JANUARY 1940  
DESIGNED BY *J. W. Anderson* APPROVED BY *W. H. ...*

FILE NO. 163/288 DRAWN BY *J. W. Anderson* CHECKED BY *J. W. Anderson* TO ACCOMPANY REPORT  
DATE: FEBRUARY 8, 1940

EXHIBIT 2

Interest on judgments.

SEC. 57. The last sentence of subsection (b) of section 2516 of Title 28, United States Code, is amended by inserting immediately after the word "allowed" where it appears in such sentence the words "for any period", so that such subsection will read as follows:

"(b) Interest on judgments against the United States affirmed by the Supreme Court after review on petition of the United States shall be paid at the rate of four percent per annum from the date of the filing of the transcript of the judgment in the Treasury Department to the date of the mandate of affirmance. Such interest shall not be allowed for any period after the term of the Supreme Court at which the judgment was affirmed."

Fees.

SEC. 58. Subsection (a) of section 2520 of Title 28, United States Code, is amended by striking out where it appears in such subsection the words "and the hearing of any case before the court, a judge, or a commissioner", so that such subsection will read as follows:

"(a) The Court of Claims shall by rules impose a fee not exceeding \$10, for the filing of any petition."

SEC. 59. (a) Chapter 165 of Title 28, United States Code, is amended by adding at the end thereof a new section to be designated as section 2521 entitled "Subpoenas" and to read as follows:

"§ 2521. Subpoenas

"Subpoenas requiring the attendance of parties or witnesses and subpoenas requiring the production of books, papers, documents or tangible things by any party or witness having custody or control thereof, may be issued for purposes of discovery or for use of the things produced as evidence in accordance with the rules and orders of the court. Such subpoenas shall be issued and served and compliance therewith shall be compelled as provided in the rules and orders of the court."

(b) The analysis to chapter 165 of Title 28, United States Code, immediately preceding section 2501 of such title, is amended by adding at the end thereof a new item 2521 to read as follows:

"2521. Subpoenas."

Approved September 3, 1954.

Public Law 780

CHAPTER 1264

AN ACT

September 3, 1954  
[H. R. 9859]

Authorizing the construction, repair, and preservation of certain public works on rivers and harbors for navigation, flood control, and for other purposes.

*Be it enacted by the Senate and House of Representatives of the United States of America in Congress assembled,*

River and Harbor  
Act of 1954.

TITLE I—RIVERS AND HARBORS

SEC. 101. That the following works of improvement of rivers and harbors and other waterways for navigation, flood control, and other purposes are hereby adopted and authorized to be prosecuted under the direction of the Secretary of the Army and supervision of the Chief of Engineers, in accordance with the plans and subject to the conditions recommended by the Chief of Engineers in the respective reports hereinafter designated: *Provided*, That the provisions of section 1 of the River and Harbor Act approved March 2, 1945 (Public, Numbered 14, Seventy-ninth Congress, first session), shall govern with respect to projects authorized in this title; and the procedures therein set forth with respect to plans, proposals, or reports for works of improvement for navigation or flood control and for irrigation and purposes incidental thereto, shall apply as if herein set forth in full:

59 Stat. 10.

Wisconsin.

Cornucopia Harbor, Wisconsin: House Document Numbered 434, Eighty-third Congress, at an estimated cost of \$220,000;

Sheboygan Harbor, Wisconsin: House Document Numbered 554, Eighty-second Congress, at an estimated cost of \$217,200;

Michigan.

Holland Harbor, Michigan: House Document Numbered 282, Eighty-third Congress, at an estimated cost of \$574,400: *Provided*, That local interests will contribute 25 per centum of the cost of dredging Section B, but not to exceed \$45,500, in addition to the local co-operation required by the project document;

Crooked and Indian Rivers, Michigan: House Document Numbered 142, Eighty-second Congress, at an estimated cost of \$225,000;

Saginaw River, Michigan: In accordance with the report of the Chief of Engineers, dated June 7, 1954, at an estimated cost of \$4,496,800;

Ohio.

Toledo Harbor, Ohio: House Document Numbered 620, Eighty-first Congress, at an estimated cost of \$512,000;

Ashtabula Harbor, Ohio: House Document Numbered 486, Eighty-third Congress, at an estimated cost of \$4,900,000;

Pennsylvania.

Erie Harbor, Pennsylvania: House Document Numbered 345, Eighty-third Congress, at an estimated cost of \$174,000;

New York.

Black Rock Channel and Tonawanda Harbor, New York: House Document Numbered 423, Eighty-third Congress, at an estimated cost of \$270,000;

Little River at Cayuga Island, Niagara Falls, New York: House Document Numbered 246, Eighty-third Congress, at an estimated cost of \$36,900;

Oswego Harbor, New York: House Document Numbered 487, Eighty-first Congress, at an estimated cost of \$2,459,000;

California.

Los Angeles and Long Beach Harbors, California: House Document Numbered 161, Eighty-third Congress, at an estimated cost of \$896,500: *Provided*, That the Secretary of the Army is hereby authorized to reimburse local interests for such work as they may have done upon this project prior to July 1, 1953, at actual cost to local interests insofar as the same shall be approved by the Chief of Engineers and found to have been done in accordance with the project hereby adopted: *Provided further*, That such reimbursement shall be subject to appropriations applicable thereto or funds available therefor and shall not take precedence over other pending projects of higher priority for harbor improvement: *And provided further*, That such payments shall not exceed the sum of \$500,000;

Playa del Rey Inlet and Harbor, Venice, California: House Document Numbered 339, Eighty-third Congress: *Provided*, That Federal participation in the provision of entrance jetties, entrance channel, interior channel and central basin recommended in the project report and presently estimated to cost \$7,738,000 shall not exceed 50 per centum of the cost thereof;

Port Hueneme, California: House Document Numbered 362, Eighty-third Congress, at an estimated cost of \$5,437,000;

Richmond Harbor, California: House Document Numbered 395, Eighty-third Congress, at an estimated cost of \$2,086,000;

Oregon.

Rogue River, Harbor at Gold Beach, Oregon: Senate Document Numbered 83, Eighty-third Congress, at an estimated cost of \$3,758,700;

Umpqua Harbor and River, Scholfield River at Reedsport, Oregon: Senate Document Numbered 133, Eighty-first Congress, at an estimated cost of \$41,000;

Tillamook Bay and Bar, Oregon: Senate Document Numbered 128, Eighty-third Congress, at an estimated cost of \$1,500,000;

Department of  
Beaches and Harbors

MAY 14 '03

|                         | Info | Act |
|-------------------------|------|-----|
| Director                |      |     |
| Chief City Director     |      |     |
| Deputy Director         |      |     |
| Executive Assistant     |      |     |
| Admin. Services         |      |     |
| Asset Management        |      |     |
| Facilities Property Mgt |      |     |
| Community Services      |      |     |
| Planning                |      |     |

PLAYA DEL REY INLET AND BASIN, VENICE, CALIF.

LETTER

FROM

THE SECRETARY OF THE ARMY

TRANSMITTING

A LETTER FROM THE CHIEF OF ENGINEERS, DEPARTMENT OF THE ARMY, DATED AUGUST 8, 1952, SUBMITTING A REPORT TOGETHER WITH ACCOMPANYING PAPERS AND AN ILLUSTRATION, ON A PRELIMINARY EXAMINATION AND SURVEY OF HARBOR AT PLAYA DEL REY, CALIF., AND A REVIEW OF REPORTS ON PLAYA DEL REY INLET AND BASIN, VENICE, CALIF., AS AUTHORIZED BY THE RIVER AND HARBOR ACT APPROVED ON AUGUST 26, 1937, AND REQUESTED BY A RESOLUTION OF THE COMMITTEE ON COMMERCE, UNITED STATES SENATE, ADOPTED ON JUNE 2, 1936

MAY 13, 1954.—Referred to the Committee on Public Works and ordered to be printed, with one illustration

DEPARTMENT OF THE ARMY,  
Washington 25, D. C., May 11, 1954.

The SPEAKER OF THE HOUSE OF REPRESENTATIVES.

DEAR MR. SPEAKER: I am transmitting herewith a report dated August 8, 1952, from the Chief of Engineers, Department of the Army, together with accompanying papers and an illustration, on a preliminary examination and survey of Harbor at Playa del Rey, Calif., and a review of reports on Playa del Rey Inlet and Basin, Venice, Calif., with a view to determining whether any improvement of the locality is warranted at the present time, authorized by the River and Harbor Act approved on August 26, 1937, and requested by a resolution of the Committee on Commerce, United States Senate, adopted on June 2, 1936.

In accordance with section 1 of Public Law 14, 79th Congress, the views of the State of California and the Department of the Interior are set forth in the enclosed communications.

The Bureau of the Budget advises that while there is no objection to submission of the report to Congress, authorization of the improvement recommended therein would not be in accord with the program of the President unless the Federal participation is limited to 50 percent of the cost of the general navigation facilities. The complete views of the Bureau of the Budget are contained in the attached copy of its letter.

Sincerely yours,

ROBERT T. STEVENS,  
*Secretary of the Army.*

COMMENTS OF THE BUREAU OF THE BUDGET

EXECUTIVE OFFICE OF THE PRESIDENT,  
BUREAU OF THE BUDGET,  
*Washington 25, D. C., April 28, 1954.*

The honorable the SECRETARY OF THE ARMY.

MY DEAR MR. SECRETARY: Your letter dated March 20, 1953, states that no modifications or revisions need be made from the standpoint of general policy or procedure in the 27 final proposed reports of the Chief of Engineers pending in the Bureau of the Budget on January 20, 1953. One of these is the report on the project at Playa del Rey, Calif. This report had been authorized by the River and Harbor Act approved on August 26, 1937, and requested by a resolution of the Committee on Commerce, United States Senate, adopted on June 2, 1936. Acting Secretary Johnson submitted the report to this office on August 19, 1952.

The Chief of Engineers recommends, subject to certain conditions of local cooperation, the provision of a harbor at Playa del Rey, Calif. First costs to the United States, including aids to navigation, are estimated at \$6,193,000 by the Board of Engineers for Rivers and Harbors. First costs to local interests are estimated at \$19,427,000. It is noted that the Board's estimate of \$25,620,000 for total first costs is based largely on cost estimates made in 1948. On this basis, annual costs are computed to be \$933,025. Annual benefits are estimated at \$1,296,000. The resulting benefit-cost ratio is 1.4.

The Chief of Engineers considers the proposed Federal participation in the project appropriate "if it is the intent of Congress to provide Federal assistance in the development of recreational boating facilities of the type proposed in this report."

The President in his 1955 budget message stated that, "to the greatest extent possible, the responsibility for resource development, and its cost, should be borne by those who receive the benefits." The benefits from Playa del Rey harbor evidently will be largely local in character. While it is recognized that under the proposed plan local interest will be required to spend large sums for lands,

piers, bulkheads, floats, paving, and other facilities, they would be making no contribution to the cost of the general navigation features of the project. The vessel berthing and shore works are items which traditionally have been furnished by local interests in the case of all navigation improvements to insure effective use of the facilities provided by the Federal Government.

We believe that the Federal share of the costs of all recreational harbors should be limited to not more than 50 percent of the first cost of providing the general navigation facilities. In the case of Playa del Rey the general facilities appear to include the jetties, entrance channel, interior channel, and central basin.

Accordingly, while there would be no objection to submission of the report on Playa del Rey Harbor to Congress, authorization of the improvement recommended therein would not be in accord with the program of the President unless the Federal participation is limited to 50 percent of the cost of the general navigation facilities.

Sincerely yours,

DONALD R. BELCHER, *Assistant Director.*

COMMENTS OF THE STATE OF CALIFORNIA

STATE OF CALIFORNIA  
DEPARTMENT OF PUBLIC WORKS,  
*Sacramento, June 26, 1952.*

Gen. LEWIS A. PICK,  
*Chief of Engineers,*  
*Department of the Army, Washington, D. C.*

DEAR SIR: Your proposed report on a review of reports on and preliminary examination and survey of Playa del Rey Inlet and Basin, Venice, Calif., was received on April 7, 1952, and transmitted on the same date to the division of water resources of this department for review and report thereon.

The report of the division of water resources has been received and is transmitted herewith in accordance with the provisions of Public Law 14, 79th Congress, 1st session.

I concur in the recommendations contained in the report of the division of water resources and it is requested that said report be considered as expressing the views and recommendations of the State of California on your proposed report on a review of reports on and preliminary examination and survey of Playa del Rey Inlet and Basin, Venice, Calif. It is further requested that the report of the division of water resources, dated June 26, 1952, on this subject be transmitted to the President of the United States and to the Congress along with the other material that may be so transmitted.

Very truly yours,

FRANK B. DURKEE,  
*Director of Public Works.*

REVIEW BY STATE DIVISION OF WATER RESOURCES OF PROPOSED REPORT OF THE CHIEF OF ENGINEERS, UNITED STATES ARMY, ON PLAYA DEL REY INLET AND BASIN, VENICE, CALIF.

INTRODUCTION

In accordance with the provisions of section 1 of Public Law 14, 79th Congress, the proposed report of the Chief of Engineers, United States Army, on Playa del Rey Inlet and Basin, Venice, Calif., together with the reports of the Board of Engineers for Rivers and Harbors and of the district and division engineers, was transmitted by the Chief of Engineers on March 31, 1952, to Mr. Frank B. Durkee, director of public works, the official designated by Gov. Earl Warren as his representative in such matters. The report was received and referred to the State engineer on April 7, 1952, for review and report thereon. Thereafter, the reports were transmitted by the State engineer to Seth Gordon, director, department of fish and game; Rufus W. Putnam, executive officer of the State lands commission; Newton B. Drury, chief, division of beaches and parks of the department of natural resources; and G. T. McCoy, State highway engineer.

Authority for report

The report was prepared pursuant to a resolution adopted June 2, 1936, which reads as follows:

Resolved by the Committee on Commerce of the United States Senate, That the Board of Engineers for Rivers and Harbors, created under section 3 of the River and Harbor Act approved June 13, 1902, be, and is hereby, requested to review the reports on Playa Del Rey Inlet and Basin, Venice, California, printed in House Document No. 1880, 64th Congress, 2d session, with a view to determining whether any improvement of the locality is warranted at the present time.

Further authorization was contained in Public Law 392, 75th Congress, approved August 26, 1937, which reads in part as follows:

Sec. 4: The Secretary of War is hereby authorized and directed to cause preliminary examinations and surveys to be made at the following-named localities, \* \* \* harbor at Playa Del Rey, California \* \* \*.

A review of reports on Playa del Rey Inlet and Basin, Venice, Calif., and preliminary examination of the harbor at Playa del Rey, Calif., dated May 26, 1939, was submitted by the district engineer in accordance with the foregoing authorizations. The district engineer's report was reviewed by the Board of Engineers for Rivers and Harbors, and a report of survey scope was authorized by the Chief of Engineers on April 6, 1944, to determine the advisability and cost of improvement and the local cooperation required.

Recommendations of the Chief of Engineers

The following is quoted from the proposed report of the Chief of Engineers now under review:

After full consideration of the reports secured from the district and division engineers, and after affording local interests full opportunity to be heard, the Board recommends provision of a harbor at Playa del Rey, Calif., to consist of 2 entrance jetties each about 2,300 feet long; an entrance channel 20 feet deep, 600 feet wide, and 1,925 feet long; an interior channel 20 feet deep, 600 feet wide, and 5,600 feet long; a central basin 10 feet deep; and 2 side basins 20 feet deep and 10 side basins 10 feet deep, separated by mole-type piers; the dredged material to be utilized for construction of the piers and for deposition on adjacent lowlands and beaches; all generally in accordance with the plan of the district engineer and the comments herein, and with such modifications thereof as in the discretion

of th  
Stat-  
subj  
the  
of th  
subs  
inter  
prop  
publ  
revel  
at B  
to th  
craft  
piers  
harb  
actu.  
proj  
entri  
and  
tena  
a pr  
stab.  
assis  
erosi  
cost  
3.  
need  
The  
gene  
the  
the l  
patit  
sider  
in th  
repo  
I fun  
shall  
with  
Des  
P  
Mo  
Har  
site  
of s  
con  
the  
I  
dred  
fille  
pro  
gat  
be  
the  
me  
in l  
side  
of l  
are  
of  
a p  
to l



of the Chief of Engineers may be advisable; at an estimated cost to the United States of \$6,151,000 for construction and \$25,000 annually for maintenance, subject to the condition that local interests agree to (a) provide without cost to the United States all rights-of-way necessary for construction and maintenance of the improvement and furnish suitable spoil-disposal areas for initial work and subsequent maintenance when and as required; (b) secure and hold in the public interest lands bordering on the proposed development to a width sufficient for proper functioning of the harbor; (c) relocate oil wells and relocate and construct public utilities as required; (d) construct a bulkhead around basin K and stone revetment on the side slopes of the remaining basins; (e) extend the north jetty at Ballona Creek to a length sufficient to hold the fill to be placed on the beach to the north thereof; (f) provide adequate berthing and other facilities for small craft; (g) provide adequate parking areas, access roads, and landscaping of the piers; (h) establish a public body to regulate the use and development of the harbor facilities which shall be open to all on equal terms; (i) dredge or bear the actual cost of dredging the 12 side basins; (j) maintain and operate the entire project except aids to navigation, entrance jetties, and project depths in the entrance channel, the interior channel, and in the central basin; and (k) hold and save the United States free from damages due to the construction and maintenance of the improvement; and also subject to the condition that adoption of a project as recommended shall not relieve local interests of responsibility for stabilization of beach fill along the shores of Santa Monica Bay with such Federal assistance as may be authorized following completion of the cooperative beach erosion control study now in progress. The local cooperation is estimated to cost \$19,427,000.

3. The proposed improvements are designed to meet recreational boating needs and are not significant from the standpoint of commercial navigation. The preponderance of benefits accruing to local interests as compared with general benefits of the type which warrant Federal participation is reflected in the relatively large non-Federal expenditures contemplated as compared with the proposed Federal costs. The proportion of Federal and non-Federal participation recommended by the Board of Engineers for Rivers and Harbors is considered appropriate if it is the intent of Congress to provide Federal assistance in the development of recreational boating facilities of the type proposed in this report. Subject to this, I concur in the views and recommendations of the Board. I further recommend that any authorizing legislation provide that construction shall not be initiated until conditions are such that the work will not interfere with the effort needed to meet existing and prospective emergency requirements.

#### *Description of area*

Playa del Rey is located in the central portion of the coast of Santa Monica Bay, about 26 miles upcoast by water from Los Angeles Harbor, and 3 miles downcoast from Santa Monica Harbor. The site proposed for the small craft harbor consists of about 1,200 acres of salt marshlands lying immediately north of the Ballona Creek flood-control channel and south of the Venice district. It is included within the incorporated area of the city of Los Angeles.

In 1903, as part of a real estate development, a series of canals was dredged in the Venice area. Many of these canals have since been filled and utilized for city streets, but the main canal still traverses the proposed harbor site, paralleling the coast and connecting with tide gates in the Ballona Creek channel. There is no navigable connection between the sloughs of the proposed harbor area and the ocean, and the Venice canals are utilized only by rowboats. The Federal Government completed the Ballona Creek flood-control channel and jetties in 1938. This trapezoidal channel is 200 feet wide, with stone paved sides on 1 on 3 slopes. The original random stone jetties at the mouth of the channel were extended by the city of Los Angeles in 1946, and are now about 1,350 feet in length. The harbor site includes a part of the Venice oilfield. Production from this field has declined from a peak exceeding 40,000 barrels per day in the discovery year of 1930 to about 2,300 barrels per day during 1946. About 40 wells have been

abandoned due to low production and salt-water intrusion, leaving 111 wells on low production.

Local interests consider that the proposed harbor at Playa del Rey would be an integral unit of an adopted general plan for development of the Santa Monica Bay shoreline. This plan includes widening and improving beaches, providing adequate bath houses, parking areas, picnic facilities, special recreation centers, bathing and wading beaches, fishing piers, youth organization camps, tourist parks with cabin and trailer accommodations, and a bird refuge.

*Cost of proposed works*

In the report of the district engineer, the total first cost of the project is given as \$25,603,000, with a Federal first cost of \$9,098,000 and non-Federal first cost of \$16,505,000. The total annual carrying charges would be \$919,920, and the annual benefits would be \$1,529,000. The benefit-cost ratio of the proposed harbor project would be 1.7 to 1.

The Board of Engineers for Rivers and Harbors, in reviewing the report of the district engineer, reevaluated the costs and benefits estimated by the district engineer. In considering both the evaluated and intangible benefits, the Board stated in its report that the Federal interest in the proposed improvement would be served by Federal participation to the extent of providing and maintaining the entrance jetties, entrance channel, interior channel, and central basin shown on the maps accompanying the district engineer's report, all at an estimated first cost of \$6,151,000 for construction exclusive of aids to navigation, and \$25,000 annually for maintenance, with local interests providing and maintaining all other works including dredging of the side basins at an estimated first cost of \$19,427,000.

The Board of Engineers for Rivers and Harbors also reduced the benefits allocated by the district engineer to sport fishing vessels from \$280,000 to \$47,000, making the total annual benefits \$1,296,000. Subsequent to the submission of the report by the district engineer, the United States Coast Guard submitted a revised estimate of \$42,000 for first cost of aids to navigation, an increase of \$17,000, making a total first cost of the project of \$25,620,000. The total annual carrying charges are estimated by the Board to be \$933,025, of which \$277,555 is Federal, and \$655,470 is non-Federal, giving a benefit-cost ratio of 1.4. The recommendation of the Board of Engineers for Rivers and Harbors as to Federal participation is concurred in by the Chief of Engineers.

*Local contributions*

At its meeting on April 25, 1946, the City Council of Los Angeles adopted a report declaring that the public interest and welfare of the city of Los Angeles and vicinity require the provision of additional small craft facilities by means of construction of a small craft harbor at Playa del Rey, assisting the Federal Government in such undertaking by assuming those obligations required under Federal law in connection with the project.

By resolution adopted September 28, 1948, and June 7, 1949, the Board of Supervisors of the County of Los Angeles declared that the public interest and welfare of the county of Los Angeles and its citizens require that provision be made for additional small craft facilities by means of construction of a small craft harbor at Playa del

l  
f  
o  
a  
p  
a  
w  
oi  
tc  
di  
pi  
an  
sr  
po  
of  
the  
fac  
Sta  
har  
tin  
f  
flo  
t  
tio  
che  
Ha  
par  
anc  
Ha  
cat  
to  
7  
Pla  
a re  
full  
Div  
T  
ing  
of t  
50  
the  
tigit

Rey. The Board agreed, insofar as it is authorized by law and the favorable vote of the electorate to do so, to assume the following obligations in connection with the Playa del Rey Harbor project:

- (1) Provide without cost to the United States all lands, easements, and rights-of-way for the construction and maintenance of the proposed improvements;
- (2) Hold and save the United States free from all claims for damages arising from the construction or operation of the improvement;
- (3) Assume the cost of alteration, relocation, or rebuilding of highways and highway bridges, or arrange for the alteration, relocation, or rebuilding of these highways and highway bridges without cost to the United States;
- (4) Assume the cost of relocation or reconstruction of utilities or drainage structures;
- (5) Contribute in cash or equivalent work, the cost of a steel sheet pile bulkhead and stone revetment required in the side basins;
- (6) Provide without cost to the United States all necessary slips and slip facilities and facilities for the repair, service, and supply of small craft on terms reasonable and equal to all;
- (7) Secure and hold for public interest lands bordering on the proposed improvement to a depth sufficient for the proper functioning of the harbor;
- (8) Furnish assurances satisfactory to the Secretary of War that the area will be improved by the construction of slips, utilities, repair facilities, and other appurtenant works, without cost to the United States and at a rate that will result in complete development of the harbor area within a reasonable time in accordance with plans and time schedules to be approved by the Secretary of War;
- (9) Assume the cost of extending the upcoast jetty at Ballona Creek flood-control channel.
- (10) Operate and maintain the entire project except aids to navigation, entrance jetties, and project depths in the entrance and interior channels, and in central basin.

According to the report of the Board of Engineers for Rivers and Harbors, local interests were advised of the reduction in financial participation by the Federal Government in the first cost of the project and, at a public hearing held by the Board of Engineers for Rivers and Harbors in the area of the desired improvement, local interests indicated they would endeavor to cooperate in the work of improvement to the extent considered necessary by the Board.

#### COMMENTS BY STATE AGENCIES

The proposed report of the Chief of Engineers on survey, navigation Playa del Rey Inlet and Basin, Venice, Calif., has been reviewed. As a result of this review and study, the following comments are respectfully submitted:

##### *Division of Water Resources*

The following is quoted from the district engineer's report concerning the effect of the construction of the project on saline contamination of the ground waters of the west coast basin:

50. *Saline contamination.*—An investigation was made concerning the effects of the proposed harbor on saline contamination of underground water. This investigation indicated that (1) sea water has already contaminated the ground water

within most of the area that would be occupied by the harbor: (2) further landward progress of this contamination depends primarily on the rate of withdrawal of ground water in the vicinity of the harbor site and on the steepness of the landward gradient produced by this withdrawal; and (3) introduction of sea water by constructing the harbor would not modify existing ground-water conditions.

Available information confirms conclusion No. 1 of the district engineer, as quoted above. Fieldwork in the area disclosed the following information:

1. Three active irrigation wells are situated within the perimeter of the proposed site. An additional 7 active irrigation wells are situated within 3,000 feet of the perimeter of the harbor. A total of 26 active irrigation wells are located within the area investigated, the most distant well being situated about 9,000 feet from the harbor perimeter.

2. Partial analyses of water samples obtained in April 1952 from 2 active water wells located within the perimeter of the proposed harbor show 640 and 486 parts per million chloride, respectively. The chloride content of ocean water is about 18,000 parts per million.

Water samples from 2 other active wells located within 2,000 feet of the perimeter contained 213 and 355 parts per million chloride, respectively. Samples from 2 more wells located 3,700 and 8,400 feet east of the eastern perimeter contained 216 and 284 parts per million chloride, respectively.

3. A rapid crop survey covering the area in the vicinity of the proposed Playa del Rey Harbor project indicates approximately 1,200 acres of truck crops are presently irrigated from wells. Based on an assumed consumptive-use factor of 1.7 acre-feet per acre and an assumed irrigation efficiency of 50 percent, annual consumption is about 2,000 acre-feet and well water production about 4,000 acre-feet per annum.

The district engineer's quoted conclusion No. 2 is likewise believed to be essentially correct concerning the present situation. Saline contamination of ground water in the Playa del Rey area was first noted in wells near the ocean in the 1920's. Coincident with increased pumping draft in the west coast basin, accompanied by further lowering of the water table below sea level, the saline intrusion progressively moved inland until by 1945-46 the limit of 500 parts per million of chloride contamination was from 1½ to 2 miles from the ocean in the Playa del Rey area.

Water level measurements in Ballona Gap in the spring of 1950 indicated the water table to be sloping inland from the coastline with a maximum gradient of about 6 feet per mile.

The proposed harbor overlies an important aquifer known as the "50-foot gravel," so named because the average depth of its base is about 50 feet below ground surface. In the vicinity of the site of the harbor the top of this aquifer is 40 to 45 feet below land surface. A study of the logs of 14 wells located within one-half mile of the perimeter of the harbor site indicates the aggregate thickness of relatively impervious material contained in the sediments overlying the aquifer to vary from 0 to 16 feet. Average aggregate thickness of clay above the aquifer is about 9 feet. In general, a large percentage of the impermeable material above the 50-foot gravel occurs near the land surface.

The General Plan of Improvement (enclosure 1 of the report) indicates dredgings to a depth of 20 feet below sea level, representing excavation to a total depth of roughly 25 feet below the present land

surface. Such dredging will obviously decrease the thickness of impermeable material lying between the floor of the harbor and the top of the water-bearing zone, thereby decreasing the resistance offered to the percolation of sea water into the aquifer.

From the foregoing observations, it is believed that the quoted conclusion No. 3 of the district engineer is contrary to what may be expected if the harbor is constructed, and that construction of the harbor would aggravate the present conditions of sea-water intrusion and endanger the water quality of wells located near its perimeter in the following ways:

1. By reducing (through dredging) the thickness of relatively impermeable materials which lie between the surface and the top of the 50-foot gravel aquifer.

2. By increasing the landward slope of the water table and consequently the rate of landward flow of saline water. This slope would be increased as a result of moving the shoreline inland through construction of the harbor.

3. By decreasing the lateral distance that sea water must travel to reach producing wells.

It is believed that if this project is pursued, the ruination of water wells in the immediate vicinity of the harbor should be contemplated. However, the present landward sloping water table indicates that the threat of ocean water pollution already exists at these wells. Also, lands presently irrigated in the vicinity are rapidly being subdivided, and these subdivisions are being served with domestic water imported from outside sources. For these reasons, and because of the probable increase in property values due to the harbor project, ultimate benefits may offset the possible damage to the limited ground-water supply.

#### *Division of Highways*

G. T. McCoy, State highway engineer, by communication dated June 11, 1952, submitted the following:

State highway routes will not be directly affected by the recommended plan of the harbor improvement. The proposed development plan of the local planning commission includes provisions for access parkway facilities which will cross and connect with U. S. 101, State Route 60. It is understood that such development involving interchanges or alterations affecting the State highway will be undertaken as part of the obligations of the local interests without commitment of the Division of Highways to costs thereof. The Division of Highways' attitude with respect to the project will, we assure you, be cooperative.

#### *State Lands Commission*

Col. Rufus W. Putnam, executive officer of the State Lands Commission, submitted the following comments on April 15, 1952:

The jurisdiction of the tide and submerged lands adjacent to the proposed harbor development is in the city of Los Angeles by legislative grant. No State lands under the jurisdiction of the State Lands Commission are affected by the proposed development.

#### *Department of Fish and Game*

Seth Gordon, director, Department of Fish and Game, by communication dated June 6, 1952, submitted the following:

We do not believe the project would have any harmful effect on the fisheries. However, the benefit figures given for sport-fishing operations (p. 33) are optimistic. Operations at Playa del Rey would draw fishermen away from other landings rather than add new fishermen, it is believed.

It would affect a small waterfowl marsh.

*Department of Natural Resources*

Newton B. Drury, chief, Division of Beaches and Parks of the Department of Natural Resources, on June 18, 1952, stated that the thoughts expressed in the comments previously submitted to the district engineer on January 6, 1949 still reflect the reaction of the division to the project.

The comments, submitted by Gen. Warren T. Hannum, director of natural resources, on January 6, 1949, are as follows:

(a) It is found that plan of development as proposed in the district engineer's report would provide a greatly needed harbor for light craft vessels, and as a harbor refuge for such craft cruising along the coast.

(b) That the proposed harbor development is in general in conformity with the county master plan as approved by the State Park Commission.

(c) That there is no State cooperation proposed in the plan, the city of Los Angeles having expressed its desire and willingness to meet the requirements of local cooperation as set forth by the district engineer.

(d) That the incidental benefits to the State park system, due to the deposit of sand on the beaches both upcoast and downcoast from the proposed entrance jetties would be very great.

It is recommended therefore, that the report be approved with a favorable comment indicating the advantages to the State park system from the deposit of sand on the Santa Monica beaches.

CONCLUSIONS

The following conclusions are submitted with respect to improvements recommended by the Chief of Engineers in his proposed report on Playa del Rey Inlet and Basin, Venice, Calif., giving consideration to (a) need for the project (b) engineering feasibility and effectiveness of the proposed works, and (c) economic justification for the project:

1. The improvements will provide a desirable addition to small-craft facilities along the southern California coast. The project is an integral part of the general plan for development of the shoreline of Santa Monica Bay.

2. Local interest in and approval of the project have been demonstrated by resolution of the city council of the city of Los Angeles, and by resolution of the Board of Supervisors of the County of Los Angeles, giving assurance that the county will assume those non-Federal contributions and obligations in connection with the project which are required by Federal law.

3. The improvements appear to be of sound and adequate design and feasible of construction and operation.

4. Construction of the proposed harbor will introduce ocean water inland a distance of more than 1 mile, and increase the rate of saline contamination of ground waters of the west coast basin. Except in this respect, the proposed works will not conflict with any beneficial consumptive use, present or future, of water for domestic, municipal, stock water, irrigation, mining, or industrial purposes.

RECOMMENDATIONS

It is recommended that the plan of improvement for the small-craft harbor at Playa del Rey Inlet and Basin, Venice, Calif., as recommended by the Chief of Engineers, be authorized for construction, and that Federal funds be appropriated for the purpose.

SACRAMENTO, CALIF., June 26, 1952.

A. D. EDMONSTON,  
*State Engineer.*

I  
M  
cc  
C  
of  
en  
un  
th  
dit  
pr  
im  
nel  
of  
be  
\$2:  
int  
7  
cra  
ben  
anr  
des  
Fec  
for  
and  
Riv  
red  
only  
dou  
to l  
Fed  
W  
that  
sour  
proj  
graf  
and  
inter  
recre  
SI  
plan  
com  
Fede  
polic  
Engi  
of th  
tion

## COMMENTS OF THE DEPARTMENT OF THE INTERIOR

UNITED STATES DEPARTMENT OF THE INTERIOR,  
OFFICE OF THE SECRETARY,  
Washington 25, D. C., July 25, 1952.

Lt. Gen. LEWIS A. PICK,  
*Chief of Engineers, Department of the Army,  
Washington, D. C.*

MY DEAR GENERAL PICK: This is in response to your letter of March 31 transmitting for review by the Department of the Interior copies of your proposed report on the Playa del Rey Inlet and Basin, Calif. Your letter also transmitted copies of the reports of the Board of Engineers for Rivers and Harbors and of the district and division engineers.

Your proposed report recommends that the Federal Government undertake the construction of a harbor at Playa del Rey, Calif., for the use of small boats, subject to deferment of construction until conditions are such that the project would not interfere with existing or prospective emergency requirements on the national economy. The improvement would consist of two entrance jetties, an entrance channel, an interior channel, a central basin, 12 side basins, and a number of piers. The cost to the United States of the improvement would be \$6,151,000 for construction, exclusive of aids to navigation, and \$25,000 annually for maintenance. The construction cost to local interests for the improvement would total an additional \$19,427,000.

The harbor would be built almost wholly for the benefit of pleasure craft owned by private individuals in the Los Angeles area. The benefits from the construction of the harbor are shown to be \$1,529,000 annually in the report of the district engineer, of which \$805,000 are designated as "general (Federal) benefits" and \$724,000 as local (non-Federal) benefits. Those benefits classed as Federal consist of \$450,000 for recreational harbor benefit, \$75,000 for prevention of boat damage, and \$280,000 for increased fish catch. The Board of Engineers for Rivers and Harbors, however, finds the latter figure excessive and reduces it in the Board's report to \$47,000. In our view this is the only legitimate Federal benefit from the project. We have serious doubts that prevention of boat damage or recreational harbor benefits to local boatowners can be classed by any stretch of logic as "general Federal benefits."

We note that the proposed report of the Chief of Engineers indicates that the Department of the Army also has serious question as to the soundness of a policy of spending Federal funds on a single-purpose project primarily for the benefit of local pleasure craft owners. Paragraph 3 of this proposed report states that the proportion of Federal and non-Federal participation is considered appropriate "if it is the intent of Congress to provide Federal assistance in the development of recreational boating facilities of the type proposed in this report."

Should the proposed project be constructed in accordance with the plan presented in the report, it can be expected that hundreds of other communities will seek the same type of project with comparable Federal participation. It therefore seems to us important that a policy covering this point with respect to projects of the Corps of Engineers be clearly established. It is suggested that the final draft of the report of the Chief of Engineers contain a suitable recommendation on this matter.

Paragraph 49 of the district engineers report covers the effect of the harbor improvement on wildlife resources. It is noted that the Fish and Wildlife Service of this Department in a letter of April 26, 1946, indicated that no objection will be interposed to construction of the project on account of the elimination of certain wildlife habitat. The district engineer also received a letter from the regional director of the Fish and Wildlife Service dated September 14, 1949, commenting on the project. It is suggested that these letters from a part of the enclosures accompanying the survey report when it is transmitted to the Bureau of the Budget and to the Congress. I endorse the position taken in these communications to the district engineer from the Fish and Wildlife Service.

Opportunity to review and comment on the reports is sincerely appreciated.

Sincerely yours,

MASTIN G. WHITE,  
*Acting Secretary of the Interior.*

REPORT OF THE CHIEF OF ENGINEERS, DEPARTMENT OF THE  
ARMY

DEPARTMENT OF THE ARMY,  
OFFICE OF THE CHIEF OF ENGINEERS,  
*Washington 25, D. C., August 8, 1952.*

Subject: Playa del Rey Inlet and Basin, Venice, Calif.

To: The Secretary of the Army.

1. I submit herewith for transmission to Congress the report of the Board of Engineers for Rivers and Harbors in response to resolution of the Committee on Commerce of the United States Senate, adopted June 2, 1936, requesting the Board to review the reports on Playa del Rey Inlet and Basin, Venice, Calif., printed in House Document No. 1880, 64th Congress, 2d session, with a view to determining whether any improvement of the locality is warranted at the present time. It is also in review of the reports on preliminary examination and survey of harbor at Playa del Rey, Calif., authorized by the River and Harbor Act approved August 26, 1937.

2. After full consideration of the reports secured from the district and division engineers, and after affording local interests full opportunity to be heard, the Board recommends provision of a harbor at Playa del Rey, Calif., to consist of 2 entrance jetties each about 2,300 feet long; an entrance channel 20 feet deep, 600 feet wide, and 1,925 feet long; an interior channel 20 feet deep, 600 feet wide, and 5,600 feet long; a central basin 10 feet deep; and 2 side basins 20 feet deep and 10 side basins 10 feet deep, separated by mole-type piers; the dredged material to be utilized for construction of the piers and for deposition on adjacent lowlands and beaches; all generally in accordance with the plan of the district engineer and the comments herein, and with such modifications thereof as in the discretion of the Chief of Engineers may be advisable; at an estimated cost to the United States of \$6,151,000 for construction and \$25,000 annually for maintenance, subject to the condition that local interests agree to: (a) provide without cost to the United States all rights-of-way necessary for construction and maintenance of the improvement and furnish suitable spoil-disposal areas for initial work and subsequent main-

1  
t  
a  
t  
c  
in  
d  
te  
(  
er  
te  
U  
te  
ad  
of  
M  
ing  
in  
:  
bo  
cia  
int  
Fe  
exp  
cos  
rec  
con  
Fec  
of t  
vie  
any  
init  
with  
requ

REF

Subj  
To:  
1.  
adof  
Re:  
Boar  
and I  
the r  
Docu  
any in



tenance when and as required; (b) secure and hold in the public interest lands bordering on the proposed development to a width sufficient for proper functioning of the harbor; (c) relocate oil wells and relocate and construct public utilities as required; (d) construct a bulkhead around basin K and stone revetment on the side slopes of the remaining basins; (e) extend the north jetty at Ballona Creek to a length sufficient to hold the fill to be placed on the beach to the north thereof; (f) provide adequate berthing and other facilities for small craft; (g) provide adequate parking areas, access roads, and landscaping of the piers; (h) establish a public body to regulate the use and development of the harbor facilities which shall be open to all on equal terms; (i) dredge or bear the actual cost of dredging the 12 side basins; (j) maintain and operate the entire project except aids to navigation, entrance jetties, and project depths in the entrance channel, the interior channel, and in the central basin; and (k) hold and save the United States free from damages due to the construction and maintenance of the improvement; and also subject to the condition that adoption of a project as recommended shall not relieve local interests of responsibility for stabilization of beach fill along the shores of Santa Monica Bay with such Federal assistance as may be authorized following completion of the cooperative beach-erosion-control study now in progress. The local cooperation is estimated to cost \$19,427,000.

3. The proposed improvements are designed to meet recreational boating needs and are not significant from the standpoint of commercial navigation. The preponderance of benefits accruing to local interests as compared with general benefits of the type which warrant Federal participation is reflected in the relatively large non-Federal expenditures contemplated as compared with the proposed Federal costs. The proportion of Federal and non-Federal participation recommended by the Board of Engineers for Rivers and Harbors is considered appropriate if it is the intent of Congress to provide Federal assistance in the development of recreational boating facilities of the type proposed in this report. Subject to this, I concur in the views and recommendations of the Board. I further recommend that any authorizing legislation provide that construction shall not be initiated until conditions are such that the work will not interfere with the effort needed to meet existing and prospective emergency requirements.

LEWIS A. PICK,

*Lieutenant General, Chief of Engineers.*

REPORT OF THE BOARD OF ENGINEERS FOR RIVERS AND HARBORS

CORPS OF ENGINEERS, UNITED STATES ARMY,  
BOARD OF ENGINEERS FOR RIVERS AND HARBORS,  
*Washington 25, D. C., October 30, 1951.*

Subject: Playa del Rey Inlet and Basin, Venice, Calif.

To: The Chief of Engineers, Department of the Army.

1. This report is submitted in response to the following resolution adopted June 2, 1936:

*Resolved by the Committee on Commerce of the United States Senate, That the Board of Engineers for Rivers and Harbors, created under section 3 of the River and Harbor Act approved June 13, 1902, be, and is hereby, requested to review the reports on Playa del Rey Inlet and Basin, Venice, Calif., printed in House Document No. 1880, 64th Congress, 2d session, with a view to determining whether any improvement of the locality is warranted at the present time.*

It is also in review of the reports on preliminary examination and survey of harbor at Playa del Rey, Calif., authorized by the River and Harbor Act approved August 26, 1937.

2. Playa del Rey is on Santa Monica Bay on the coast of California, 20 miles northwest of Los Angeles Harbor. The proposed harbor site consists largely of salt marsh and lowlands traversed by a number of canals and sloughs with depths varying from 2 to 10 feet below mean lower low water. It is separated from Santa Monica Bay by a narrow beach. There is no navigable outlet from the proposed harbor site to Santa Monica Bay. Ballona Creek flows through an artificial channel along the southerly side of the proposed harbor. A tide gate connecting the interior canals and sloughs with Ballona Creek provides a drainage outlet through Ballona Creek and inlet to Santa Monica Bay. The mean range of tide in Santa Monica Bay is 3.7 feet and the extreme range is 10.5 feet. The Venice district of the city of Los Angeles adjoins the proposed harbor on the north. There is no existing Federal project for improvement for navigation at Playa del Rey. There is, however, an existing Federal flood-control project for Ballona Creek which forms part of a comprehensive approved plan for flood control and other purposes for Los Angeles County drainage area, California. It includes construction of channel improvements along Ballona Creek; 2 stone jetties extending into the ocean for approximately 800 feet; highway and railroad bridges; and a tide gate connecting the proposed harbor site with Ballona Creek. Construction of these improvements was completed in 1940. In 1946 the city of Los Angeles extended the jetties 580 feet in connection with a beach-widening program. In times past, local interests constructed canals in the Venice area, constructed sheet-pile jetties on each side of the Ballona Inlet, and made an unsuccessful attempt to dredge an interior basin.

3. The general tributary area, which includes all of metropolitan Los Angeles, is bounded by a line extending from Oxnard through Bakersfield and Bishop, Calif., to Tonopah and Las Vegas, Nev., and back through Needles and Beaumont to San Clemente, Calif. The immediate tributary area comprises 638 square miles of metropolitan Los Angeles extending from the Pacific Ocean to the San Gabriel Mountains and from San Fernando Valley to El Segundo. The estimated population of this immediate area was 2,307,725 in 1946, including 1,522,702 within the city limits of Los Angeles. Principal activities are petroleum production and refining, motion-picture production, manufacturing, and farming. A part of the proposed harbor would extend over the Del Rey Hills and Venice areas of the Playa del Rey oilfield. There is no water borne freight traffic and no terminal or transfer facility at Playa del Rey. Row-boats are used occasionally on the canals within the proposed harbor site. The region is served by railroads and highways.

4. Local interests request provision by the United States of a harbor for small craft at Playa del Rey as part of a comprehensive plan for park and beach development including recreational boating facilities. Various specific requests were advanced by local interests in connection with the plan of improvement but these evolved during the course of the investigation to substantially the plan presented by the district engineer. Local interests point out the need for adequate facilities for small craft in the Santa Monica Bay area and nearby districts,

the ov  
recreat  
favora  
fits to l

5. T  
faciliti  
Santa  
Califor  
tributa  
of the l  
of the t  
out tha  
exceed  
percent  
tion is  
needs o  
capacit  
will be  
Basing  
within t  
of whic  
Angeles  
that th  
provem  
trict en  
4,000 cr  
cost esti  
c. pacit  
based u  
remaini  
this ad  
that the  
for mak  
able to  
states tl  
continue

6. Th  
struction  
5,600 fe  
channel  
basin 10  
feet dee  
done by  
construc  
beaches.  
proposec  
\$9,073,0  
the non-  
including  
struction  
revetme  
developr  
tional pi  
The Fed

the overcrowding in existing harbors, the desirability of separating recreational boating areas from commercial and naval waters, and the favorable economic effect of such an improvement including the benefits to be derived from land reclamation.

5. The district engineer finds there is need for additional harbor facilities for small craft in southern California, particularly in the Santa Monica Bay area. He estimates that, on the basis of the California average of 2.79 boats per 1,000 population, the immediate tributary area would sustain about 6,500 small craft, and on the basis of the Los Angeles average of 1.6 per 1,000 population, the remainder of the tributary area would sustain an additional 960 craft. He points out that the number of craft using the harbor probably would greatly exceed these figures inasmuch as the tributary area contains a high percentage of persons most able to own small craft, and the population is steadily increasing. He concludes that the present and future needs of the tributary area require an improvement with an ultimate capacity of 8,000 craft and estimates that half the ultimate capacity will be reached within 5 years after construction of the improvement. Basing his calculations upon the distribution of existing boatowners within the area, he estimates 1,000 would transfer from other harbors, of which 20 would be from Santa Monica Harbor, 400 from Los Angeles Harbor, and 580 from Newport Bay Harbor. He estimates that the remaining 7,000 would be new vessels. Although the improvement is designed for an ultimate capacity of 8,000 craft, the district engineer conservatively bases the estimate of benefits on the 4,000 craft expected to be realized a few years after construction. His cost estimates are based upon construction to provide for the ultimate capacity of 8,000 craft, except that the costs for berthing facilities are based upon construction of the initial 4,000 berths. The cost of the remaining 4,000 berths will be more than offset by the benefits from this additional number of boats. The district engineer considers that the proposed improvement at Playa del Rey is the most suitable for making recreational harbor facilities in Santa Monica Bay available to the largest number of boatowners at the least cost. He states that recovery of petroleum from the existing oilfield could be continued by relocating the wells.

6. The district engineer's plan of improvement provides for construction of an entrance channel 1,925 feet long and an interior channel 5,600 feet long, each 20 feet deep and 600 feet wide, the entrance channel to be protected by 2 jetties, each 2,300 feet long; a central basin 10 feet deep; 2 side basins 20 feet deep and 10 side basins 10 feet deep, separated by mole-type piers; and for certain work to be done by local interests. The dredged material would be used to construct the mole-type piers and to reclaim adjacent lowlands and beaches. The district engineer estimates the total first cost of the proposed plan at \$25,603,000, of which the Federal first cost is \$9,073,000 for construction and \$25,000 for aids to navigation; and the non-Federal first cost is \$16,505,000 for lands and rights-of-way including disposal areas, relocation of oil wells, relocation and construction of public utilities, construction of a bulkhead and stone revetments, provision of berthing and other facilities for small craft, development of the area surrounding the harbor for park and recreational purposes, and extension of the north jetty at Ballona Creek. The Federal annual carrying charge is estimated at \$395,550, including

\$25,000 for annual maintenance of the 2 entrance jetties and of project depths in the entrance and interior channels and in the central basin. The net non-Federal annual carrying charge is estimated at \$524,370 after deducting \$190,600, returns from slip rentals. The total annual carrying charge is \$919,920. The district engineer estimates the average annual benefits from the proposed improvement at \$1,529,000, comprising \$215,000 from land enhancement due to fill, \$16,000 from decreased cost of mosquito control, \$280,000 from increased fish catch from sport fishing activities, \$75,000 from prevention of storm damage to small craft, \$43,000 from decreased automobile travel and decreased boat maintenance resulting from transfer of vessels from distant harbors, and \$900,000 from recreational benefits to owners of new vessels. The benefit-cost ratio is 1.7. The district engineer recommends adoption of a project to establish a harbor in accordance with his proposed plan subject to the conditions that local interests give assurances satisfactory to the Secretary of the Army that they will secure and hold in the public interest lands bordering on the proposed development to a width sufficient for proper functioning of the harbor; provide without cost to the United States rights-of-way, including disposal areas; assume the cost of relocating oil wells and the cost of relocating and constructing public utilities; construct a bulkhead around one basin and stone revetment on the side slopes of the remaining basins; extend the north jetty at Ballona Creek; provide adequate berthing and other facilities for small craft; develop the harbor area for park and recreational purposes; establish a public body empowered to regulate the use, growth, and free development of the harbor facilities, open to all on equal and reasonable terms; prepare definite plans and schedules for construction of small craft facilities, subject to approval by the Secretary of the Army; maintain and operate the entire project, except entrance jetties, project depths in the entrance and interior channels and in the central basin, and aids to navigation; and hold and save the United States free from all claims for damages arising from construction or operation of the project. The division engineer concurs.

7. With respect to the effect of the improvement on adjacent shorelines, the district engineer finds that the shores of Santa Monica Bay down coast of the Santa Monica breakwater have been deprived of normal littoral nourishment since construction of the breakwater in 1933, and that the Playa del Rey jetties, 3 miles south of the breakwater, would act as a complete littoral barrier and would benefit the shore to the north. The plan of improvement proposed by the district engineer provides for deposition of 10,130,000 cubic yards of material, dredged from the harbor, on the beaches immediately up-coast of the Playa del Rey jetties and downcoast between Playa del Rey and Ballona Creek jetties, and deposition of 3,200,000 cubic yards of material downcoast of the Ballona Creek jetties. Disposal of the dredged material on the downcoast beaches as proposed would provide adequate nourishment for many years, and thereafter the beaches can be maintained in their advanced position by mechanical bypassing of material, a method now being considered in a cooperative beach erosion control study between the United States and the State of California. The Beach Erosion Board concurs in the conclusions of the district engineer as to the effect of the proposed improvement on the adjacent shorelines. It points out that adoption of the project

as recommended shall not relieve local interests of responsibility for stabilization of beach fill along the shores of Santa Monica Bay with such Federal assistance as may be authorized following completion of the cooperative beach erosion control study now in progress.

8. The Board of Engineers for Rivers and Harbors was not convinced of the advisability of the United States participating in the improvement to the extent recommended by the reporting officers and questioned whether local interests were in agreement as to operational control and sponsorship of the improvement. The Board so notified local interests and they requested a public hearing. At the hearing held by the Board in the area of the desired improvement, local interests indicated they would endeavor to cooperate in the work of improvement to the extent considered necessary by the Board and would agree among themselves in the matter of operational control and sponsorship of the improvement. The commander, 11th Coast Guard District, stated in a communication that a harbor at Playa del Rey would serve as a refuge, would make available a harbor from which Coast Guard patrol and rescue craft could operate, and would tend to relieve the congestion and contribute to general maritime safety in the Los Angeles-Long Beach area. Subsequent to the public hearing, the Hughes Aircraft Co. advised the Board that the proposed improvement would interfere with a contemplated expansion of its facilities and a proposed runway extension. The company was given an opportunity to furnish information in support of its claim but no evidence of importance has been received. The Board also requested the views of the Department of the Air Force and the Civil Aeronautics Administration concerning the claim of the Hughes Co. A communication from the Office, Deputy Chief of Staff, Department of the Air Force, states that the present plans of the Air Force do not contemplate expansion of the Hughes Co. which would result in conflict with the proposed harbor improvement for Playa del Rey, Calif. The Deputy Administrator of Civil Aeronautics, Civil Aeronautics Administration, states in a communication that study by its regional office reveals that no aircraft operation difficulties or conflicts will result by the development and operation of the proposed improvement.

IEWS AND RECOMMENDATIONS OF THE BOARD OF ENGINEERS FOR  
RIVERS AND HARBORS

9. The Board of Engineers for Rivers and Harbors concurs in the views of the reporting officers that a need exists for a harbor with an ultimate capacity of 8,000 small craft in the vicinity of Playa del Rey, Calif. The plan recommended by the district engineer together with work to be performed by local interests will provide a suitable improvement. Total prospective benefits are sufficient to justify the expenditure required. The Board believes that in addition to the evaluated benefits resulting directly from construction of the small-boat harbor, benefits would accrue to local interests from the use of the area as a park facility. It can be expected that the area will be visited and enjoyed by many persons in no way connected with small-boat commerce. Considering both the evaluated and intangible benefits, the Board is of the opinion that the Federal interest in the proposed improvement would be served by Federal participation to

the extent of providing and maintaining the entrance jetties, entrance channel, interior channel, and central basin shown on the maps accompanying the district engineer's report, all at an estimated first cost of \$6,151,000 for construction exclusive of aids to navigation, and \$25,000 annually for maintenance, with local interests providing and maintaining all other works including dredging of the side basins at an estimated first cost of \$19,427,900. Local interests state they will meet the requirements of local cooperation as indicated by the Board. Benefits from 35 sport fishing vessels are estimated by the district engineer as \$280,000, which is \$8,000 per vessel. Basing its conclusions on investigations of this type of fishing, the Board finds that a total of \$47,000 is more reasonable. The total annual benefits would then amount to \$1,296,000. The Board of Engineers for Rivers and Harbors has carefully considered the data presented by the district engineer and Beach Erosion Board with respect to the effect of the improvement on the adjacent shoreline. It is of the opinion—after taking into account the stabilizing effect on the upcoast beaches, the effect of the existing Ballona Creek jetties, and the deposition on adjacent beaches of approximately 13,330,000 cubic yards of material dredged from the harbor, including the deposition of 3,200,000 cubic yards downcoast of the Ballona Creek jetties—that the beneficial effects to the adjacent shoreline would more than offset any adverse effects that would occur. The Board agrees with the Beach Erosion Board that accomplishment of the improvement shall not modify the relative responsibility of local interests and the United States in connection with any work which may be authorized for stabilization of adjacent beaches following completion of the cooperative beach erosion control study now in progress. Subsequent to submission of the report by the district engineer the United States Coast Guard submitted a revised estimate of \$42,000 for the first cost of aids to navigation, an increase of \$17,000. The total first cost then becomes \$25,620,000. With the distribution of costs as proposed by the Board, including the new estimate for aids to navigation, the total annual carrying charge becomes \$933,025 of which \$277,555 is Federal and \$655,470 is non-Federal. The benefit-cost ratio is 1.4.

10. The Board accordingly recommends provision of a harbor at Playa del Rey, Calif., to consist of 2 entrance jetties each about 2,300 feet long; an entrance channel 20 feet deep, 600 feet wide, and 1,925 feet long; an interior channel 20 feet deep, 600 feet wide, and 5,600 feet long; a central basin 10 feet deep; and 2 side basins 20 feet deep and 10 side basins 10 feet deep, separated by mole-type piers; the dredged material to be utilized for construction of the piers and for deposition on adjacent lowlands and beaches; all generally in accordance with the plan of the district engineer and the comments herein, and with such modifications thereof as in the discretion of the Chief of Engineers may be advisable; at an estimated cost to the United States of \$6,151,000 for construction and \$25,000 annually for maintenance, subject to the condition that local interests agree to: (a) provide without cost to the United States all rights-of-way necessary for construction and maintenance of the improvement and furnish suitable spoil-disposal areas for initial work and subsequent maintenance when and as required; (b) secure and hold in the public interest lands bordering on the proposed development to a width sufficient for proper functioning of the harbor; (c) relocate oil wells and relocate

and construct public utilities as required; (d) construct a bulkhead around basin "K" and stone revetment on the side slopes of the remaining basins; (e) extend the north jetty at Ballona Creek to a length sufficient to hold the fill to be placed on the beach to the north thereof; (f) provide adequate berthing and other facilities for small craft; (g) provide adequate parking areas, access roads, and landscaping of the piers; (h) establish a public body to regulate the use and development of the harbor facilities which shall be open to all on equal terms; (i) dredge or bear the actual cost of dredging the 12 side basins; (j) maintain and operate the entire project except aids to navigation, entrance jetties, and project depths in the entrance channel, the interior channel, and in the central basin; and (k) hold and save the United States free from damages due to the construction and maintenance of the improvement; and also subject to the condition that adoption of a project as recommended shall not relieve local interests of responsibility for stabilization of beach fill along the shores of Santa Monica Bay with such Federal assistance as may be authorized following completion of the cooperative beach erosion control study now in progress.

For the Board:

G. J. NOLD,  
Major General, Chairman.

## REPORT OF THE DISTRICT ENGINEER

### SYLLABUS

The district engineer finds that there is need for additional small-craft facilities at Santa Monica Bay. He finds that the provision of such facilities at Playa del Rey is practicable, that the site is the one most suitable for construction of a small-craft harbor near the Los Angeles metropolitan area, and that the facilities would be used to capacity.

The district engineer estimates the tangible benefits at \$1,529,000 a year and the large intangible benefits would accrue. He estimates the total first cost of project at \$25,603,000 (including \$25,000 costs to the United States Coast Guard for aids to navigation), and the annual charges at \$919,920. The benefit-to-cost ratio would be 1.7 to 1.

The district engineer recommends that a project be adopted to establish a harbor for small-craft navigation at Playa del Rey, Calif., to consist of two harbor entrance jetties; an entrance channel 600 feet wide and 20 feet deep; an interior channel 600 feet wide, 5,600 feet long, and 20 feet deep; 2 side basins 20 feet deep; a central basin and 10 side basins 10 feet deep separated by mole-type piers; deposition of dredged material in the mole-type piers, on adjacent lowlands, along beach frontage; all at an estimated Federal first cost of \$9,073,000, exclusive of aids to navigation, and \$25,000 annually for maintenance; subject to the condition that local interests shall give assurances satisfactory to the Secretary of the Army that the required cooperation will be furnished, such cooperation to be performed by a competent and duly authorized public body, especially able to accomplish the obligations so assumed and empowered to regulate the use, growth, and free development of the harbor facilities with the understanding that such facilities shall be open to all on equal terms. The required local cooperation would consist of: (1) Securing and holding in the public interest, lands bordering on the proposed development to a width sufficient for proper functioning of the harbor; assuming the cost of all rights-of-way, filling disposal areas, the cost of relocating oil wells, and the cost of relocating and constructing public utilities; constructing stone revetments, a vertical bulkhead, and an extension of the upcoast jetty at Ballona Creek flood-control channel; providing adequate facilities for operating, berthing, maintaining, repairing, and supplying small craft; and for developing the harbor area for park and recreational purposes, all at an estimated non-Federal first cost of \$16,505,000; preparing definite plans and construction schedules for the construction of

small-craft facilities, including development of the mole-type piers, which shall be subject to approval by the Secretary of the Army; (3) maintaining and operating the entire project except aids to navigation, entrance jetties, and project depths in the entrance and interior channels and in the central basin; and (4) holding and saving the United States free from all claims for damages arising from the construction or operation of the project works.

DEPARTMENT OF THE ARMY,  
CORPS OF ENGINEERS,  
LOS ANGELES DISTRICT,  
Los Angeles, Calif., August 16, 1948.

Subject: Survey of harbor at Playa del Rey, Calif.  
Through: Division engineer, South Pacific Division, Oakland, Calif.  
To: The Chief of Engineers, Department of the Army.

#### AUTHORITY

1. This report is submitted pursuant to a resolution adopted June 2 1936, which reads as follows:

Resolved by the Committee on Commerce of the United States Senate, That the Board of Engineers for Rivers and Harbors, created under section 3 of the River and Harbor Act approved June 13, 1902, be, and is hereby, requested to review the reports on Playa Del Rey Inlet and Basin, Venice, Calif., printed in House Document No. 1880, 64th Congress, 2d session, with a view to determining whether any improvement of the locality is warranted at the present time—

and to River and Harbor Act, Public Law 392, 75th Congress, approved August 26, 1937, which reads in part as follows:

SEC. 4. The Secretary of War is hereby authorized and directed to cause preliminary examinations and surveys to be made at the following-named localities,  
\* \* \*:

\*            \*            \*            \*            \*            \*            \*  
Harbor at Playa Del Rey, Calif.  
\*            \*            \*            \*            \*            \*            \*

(In accordance with United States Geological Survey maps and with local usage, the harbor under consideration is designated in this report as Playa del Rey.)

2. A review of reports on Playa del Rey Inlet and Basin, Venice, Calif., and preliminary examination of harbor at Playa del Rey, Calif., dated May 26, 1939, submitted by the district engineer in accordance with the resolution and act quoted above, was reviewed by the Board of Engineers for Rivers and Harbors. This report of survey scope was authorized by the Chief of Engineers in letter of April 6, 1944, to determine the advisability and cost of improvement and the local cooperation required.

#### DESCRIPTION

3. *Charts and maps.*—Playa del Rey inlet and vicinity are shown on United States Coast and Geodetic Survey charts 5101 and 5144; on Venice Quadrangle, United States Geological Survey of 1923; and on maps, enclosures 5<sup>1</sup> and 6<sup>1</sup> of this report.

4. *General.*—Playa del Rey is located in the central part of Santa Monica Bay on the coast of southern California, 26 miles by water northwesterly (upcoast) from Los Angeles Harbor, 3 miles southeasterly (downcoast) from Santa Monica Harbor, and about 410 miles southeasterly of San Francisco Bay. The Venice district, a seaside resort annexed to the city of Los Angeles in November 1925, adjoins the proposed harbor area on the north. The business center

<sup>1</sup> Not printed.



of the city of Los Angeles is 15 miles inland to the east. A considerable portion of the area immediately north of Ballona Creek consists of the Venice Slough and canals which drain into the ocean through the outlet of Ballona Creek flood-control channel. This area comprises about 1,513 acres of salt marsh and low farm and residential lands located in the area between the Venice district and the Ballona Creek flood-control channel, and between United States Highway 101 Alternate (Lincoln Boulevard) and the Pacific Ocean. The farm and residential land, except the strip of residential and commercial property adjacent to the beach, is subject to flooding by moderate rainfall. The farmland is along the west side of Highway U. S. 101 Alternate, and the residential property is concentrated along the shoreline and between Washington Street and Venice Boulevard. The salt-marsh area comprises about 1,200 acres.

5. *Depth of water.*—The water depths in the canals and in the connecting sloughs vary from 2 feet to 10 feet below mean lower low water. The elevation of the salt-marsh area averages about 3 feet above mean lower low water.

6. *Tides.*—In Santa Monica Bay the mean tide range is 3.7 feet, the diurnal range is 5.6 feet, and the extreme range is about 10.5 feet.

7. *Exposure and weather.*—Severe ocean winds are rare in the immediate vicinity, as in all southern California coastal waters. Offshore ocean storms of varying intensities occur generally during the period December to March, inclusive, and may cause large ground swells. The ocean front is unprotected except to a small degree by Point San Vicente and by Santa Catalina Island (approximately 30 miles offshore) on the south, and by the trend of the coast and by Point Dume on the northwest. Prevailing winds are principally westerly and southwesterly and seldom attain storm violence, as indicated by the wind rose on map, enclosure 1. During the winter southerly offshore winds occasionally cause destructive wave action.

8. In general, the climate is mild and uniform. A summary of average annual wind and weather conditions and a tabulation showing the number of days each month during 1944 and 1945 that small-craft warnings were posted for the area is given in the following tables.

Average annual meteorological conditions in vicinity of Playa del Rey Harbor, Calif.

| Month          | Sun-<br>shine<br>(per-<br>cent) | True wind velocity<br>(miles per hour)  |                                        |                               |                                                    | Number of days— |                  |        |                                                         |                        |              |    |
|----------------|---------------------------------|-----------------------------------------|----------------------------------------|-------------------------------|----------------------------------------------------|-----------------|------------------|--------|---------------------------------------------------------|------------------------|--------------|----|
|                |                                 | Aver-<br>age<br>hourly<br>veloc-<br>ity | Pre-<br>vail-<br>ing<br>direc-<br>tion | Max-<br>imum<br>veloc-<br>ity | Direc-<br>tion of<br>maxi-<br>mum<br>veloc-<br>ity | Clear           | Partly<br>cloudy | Cloudy | With<br>precipi-<br>tation<br>(0.01<br>inch or<br>more) | Thun-<br>der<br>storms | Dense<br>fog |    |
| January.....   | 70                              | 6.1                                     | NE                                     | 38                            | NE                                                 | 15              | 9                | 7      | 6                                                       | (0)                    |              | 1  |
| February.....  | 68                              | 6.6                                     | NE                                     | 34                            | NW                                                 | 13              | 8                | 7      | 6                                                       | (0)                    |              | 2  |
| March.....     | 68                              | 6.2                                     | SW                                     | 37                            | SW                                                 | 13              | 10               | 8      | 6                                                       | 1                      |              | 2  |
| April.....     | 68                              | 6.0                                     | SW                                     | 34                            | W                                                  | 12              | 11               | 7      | 4                                                       | (0)                    |              | 2  |
| May.....       | 65                              | 5.9                                     | SW                                     | 30                            | W                                                  | 11              | 14               | 6      | 2                                                       | (0)                    |              | 2  |
| June.....      | 70                              | 5.7                                     | SW                                     | 28                            | SW                                                 | 13              | 14               | 2      | 1                                                       | (0)                    |              | 3  |
| July.....      | 78                              | 5.6                                     | SW                                     | 21                            | SW                                                 | 16              | 14               | 1      | (0)                                                     | (0)                    |              | 3  |
| August.....    | 79                              | 5.5                                     | SW                                     | 25                            | SE                                                 | 19              | 11               | 1      | 1                                                       | (0)                    |              | 3  |
| September..... | 77                              | 5.4                                     | SW                                     | 31                            | S                                                  | 17              | 11               | 2      | 2                                                       | (0)                    |              | 3  |
| October.....   | 76                              | 5.5                                     | SW                                     | 28                            | NE                                                 | 18              | 9                | 4      | 3                                                       | (0)                    |              | 2  |
| November.....  | 79                              | 5.8                                     | NE                                     | 35                            | NE                                                 | 18              | 8                | 4      | 3                                                       | (0)                    |              | 2  |
| December.....  | 73                              | 6.2                                     | NE                                     | 35                            | NE                                                 | 17              | 8                | 6      | 6                                                       | (0)                    |              | 1  |
| Year.....      | 72                              | 5.9                                     | W                                      |                               |                                                    | 182             | 127              | 56     | 37                                                      | 5                      |              | 27 |

<sup>1</sup> Less than 1 day.

Small-craft storm warnings posted

| Month               | Year— |      |
|---------------------|-------|------|
|                     | 1944  | 1945 |
|                     | Days  | Days |
| January.....        | 6     | 3    |
| February.....       | 10    | 6    |
| March.....          | 3     | 6    |
| April.....          | 6     | 5    |
| May.....            | 3     | 0    |
| June.....           | 1     | 0    |
| July.....           | 0     | 0    |
| August.....         | 0     | 0    |
| September.....      | 2     | 1    |
| October.....        | 0     | 2    |
| November.....       | 6     | 6    |
| December.....       | 6     | 8    |
| Total for year..... | 43    | 37   |

14. The number of small-craft storm warnings posted in the metropolitan area

Number of small

|                    |  |
|--------------------|--|
| Long Beach.....    |  |
| Los Angeles.....   |  |
| Newport Bay.....   |  |
| Redondo Beach..... |  |
| Santa Monica.....  |  |
| Alamitos Bay.....  |  |
| Total.....         |  |

<sup>1</sup> Estimated by Long Beach Harbor Department.  
<sup>2</sup> Exclusive of about 100 boats.

9. *Navigation.*—There is no navigable connection between the ocean and the Venice canals and connecting sloughs. The ocean outlet is through a steel and concrete tide gate which connects the canals with the Ballona Creek flood-control channel. The canals are occasionally navigated only by small rowboats.

10. The only natural harbor in the southern California area is San Diego Bay, 133 miles to the south. Newport Bay Harbor was created in the tidal outlet of Santa Ana River by diverting the river from the harbor, dredging, and constructing jetties at the harbor entrance. This port is used primarily for recreational craft but has limited facilities for commercial fishing.

11. Los Angeles and Long Beach Harbors are two of the principal Pacific coast commercial harbors. During the war years, 1941-45, many owners of small craft who had been using these harbors were required to find mooring facilities in other harbors. The harbor departments of both Los Angeles and Long Beach are reluctant to assign space to smallcraft and do so only on short-time leases subject to cancellation. The operation of small craft in a commercial and naval harbor is hazardous to the small craft and is a nuisance to the commercial or naval interests.

12. Redondo Beach Harbor has a partially sheltered area of about 20 acres but this area is exposed to southerly storms. Boats anchoring in this harbor are extensively damaged each year.

13. Santa Monica Harbor, which originally comprised 92 acres, is now shoaled to 46 acres. The harbor area is partially protected by an offshore breakwater which was constructed by local interests in 1934. This breakwater has not been maintained and has deteriorated to a considerable extent. About 64 fishing boats and 21 recreational craft are moored within the lee of the breakwater. Because of insufficient mooring space and the poor protection afforded during storms, over 100 small boats are stored on the adjacent Santa Monica pier and several fishing boats anchor outside the breakwater. Boat losses in the harbor have been high in the past years, and marine-insurance agencies are very reluctant to insure boats anchored there. The master plan for shoreline development of Los Angeles County provides for removal of the existing breakwater at Santa Monica Harbor.

15. *General tributary area.*—The Los Angeles metropolitan area includes the area enclosed by a line from Bishop, Calif., to Needles and Beaumont.

16. *Immediate tributary area.*—The Los Angeles metropolitan area includes the area enclosed by a line from the Pacific to the San Fernando Valley. It includes the cities of Burbank, Culver City, Monrovia, Monterey Park, San Gabriel, San Marino, and part of the city of Hollywood. North Hollywood comprises 16 per cent of the population of the metropolitan area. The population of the immediate tributary area is approximately 1,000,000.

<sup>1</sup> Not printed.

14. The number of small craft moored at harbors in the Los Angeles metropolitan area are shown in the following table:

*Number of small craft in Los Angeles metropolitan area, California (1946)*

| Harbor             | Number of pleasure craft | Number of commercial fishing craft | Total            |
|--------------------|--------------------------|------------------------------------|------------------|
| Long Beach.....    | 285                      | <sup>1</sup> 100                   | <sup>1</sup> 385 |
| Los Angeles.....   | 779                      | 272                                | 1,051            |
| Newport Bay.....   | 1,888                    | 600                                | 2,488            |
| Redondo Beach..... | 0                        | 50                                 | 50               |
| Santa Monica.....  | 21                       | 64                                 | <sup>2</sup> 85  |
| Alamitos Bay.....  | 0                        | 0                                  | 0                |
| Total.....         | 2,973                    | 1,086                              | 4,059            |

<sup>1</sup> Estimated by Long Beach Harbor Department.

<sup>2</sup> Exclusive of about 100 boats stored on pier and several fish boats moored outside breakwater.

#### TRIBUTARY AREA

15. *General tributary area.*—The area generally tributary to the proposed harbor at Playa del Rey is shown on enclosure 6.<sup>1</sup> The tributary area includes all of metropolitan Los Angeles and the entire area enclosed by a line extending from Oxnard through Bakersfield and Bishop, Calif., to Tonopah and Las Vegas, Nev., and back through Needles and Beaumont to San Clemente, Calif.

16. *Immediate tributary area.*—The area immediately tributary to Playa del Rey, comprising about 638 square miles, is that part of metropolitan Los Angeles which lies closer to the proposed harbor than to any other existing or proposed harbor. In general, this area extends from the Pacific Ocean to the San Gabriel Mountains, and from the San Fernando Valley to El Segundo, shown as zone 1 on enclosure 5.<sup>1</sup> It includes the cities of Arcadia, Alhambra, Beverly Hills, Burbank, Culver City, El Monte, El Segundo, Glendale, Inglewood, Monrovia, Monterey Park, Pasadena, South Pasadena, San Fernando, San Gabriel, San Marino, Santa Monica, Sierra Madre, and Vernon, and part of the city of Los Angeles with its suburbs of Van Nuys, Hollywood, North Hollywood, and West Los Angeles. This area comprises 16 percent of Los Angeles County, contains 67 percent of the population of the county, and contributes 60 percent of the county tax. The population of cities and unincorporated areas of the immediate tributary area is shown in the following tables:

<sup>1</sup> Not printed.

## Population of cities in the immediate tributary area

| City                                | 1930 census | Percent gain | 1940 census | Percent gain | 1945 estimate <sup>1</sup> | Approximate distance from Playa del Rey |
|-------------------------------------|-------------|--------------|-------------|--------------|----------------------------|-----------------------------------------|
|                                     |             |              |             |              |                            | Miles                                   |
| Arcadia.....                        | 5,216       | 74.9         | 9,122       | 53.5         | 14,003                     | 35                                      |
| Alhambra.....                       | 29,472      | 32.1         | 38,935      | 10.9         | 43,174                     | 23                                      |
| Beverly Hills.....                  | 17,429      | 53.9         | 26,823      | 5.2          | 28,217                     | 10                                      |
| Burbank.....                        | 16,662      | 106.1        | 34,337      | 80.2         | 61,859                     | 24                                      |
| Culver City.....                    | 5,669       | 58.3         | 8,976       | 51.3         | 13,580                     | 5                                       |
| El Monte.....                       | 3,479       | 35.4         | 4,746       | 33.8         | 6,349                      | 28                                      |
| El Segundo.....                     | 3,503       | 6.7          | 3,738       | 52.8         | 5,710                      | 3                                       |
| Glendale.....                       | 62,736      | 31.6         | 82,582      | 14.0         | 94,134                     | 26                                      |
| Inglewood.....                      | 19,480      | 54.6         | 30,114      | 32.9         | 40,034                     | 6                                       |
| Los Angeles.....                    | 1,195,205   | 21.5         | 1,342,885   | 13.4         | 1,522,702                  | 13                                      |
| Van Nuys <sup>2</sup> .....         |             |              | 20,298      | 32.0         | 26,784                     | 17                                      |
| Hollywood <sup>3</sup> .....        |             |              | 142,262     | 10.7         | 157,491                    | 15                                      |
| North Hollywood <sup>4</sup> .....  |             |              | 24,449      | 48.0         | 38,179                     | 20                                      |
| West Los Angeles <sup>4</sup> ..... |             |              | 58,690      | 27.2         | 74,649                     | 7                                       |
| Monrovia.....                       | 10,809      | 17.6         | 12,807      | 37.5         | 14,863                     | 37                                      |
| Monterey Park.....                  | 6,406       | 33.2         | 8,531       | 20.6         | 10,291                     | 23                                      |
| Pasadena.....                       | 76,088      | 7.6          | 81,864      | 9.7          | 89,789                     | 25                                      |
| South Pasadena.....                 | 13,730      | 4.6          | 14,356      | 10.6         | 15,880                     | 22                                      |
| San Fernando.....                   | 7,567       | 20.2         | 9,094       | 13.6         | 10,332                     | 30                                      |
| San Gabriel.....                    | 7,224       | 64.3         | 11,867      | 25.0         | 14,828                     | 26                                      |
| San Marino.....                     | 3,730       | 119.2        | 8,175       | 29.6         | 10,598                     | 26                                      |
| Santa Monica.....                   | 37,146      | 44.0         | 53,500      | 18.5         | 63,398                     | 5                                       |
| Sierra Madre.....                   | 3,550       | 29.0         | 4,581       | 20.7         | 5,529                      | 35                                      |
| Vernon.....                         | 1,269       | -33.0        | 850         | 13.0         | 961                        | 18                                      |
| Total.....                          | 1,436,368   | 23.9         | 1,807,961   | 15.5         | 2,088,839                  |                                         |

<sup>1</sup> Estimate by Los Angeles County Regional Planning Commission.<sup>2</sup> Includes the population of only that part of the city of Los Angeles in zone 1.<sup>3</sup> Included in population figures for Los Angeles.

## Population in unincorporated areas in the immediate tributary area

| Area                                        | 1940 census | Percent gain | 1945 estimate <sup>1</sup> | Approximate distance from Playa del Rey |
|---------------------------------------------|-------------|--------------|----------------------------|-----------------------------------------|
|                                             |             |              |                            | Miles                                   |
| Belvedere and East Los Angeles.....         | 71,541      | 12.2         | 80,289                     | 20                                      |
| Burbank and Glendale <sup>2</sup> .....     | 11,866      | 25.5         | 15,007                     | 25                                      |
| El Monte and San Gabriel <sup>3</sup> ..... | 52,585      | 35.9         | 71,459                     | 25                                      |
| Pasadena <sup>4</sup> .....                 | 32,419      | 28.4         | 40,990                     | 28                                      |
| West Los Angeles.....                       | 6,361       | 75.1         | 11,141                     | 7                                       |
| Total.....                                  | 174,752     | 25.2         | 218,886                    |                                         |
| Total for cities.....                       | 1,807,961   | 15.5         | 2,088,839                  |                                         |
| Grand total (zone 1).....                   | 1,982,713   | 16.4         | 2,307,725                  |                                         |

<sup>1</sup> Estimate by Los Angeles County Regional Planning Commission.<sup>2</sup> Area includes districts of La Crescenta, Verdugo City, Montrose, and La Canada.<sup>3</sup> Area includes districts of Temple City, Wilmar, Rosemead, Potrero Heights, Garvey, and Duarte.<sup>4</sup> Area includes districts of Altadena and Lamanda Park.

17. The 1945 assessed valuation of taxable property in the immediate tributary area, as shown on the records of the Los Angeles County assessor, is given in the following table:

## Assessed valuation of property in the immediate tributary area

| Location                  | Type of property |              |             | Total         |
|---------------------------|------------------|--------------|-------------|---------------|
|                           | Land             | Improvements | Personal    |               |
| Arcadia.....              | \$4,820,780      | \$6,725,120  | \$861,460   | \$12,407,360  |
| Alhambra.....             | 10,579,815       | 14,271,120   | 4,105,710   | 28,956,645    |
| Beverly Hills.....        | 25,332,255       | 27,456,200   | 5,959,080   | 58,747,545    |
| Burbank.....              | 14,737,325       | 28,135,030   | 21,234,340  | 64,216,695    |
| Culver City.....          | 3,671,565        | 6,536,090    | 9,930,650   | 20,138,305    |
| El Monte.....             | 1,261,355        | 1,498,600    | 236,500     | 3,046,455     |
| El Segundo.....           | 2,476,770        | 12,286,020   | 4,109,895   | 18,872,685    |
| Glendale.....             | 23,689,455       | 31,945,810   | 5,217,345   | 65,852,610    |
| Inglewood.....            | 8,956,325        | 12,097,180   | 1,900,030   | 22,953,535    |
| Los Angeles (zone 1)..... | 509,057,855      | 431,732,610  | 133,171,255 | 1,073,961,720 |
| Monrovia.....             | 2,837,655        | 3,553,520    | 1,034,990   | 7,426,165     |
| Monterey Park.....        | 2,065,530        | 2,296,610    | 297,840     | 4,659,980     |
| Pasadena.....             | 32,955,175       | 34,308,160   | 9,330,755   | 76,594,090    |
| South Pasadena.....       | 4,121,025        | 4,965,440    | 708,630     | 9,795,095     |
| San Fernando.....         | 1,928,710        | 2,019,710    | 481,590     | 4,429,010     |
| San Gabriel.....          | 3,432,360        | 5,508,330    | 685,450     | 9,626,140     |
| San Marino.....           | 6,459,050        | 9,985,800    | 1,759,740   | 18,204,590    |
| Santa Monica.....         | 19,860,570       | 21,445,290   | 5,638,245   | 46,944,105    |
| Sierra Madre.....         | 1,203,055        | 1,436,220    | 231,390     | 2,870,665     |
| Vernon.....               | 9,994,525        | 15,743,190   | 31,486,950  | 57,224,665    |
| Total.....                | 694,539,165      | 673,916,050  | 238,451,845 | 1,606,907,060 |
| Unincorporated areas..... | 74,316,165       | 60,804,135   | 29,660,565  | 164,780,865   |
| Grand total.....          | 768,855,330      | 734,720,185  | 268,112,400 | 1,771,687,915 |

18. *Occupations, resources, and industries.*—The principal industries in the area immediately tributary to Playa del Rey are petroleum production and refining; motion picture production; airplane construction; automobile assembly; manufacture of tires and rubber goods, furniture, and apparel; and agriculture. Statistical data are not available for the gross value of manufacturing and agriculture in the immediate tributary area. However, the entire county of Los Angeles contributes toward the support of each small-craft harbor within the metropolitan area, and Playa del Rey would receive its share. The gross output for Los Angeles County in 1939 was in excess of \$3,800 million from industry and commerce and \$76 million from agriculture. Data subsequent to 1939 were not available because of wartime restrictions.

19. *Transportation.*—The tributary area is served by the Southern Pacific, Union Pacific, Pacific Electric, and the Atchison, Topeka & Santa Fe Railroads, and by 1 foreign and 4 domestic passenger airlines and 6 freight airlines. The harbor site is served by the Pacific Electric Railway and by municipal and Pacific Electric buslines connecting Playa del Rey with the beach cities and with the center of Los Angeles. United States Highway No. 101 Alternate (Lincoln Blvd.) and several secondary highways pass through the proposed harbor area and connect with the network of State, county, and city highways.

20. *Bridges.*—There are no bridges, existing or planned, in the area of the proposed harbor at Playa del Rey. Several bridges crossing the Ballona Creek flood-control channel are planned by local interests as a part of the park development outside the harbor area.

## PRIOR REPORTS

21. The only published report concerning harbor improvements in the vicinity of Playa del Rey is listed in the following table:

List of prior reports

| Report                                                                       | Published as—                          | Recommendation                          |
|------------------------------------------------------------------------------|----------------------------------------|-----------------------------------------|
| Preliminary examination of Playa del Rey Inlet and Basin dated Nov. 4, 1916. | H. Doc. No. 1890, 64th Cong., 2d sess. | Improvement not advisable at that time. |

## OTHER IMPROVEMENTS

22. *Navigation.*—Navigation improvements in the area resulted from early attempts by local interests to create a commercial harbor at Playa del Rey and from the construction of canals as a part of a real estate development. In 1887 the Ballona Harbor Improvement Co. constructed sheet-pile jetties on each side of the inlet and attempted to dredge an interior basin. The dredge was inadequate and the enterprise was abandoned.

23. Beginning in 1903 the Beach Land Co. dredged a series of canals in the Venice area and constructed tide gates in the inlet. After the tide gates were destroyed by storms many of the canals were artificially filled to create city streets in lieu of the canals which had failed to attain popularity.

24. *Flood control.*—The Federal Government completed the Ballona Creek flood-control channel and jetties in 1938. This project was constructed in part under the Emergency Relief Act of 1935 and the remainder under the Flood Control Act approved June 22, 1936. The lower reach of the flood-control channel constitutes the southerly boundary of the proposed harbor area. In this section the channel is trapezoidal, 200 feet wide at the bottom with side slopes of 1 on 3. The side slopes are paved with one-man stone supported by a fill of dumped stone at the toe of paving. The invert is not paved. The jetties at the entrance are random stone, and the voids between the stones above mean lower low water have been filled with concrete to a depth of 3 feet. The jetties as originally constructed were about 775 feet long, measured from mean high-tide line, and are 340 feet from centerline to centerline. The jetties were extended 580 feet in 1946 by the city of Los Angeles. The crest width is 16 feet and the elevation at the crest is 13 feet above mean lower low water. The side slopes are 1 on 1.5. A steel and concrete tide gate was installed to connect the main Venice canal with the flood-control channel. The cost of Ballona Creek Channel (including entrance jetties and tide gate) was about \$7 million.

25. *Petroleum production.*—In 1930 an oilfield was discovered in this area and about 151 producing wells have been drilled. The field has been in production continuously since that time. In recent years salt water has encroached in the field and production has been reduced so that about 40 wells have been abandoned, leaving only 111 on low production. The daily production of the entire field is reported to have been 2,300 barrels during 1946, whereas the peak daily production exceeded 40,000 barrels in November 1930. A part of the proposed

harbor area would be over the Venice area of the Playa zone, the lower zone, is pre-older ocean front area, production and from a relatively slow acquisition of all oil rights is considered, it would be feasible to production to continue in the harbor function. In the interest it would be more desirable to from offset wells equipped to abandon the field. Local investment of the oil rights.

26. *Proposed shoreline improvement.*—A bond issue of \$10 million, the area, and the State of California total of \$21 million, which will complete sewage-treatment plant, sewage treatment plant and outfall sewer. The site for the sewage treatment has excavated 14,100,000 cubic feet on the beach between Ocean This resulted in a general widening of that distance. The deposit step in the overall plan for the Ballona Creek jetties 580 feet outlet from the shoaling cause

27. Local interests consider Playa del Rey would be an integral unit of the Santa Monica Bay shoreline. Local interests include the following: beaches, adequate bathhouse, special recreation centers, salt-water pools, fishing piers, youth cabin and trailer accommodations, the wildlife now inhabiting the highways along the improved completed plans for the construction to facilitate access to the beach would avoid the congested met the distance to be traveled and beach recreation and park area Playa del Rey from any localities. 28. The city of Los Angeles, New York City to prepare an economic purposes on the entire beach harbor, at a cost of \$35,000.

## TERMINAL AND

29. There are no terminal facilities at Playa del Rey, 30. Santa Monica Harbor, 3. at Playa del Rey, has terminal facilities for commercial fishing and recreational

harbor area would be over the Del Rey Hills area and the ocean front or Venice area of the Playa del Rey oilfield. Only one productive zone, the lower zone, is present in the Del Rey Hills area. In the older ocean front area, production is obtained both from the lower zone and from a relatively shallow zone, the upper zone. Although acquisition of all oil rights in fee within the proposed harbor was considered, it would be feasible to redrill a part of the wells and to allow production to continue in those wells that would not interfere with the harbor function. In the interest of conservation of mineral resources, it would be more desirable to continue petroleum recovery by redrilling from offset wells equipped with low-height surface pumps than to abandon the field. Local interests do not anticipate difficulty in settlement of the oil rights.

26. *Proposed shoreline improvements.*—The city of Los Angeles voted a bond issue of \$10 million, to which other cities in the metropolitan area and the State of California have added \$11 million, making a total of \$21 million, which will be used for the construction of a complete sewage-treatment plant at Hyperion to replace the present screening plant and outfall sewer. In connection with the preparation of the site for the sewage-treatment plant, the city of Los Angeles has excavated 14,100,000 cubic yards of dune sand, and has deposited it on the beach between Ocean Park and El Segundo (about 5.5 miles). This resulted in a general widening of the beach about 450 feet throughout that distance. The deposit of this material constitutes the initial step in the overall plan for beach improvement. The city extended the Ballona Creek jetties 580 feet seaward to protect the flood-control outlet from the shoaling caused by the new beach fill.

27. Local interests consider that the proposed harbor at Playa del Rey would be an integral unit of the plan for the development of the Santa Monica Bay shoreline. The plan of development proposed by local interests includes the following features: Widened and improved beaches, adequate bathhouses and parking areas, picnic facilities, special recreation centers, salt-water bathing pools and children's wading pools, fishing piers, youth organization camps, tourist parks with cabin and trailer accommodations, and a bird sanctuary to perpetuate the wildlife now inhabiting the area. In addition to scenic and through highways along the improved beach front, local authorities also have completed plans for the construction of a highway and freeway system to facilitate access to the beach areas. The proposed freeway system would avoid the congested metropolitan areas and would shorten both the distance to be traveled and the time required to reach the proposed beach recreation and park area and the proposed harbor facilities at Playa del Rey from any locality within the immediate tributary area.

28. The city of Los Angeles has employed a consulting firm of New York City to prepare an economic analysis and report for financing purposes on the entire beach development, including the proposed harbor, at a cost of \$35,000.

#### TERMINAL AND TRANSFER FACILITIES

29. There are no terminal or transfer facilities at Playa del Rey.

30. Santa Monica Harbor, 3 miles upcoast from the proposed harbor at Playa del Rey, has terminal and transfer facilities for small commercial fishing and recreational craft at the municipal pier. This pier

is partially protected by the Santa Monica breakwater. The breakwater has deteriorated to such an extent that the harbor probably would be abandoned if facilities for small craft are constructed at Playa del Rey. The construction of additional terminal facilities in Santa Monica Bay is impracticable because of the unprotected shoreline.

## EXISTING PROJECT

31. There has never been a Federal navigation project at Playa del Rey.

## IMPROVEMENTS DESIRED

32. *Public hearings.*—Two public hearings were held in Venice, Calif., by the district engineer to consider the advisability of improving Playa del Rey, one on July 29, 1936, and the other on August 12, 1938, in connection with the preliminary examination report. The hearings were attended by public officials, real estate and other business interests, and representatives of various civic organizations, as well as the general public.

33. *Improvements desired by local interests.*—At the public hearing on August 12, 1938, the Regional Planning Commission of Los Angeles County and local civic organizations requested that a small-craft harbor be provided at Playa del Rey by the United States. The improvements desired by the regional planning commission consisted of (1) extending the jetties of the Ballona Creek flood-control outlet a distance of 800 feet; (2) constructing 2 jetties 1,475 feet in length to provide a second entrance to the interior basin; (3) dredging an interior basin about 1 square mile in area to a depth of 15 feet below mean lower low water, connected by an entrance channel to Ballona Creek flood-control channel; (4) dredging the Ballona Creek entrance and the second entrance to a depth of 15 feet below mean lower low water; (5) constructing secondary roads, miscellaneous drainage structures, and utilities; (6) constructing boat facilities and recreational park improvements; and (7) purchasing rights-of-way and land. The total cost estimated by local interests in 1938 was \$9,750,000.

34. *Local interests' justification of the desired project.*—Local interests are unanimous in desiring improvement of Playa del Rey Inlet and Basin for small-craft navigation. They offer the following considerations in support of the navigation improvements.

(a) There is need for added mooring space for small craft in Santa Monica Bay, in view of the increasing scarcity of small-craft anchorage areas in Los Angeles Harbor and because of the inconvenience attending the use of that harbor.

(b) The desired improvements are required for recreation and small-craft boating by people living in the northern part of Los Angeles County, which includes the heavily-populated Los Angeles city area, as well as Hollywood, Beverly Hills, Culver City, Inglewood, Santa Monica, and other suburban districts.

(c) The improvement would be an effective aid in the development of the boatbuilding industry.

(d) The improvement would satisfy an increasing need for small-craft facilities, create a widespread economic benefit through an increase in permanent employment and in business, and cause an increase in values of both real estate and other property, thereby increasing the tax base.



(e) Indirect benefits would accrue from reclaiming a large swamp area, which would result in an improvement of conditions affecting public health and in the stimulation of development of 5 or 6 square miles of partially developed land. The development of these areas would increase the taxable wealth.

35. Small-craft owners in the Los Angeles metropolitan area state that the proposed harbor at Playa del Rey is required because of unsatisfactory conditions in Los Angeles and Long Beach Harbors, such as overcrowding of available space, decrease in number of berths because of increasing commercial and naval requirements, short-term leases, high maintenance costs, long distances from the ocean, and inadequate automobile parking facilities.

#### COMMERCE AND VESSEL TRAFFIC

36. *Commerce.*—There is no existing commerce at Playa del Rey Inlet and Lagoon. Future commerce at the proposed harbor would consist of recreational small craft, excursion boats, and commercial sport-fishing boats. Representatives of the city of Los Angeles and of Los Angeles County state that in their opinion the proposed small-craft harbor should be used only by recreational craft and that provision should be made for commercial fishing interests at other ports. No commercial fish canneries would be permitted in the harbor area, and no facilities would be provided for the unloading of fresh fish for transshipment by truck to canneries outside the area.

37. The population of 2,308,000 in the tributary area of Playa del Rey gives an indication that about 6,500 boats would be available for berthing in the harbor. This number is based on the average number of craft in California for each 1,000 population.

38. Inasmuch as the area tributary to Playa del Rey contains a high percentage of persons most able to own small craft, it is expected that the number of 6,500 boats would be considerably exceeded. The records of the Los Angeles County assessor show that there are 2,300 small craft now owned by residents of the immediate tributary area. It is conservatively estimated that within 1 year after completion of the project, 1,000 boats would be transferred from other harbors to Playa del Rey Harbor, and that within 5 years after completion of the project, 3,000 new craft would be constructed, sold to individual owners, and based in the proposed harbor. This figure does not include new boats that would be constructed or purchased by residents outside the immediate tributary area (zone 1). The population of the area outside zone 1, but which logically would be tributary to Playa del Rey rather than to one of the other existing or proposed harbors in the area, exceeds 600,000 persons. This would create an additional potential boat reserve of 960 new craft. To be prepared for future requirements, the proposed harbor would have a capacity of 8,000 craft. It is estimated that 35 of the boats would be commercial sport-fishing vessels carrying charter parties or making regularly scheduled runs.

39. Playa del Rey Harbor would be open to all craft as a port of refuge in case of emergency. Furthermore, the harbor would be used by visiting craft from San Diego Bay, Newport Bay Harbor, Los Angeles and Long Beach Harbors, and Redondo Beach Harbor, and as a port of call for small craft making the longer trips to Santa

Barbara, Monterey, and San Francisco, and for northern small craft cruising in southern waters.

40. *Vessel traffic.* There is no vessel traffic at Playa del Rey other than an occasional rowboat on the Venice canals. Numerous boats cruise in the open sea adjacent to the shore.

#### DIFFICULTIES ATTENDING NAVIGATION

41. In the vicinity of Playa del Rey, westerly and southwesterly winds prevail most of the year, but there are intermissions of calm during autumn and winter, as indicated by the wind rose on map, enclosure 1. The most severe storms are produced by the occasional southerly winds which occur in winter. The prevailing westerly winds seldom become more than moderate gales.

42. There are no adequately protected areas for small craft in Santa Monica Bay. Partial protection is provided at Redondo Beach, 8 miles to the south, and at Santa Monica, 3 miles to the north, of the site of the proposed harbor at Playa del Rey. At Redondo Beach the harbor formed by the breakwater consists of only about 20 acres of semiprotected area. The breakwater provides protection from westerly storm waves, but craft in its lee are exposed to the southerly storms. During these storms about 10 craft are washed ashore at Redondo Beach each year.

43. At Santa Monica Harbor an area of about 46 acres is partially protected by an offshore breakwater 2,000 feet in length. The breakwater was constructed by the city of Santa Monica in 1934 and has so deteriorated that storm waves break over the structure and create rough water within the harbor area. An average of 50 boats a year break loose from their moorings and are washed ashore. About 20 percent of these boats are a complete loss, as the surf breaks up the beached craft. It is improbable that the breakwater structure will be restored and maintained, mainly because the inadequate facilities and the restricted-water area cannot be remedied owing to site limitations.

44. All small-craft navigation in Santa Monica Bay is endangered by the lack of an adequate harbor of refuge.

#### SPECIAL SUBJECTS

45. *Shoreline changes.*—Pursuant to section 5 of the River and Harbor Act approved August 30, 1935 (Public Law 409, 79th Cong.), a detailed investigation was made with a view to determining probable effect of the proposed improvement upon the adjacent shoreline. A full report of the investigation is contained in enclosures 19<sup>1</sup> and 20.<sup>1</sup> Specific studies undertaken included a geological investigation to determine general trends in physiographic development of the coastal area, a determination of wave characteristics, surveys to trace the movement of beach material, investigation of the effect of existing structures, analysis of slopes of artificial fills made on southern California beaches, and an estimation of littoral characteristics in the Santa Monica Bay area.

46. Conclusions reached in the investigation of shore effects are quoted as follows:

<sup>1</sup> Not printed.

(a)  
break  
const  
(b)  
toral  
shore  
Beach  
Harb  
opme  
(c)  
jettie  
(d)  
would  
and t  
Los A  
shore  
about  
(e)  
Moni  
period  
naval  
transf  
(f)  
their  
propo  
areas  
determ  
been e  
47.  
harbor  
and d  
Street  
Altern  
Shore  
maps.  
from e  
48.  
not in  
that e  
United  
of an  
and co  
49.  
elimin  
Fish a  
objecti  
represent  
birds c  
operat  
refuge  
contro  
for the  
are kil  
other

(a) The shores of Santa Monica Bay downcoast from Santa Monica breakwater have been deprived of normal littoral nourishment since construction of Santa Monica breakwater in 1933.

(b) Proposed jetties at Playa del Rey would act as a complete littoral barrier for a considerable period of time and would benefit the shore to the north by preventing further littoral loss from that area. Beach fill made in this area with material dredged from Playa del Rey Harbor would assist in completion of the comprehensive shore development planned by the city of Los Angeles.

(c) Between Ballona Creek jetties and proposed Playa del Rey jetties, the shore would stabilize after minor realinement.

(d) Downcoast from Ballona Creek, establishment of a feeder beach would be required to provide nourishment for shores to the south, and to prevent depletion of the fill recently completed by the city of Los Angeles. Deposit of 3,200,000 cubic yards along 5,000 feet of shore would be expected to provide adequate supply for a period of about 20 years.

(e) Future maintenance of Santa Monica Bay shores between Santa Monica breakwater and Playa del Rey may be accomplished by periodic replenishment of a suitably located feeder beach, or by removal of the breakwater and reestablishment of normal littoral transport at Santa Monica.

(f) Shores downcoast from Ballona Creek can be maintained in their advanced position by mechanical bypassing of sand past the proposed harbor entrance or by periodic deposit of sand from inland areas on the feeder beach. The most economic method can best be determined after the plan for maintenance of upcoast beaches has been established.

47. *Field surveys.*—Hydrographic and topographic surveys of the harbor and adjacent shore areas were made in March and April 1945, and during 1948. The surveys included the area from Washington Street to the Playa del Rey Hills and extended from Highway U. S. 101 Alternate (Lincoln Blvd.) seaward to about the 40-foot-depth contour. Shore topography was traced from aerial photographs and existing maps. The character of materials to be dredged was determined from auger borings.

48. *Coordination with other improvements.*—The improvement would not involve flood control, water power, water supply, or other subjects that could be coordinated with the improvement to compensate the United States for expenditures made. The project is an integral part of an overall plan of improvement of the beach areas by municipal and county agencies.

49. *Effect on wildlife.*—Construction of the proposed harbor would eliminate existing marshlands of some wildlife value. However, the Fish and Wildlife Service by letter dated April 26, 1946, state that no objection will be interposed to the construction of the project. Local representatives of the Fish and Wildlife Service state that few game birds occupy the area because of oil pollution which results from the operation of the oil field. Local interests propose to construct a bird refuge about 800 feet wide and 2,500 feet long adjacent to the flood-control channel as a part of the overall park development to provide for the shore birds nesting in the area. Principal among these birds are killdeer, sandpiper, stilt, and tern. In addition there are many other species of birdlife which are not dependent on the area. To

provide for the continuation of this existing birdlife, local interests should construct the bird refuge simultaneously with the construction of the harbor.

50. *Saline contamination.*—An investigation was made concerning the effects of the proposed harbor on saline contamination of underground water. This investigation indicated that (1) sea water has already contaminated the ground water within most of the area that would be occupied by the harbor; (2) further landward progress of this contamination depends primarily on the rate of withdrawal of ground water in the vicinity of the harbor site and on the steepness of the landward gradient produced by this withdrawal; and (3) introduction of sea water by constructing the harbor would not modify existing ground-water conditions.

51. *Harbor lines.*—Harbor lines have not been established in Santa Monica Bay. The plan considered would not adversely affect the future establishment of harbor lines.

52. *Aids to navigation.*—If the proposed harbor is constructed, the district Coast Guard officer, 11th Coast Guard District, recommends the installation of coded lights on the seaward ends of the proposed harbor jetties, the installation of a fog signal on the upcoast jetty, and installation of additional lights at the beginning of the curve on each jetty. Three light buoys would be required to mark the turns in the basin channel. The district Coast Guard officer estimates the total cost of aids to navigation at \$25,000.

#### PLANS OF IMPROVEMENT

53. *Plans considered.*—In determining the best plan of improvement the district engineer gave consideration to the desires of local interests as stated at the public hearings, to the more recent desires of local interests as developed by conferences, to modifications suggested by experienced small-craft operators, and to the requirements of navigation interests in general.

54. The plan originally proposed by local interests included a symmetrically arranged U-shaped harbor which had two entrances and capacity for about 5,200 craft. Local interests now believe that a harbor of that capacity would be inadequate to meet all the demands for anchorage, berthing, and maneuvering, and for adequate servicing and concessionary facilities; therefore, a modified elliptical area approximately 6,500 feet by 6,300 feet was proposed for consideration. The elliptical harbor would have capacity for about 8,000 craft. The two entrances were decided to be undesirable, as a stretch of beach about 2,100 feet long would be rendered inaccessible except by boat. This isolated island would not conform to the general plan of improvement approved by the Los Angeles City Council.

55. Combining the entrance channel with the Ballona Creek flood-control outlet would prove unsatisfactory, from the standpoint of navigation and maintenance of harbor depths. To eliminate both the isolated beach and entrance through the flood-control outlet, local interests proposed a curving entrance adjacent to the flood-control outlet. However, experienced small-craft operators state that a curved entrance is difficult to navigate, especially in foggy or heavy weather. Accordingly, consideration was given to straightening the proposed entrance. This would result in a long and rather wide en-

trance that  
efficient us  
trance, bo  
would be 1  
Furthermo  
southerly  
wave cond

56. The  
single, sho  
undesirable

57. The  
modified se  
the central  
craft in the

58. All f  
were discu  
provement  
by all respo  
Los Angele  
engineer, th  
regional pla

59. *Reco:*  
engineer pr  
enclosure 1

(a) An e  
dredged to

(b) Two

(c) A 30  
flood-contri

(d) A mi  
two souther  
of 20 feet b

(e) A cer  
D, E, F, G  
mean lower

(f) Dispo  
ing to abor  
piers betwe  
harbor, and

as permane  
and to prov  
control cha

(g) Verti  
revetment  
basin.

(h) Slips  
ing small cr

(i) Road  
tions, lands  
modern reci

o0. Unde  
abutments  
for berthing

Not printed

trance that would require a large area which would not make the most efficient use of the available space. Also, with a southerly side entrance, boats based in the northerly portion of the proposed harbor would be required to travel an excessive distance to reach the ocean. Furthermore, any entrance at the southerly side would subject the southerly shore of the proposed harbor to unfavorable and destructive wave conditions during storms.

56. The plan considered by the district engineer, which comprises a single, short, central entrance, would adequately overcome all the undesirable features of the side entrance.

57. The plans for side basins bordering the main central basin were modified so that the long axes of most side basins would be radial to the central basin. This modification would facilitate berthing small craft in the side basins.

58. All factors affecting the design of the harbor at Playa del Rey were discussed with interested local agencies, and the plan of improvement considered by the district engineer is the plan now desired by all responsible local interests. The plan has been approved by the Los Angeles City Council, the city planning commission, the city engineer, the Los Angeles County Board of Supervisors, the county regional planning commission, and the county engineer.

59. *Recommended plan.*—The plan recommended by the district engineer provides for the following principal features, as shown on enclosure 1.

(a) An entrance channel about 1,925 feet long and 600 feet wide, dredged to a depth of 20 feet below mean lower low water.

(b) Two random-stone jetties, each 2,300 feet in length.

(c) A 300-foot extension to the upcoast jetty at Ballona Creek flood-control channel outlet.

(d) A main interior channel 600 feet wide and 5,600 feet long, and two southerly side basins (designated C and K), all dredged to a depth of 20 feet below mean lower low water.

(e) A central basin and 10 additional side basins (designated A, B, D, E, F, G, H, I, J, and L), all dredged to a depth of 10 feet below mean lower low water.

(f) Disposal of material dredged from the proposed harbor, amounting to about 20,360,000 cubic yards, to construct solid-fill mole-type piers between the side basins, to reclaim lowlands adjacent to the harbor, and to provide about 160 acres of land by widening the beach as permanent beach improvement upcoast from the harbor entrance and to provide a separate feeder beach south of Ballona Creek flood-control channel for nourishment of the downcoast shore.

(g) Vertical bulkhead around side basin K, and random-stone revetment on the slopes of the remaining side basins and the central basin.

(h) Slips and facilities for berthing, servicing, supplying, and repairing small craft.

(i) Roads, parking areas, administration buildings, comfort stations, landscaping, clubhouses, and all other facilities required for a modern recreational small-craft development.

60. Under the general plan, 11 mole-type piers and the entrance abutments would divide the bay into 12 side basins with a capacity for berthing 8,000 small craft at slips. See exhibit 1, enclosure 16,<sup>1</sup>

<sup>1</sup> Not printed.

for a diagrammatic sketch of the arrangement of slips used to determine the capacity of the harbor. Ultimate development of a typical mole arrangement proposed by local interests is shown on enclosure 4,<sup>1</sup> "General plan of harbor," by the Los Angeles City Planning Commission. The pierheads would be reserved for concessions, such as gasoline and oil stations, small stores, cafes, and boat clubs. The pier between basins marked D and E on the general plan, enclosure 1, would be used for harbor administration. The pier on each side of basin K would be reserved for boat-repairing facilities and other commercial purposes. The pier between basins A and B would be used by marine-outing clubs. Parking areas are located wherever space permits. The harbor area is considered as that section encircled by the perimeter road. Justification of all features of design and all items included in the recommended project are contained in enclosure 16.<sup>1</sup>

FIRST COST AND ANNUAL CHARGES

61. *Estimate of first cost.*—The total first cost of the improvements, based on 1948 prices, is estimated at \$25,603,000, of which \$16,505,000 would be borne by local interests and \$9,098,000 by the United States. Details of the estimate are given in enclosure 16<sup>1</sup> and are summarized in the following table:

*Estimate of first cost, Playa del Rey, Calif.*

Federal costs:

Corps of Engineers:

|                                                                         |             |
|-------------------------------------------------------------------------|-------------|
| Dredging entrance channel and interior basins and filling lowlands..... | \$5,090,000 |
| Stone jetties, entrance channel.....                                    | 2,168,680   |
| Subtotal.....                                                           | 7,258,680   |
| Engineering and contingencies, 25± percent.....                         | 1,814,320   |

Total..... 9,073,000

U. S. Coast Guard: Aids to navigation..... 25,000

Total Federal 1st cost..... 9,098,000

Non-Federal costs:

|                                                                                                              |           |
|--------------------------------------------------------------------------------------------------------------|-----------|
| Stone jetty extension, Ballona Creek.....                                                                    | 126,450   |
| Stone revetment, interior basins.....                                                                        | 388,500   |
| Vertical bulkhead, boat repair basin.....                                                                    | 1,314,400 |
| Landscaping mole-type piers.....                                                                             | 25,670    |
| Administration building.....                                                                                 | 150,000   |
| Floats, slips, light and water facilities.....                                                               | 860,000   |
| Paving (parking areas).....                                                                                  | 736,050   |
| Paving (roads).....                                                                                          | 911,650   |
| Relocation of Venice sewer and constructing mains and laterals.....                                          | 2,150,000 |
| Public utilities, relocation and construction of water and electric lines, and removal of oil pipelines..... | 1,200,000 |
| Subtotal.....                                                                                                | 7,862,720 |

<sup>1</sup> Not printed.

Non-F  
Eh

La  
Di

Cc  
Ac

Le

62.  
it was  
salvag  
ligible  
50 yea  
\$3,352  
immed  
ments,  
C in ei  
to be t  
asmuel  
master  
Angele  
estima  
from sl  
as sho  
50 per  
4,000 t

Under 20 f  
20 feet to 3  
35 feet to 5  
51 feet to 11  
Over 100 ft

Tota  
Estimated  
Esti

<sup>1</sup> Not pri

*Estimate of first cost, Playa del Rey, Calif—Continued*

|                                                                   |             |             |
|-------------------------------------------------------------------|-------------|-------------|
| Non-Federal costs—Continued                                       |             |             |
| Engineering and contingencies, 25± percent.....                   |             | \$1,965,280 |
| Total non-Federal, except land and rights-of-way.....             |             | 9,828,000   |
| Land and improvements.....                                        | \$4,410,500 |             |
| Drilling offset wells and capping existing wells....              | 1,422,000   |             |
| Subtotal.....                                                     | 5,832,500   |             |
| Contingencies, 10± percent.....                                   | 583,300     |             |
| Acquisition cost, about 10 percent of land and rights-of-way..... | 441,200     |             |
| Subtotal.....                                                     | 6,857,000   |             |
| Less immediate salvage value of improvements..                    | -180,000    | 6,677,000   |
| Total non-Federal cost.....                                       |             | 16,505,000  |
| Total Federal cost.....                                           |             | 9,098,000   |
| Total first cost of project.....                                  |             | 25,603,000  |

62. *Estimate of annual charges.*—In computing the interest charges, it was assumed that the construction would require 3 years. The salvage value of all improvements is assumed to be nominal or negligible at the expiration of the useful life of the project, estimated at 50 years. However, the net salvage value of the land is estimated at \$3,352,000. This amount is equal to the total estimated value, immediately after filling and prior to construction of any improvements, of filled lands within the taking area described as areas B and C in enclosure 17.<sup>1</sup> The salvage value of the 160 acres of new beach to be constructed is not assumed to be creditable to this project inasmuch as nourishment of this beach would be provided for under the master plan for beach development by the city and county of Los Angeles, Calif. In computing the non-Federal carrying charges the estimated returns from improvements represent only the net return from slip rentals after deduction of operation and maintenance costs, as shown in the following table. This net return is based on using 50 percent of the estimated total annual return from slip rental for 4,000 boats, as follows:

| Boat size                                          | Percent | Number of boats | Estimated annual slip charge | Total    |
|----------------------------------------------------|---------|-----------------|------------------------------|----------|
| Under 20 feet.....                                 | 43.1    | 1,724           | \$56.00                      | \$96,544 |
| 20 feet to 35 feet.....                            | 41.6    | 1,664           | 102.00                       | 169,730  |
| 35 feet to 50 feet.....                            | 11.6    | 464             | 148.50                       | 67,976   |
| 51 feet to 100 feet.....                           | 2.9     | 116             | 253.00                       | 29,350   |
| Over 100 feet.....                                 | .8      | 32              | 550.00                       | 17,600   |
| Total.....                                         | 100.0   | 4,000           |                              | 381,200  |
| Estimated operation and maintenance costs.....     |         |                 |                              | 190,600  |
| Estimated direct net returns from improvement..... |         |                 |                              | 190,600  |

<sup>1</sup> Not printed.

63. The estimated annual charges for the improvements are given in the following table:

*Estimated annual charges for Playa del Rey Harbor, Calif.*

|                                                                                                |       |                  |
|------------------------------------------------------------------------------------------------|-------|------------------|
| (a) Federal investment:                                                                        |       |                  |
| (1) Corps of Engineers.....                                                                    | ..... | \$9,073,000      |
| (2) U. S. Coast Guard.....                                                                     | ..... | 25,000           |
| (3) Total Federal 1st cost (see estimate of 1st cost).....                                     | ..... | 9,098,000        |
| (4) Interest during 1/2 of construction period: 3 percent of item (a) (3) for 1.5 years.....   | ..... | 409,410          |
| (5) Total Federal investment to be justified by benefits and subject to amortization.....      | ..... | 9,507,410        |
| (b) Federal annual charges:                                                                    |       |                  |
| (1) Interest at 3 percent of item (a) (5).....                                                 | ..... | 285,220          |
| (2) Amortization for 50 years at 3 percent: 0.00887 times item (a) (5).....                    | ..... | 84,330           |
| (3) Maintenance.....                                                                           | ..... | 26,000           |
| (4) Total Federal annual charges.....                                                          | ..... | 395,550          |
| (c) Non-Federal investment:                                                                    |       |                  |
| (1) Funds to be contributed or cost of improvements to be undertaken by local interests.....   | ..... | 9,828,000        |
| (2) Value of rights-of-way to be furnished.....                                                | ..... | 6,677,000        |
| (3) Total non-Federal 1st cost (see estimate of 1st cost).....                                 | ..... | 16,505,000       |
| (4) Interest during 1/2 of construction period: 3.5 percent of item (c) (3) for 1.5 years..... | ..... | 866,510          |
| (5) Gross non-Federal investment to be justified by benefits.....                              | ..... | 17,371,510       |
| (6) Less net salvage value of land.....                                                        | ..... | -3,352,000       |
| (7) Net non-Federal investment subject to amortization.....                                    | ..... | 14,019,510       |
| (d) Non-Federal annual charges:                                                                |       |                  |
| (1) Interest at 3.5 percent of item (c) (5).....                                               | ..... | 608,000          |
| (2) Amortization for 50 years at 3.5 percent: 0.00763 times item (c) (7).....                  | ..... | 106,970          |
| (3) Maintenance.....                                                                           | ..... | ( <sup>2</sup> ) |
| (4) Gross non-Federal annual charges.....                                                      | ..... | 714,970          |
| (5) Less estimated direct net returns from slip rentals.....                                   | ..... | -190,600         |
| (6) Net non-Federal annual charges.....                                                        | ..... | 524,370          |
| (e) Total estimated annual charges.....                                                        | ..... | 919,920          |

*Summary of 1st costs and annual charges*

| Item             | First cost  | Interest  | Investment  | Annual charges | Annual maintenance |
|------------------|-------------|-----------|-------------|----------------|--------------------|
| Federal.....     | \$9,098,000 | \$499,410 | \$9,507,410 | \$395,550      | \$26,000           |
| Non-Federal..... | 16,505,000  | 866,510   | 17,371,510  | 524,370        | ( <sup>2</sup> )   |
| Total.....       | 25,603,000  | 1,275,920 | 26,878,920  | 919,920        | \$26,000           |

<sup>1</sup> Includes \$1,000 maintenance by U. S. Coast Guard.  
<sup>2</sup> Estimated \$190,600 income from slip rentals to be used for operation and non-Federal maintenance.

64. Playa 20,360 area. lands i develop center. immed. land b. marshl. in valu. lands p. Rey, or the har of the a value tl propose 65. T dredging additional as listed

Area A: :  
 Area B: :  
 Area C: :  
 New beac

To  
 The ave: of filling benefits 66. M consists of l. as a res: Creek M on mosq be spent by the f provide : tary ben by the e

67. Be the prop type and records ( small-cra the antic local int available proposed small cri would ac

<sup>3</sup> Not pri



## ESTIMATES OF AVERAGE ANNUAL BENEFITS

64. *Increased value of filled land.*—In constructing a harbor at Playa del Rey, the Federal Government would dredge approximately 20,360,000 cubic yards of material to provide about 717 acres of water area. The dredged material would be deposited to fill adjacent lowlands and to create additional beach land. Local interests plan to develop the adjacent area as an all-year beach resort and recreation center. The artificial widening of the beach would result in an immediate increase in value of the filled area. The low, undeveloped land between Ballona Creek and the Playa del Rey Hills and the marshland in the harbor area would be reclaimed and would increase in value. In estimating the benefits that would result from filling lowlands pursuant to construction of the proposed harbor at Playa del Rey, only those areas that would be filled with material dredged from the harbor have been considered. The estimated increase in value of the areas reclaimed or filled in no way reflects any enhancement in value that would accrue to the land by virtue of its proximity to the proposed harbor.

65. The water area for the proposed harbor would be created by dredging about 717 acres of marsh and low land. An estimated additional 844 acres of land would be filled with the dredged material as listed below:

|                                     | <i>Acres</i> |
|-------------------------------------|--------------|
| Area A: South of Ballona Creek..... | 358          |
| Area B: Mole-type piers.....        | 203          |
| Area C: West of Lincoln Blvd.....   | 123          |
| New beach.....                      | 160          |
| <b>Total.....</b>                   | <b>844</b>   |

The average annual benefits from the increased value of land by reason of filling only are estimated at \$215,000. Further details concerning benefits from increased land value are given in enclosure 17.<sup>1</sup>

66. *Mosquito control savings.*—The site of the proposed harbor consists of low, marshy land with inadequate provisions for drainage and, as a result, a large area of water is almost stagnant. The Ballona Creek Mosquito Abatement District spends about \$21,000 annually on mosquito control. Approximately 75 percent of these funds would be spent in the area to be improved. The elimination of this problem by the filling of marsh areas or by improvement of drainage would provide an annual benefit of \$16,000. In addition to tangible monetary benefits, conditions affecting public health would be improved by the elimination of mosquito breeding areas. (See enclosure 17.<sup>1</sup>)

67. *Benefits from navigation.*—The benefits that would accrue to the proposed harbor project from navigation are dependent on the type and number of craft that would use the facility. Based on the records of similar developments in California and on reports from small-craft manufacturers on their backlog of orders for new craft, the anticipated number of boats would exceed 6,500. According to local interests and boat manufacturers, if accommodations were available, 10,000 new craft would be built in the next few years. The proposed harbor at Playa del Rey would have a capacity of 8,000 small craft. However, in computing the recreational benefit that would accrue from navigation, the number of new craft of average

<sup>1</sup> Not printed.

size that would be based in the harbor has been estimated to be only 3,000. The proposed Playa del Rey Harbor would be open to all craft as a port of refuge and as a port of call by many small craft. Additional tangible benefits that would accrue from the navigation features of the proposed project are automobile travel savings, boat maintenance savings, prevention of boat damage, and increased fish catch. Some of the intangible navigation benefits which would accrue from the project are, increase in the recreational activities of the community, creation of additional business opportunities, increase in safety of navigation, and increase in opportunity for boatowners to operate their small craft.

68. *Recreational harbor benefit.*—The monetary benefit from the recreational use of a small-craft harbor is estimated to be the annual income from a capital investment equivalent to the average value of the small-craft fleet at that harbor. On the basis of an average value of \$6,000 each, the monetary benefit that would result from the estimated minimum fleet of 3,000 new small craft that would occupy the proposed Playa del Rey Harbor, is estimated at \$900,000. (See enclosure 17.<sup>1</sup>)

69. *Automobile travel savings.*—Most boatowners living in the area tributary to Playa del Rey (zone 1) are unable to anchor their boats at Santa Monica Harbor and must keep them at Los Angeles Harbor, Long Beach Harbor, Newport Bay Harbor, or at some more distant port because of the lack of proper harbor facilities in Santa Monica Bay. The actual monetary saving of automobile operating costs by the estimated 1,000 boatowners who would transfer their boats from one of the more distant harbors to Playa del Rey Harbor is estimated at \$35,000. (See enclosure 17.<sup>1</sup>)

70. *Boat maintenance savings.*—The boatowners living in the area tributary to Playa del Rey whose craft are moored in the commercial harbors of Los Angeles or Long Beach would benefit by having a recreational harbor. Provision of such a harbor would result in a saving through decreased maintenance costs to small craft because of their removal from sources of contamination as exists in a commercial harbor. The annual savings in maintenance cost by the estimated 400 boatowners who would transfer their boats from Los Angeles and Long Beach Harbors to Playa del Rey Harbor is estimated at \$8,000. (See enclosure 17.<sup>1</sup>)

71. *Prevention of boat damage.*—Small craft in Santa Monica Bay are exposed to the sudden and sometimes moderately severe storms that occur annually during the period December to March, inclusive. Records of past storms indicate that about 60 small craft are beached annually by storms because of the lack of a safe anchorage area. The proposed Playa del Rey and Redondo Beach Harbors would replace existing inadequate facilities and offer refuge to all small craft operating in Santa Monica Bay. The total annual benefit from the prevention of this damage to small craft that would be creditable to the proposed Playa del Rey Harbor is estimated at \$75,000. (See enclosure 17.<sup>1</sup>)

<sup>1</sup> Not printed.

7  
nat  
nati  
boa  
be  
spor  
Rey  
boat  
wou  
The  
fishe  
from  
73  
of m  
ment  
safet  
prov  
age  
incre  
numl  
and s  
74.  
Rey  
ing p  
wou  
craft.  
come,  
and  
benefi  
the p  
be du  
75.  
crease  
the V  
Highw  
consti  
local i  
on Sai  
would  
beach  
afford  
benefit  
76.  
benefit  
in the  
enclos

<sup>1</sup> Not printed.

72. *Increased fish catch.*—Fish caught by sport fishermen add to the national wealth to the extent that this fish catch finds its way into the national food supply. From the records of operators of sport-fishing boats, it is estimated that an additional 2,800,000 pounds of fish would be caught each year because of the estimated increased number of sport-fishing boats that would operate from the proposed Playa del Rey Harbor. In addition to trips made by patrons of sport-fishing boats, the estimated increased number of individual boat owners would take an additional fish catch for which no benefit is claimed. The monetary average annual benefit from fish caught by sport fishermen is estimated at \$280,000. For additional details of benefits from fish catch. (See enclosure 17.<sup>1</sup>)

73. *Intangible benefits.*—Intangible benefits (those not susceptible of monetary evaluation) that would accrue under the plan of improvement considered are large. Benefits would result from increased safety of small-craft navigation in the Santa Monica Bay area by providing a port of refuge for transient craft and a safe port for anchorage of home craft. The pleasure of small-craft operation would be increased by the provision of an adequate facility close to the greatest number of small-craft owners in the Los Angeles metropolitan area and separated from the activities of a large commercial and naval port.

74. Construction of the navigation facility proposed at Playa del Rey Harbor would increase the use of adjacent waters and neighboring ports by small craft because of an additional place to visit, which would increase the pleasure derived from operation of recreational craft. This, in turn, would create new business, additional tax income, and new opportunities for industry in the manufacture, repair, and servicing of additional craft in established harbors. These benefits cannot be evaluated because of the difficulty of determining the proportion of increased use of the established harbors that would be due to the construction of the new facility.

75. Large intangible benefits would also accrue by reason of increased land values in areas adjacent to the proposed harbor, primarily the Venice area and the partially developed area located between Highway U. S. 101 Alternate and Culver City. The proposed harbor constitutes one unit of a large resort and recreation area planned by local interests that would extend from El Segundo to Topanga Canyon on Santa Monica Bay, and a large part of the increased land values would be creditable to that project. The creation of an all-year beach playground would attract visitors from all parts of the country, afford new opportunity for travel, and create an additional economic benefit to the beach communities.

76. *Summary of tangible benefits.*—The average annual tangible benefits that would accrue under the plan considered are summarized in the following table. A detailed analysis of benefits is given in enclosure 17.<sup>1</sup>

<sup>1</sup>Not printed.

Estimated average annual tangible benefits from improvements considered, Playa del Rey, Calif.

| Type of benefit                     | General (Federal) | Local (non-Federal) | Total     |
|-------------------------------------|-------------------|---------------------|-----------|
| Other than navigation:              |                   |                     |           |
| Increased value of filled land..... | 0                 | \$215,000           | \$215,000 |
| Mosquito control savings.....       | 0                 | 16,000              | 16,000    |
| Subtotal.....                       | 0                 | 231,000             | 231,000   |
| Navigation:                         |                   |                     |           |
| Recreational harbor benefit.....    | \$450,000         | 450,000             | 900,000   |
| Automobile travel savings.....      | 0                 | 35,000              | 35,000    |
| Boat maintenance savings.....       | 0                 | 8,000               | 8,000     |
| Prevention of boat damage.....      | 75,000            | 0                   | 75,000    |
| Increased fish catch.....           | 280,000           | 0                   | 280,000   |
| Subtotal.....                       | 805,000           | 493,000             | 1,298,000 |
| Total.....                          | 805,000           | 724,000             | 1,529,000 |

#### COMPARISON OF BENEFITS AND COSTS

77. The total cost of the proposed improvement is estimated at \$25,603,000. The total annual carrying charges would be \$919,920. The annual benefits would be \$1,529,000. The benefit-cost ratio of the proposed harbor project would be 1.7 to 1. In addition to the tangible benefits there would be considerable intangible benefits which, while not susceptible of monetary evaluation, are worthy of consideration.

#### PROPOSED LOCAL COOPERATION

78. At the public hearings local interests expressed a willingness to cooperate in the cost of the project. The formation of a recreation and harbor district was proposed for the purpose of meeting financial requirements through sale of bonds. One object of the report being prepared by the firm of consulting engineers employed by local interests is to determine the best methods of financing the beach development and harbor projects. The city of Los Angeles and the county of Los Angeles, by resolutions, furnished as enclosure 18, agreed to assume the following obligations: (1) Provide all rights-of-way for construction and maintenance of improvements; (2) hold and save the United States free from all claims for damages resulting from the construction or operation of the improvement; (3) assume the cost of alteration, relocation, or rebuilding of highways and highway bridges, or arrange for the alteration, relocation, or rebuilding of these highways and highway bridges; (4) assume the cost of relocation or reconstruction of utilities or drainage structures; (5) contribute in cash or equivalent work, the cost of constructing a vertical bulkhead, stone revetments in all basins, and extension of the north jetty at Ballona Creek; (6) provide without cost to the United States all necessary slips and facilities for repair, service, maintenance, and supply of small craft; (7) secure and hold for the public interest, lands bordering the proposed development to a width sufficient for proper functioning of the harbor; (8) furnish assurances satisfactory to the Secretary of the Army that the area will be improved in accordance with plans and time schedules to be approved by the Secretary of

<sup>1</sup> Not printed.

the Ar  
aids to  
and in  
that al

79. interest  
(2) the  
general  
of the  
would  
tion in  
aids to  
an estir  
ceding  
provide  
graph,  
first cos  
"Estima  
entrance  
and into  
annual  
United S  
be paid

80. L  
of adequ  
Bay area  
boating  
to permi  
(4) requ  
Bay, an  
small-cra  
facility  
81. T)  
made by  
ever, in  
was give  
Redondc  
Playa de  
is inadeq  
officials  
maintain  
at Los A  
that por  
Rey tha  
sidered i  
from, a r  
82. Re  
tinued b  
operator

the Army; and (9) maintain and operate the entire project except aids to navigation, entrance jetties, project depths in the entrance and interior channels and the central basin, with the understanding that all facilities shall be open to all on equal terms.

ALLOCATION OF COSTS

79. The distribution of costs between Federal and non-Federal interests is based on (1) the distribution of local and general benefits, (2) the ability of local interests to pay, and (3) consideration of the general nature of the work items. Accordingly, of the total first cost of the proposed project estimated at \$25,603,000, the United States would provide those items of construction that would benefit navigation in general, comprising the construction of entrance jetties and aids to navigation, and the dredging of channels and basins, all at an estimated Federal first cost of \$9,098,000, as itemized in the preceding paragraph, "Estimates of first cost." Local interests would provide the items of local cooperation named in the preceding paragraph, "Proposed local cooperation," all at an estimated non-Federal first cost of \$16,505,000, and as itemized in the preceding paragraph, "Estimates of first cost." The United States would maintain the entrance jetties, aids to navigation, and harbor depths in the entrance and interior channels and in the central basin, all at an estimated annual cost of \$25,000 for the Corps of Engineers, and \$1,000 for the United States Coast Guard. Non-Federal annual maintenance would be paid from operating revenues.

DISCUSSION

80. Local interests base justification for the project on (1) the lack of adequate facilities for small-craft navigation in the Santa Monica Bay area, (2) the desirability of separating small craft and recreational boating from commercial and naval waters, (3) the need for facilities to permit growth of recreational and commercial small-craft operation, (4) requirements for safety of small-craft operation in Santa Monica Bay, and (5) the favorable economic effect that development of small-craft operation and the provision of an adequate small-craft facility would have on the community.

81. The district engineer concurs in general with the statements made by local interests concerning justification of the project. However, in determining the extent of the tributary area, consideration was given to the proposed improvement of the small-craft harbor at Redondo Beach, 8.2 miles downcoast from the proposed harbor at Playa del Rey. The protection afforded by Santa Monica breakwater is inadequate and gives the boatowner a false sense of security. City officials of Santa Monica have stated that the structure will not be maintained. Consideration also was given to the existing harbors at Los Angeles, Long Beach, and Newport Bay. Accordingly, only that portion of the general tributary area that is closer to Playa del Rey than to any other existing or proposed harbor has been considered in determining the need for, or the benefits that would result from, a navigation project at Playa del Rey.

82. Recovery of petroleum from the Venice oilfield could be continued by relocating existing oil wells so as not to interfere with operation of the proposed harbor.

83. Annual tangible benefits from the navigation improvement would be \$215,000 from increased value of filled land, \$16,000 from cost of mosquito control savings, \$900,000 from recreational harbor benefits, \$35,000 from automobile travel savings, \$8,000 from boat maintenance savings, \$75,000 from prevention of boat damage, and \$280,000 from increased fish catch, a total of \$1,529,000 a year.

84. In addition to the tangible benefits, the proposed navigation project would result in large intangible benefits which have considerable weight in justification of the project. The intangible benefits would include the noncalculable benefits from (1) the increased safety of navigation, (2) the recreational value of an all-year small-craft harbor near the largest concentration of boatowners in the Los Angeles metropolitan area, (3) the promotion of general welfare by the increase in opportunities for employment, and (4) increase in land values in the vicinity of the proposed harbor area that would be partially attributable to the proposed navigation improvement.

85. The estimated total first cost of the proposed navigation project is \$25,603,000. Of this amount, \$16,505,000 would be borne by local interests. The total annual charges would be \$919,920 and the total annual benefits \$1,529,000. The benefit-cost ratio is 1.7 to 1.

86. The project considered by the district engineer meets the present desires of local interests. The project has the approval of the city of Los Angeles and Los Angeles County. The harbor project forms one unit of the master plan of the county of Los Angeles for shoreline development. The project is also one unit of the plan of the city of Los Angeles for the development of the shoreline between El Segundo and Topanga Canyon. This plan was approved by the Los Angeles City Council. The overall plan of development proposed by the city of Los Angeles is included as enclosure 11.<sup>1</sup>

87. Departures from the original plans desired by local interests were made by the district engineer to provide better navigation conditions within the proposed harbor and entrance channel, to make more efficient use of the dredged water area, and to reduce the total cost of the proposed improvements.

88. Both the city of Los Angeles and the county of Los Angeles have expressed their desire and willingness to cooperate with the Federal Government by sharing in the cost of the project through fulfilling all items of local cooperation required. Either the city or county of Los Angeles would be able to meet the requirements of local cooperation through direct bond issue or formation of a harbor district. The State of California has adopted a policy of assisting local bodies in meeting items of cooperation for flood control required by the Federal Government, as evidenced by the State Water Resources Act approved July 19, 1945, appropriating \$30 million for that purpose. The State also has a policy of cooperating with local public bodies on a matching basis in the acquisition of beaches. It is reasonable to assume that these policies will be extended to include other Federal projects.

89. An investigation of the small-craft harbors in southern California indicates an urgent need for additional facilities. Newport Bay Harbor is the only first-class small-craft harbor in the southern California

<sup>1</sup> Not printed.

area.  
proje  
auth  
Redo  
inade  
Calif  
area  
numb  
of 3,0  
nishe  
contir  
of sm  
facilit  
const  
90.  
a new  
the ex  
establ  
port fi  
91.  
at Pla  
the ci  
receivi  
shore  
coast  
compl  
would  
littora  
the exi  
stable  
Redon  
Nouris  
erosior  
area ca  
from F  
a view  
nance  
involv  
is put i  
coast f  
lem, th  
a feede  
yards c  
It is e  
provide  
20 year

92. 7  
(a) 7  
Califon  
(b) 7  
5 years

area. An integrated recreational marine park and small-craft harbor project at Mission Bay, San Diego, Calif. (120 miles downcoast), was authorized by act approved July 24, 1946. A review of reports on Redondo Beach Harbor is in progress. These harbors would be inadequate to meet the demand for berthing small craft in southern California. Shipbuilding and ship brokerage firms in the Los Angeles area have a backlog of small-craft orders that would increase the number of small craft in southern California coastal waters at the rate of 3,000 boats a year for the next 2 years, provided berths are furnished for these craft. It is reasonable to assume that this trend would continue. Boatbuilders state they are unable to consummate sales of small craft because berthing space is not available. The limited facilities for small craft in Los Angeles and Long Beach Harbors are constantly subject to encroachment by commercial and naval needs.

90. The history of established harbors shows that construction of a new harbor does not result in the transfer of commercial facilities from the existing ports, but tends to increase the facilities in the older established ports in addition to encouraging establishment of new port facilities in a new harbor.

91. A detailed study of the probable effects of the proposed jetties at Playa del Rey upon the adjacent shoreline revealed that between the cities of Santa Monica and Redondo Beach, the shore is now receiving inadequate natural nourishment for maintenance of stable shore alinement. The predominate direction of littoral drift is downcoast throughout this area. The proposed jetties would act as a complete barrier to littoral drift for a considerable period of time and would benefit the shore upcoast therefrom by preventing further littoral loss. From the proposed Playa del Rey Harbor entrance to the existing upcoast Ballona Creek jetty, the shoreline would become stable after minor realinement. Downcoast from Ballona Creek to Redondo breakwater, no natural littoral supply would be available. Nourishment by mechanical means would be necessary to prevent erosion. The most suitable permanent plan for maintaining this area cannot be determined until a plan for maintaining beaches upcoast from Playa del Rey is established. Studies are now in progress with a view to determining the most suitable permanent plan for maintenance of all of the Santa Monica Bay shores. Many interests are involved and considerable time probably will elapse before such a plan is put into effect. In order to insure nourishment of the shore downcoast from Ballona Creek pending a permanent solution to the problem, the proposed plan of improvement includes the establishment of a feeder beach below Ballona Creek by depositing 3,200,000 cubic yards of material that would be dredged from Playa del Rey Harbor. It is estimated that this quantity of material will be adequate to provide normal maintenance in the downcoast area for approximately 10 years.

#### CONCLUSIONS

92. The district engineer concludes that:

- (a) There is need for additional small-craft facilities in southern California and, in particular, in Santa Monica Bay.
- (b) The improvement would be used to capacity within a period of 10 years after its completion.

(c) The proposed harbor would not seriously impair the recovery of petroleum from the existing Venice oilfield.

(d) The proposed harbor would augment existing harbors, and, while adjustment in small-craft berthing and business would be made, they would not intentionally reduce the use of existing harbors or conflict in any manner with the development of the proposed improvement at Redondo Beach.

(e) The proposed harbor jetties would intercept downcoast littoral drift for a considerable period of time. Other improvements in Santa Monica Bay have altered the natural regimen of littoral forces and a comprehensive plan is required to maintain stability of the shoreline. Provision of a feeder beach in accordance with the proposed plan of improvement would prevent harmful effect upon adjacent shorelines by the proposed jetties pending completion of the comprehensive beach-development plan. The harbor would have a stabilizing effect on the upcoast beaches expected to be improved. The general effect of the proposed harbor on the beaches probably would be beneficial.

(f) An adequate navigation facility can best be provided by constructing entrance jetties and dredging an entrance channel and interior basins.

(g) The plan considered is the best plan for making recreational harbor facilities in Santa Monica Bay available to the largest number of boatowners and potential owners in southern California at the least cost.

(h) The project for small-craft navigation is justified.

(i) In view of the nature of the work and the distribution of benefits, it would be appropriate for the Federal Government to pay the entire cost of constructing aids to navigation, the entrance jetties, and dredging the channels and basins, all at an estimated total Federal first cost of \$9,073,000 for work to be accomplished by the Corps of Engineers.

(j) Local interests should pay the cost of extending the upcoast Ballona Creek jetty; constructing a vertical bulkhead; revetting the side slopes of all the basins; providing all slips and other facilities for operating, berthing, maintaining, repairing, servicing, and supplying small craft; constructing all roads, pavements, and parking facilities; providing all rights-of-way, including the cost of relocating existing oil wells, all at an estimated total first cost of \$16,505,000.

(k) The proposed project would be constructed over a period of 3 years and about \$3,073,000 should be made available initially, \$3 million the second year, and \$3 million the third year.

#### RECOMMENDATIONS

93. The district engineer recommends that a project be adopted to establish a harbor for small-craft navigation at Playa del Rey, Calif., as follows: construct two harbor entrance jetties; extend the upcoast jetty of Ballona Creek flood-control channel; dredge an entrance and interior channel, an interior central basin, and side basins, and deposit the dredged material in areas to be reclaimed for mole-type piers, in lowlands, and along beach frontage; construct stone revetment and vertical bulkheads; construct adequate harbor facilities for operating,

berthing;  
relocate  
existing  
\$25,603  
94. T  
provide  
wide an  
long, an  
and 10  
deposits  
lowlands  
cost of  
annually  
95. T  
project l  
assuranc  
cooperat  
competen  
plish the  
growth, i  
standing  
required  
in the pu  
a width s  
cost of al  
oil wells,  
construct  
of the up  
adequate  
ing, servi  
area for p  
first cost  
schedules  
opment o  
the Secre  
project ex  
in the en  
(4) holdin  
damages  
works.



berthing, maintaining, repairing, servicing, and supplying small craft; relocate and provide utilities and sewage facilities; and relocate existing oil recovery facilities; all at an estimated total first cost of \$25,603,000.

94. The district engineer recommends that the United States provide the 2 harbor entrance jetties; an entrance channel 600 feet wide and 20 feet deep; an interior channel 600 feet wide, 5,600 feet long, and 20 feet deep; 2 side basins 20 feet deep and a central basin and 10 side basins 10 feet deep separated by mole-type piers; and deposition of dredged material in the mole-type piers, on adjacent lowlands, and along beach frontage; all at an estimated Federal first cost of \$9,073,000, exclusive of aids to navigation, and \$25,000 annually for maintenance.

95. The district engineer further recommends that adoption of the project be subject to the conditions that local interests shall give assurances satisfactory to the Secretary of the Army that the required cooperation will be furnished, such cooperation to be performed by a competent and duly authorized public body, financially able to accomplish the obligations so assumed and empowered to regulate the use, growth, and free development of the harbor facilities with the understanding that such facilities shall be open to all on equal terms. The required local cooperation would consist of (1) securing and holding in the public interest lands bordering on the proposed development to a width sufficient for proper functioning of the harbor; assuming the cost of all rights-of-way, including disposal areas, the cost of relocating oil wells, and the cost of relocating and constructing public utilities; constructing stone revetments, a vertical bulkhead, and an extension of the upcoast jetty at Ballona Creek flood-control channel; providing adequate harbor facilities for operating, berthing, maintaining, repairing, servicing, and supplying small craft; and for developing the harbor area for park and recreational purposes, all at an estimated non-Federal first cost of \$16,505,000; (2) preparing definite plans and construction schedules for the construction of small-craft facilities, including development of the mole-type piers, which shall be subject to approval by the Secretary of the Army; (3) maintaining and operating the entire project except aids to navigation, entrance jetties, and project depths in the entrance and interior channels and in the central basin; and (4) holding and saving the United States free from all claims for damages arising from the construction or operation of the project works.

A. T. W. MOORE,

*Colonel, Corps of Engineers, District Engineer.*

[First endorsement]

SOUTH PACIFIC DIVISION,  
CORPS OF ENGINEERS,  
UNITED STATES ARMY,  
OAKLAND ARMY BASE,  
Oakland 14, Calif., August 22, 1949.

Subject: Survey of Harbor at Playa del Rey, Calif. (Basic: August 16, 1948.)

To: Chief of Engineers, Department of the Army, Washington 25, D. C.

1. I concur in the conclusions and recommendations of the district engineer.

2. I have reviewed the economics of the report and consider reasonable the district engineer's estimates of total annual benefits amounting to \$1,529,000 and total annual charges amounting to \$919,920, indicating a favorable benefit-cost ratio of 1.7 to 1.

DWIGHT F. JOHNS,  
Colonel, Corps of Engineers, Division Engineer.

LIST OF ENCLOSURES MADE IN CONNECTION WITH THE REPORT  
OF THE DISTRICT ENGINEER

(Only enclosure 1 printed)

| No. | Title                                                        |
|-----|--------------------------------------------------------------|
| 1.  | General plan of improvement.                                 |
| 2.  | Details and cross sections.                                  |
| 3.  | Borings.                                                     |
| 4.  | General plan by Los Angeles City Planning Commission.        |
| 5.  | Immediate tributary area.                                    |
| 6.  | Tributary area accessible to small-craft harbor development. |
| 7.  | Permit drawing showing proposed beach fill.                  |
| 8.  | Distribution of boatowners.                                  |
| 9.  | Sardine and mackerel fishing localities.                     |
| 10. | Cost tabulation on small-boat navigation.                    |
| 11. | Proposed development plan, Santa Monica Bay shoreline.       |
| 12. | Cost estimate of shoreline development.                      |
| 13. | Photographs.                                                 |
| 14. | Correspondence and data submitted by local interests.        |
| 15. | Letters from boatbuilders.                                   |
| 16. | Bases for design and cost estimates.                         |
| 17. | Benefits from improvements.                                  |
| 18. | Resolutions by local interests.                              |
| 19. | Geology.                                                     |
| 20. | Shoreline effect.                                            |

EXHIBIT 3

[Print](#) | [Close Window](#)

**Subject:** RE: From John Davis Requesting Assistance in regard to Land Deed to the U.S. from California  
**From:** jd@johnanthonydavis.com  
**Date:** Fri, Sep 07, 2012 6:23 pm  
**To:** "Montgomery, Karen" <k15montg@blm.gov>  
**Bcc:** "patricia pherson" <patriciamcpherson1@verizon.net>, "Daniel Cohen" <daniellcohen1956@gmail.com>

Hello,

Thank you for the well thought out and complete response,

John Davis

----- Original Message -----

**Subject:** RE: From John Davis Requesting Assistance in regard to Land Deed to the U.S. from California  
**From:** "Montgomery, Karen" <k15montg@blm.gov>  
**Date:** Fri, September 07, 2012 5:02 pm  
**To:** "jd@johnanthonydavis.com" <jd@johnanthonydavis.com>  
**Cc:** "Staszak, Cynthia" <cstaszak@blm.gov>

Upon our investigation, we were able to locate several references addressing land title records and the Bureau of Land Management's (BLM's) responsibility to maintain them, two of which are listed below:

**By federal statute the BLM is required to make a copy of papers affecting the title of land granted by the United States.**

Whenever any person claiming to be interested in or entitled to land, under any grant or patent from the United States, applies to the Department of the Interior for copies of papers filed and remaining therein, in anywise affecting the title to such land, it shall be the

duty of the Secretary of the Interior to cause such copies to be made out and authenticated, under his hand and the seal of the Bureau of Land Management, for the person so applying. 43 U.S.C. § 18, Acts of January 23, 1823 and July 4, 1836

**The Office of Management and Budget has designated BLM the lead Federal agency with responsibility for Federal Land Ownership Status.**

Federal land ownership status includes the establishment and maintenance of a system for the storage and dissemination of information describing all title, estate or interest of the federal government in a parcel of real and mineral property. The ownership status system is the portrayal of title for all such federal estates or interests in land. OMB Circular No. A-16, Coordination of Geographic Information and Related Spatial Data Activities (Draft 6/20/01 edition).

The above citations verify BLM's responsibility to maintain the "official records" pertaining to Federal Land Ownership Status. These "Land Status Records" are identified in Historical Indices (HI's) and depicted on Master Title Plats (MTP's). HI's are a chronological listing of all actions that affect the use of title to public land and resources for each township. MTP's are graphic representations of current Federal ownership, agency jurisdiction, and rights reserved to the federal government on private land.

Maintaining these official records is an ongoing process. Although we currently have a backlog of necessary notations, once an official action/request is received, every effort is made to update the official record as soon as possible.

Regarding your specific situation; it is unfortunate a deed executed over fifty years ago has not been noted to the "record". Until the BLM receives a request for notation from a benefitting agency, we are unable to note transactions. We suggest you contact the Army Corps of Engineers concerning the status of the deed in question.

Karen Montgomery – Realty Specialist, CA State Lead  
California State Office - BLM  
2800 Cottage Way, Suite 1928W  
Sacramento, CA 95825  
Office 916-978-4647 FAX 916-978-4657

Preservation begins with Conservation

---

**From:** [jd@johnanthonydavis.com](mailto:jd@johnanthonydavis.com) [<mailto:jd@johnanthonydavis.com>]  
**Sent:** Tuesday, September 04, 2012 11:03 AM  
**To:** Montgomery, Karen  
**Subject:** RE: From John Davis Requesting Assistance in regard to Land Deed to the U.S. from California

Hi,

I am happy to have your assistance. Take all the time you need.

Regards,

John Davis

----- Original Message -----

Subject: RE: From John Davis Requesting Assistance in regard to Land

Deed to the U.S. from California

From: "Montgomery, Karen" <[k15montg@blm.gov](mailto:k15montg@blm.gov)>

Date: Tue, September 04, 2012 10:43 am

To: "[jd@johnanthonydavis.com](mailto:jd@johnanthonydavis.com)"

<[jd@johnanthonydavis.com](mailto:jd@johnanthonydavis.com)>

We are working on your questions. We have only had 2 working days, and will need more time.

Karen Montgomery – Realty Specialist, CA State Lead  
California State Office - BLM  
2800 Cottage Way, Suite 1928W  
Sacramento, CA 95825  
Office 916-978-4647 FAX 916-978-4657

Preservation begins with Conservation

---

**From:** [jd@johnanthonydavis.com](mailto:jd@johnanthonydavis.com) [mailto:[jd@johnanthonydavis.com](mailto:jd@johnanthonydavis.com)]  
**Sent:** Tuesday, August 28, 2012 5:56 PM  
**To:** Montgomery, Karen  
**Subject:** RE: From John Davis Requesting Assistance in regard to Land Deed to the U.S. from California

Mrs. Montgomery,

Thank you for responding.

Under what provisions of law, or regulation, or policy, does BLM receive requests for notation from other agencies to note deeds in BLM records?

I understand you are not aware of any law that requires another agency to deliver documents to BLM.

However, there must be some statutory or regulatory authority which authorizes BLM to receive requests for notations into BLM records, delivered by other agencies.

Can you provide that information? If not, can you refer me to an entity at BLM that could provide that information?

Regards,

John Davis

----- Original Message -----

Subject: RE: From John Davis Requesting Assistance  
in regard to Land

Deed to the U.S. from California

From: "Montgomery, Karen" <[k15montg@blm.gov](mailto:k15montg@blm.gov)>

Date: Tue, August 28, 2012 5:21 pm

To: "[jd@johnanthonydavis.com](mailto:jd@johnanthonydavis.com)"  
<[jd@johnanthonydavis.com](mailto:jd@johnanthonydavis.com)>, "Easley,  
Elizabeth R" <[eeasley@blm.gov](mailto:eeasley@blm.gov)>

Cc: "Staszak, Cynthia" <[cstaszak@blm.gov](mailto:cstaszak@blm.gov)>

Mr. Davis,

You had 2 questions below...

I checked with our land records sections and we do not have any record of ever receiving a request from another agency to note the easement in question to our records. Until we receive a request, presumably from the Army Corps of Engineers (ACOE), we are unable to make this notation to the record.

We do not know of any law that requires other agencies to deliver documents to the BLM for notation. As the keeper of records we note what is delivered to us. If the ACOE does not deliver the documents to us, we can't make the notation. The ACOE would maintain their own official record.

We suggest that you talk to the ACOE to find out the status of this easement deed. If the ACOE delivers this deed to us with a request for notation we will process their request for notation.

Karen Montgomery – Realty Specialist, CA State Lead  
California State Office - BLM  
2800 Cottage Way, Suite 1928W  
Sacramento, CA 95825



Office 916-978-4647 FAX 916-978-4657

Preservation begins with Conservation

---

**From:** [jd@johnanthonydavis.com](mailto:jd@johnanthonydavis.com)  
[<mailto:jd@johnanthonydavis.com>]  
**Sent:** Thursday, August 23, 2012 12:38 PM  
**To:** Easley, Elizabeth R; Montgomery, Karen  
**Cc:** Staszak, Cynthia  
**Subject:** RE: From John Davis Requesting Assistance in regard to Land Deed to the U.S. from California

Hello Mrs. Easley and Mrs. Montgomery,

Thank you in advance for the assistance.

John Davis

----- Original Message -----

Subject: RE: From John Davis Requesting Assistance in regard to Land Deed to the U.S. from California  
From: "Easley, Elizabeth R" <[eeasley@blm.gov](mailto:eeasley@blm.gov)>  
Date: Tue, August 21, 2012 2:24 pm  
To: "Montgomery, Karen" <[k15montg@blm.gov](mailto:k15montg@blm.gov)>  
Cc: "[jd@johnanthonydavis.com](mailto:jd@johnanthonydavis.com)" <[jd@johnanthonydavis.com](mailto:jd@johnanthonydavis.com)>, "Staszak, Cynthia" <[cstaszak@blm.gov](mailto:cstaszak@blm.gov)>

Hi Karen!

This man called last week regarding Grant Deeds and how they are processed for recordation.

Thank you for addressing his questions?

Liz

---

**From:** [jd@johnanthonydavis.com](mailto:jd@johnanthonydavis.com)  
[<mailto:jd@johnanthonydavis.com>]  
**Sent:** Thursday, August 16, 2012 2:40 PM  
**To:** Easley, Elizabeth R  
**Subject:** From John Davis Requesting Assistance  
in regard to Land Deed to the U.S. from California  
**Importance:** High

U.S. BLM  
Att: E. Easley  
Re: Deed Required by U.S. Public Law 780

Dear Mrs. Easley,

Attached are the documents I said I would send to you. U.S. Public Law 780 required the deeding of all lands, easements, and rights of way necessary to complete the federal project.

The Congress approve those lands in the General Plan of Improvement, Enclosure No. 1 to U.S. Housed Document 389 in accordance with law.

The deed was signed by the County of Los Angeles Board of Supervisors Chairman. However, the cadastral description on the deed does not comport with the General Plan of Improvement, but only represents an easement over the main channel as mapped by the USACE Los Angeles District for me.

My question is when such land deeds from a State to the United States, does law require that BLM maintain any record of such deeds to the United States from an individual

State?

If so, what laws require BLM to receive such records and from what entity(s)?

Did the BLM receive any records to document that all lands, easements, and rights of way were transferred to the United States regarding U.S. Public Law 780, Project: Inlet at Playa del Rey, pursuant to the Rivers and Harbors Act of 1954 and as approved by the United State Congress in House of Representatives 389?

Thank you for your kind assistance,

John Davis  
PO 10152  
Marina del Rey Ca. 90295  
Ph. 310.795.9640

Copyright © 2003-2012. All rights reserved.

EXHIBIT 5

NORMAN Y. MINETA, Chairman  
Chair

THE CHIEF, Army Corps of Engineers  
Washington, DC 20315

JAMES L. OGBURN, Mississippi  
 JOHN J. RAYBURN, West Virginia  
 DONALD AMERICUS, Ohio  
 RONNIE LUGG, Virginia  
 ROBERT A. BOND, Pennsylvania  
 TIM VALENTINE, North Carolina  
 ROBERT G. LINDSEY, Illinois  
 ROBERT F. YARE, Jr., West Virginia  
 JAMES A. TRAMANT, Jr., Ohio  
 STEVE S. DEFAZIO, Oregon  
 CHARLEY KATZ, Louisiana  
 BOB CLINE, Tennessee  
 JERRY J. ROYCE, Michigan  
 MARK BARNER, Mississippi  
 JIMMIE HANCOCK, Texas  
 BETTIE GIBBS, Texas  
 GEORGE E. SANDHURST, Illinois  
 CLEAVE ROBERTS, Missouri  
 DICK SWIFT, New Hampshire  
 BUD KARNER, Alabama  
 BARBARA ROSS COULSON, Michigan  
 BLANCKE HOLMES, Oregon  
 District of Columbia  
 LUCIAN S. BLACKWELL, Pennsylvania

JEFFREY M. LEONARD, New York  
 JIM CUMMINGS, Arizona  
 LESLIE L. SYKES, Virginia  
 MARIA CANTONELL, Washington  
 PAT HAYES AND DENNIS, Missouri  
 KAREN CAMPBELL, Ohio  
 ROBERT W. BENTLEY, New Jersey  
 JAMES E. CLYBURN, South Carolina  
 CONNOR BROWN, Florida  
 MATTHEW OLEA, Georgia  
 JAMES A. BACCA, Michigan  
 DAN HANCOCK, Colorado  
 BOB SILVER, California  
 WALTER A. TUDOR, California  
 EDWIN RICHARD JOHNSON, Texas  
 PETER W. SANCIA, Missouri

PAUL SPENCER, Chief of Staff  
SANTA FE SPRING, CALIFORNIA

**U.S. House of Representatives**  
**COMMITTEE ON PUBLIC WORKS**  
**AND TRANSPORTATION**

SUITE 2186 MAYBURN HOUSE OFFICE BUILDING  
 WASHINGTON, DC 20516  
 (202) 325-4472

WILLIAM A. CLINGER, Jr., Pennsylvania  
 MICHAEL I. PETE, Wisconsin  
 EARLWOOD ADAMS, New York  
 JAMES M. HANCOCK, California  
 BILL WENGER, Missouri  
 JOHN J. BURNHAM, Jr., Tennessee  
 SUSAN HOLMAN, New York  
 WILLIAM W. DELUPE, Jr., New Hampshire  
 TOM HAINES, Missouri  
 ROBERT T. CLAYBURN, Maryland  
 JONATHAN BURR, Washington  
 TIM WYCHENBACH, Wisconsin  
 BILL BAKER, California  
 MAC COLLINS, Georgia  
 JAY C. SIM, California  
 DAVID A. LEVY, New York  
 LITTLE JOHN, California  
 BOB FRANKS, New Jersey  
 PETER J. BLUTE, Massachusetts  
 EDWARD P. BURN, California  
 JOHN L. MACE, Florida  
 PETER ROBERTSON, Michigan  
 JACK CLAIR, New York  
 HERMAN J. ENLERS, Michigan

Jack Schindler, Member Staff Director

**COMMITTEE ON PUBLIC WORKS AND TRANSPORTATION**  
**U.S. HOUSE OF REPRESENTATIVES**  
**WASHINGTON, D.C.**

**RESOLUTION**

Marina del Rey, California  
 Docket 2455

Resolved by the Committee on Public Works and Transportation of the United States House of Representatives, That the Secretary of the Army is requested to review the report of the Chief of Engineers on Playa del Rey Inlet and Basin, Venice, California, published as House Document 389, Eighty-third Congress, Second Session, and other pertinent reports, to determine whether modifications of the recommendations contained therein are advisable at the present time, in the interest of navigation, hurricane and storm damage reduction, environmental restoration, and other purposes at Marina del Rey Harbor, Los Angeles, California, with consideration given to the disposal of contaminated sediments from the entrance channel required under the existing operation and maintenance program at Marina del Rey Harbor.

Adopted: September 28, 1994

ATTEST:   
 NORMAN Y. MINETA, Chair

**EXHIBIT 6**

-----  
DEPARTMENT OF DEFENSE Department of the Army; Corps of Engineers  
Notice of Intent To Prepare an Environmental Impact Statement/  
Environmental Impact Report for the Ballona Creek Ecosystem Restoration  
Feasibility Study, Los Angeles County, CA AGENCY: Department of the  
Army, U.S. Army Corps of Engineers, DoD. ACTION: Notice of intent. --  
-----

SUMMARY: The Los Angeles District intends to prepare an Environmental  
Impact Statement/Environmental Impact Report (EIS/EIR) to support a  
cost-shared ecosystem restoration feasibility study with the Santa  
Monica Bay Restoration Commission. The proposed project study areas has  
been degraded by encroachment of non-native plants, placement of fill  
from Marina Del Rey, interruption of the hydrologic regime, trash  
accumulation, and varied attempts at bank protection along the creek  
using rock and concrete. Direct benefits of the proposed project  
include improved habitat and water quality, reductions in waste and  
trash, and aesthetics. The watershed is an important resource for both  
recreational uses and for fish, and wildlife and further degradation  
could jeopardize remaining. The purpose of the feasibility study is to  
evaluate alternatives for channel modification, habitat restoration  
(coastal and freshwater wetlands and riparian), recreation, and related  
purposes along the lower reach of the Ballona Creek. DATES: A public  
scoping meeting will be held on September 29, 2005 at 6 p.m.

ADDRESSES: U.S. Army Corps of Engineers, Los Angeles District, CESPL-  
PD, P.O. Box 532711, Los Angeles, CA 90053 and Santa Monica Bay  
Restoration Commission, 320 West 4th Street, Los Angeles, CA 90013.

FOR FURTHER INFORMATION CONTACT: Shannon Dellaquila, Project  
Environmental Manager, at (213) 452-3850 or Malisa Martin, Project  
Study Manager at (213) 452-3828. SUPPLEMENTARY INFORMATION: 1.

Authorization This study was prepared as an interim response to  
the following authorities provided by Congress under Section 216 of  
the Flood Control Act of 1970, which states: The Secretary of the  
Army, acting through the Chief of Engineers, is authorized to review  
the operation of projects the construction of which has been completed  
and which were constructed by the Corps of Engineers in the interest  
of navigation, flood control, water supply, and related purposes, when  
found advisable due the significantly changed physical or economic  
conditions, and to report thereon to Congress with recommendations on  
the advisability of modifying the structures or their operation, and  
for improving the quality of the environment in the overall public  
interest; supplemented by House Resolution on Public Works and  
Transportation dated September 28, 1994 which states: The

Secretary of the Army is requested to review the report of the Chief  
of Engineers on Playa del Rey Inlet and Basin, Venice, California,  
published as House Document 389, Eighty-third Congress, Second

Session, and other pertinent reports, to determine whether  
modifications of the recommendations contained therein are advisable  
at present time, in the interest of navigation, hurricane and storm  
damage reduction, environmental restoration, and other purposes at  
Marina del Rey Harbor, Los Angeles, California, with consideration  
given to disposal of contaminated sediments from the entrance channel  
required under the existing operation and maintenance program at  
Marina del Rey. 2. Background The Ballona Creek Ecosystem

Restoration study area lies within Los Angeles County, CA and includes portions of Marina del Rey, Culver City, Playa del Rey, and the City of Los Angeles. The study area, a component of the greater Ballona Creek Watershed, includes the lower reach of Ballona Creek extending southwest from Cochran Avenue, in Los Angeles, to Pacific Ocean in Marina del Rey. specific features of the Ballona Creek watershed, including existing and historic wetland areas, the Ballona Lagoon, Del Rey Lagoon, Venice Canal, Grand Canal, the Oxford Drain and the Ballona Channel and tributaries, will be addressed in this study. The greater Ballona Creek system drains a watershed of approximately 329 square kilometers (81,300 acres), and is the largest tributary that drains into the Santa Monica Bay. Ballona Creek collects runoff from several partially urbanized canyons on the south slopes of the Santa Monica Mountains as well as from intensely urbanized areas of West Los Angeles, Culver City, Beverly Hills, Hollywood, and parts of Central Los Angeles. The urbanized areas account for 80 percent of the watershed area, and the partially developed foothills and mountains make up the remaining 20 percent. The watershed boundary includes the Santa Monica Mountains on the north, the unincorporated area known as Baldwin Hills, and the City of Inglewood on the south. The Ballona Creek Ecosystem Restoration study footprint's southern boundary is defined by the Westcheste Bluffs, which run southwest from the San Diego (405) Freeway beyond Loyola Marymount University. The western boundary extends from the Pacific Ocean. The eastern boundary begins where Ballona Creek daylights at Cochran Avenue and Venice Boulevard in a section of Los Angeles known as the Mid City. Tributaries of Ballona Creek include Centinela Creek, Sepulveda Canyon Channel, Benedict Canyon Channel, and numerous storm drains. The Ballona Creek watershed ecosystem has been altered by intense land development, encroachment of non-native plants, trash accumulation, and varied attempts at bank protection along the creek using rock and concrete. Although an important function of the Ballona Creek is as a flood control channel, the lower watershed is still an important resource for both recreational uses and for fish and wildlife habitat. Further impairment could jeopardize remaining habitat. This study will evaluate opportunities for habitat restoration (including wetland and riparian habitat), improvements to water quality, trash mitigation, and recreation and related purposes along the lower reach of the Ballona creek.

3. Problems and Needs At least ninety (90) percent of historic coastal wetlands in California have been lost due to filling, dredging, flood control and intensive development. Within the Lower Ballona Creek Watershed, remaining fragmented wetland areas have been degraded due to diminished hydraulic function, poor water quality and introduction of exotic plants and animals. While functioning wetland systems and riparian habitat remain, they are stressed. Channelization of the Ballona Creek and filling of historic wetland and riparian areas have contributed to degradation and loss of habitat due to impeded tidal exchange and circulation. Contaminated stormwater runoff and trash loading has degraded Ballona Creek water quality. Habitat alteration and loss has decreased biodiversity and overall ecological health, threatening the survival of native endangered species such as the California least tern (*Sterna antillarum* brown), snowy plover (*Charadrius alexandrinus*), and the Belding's Savannah Sparrow (*Sandwichensis beldingi*). The current design of the Flood Control channel has resulted in a lack of recreational opportunities and is considered aesthetically challenged. At present there is no integrated approach and partnership amongst stakeholders to resolve lower Ballona Creek in-stream and wetland



degradation issues, which has led to uncoordinated and sometimes redundant and unsuccessful improvement measures.

4. Proposed Action and Alternative The Los Angeles District will investigate and evaluate all reasonable alternatives to address the problems and need stated above. In addition to a without project (No Action) Alternative, both structural and non-structural environmental measures will be investigated. An assessment of the feasibility of removing impervious surfaces from the Ballona Channel will also be evaluated. Proposed restoration measures include: re-grading and removal of fill, remove invasive and non-native plant species, reintroduction of a water source and installation of native plants to restore previously filled coastal wetlands. Other measures to be evaluated include features to improve or restore tidal regime in Oxford Basin, the Grand and Venice canals, and Ballona and Del Rey Lagoons; the potential for in stream wetland development in Centinela, Sepulveda and Ballona Creek; sediment loading in the upper watershed; and related recreation and educational opportunities.

5. Scoping Process The scoping process is on-going, and has involved preliminary coordination with Federal, State, and local agencies and the general public. A public scoping meeting is scheduled for Thursday September 29th from 6-8 p.m. at the Rotunda Room of the Veteran's Memorial Building, 4117 Overland Avenue, Culver City, CA. This information is being published in the local news media, and a notice is being mailed to all parties on the study mailing list to ensure that public will have an opportunity to express opinions and raise any issues relating to the scope of the Feasibility Study and the Environmental Impact Study/Environmental Impact Report. The public as well as Federal, state, and local agencies are encouraged to participate by submitting data, information, and comments identifying relevant environmental and socioeconomic issues to be addressed in the study. Useful information includes other environmental studies, published and unpublished data, alternatives that could be addressed in the analysis, and, potential mitigation measures associated with the proposed action. All comments will be considered in the project development. Concerns may be submitted in writing to the Santa Monica Bay Restoration Commission, or to the Los Angeles District (see ADDRESSES). Comments, suggestions, and request to be placed on the mailing list for announcements should be spl01.usace.army.mil. Availability of the Draft EIS/EIR The Draft EIS/EIR is scheduled to be published and circulated in December 2007, and a public hearing to receive comments on the Draft EIS/EIR will be held after it is published. Dated: September 13, 2005. Alex C. Dornstauder, Colonel, U.S. Army, District Engineer. [FR Doc. 05-18651 Filed 9-19-05; 8:45 am] BILLING CODE 3710-KF-M

**Ballona Creek Eco Restoration 104797**

| Fiscal Year  | FED SHARE           |                     |
|--------------|---------------------|---------------------|
|              | ALLOCATION          | EXPENDITURE         |
| 2005         | \$ 107,300          | \$ 98,094           |
| 2006         | \$ 198,000          | \$ 155,613          |
| 2007         | \$ 450,000          | \$ 334,062          |
| 2008         | \$ 344,000          | \$ 319,716          |
| 2009         | \$ 249,000          | \$ 369,862          |
| 2010         | \$ 565,000          | \$ 400,983          |
| 2011         | \$ 99,775           | \$ 179,922          |
| <b>Total</b> | <b>\$ 2,013,075</b> | <b>\$ 1,858,252</b> |

**Ballona Creek Eco Restoration 104797**

| Fiscal Year  | FED SHARE           |                     |
|--------------|---------------------|---------------------|
|              | ALLOCATION          | EXPENDITURE         |
| 2005         | \$ 107,300          | \$ 98,094           |
| 2006         | \$ 198,000          | \$ 155,613          |
| 2007         | \$ 450,000          | \$ 334,062          |
| 2008         | \$ 344,000          | \$ 319,716          |
| 2009         | \$ 249,000          | \$ 369,862          |
| 2010         | \$ 565,000          | \$ 400,983          |
| 2011         | \$ 99,775           | \$ 179,922          |
| <b>Total</b> | <b>\$ 2,013,075</b> | <b>\$ 1,858,252</b> |

## CHAPTER 13

### ACCOUNTING FOR CIVIL WORKS COST SHARED PROJECTS

13-1. **General.** The purpose of this chapter is to provide accounting guidance and procedures for applying non-Federal contributions toward the cost of project planning, engineering, design, construction, and operations and maintenance of Civil Works cost shared projects.

a. The Water Resources Development Act of 1986, Public Law 99-662, as amended, (hereinafter “WRDA 86” or “the Act”) entered the Corps of Engineers into a new era of project financing through cost sharing with various non-Federal sponsors (public entities). Although the acceptance of funds from private parties is allowed under section 4, Rivers and Harbor Act (38 Stat. 1053; 33 U.S.C. 560) navigation authority, and other authorities, it is HQUSACE policy that funds shall be accepted only from duly appointed public entities. See ER 1165-2-30 for further guidance.

b. WRDA 86 specifies that the cost sharing provisions set forth therein apply to any studies for a water resources project commenced after November 17, 1986, or any water resources project, or any separable element thereof (as defined in the Act), for which a contract for physical construction had not been awarded before November 17, 1986. The Act further provides that, unless otherwise specified, the cost sharing provisions of Title I of the Act shall apply to all projects authorized therein. WRDA 86 further states that prior to initiating work on a project, other than hydropower, a legally binding cooperative agreement must be executed between the Department of the Army and the non-Federal sponsor to document the Government’s responsibility and the non-Federal sponsor’s responsibility for the project including, but not limited to, paying the non-Federal share of the costs of construction, paying 100 percent of the costs of the operation, maintenance, replacement, and rehabilitation costs, and holding and saving the Government free from damages. Similar requirements are included in the Act regarding planning and engineering of a project authorized by the Act. Model cost sharing agreements for feasibility studies (Feasibility Cost Sharing Agreement (FCSA)), for preconstruction, engineering and design (Design Agreement (DA)), and for construction, operation and maintenance (Project Cooperation Agreement (PCA)) of water resources projects have been approved by HQUSACE and by the Assistant Secretary of the Army (Civil Works) (ASA (CW)) for many of the Corps missions and authorities. The approved model agreements are maintained on the website for Civil Works:  
[http://www.usace.army.mil/civilworks/cecwp/branches/policy\\_compliance/ccpca.htm](http://www.usace.army.mil/civilworks/cecwp/branches/policy_compliance/ccpca.htm)

Further guidance regarding cost sharing requirements may be found in ER 1165-2-131, ER 1105-2-100, as well as in other engineering regulations, circulars and pamphlets, and Planning, Policy,

and Project Management Guidance Letters.

c. Many pre-WRDA 1986 projects are still active, and these projects may be subject to different cost-sharing obligations and existing assurance agreements or local cooperation agreements, which contain the contractual agreement of the non-Federal sponsor regarding the project cost-sharing obligations and the method of payment under the specific project authority. Unless these pre-WRDA 86 projects, or a separable element thereof, have been expressly made subject by Congress to the cost-sharing requirements of WRDA 86, as amended, the Government cannot unilaterally alter the contractual obligations of the non-Federal sponsor beyond those obligations set forth in the pre-existing cost sharing agreement executed by the sponsor.

d. Interdisciplinary teams led by the Project Manager are recommended by HQUSACE for development, negotiation and execution of PCAs, FCSAs, DAs, and escrow agreements. It is recommended that the team include a Resource Management (RM) representative. The RM representative must be familiar with the accounting procedures for all agreements and cost sharing procedures of all references in appendix A.

### 13-2. Policy.

a. General. The Corps of Engineers Financial Management System cost share programming reflects the financial requirements specified in law, regulation, and study or project specific cooperative agreements between the Government and non-Federal sponsors for each cost-share project. For Congressional Add projects with unique cost-sharing allowances during study, design, or construction, the PM will provide RM with copies of the authorizing language supporting the project cost-sharing allowance, with additional support from OC, if requested by RM. When a purchase request is certified, the Federal Government and all non-Federal sponsors must have their respective proportional shares (e.g., Federal cash, sponsor cash, or authorized and approved sponsor credit) available. (See PM Guidance letter No. 11 Revised, SUBJECT: Provisions of Non-federal Cash for Construction of Civil Works Projects and Separable Elements at:  
[http://www.usace.army.mil/inet/functions/cw/cecwp/branches/policy\\_compliance/pmg11.htm](http://www.usace.army.mil/inet/functions/cw/cecwp/branches/policy_compliance/pmg11.htm)

Only the Secretary of the Army or the ASA (CW) can waive the non-Federal sponsor's proportionate share requirements. If there is no such waiver and the Government's and/or any non-Federal sponsor's proportionate share (net of any authorized and approved creditable work) is not available when a purchase request is processed, then the purchase request will not be certified. Purchase requests cannot be certified until the Government and each non-Federal sponsor's proportionate share requirements are met.

b. Feasibility Phase. Section 105(a) of WRDA 86 specifies the cost sharing requirements for studies that were initiated after 17 November 1986. Feasibility studies are cost shared 50% Federal and 50% non-Federal and are typically accomplished with General Investigations funding.

As originally enacted in WRDA 86, at least 50% of a non-Federal sponsor's share (25% of the total feasibility phase cost) was required to be in cash. With the passage of WRDA 2000, P.L. 106-541, Section 225, the non-Federal sponsor may now provide 100% of its share in "in-kind service" credit. No credit may be given to the non-Federal sponsor for work performed prior to execution of the FCSA or after completion of the feasibility phase.

(1) The Project Manager assigned to the feasibility study will coordinate actions with the RM representative prior to completion of the negotiations on the FCSA with the non-Federal sponsor. Coordination and accounting mechanisms will be established for: allocating and tracking non-Federal cash contributions, crediting the value of approved in-kind service contributions, and distribution of charges against the Federal and non-Federal sponsor accounts. They will document the effective, departmental overhead and any other rates, and identify increases that could trigger an amendment to the FCSA, or Project Management Plan (PMP).

(2) The Project Manager coordinates a draft FCSA with RM to ensure compliance of the following: procedures for receipt and accounting of non-Federal sponsor cash funds; establishment and handling of escrow accounts, if used; prohibitions pertaining to commingling of funds; the direct charging rule for recording direct labor cost; frequency of charges against the non-Federal sponsor contributed fund accounts; crediting the value of approved in-kind contributions; the F&A reporting products and their interpretation; circumstances precipitating increases in effective and departmental overhead rates; partial reconciliation of the accounts for the non-Federal sponsor and Federal end-of-year budgetary requirements; end of study reconciliation mechanism; and the provision and maintenance of accounting records for inspection and audit by Federal or non-Federal sponsor representatives.

c. Credits for work-in-kind during Feasibility Phase. In-kind services represent study work performed by the non-Federal sponsor during the feasibility phase per Section 105(a) of WRDA 86, as amended, for which credit may be given and counted towards the required non-federal contribution. A PMP is the basis for assigning tasks between the Government and the non-Federal sponsor and for establishing the value for credit for in-kind services. Examples of in-kind services are services, materials, supplies and other in-kind work items other than cash necessary to prepare the feasibility report. The determination of the initial dollar value of in-kind products or services will be based on negotiation of a detailed Government estimate and a non-Federal sponsor proposal. The value of in-kind services will be stated as fixed fee amounts determined by applying applicable Federal regulations, including

OMB Circular A-87. Acceptance of the product will be as described in the PMP.

d. Preconstruction Engineering and Design (PED) Phase.

(1) Section 105(c) of WRDA 86 specifies that the cost sharing for design of projects will be shared in the same percentages as the project purpose. CECW-AG Memorandum, 3 August 1998, Subject: Model Design Agreement, requires that the Government and the non-Federal sponsor execute a design agreement for all Preconstruction Engineering and Design activities funded by General Investigations, and all engineering and design activities funded by either Construction, General or Operations and Maintenance, General appropriations with certain limited exceptions set forth therein. Since most project purposes have different cost sharing formulas, HQUSACE and ASA (CW) developed the model DA using 75/25 percent cost sharing. To ensure costs of design are ultimately shared in the same percentages as the project purpose, once design is complete total design costs are included in total project costs in the PCA for the project. Any adjustments required ensuring the non-Federal sponsor has contributed the correct percentage of total design costs are accomplished by adjusting the cash requirement from the non-Federal sponsor in the first year of construction. It is important to note that unlike Section 105(a) of WRDA 86, Section 105(c) of WRDA 86 does not authorize or permit any in-kind services to meet a portion of non-Federal sponsor contributions during design.

(2) Section 105(b) of WRDA 86 specifies the cost sharing for projects authorized in WRDA 86 for Planning and Engineering only. Non-Federal sponsors must contribute 50 percent of the cost of planning and engineering during the period of planning and engineering. The costs included herein are all costs necessary to produce a feasibility report. Once the period of planning and engineering is complete, the Government and non-Federal sponsor must execute a DA to cost share the costs of design.

(3) All Other PED. These costs may be incurred under several classes below: All PED costs incurred subsequent to the feasibility study, other than costs incurred during the period of planning and engineering discussed in 2. above, are considered a part of, and included in, the total project cost to be cost shared and included in the PCA. The PED costs are to be treated as a component of the first year construction costs and included in the non-Federal sponsor's first year cash requirements.

(a) Continuing Planning and Engineering. All such costs are subject to cost sharing, if incurred on or after 1 October 1985.

(b) Advance Engineering and Design.

e. Construction. The draft PCA is sent through RM for comment to insure the PCA cost sharing provisions will track and comply with established accounts. Coordination and accounting mechanisms will be established for: allocating and tracking non-Federal sponsor cash contributions, crediting for the value of authorized and approved Lands, Easements, Rights-of-Way, and initial and final Relocations, and Disposal Areas (except for general navigation projects/features), Section 104/215 and other authorized credits to the non-Federal sponsor's cost share; and distribution of charges against Federal and non-Federal sponsor accounts. Project cost estimates reflecting the detailed current schedule and cost share requirements are prepared annually by the project manager/programmer. The project programmer creates and updates the Cost Share Control Record in CEFMS that includes this summarized information annually.

(1) Non-Federal sponsor contributions of Project Cost. The non-Federal sponsor cost sharing and project financing responsibilities must be determined for each project based upon the statutory authority as spelled out in the cost sharing agreement and the project. Except as discussed in the next paragraph, the non-Federal sponsor must provide its share of total project costs during the period of construction. The non-Federal sponsor has flexibility to determine whether to make the total estimated non-Federal share of construction cost available prior to the start of construction or incrementally over the period of construction. The specific policy is generally outlined in ER 1165-2-131 and updated by Policy and Project Management Guidance Letters listed on the Planning and Policy Website.

(2) Authorities Allowing Deferred Payment by the non-Federal sponsor.

(a) For commercial navigation projects, Section 101(a)(1) of WRDA 86 provides that a portion of the non-Federal sponsor's share will be paid during construction. Section 101(a)(2) of WRDA 86 requires an additional 10 percent of the cost of general navigation features to be paid by the non-Federal sponsor over a period not to exceed 30 years at an interest rate determined pursuant to Section 106 of WRDA 86.

(b) In special circumstances (see ER 1165-2-131) where non-Federal sponsors request, non-Federal sponsor financing may be deferred under Sections 101(d) and 103(l) if approved by the Assistant Secretary of the Army (Civil Works) (ASA (CW)). In such an instance, the Government will finance the construction costs from Federal appropriations and the non-Federal sponsor will repay its share over time, plus interest at a stated rate. When this approach is taken, Interest During Construction (IDC) will be assessed, as well as interest during the repayment phase, since the Government is incurring an interest cost in financing the non-Federal share. All interest will be recorded in the Federal project account as miscellaneous receipts funds returned to the U.S. Treasury. Interest methodology is defined in ER 1165-2-131, Appendix I. This methodology will be followed for all projects subject to the provisions of WRDA 86, P.L. 99-662,



ER 37-1-30  
Change 2  
31 Dec 03

but will not be retroactively applied to projects when construction was begun under previous legislative authorities.

f. Flood Control and Coastal Emergencies.

(1) Cost-sharing provisions under natural disaster procedures specified in ER 500-1-1 require that 20 percent of the cost to rehabilitate a non-Federal levee be provided by non-Federal sponsors. This contribution may be cash or in-kind services provided during the period of construction.

(2) In certain circumstances, notably for construction of wells to provide emergency drinking water, any construction of wells by USACE will be paid by the applicant. USACE may construct wells only when commercial or other sources cannot construct them within a reasonable time. The purpose of the well will be for human and livestock consumption only.

Reference ER 500-1-1.

g. Inland Waterways Transportation. Projects authorized under Section 102 of WRDA 86 are to be financed in part through transfer appropriation 96-20X8861 (Inland Waterways Trust Fund). The Inland Waterways Trust Fund will be used to pay 50 percent of total construction cost. The term "construction" as used in Section 102 of WRDA 86 includes planning, designing, engineering, surveying, the acquisition of all lands, easements, and rights-of-way necessary for the project, including lands for disposal of dredged material, and relocations necessary for the project.

h. Operation, Maintenance, Repair, Replacement and Rehabilitation (OMRR&R). The non-Federal cost of OMRR&R of projects shall be in accordance with the statutory authority for the project.

i. Reimbursement For Advance Non-Federal Construction of Authorized Federal Harbors and Inland Harbor Improvement.

(1) Section 204(e) of WRDA 86, as amended, provides authority to reimburse a non-Federal sponsor for construction of an authorized Federal harbor or inland improvement or separable element thereof provided that certain statutory requirements are met.

(2) In accordance with the statutory authority, after project authorization and before initiation of construction of the project or separable element, the Secretary of the Army must approve the plans of construction of the project by the non-Federal interest, the non-Federal interest must execute an agreement to pay the non-Federal share, if any, of the cost of operation

and maintenance of the project, and the Secretary must determine before plan approval that the project or separable element of the project is economically justified and environmentally acceptable. Reimbursement cannot be made until appropriated funds are available and the Secretary has certified that the work has been performed in accordance with applicable permits and approved plans.

j. Lands, Easements, Rights-of-Way, Relocations and Disposal Areas (LERRD).

(1) In addition to cash requirements, the non-Federal sponsors are required, under many project authorities, to provide all lands, easements, rights-of-way, and to perform or assure performance of relocations (see paragraph (3) below) or bear the costs of such work if performed by the Government on behalf of the non-Federal sponsor. Except for commercial navigation projects, non-Federal sponsors also are generally required to provide all dredged or excavated material disposal areas.

For commercial navigation projects, the non-Federal sponsor does not generally provide dredged material disposal areas. They must provide the underlying lands, but the disposal area features will be treated as cost shared general navigation features. However, in order to determine the responsibility for a specific project, the statutory authority for the project must be examined. (See ER 1165-2-131 and chapter 12 of ER 405-1-12.)

(2) The non-Federal sponsor shall receive credit toward its share of total project costs for the fair market value of the lands, easements, and rights-of-way that it provides for the project and for the incidental costs of acquiring such interests. Fair market value, and the credit amount to be afforded shall be determined in accordance with the requirements of the cost-sharing agreement executed by the Government and the non-Federal sponsor.

(3) The general policy for performing and cost sharing of relocations, removal or alteration of highway bridges, railroad bridges, utilities and certain structures has been addressed in a series of policy guidance letters (PGL Nos. 1, 2, 2R 44 and 45). They may be found on the web at:  
[http://www.usace.army.mil/inet/functions/cw/cecwp/branches/guidance\\_dev/pgls/pgl101.htm](http://www.usace.army.mil/inet/functions/cw/cecwp/branches/guidance_dev/pgls/pgl101.htm)  
[http://www.usace.army.mil/inet/functions/cw/cecwp/branches/guidance\\_dev/pgls/pgl02.htm](http://www.usace.army.mil/inet/functions/cw/cecwp/branches/guidance_dev/pgls/pgl02.htm)  
[http://www.usace.army.mil/inet/functions/cw/cecwp/branches/guidance\\_dev/pgls/pgl02r.htm](http://www.usace.army.mil/inet/functions/cw/cecwp/branches/guidance_dev/pgls/pgl02r.htm)  
[http://www.usace.army.mil/inet/functions/cw/cecwp/branches/guidance\\_dev/pgls/pgl44.htm](http://www.usace.army.mil/inet/functions/cw/cecwp/branches/guidance_dev/pgls/pgl44.htm)  
[http://www.usace.army.mil/inet/functions/cw/cecwp/branches/guidance\\_dev/pgls/pgl45.htm](http://www.usace.army.mil/inet/functions/cw/cecwp/branches/guidance_dev/pgls/pgl45.htm)

Specific project statutory authority may provide a different cost-sharing responsibility.

k. Methods for Providing Non-Federal Funds.

(1) General. For projects involving a single or lump sum contract to be completed in one fiscal year or a project that will be completed in one fiscal year, the non-Federal sponsor shall provide its full cash requirement on or before the scheduled date of issuance of the solicitation of the first construction contract. For projects that will take more than one fiscal year to complete, the non-Federal sponsor may provide its share in periodic payments. The timing of these payments may be on a Federal fiscal year, quarterly, or fiscal year of the non-Federal sponsor basis in accordance with the cost-sharing agreement for the project. The non-Federal sponsor's payment may be made by any of the methods of payment (check, escrow account, letter of credit, or electronic funds transfer) outlined in the cost-sharing agreement executed by the Government and the non-Federal sponsor.

(2) Check.

(3) Escrow Accounts.

(a) Non-Federal sponsors of water resource projects, especially those projects that will be constructed over a period of years, may wish to provide their required contributions in an interest bearing escrow account. The escrow account provides a means for the non-Federal sponsor to earn interest on its funds and ensures that funds are available for use immediately by the Government when needed. Funds are not available for obligation purposes by the Government until withdrawn from the non-Federal sponsor's escrow account and deposited into the U.S. Treasury. Usually, the District Commander or another designated official for deposit will withdraw funds in escrow into the U.S. Treasury in increments as needed. Approval from HQUSACE (CECC-G) is required only when escrow agreements differ from the model escrow agreement. Further discussion is provided in ER 1165-2-30, ER 1165-2-131, ER 37-1-30, in Memorandum, CECC-ZA, 8 October 1997, subject: Escrow Agreements in Support of Agreements Other than Project Cooperation Agreements, as amended by Memorandum, CECW-PG, 28 September 2000, Subject: Revision to Model Escrow Agreement, and references cited therein.

(1) The model escrow agreement found in those ERs has been modified. The revised model is located at the following Internet address:

[http://www.usace.army.mil/civilworks/cecwp/branches/policy\\_compliance/ccpca.htm](http://www.usace.army.mil/civilworks/cecwp/branches/policy_compliance/ccpca.htm)

(b) Escrow accounts must meet certain criteria. The financial institution must be financially secure. The financial institution that holds the escrow account must hold a national charter (i.e., be a member of the Federal Reserve) or at least be insured by the Federal Deposit

Insurance Corporation (FDIC). In addition, the deposit of funds must be irrevocable. The non-Federal sponsor must not be able to withdraw the funds until the Government has certified that no additional funds will be needed. The funds will not be used for speculative investment. Any investment by the financial institution must be a direct obligation of the Federal Government (e.g., Treasury bills) or obligations of Federal agencies guaranteed by the Federal Government (e.g., certificates issued by the Government National Mortgage Association), or in a money market mutual fund consisting solely of such obligations.

(4) Letter of Credit. The non-Federal sponsor may wish to provide an irrevocable letter of credit for its share of project costs. A letter of credit is similar to an escrow account. With a letter of credit, a financial institution guarantees to the Federal Government that funds are available upon request from the non-Federal sponsor to meet the required cash outlays. HQUSACE (CECC-G) must approve the letter of credit. A suggested example of a letter of credit has been placed on the HQUSACE Civil Works website at:

[http://www.usace.army.mil/civilworks/cecwp/branches/policy\\_compliance/ccpca.htm](http://www.usace.army.mil/civilworks/cecwp/branches/policy_compliance/ccpca.htm)

(5) Electronic Funds Transfer.

(6) Deferred Payments. Deferred payments by non-Federal sponsors are covered in ER 1165-2-131 and the mechanisms would need to be specifically provided in the project cooperation agreement.

(7) There are occasions when non-Federal sponsors may wish to meet their cost sharing responsibilities at least in part with funds they have received from the Government. As a general rule, non-Federal shares of project cost are to be satisfied through the use of non-Federal funds. Federal funds may not be used to meet the non-Federal sponsor's share of project costs unless the expenditure of such funds is expressly authorized by statute as verified in writing by the granting agency. (See ER 1165-2-131.)

I. Voluntary contributions for recreation and natural resources activities, 33 USC 2325.

(1) Acceptance. USACE is authorized to accept contributions of cash, funds, materials, and services from persons, including governmental entities but excluding the project sponsor in connection with management of recreation and natural resources activities at water resources development projects.

(2) Deposit. Any cash or funds received shall be deposited in the U.S. Treasury into account "Contributions and Advances, Rivers and Harbors, Corps of Engineers (96X8862)" and shall be available until expended.

ER 37-1-30  
Change 2  
31 Dec 03

m. Challenge Partnership Agreements program for the management of recreation and natural resources activities, 33 USC 2328.

(1) General. USACE is authorized to develop and implement a program to share the cost of managing recreation and natural resources activities at water resources development projects.

(2) Cooperative agreements. To implement this program, USACE is authorized to enter into cooperative agreements with non-Federal public and private entities to provide for operation and management of natural resources activities at Civil Works projects.

(3) Contributions. USACE may accept contributions of funds, materials, and services from non-Federal public and private entities for the Challenge Partnership Agreements program. Any funds received shall be deposited in the U.S. Treasury into account "Contributions and Advances, Rivers and Harbors, Corps of Engineers (96X8862)" and shall be available until expended.

13-3. Procedures.

a. Cost Shared Accounting Procedures can be found at:  
<http://www.usace.army.mil/inet/functions/rm/finance/finance.htm>

b. Financial Management System. The Corps of Engineers Financial Management System (CEFMS) user manual at <http://rmf31.usace.army.mil/cefmsdoc> provides detailed financial system procedures for cost sharing management.

APPENDIX A

Required Publications

- P.L. 99-662 (The Water Resources Development Act of 1986)
- P.L. 100-676 (The Water Resources Development Act of 1988)
- P.L. 106-541 (The Water Resources Development Act of 2000)
- 38 Stat. 1053; (Rivers and Harbor Act of 1915) 33 U.S.C. 560, Section 4
- OMB Circular A-87 (Cost Principles for State and Local Governments)
- EFARS (Engineer Federal Acquisition Regulation Supplement)
- ER 37-1-30 (Accounting and Reporting)
- ER 405-1-12 (Real Estate Handbook)
- ER 500-1-1 (Natural Disaster Procedures)
- ER 1105-2-100 (Guidance for Conducting Civil Works Planning Studies)
- ER 1165-2-30 (Acceptance and Return of Required, Contributed or Advanced Funds for Construction or Operation)
- ER 1165-2-120 (Reimbursement for Advance Non-Federal Construction of Federally Authorized Harbor and Inland Harbor Improvements)
- ER 1165-2-131 (Project Cooperation Agreements for New Start Construction Projects)

## APPENDIX B

### Final Accounting Report

13-B-1. The terms of the FCSA, PCA, and Design Agreement require that the Corps must provide the non-Federal sponsor with a final accounting report of total study/project cost. The project manager and the F&A office will prepare the final accounting report. The project manager, RM representative and non-Federal sponsor may develop the final accounting report format during the preliminary negotiations of the FCSA or PCA. It is recommended that a draft report format be presented to the non-Federal sponsor for concurrence. The F&A office must ensure that the final report agrees with the cost recorded in the official accounting records (CEFMS). Commanders and project managers must ensure that responsibilities are clearly assigned, since the report may require a billing or refund to the non-Federal sponsor. An independent review of the final accounting report must be performed prior to billing or returning funds to the sponsor. CEIR reviews the USACE records and DCAA reviews the sponsor records.

13-B-2. The percentage of total project cost which the non-Federal sponsor must provide is normally a joint effort between Project Management, Resource Management, Counsel, and Real Estate and determined based on Federal laws. Under P.L. 99-662, cost sharing requirements for certain project feature/purposes are different from others. The final accounting report must contain clear splits where different project purposes exist. The cost accountant must coordinate with the project manager to determine if different project purposes are involved and hence the applicable cost share percentages have been established prior to start of work.

13-B-3. The terms of the model FCSA require that the final accounting report of study cost be provided to the non-Federal sponsor within 90 days of the study completion. The terms of the FCSA require the following items to be included in the final accounting report:

- (1) Government disbursement of Federal Funds.
- (2) Cash contributions from the sponsor.
- (3) Credits for the negotiated cost of the non-Federal sponsor.

Within 30 days after the final accounting report, the Government shall refund to the sponsor the excess of cash contributions and credits over 50 percent of total study cost, if any, subject to the availability of appropriation funds. Within 30 days after the final accounting report, the non-Federal sponsor shall provide the Government any cash contributions required so that total sponsor's share equals 50 percent of total study cost.

13-B-1

13-B-4. The terms of the PCAs for civil works projects require the Corps, upon completion of construction and resolution of all relevant claims and appeals, to compute total cost of construction and tender to the non-Federal sponsor a final account of the sponsor's share of total project cost. The final accounting report should be provided within 90 days.

a. In the event that the total contributions by the non-Federal sponsor are less than its required share, the sponsor shall, no later than 90 calendar days after receipt of written notice, make cash payment to the Government to meet its required share of project cost.

b. Structural flood control model PCA. See Article VI D for requirements regarding refund of the non-Federal sponsor's contribution.

c. Harbor model PCA.

13-B-5. If interest on deferred payments or during construction applies, it must be computed as earned and reflected in the final accounting report for proper accounting and to preclude allegations that the Corps failed to disclose all cost.





REPLY TO  
ATTENTION OF

## DEPARTMENT OF THE ARMY

LOS ANGELES DISTRICT, CORPS OF ENGINEERS  
P.O. BOX 532711  
LOS ANGELES, CALIFORNIA 90053-2325



June 19, 2012

Office of  
District Counsel

John Davis  
PO Box 10152  
Marina Del Rey, CA 90295

RE: Ballona Wetlands

Dear Mr. Davis,

This letter concerns your Freedom of Information Act (FOIA) request dated May 3, 2012. Your request, assigned number FA-12-0109, is enclosed. Please use this reference number in any further correspondence regarding this request.

In your letter, you requested documents related to the Ballona Wetlands, specifically:

- 1) Any and all documents terminating the Environmental Impact Statement process undertaken by the Corps.
- 2) Any and all information regarding financial records of the aforesaid process inclusive of all expenditures of money by the Corps and all money received by the Corps for the same purpose from any source whatsoever.
- 3) Any and all information terminating the local sponsor agreement entered into for the aforesaid purpose between the Corps and the local sponsor, the Santa Monica Bay Restoration Authority.

We have conducted our search and no responsive documents exist due to the following reasons:

- 1) The Environmental Impact Statement process has not been formally terminated.
- 2) There have been no expenditures with regard to a formal termination.
- 3) The local sponsor agreement has not been terminated.

The Program Manager does not anticipate that the EIS process will be terminated in the near future.



DEPARTMENT OF THE ARMY  
OFFICE OF THE ASSISTANT SECRETARY  
CIVIL WORKS  
108 ARMY PENTAGON  
WASHINGTON DC 20310-0108

MAY 30 2012

Mr. John Davis  
P.O. Box 10152  
Marina Del Rey, California 90295

Dear Mr. Davis:

I have been asked to respond on behalf of Secretary of the Army John M. McHugh to your May 11, 2012, correspondence concerning the Marina del Rey Harbor project and the Ballona Creek, California Ecosystem Restoration feasibility study (Ballona Creek study). The Marina del Rey Harbor entrance channel is a Federal navigation project; however the side channels, docks and inner harbor facilities are not a Federal responsibility and are maintained by the Los Angeles County Department of Beaches and Harbors.

The Ballona Creek study is under development by the Los Angeles District of the Army Corps of Engineers (Corps). You asked about the status of the study, the non-federal cost sharing, and the environmental impact statement. The Ballona Creek study is an ongoing feasibility study examining restoration options for coastal wetlands and lagoons. The study and the environmental impact statement have not been finalized, and very limited federal funding is available to continue them. The non-federal sponsor, the Santa Monica Bay Restoration Commission (SMBRC), has provided its share of the study costs through in-kind services, subject to a Corps evaluation and final approval of crediting. Discussions with the SMBRC on the future of the study have been initiated.

If you would like additional details on the Marina del Rey project or the Ballona Creek study, you may wish to contact Mr. Steve Dwyer, Chief, Navigation Branch, Los Angeles District at (213) 452-3385.

Very truly yours,

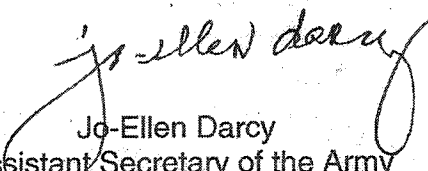
  
Jo-Ellen Darcy  
Assistant Secretary of the Army  
(Civil Works)



REPLY TO  
ATTENTION OF

## DEPARTMENT OF THE ARMY

LOS ANGELES DISTRICT, CORPS OF ENGINEERS  
P.O. BOX 532711  
LOS ANGELES, CALIFORNIA 90053-2325



June 19, 2012

Office of  
District Counsel

John Davis  
PO Box 10152  
Marina Del Rey, CA 90295

RE: Ballona Wetlands

Dear Mr. Davis,

This letter concerns your Freedom of Information Act (FOIA) request dated May 3, 2012. Your request, assigned number FA-12-0109, is enclosed. Please use this reference number in any further correspondence regarding this request.

In your letter, you requested documents related to the Ballona Wetlands, specifically:

- 1) Any and all documents terminating the Environmental Impact Statement process undertaken by the Corps.
- 2) Any and all information regarding financial records of the aforesaid process inclusive of all expenditures of money by the Corps and all money received by the Corps for the same purpose from any source whatsoever.
- 3) Any and all information terminating the local sponsor agreement entered into for the aforesaid purpose between the Corps and the local sponsor, the Santa Monica Bay Restoration Authority.

We have conducted our search and no responsive documents exist due to the following reasons:

- 1) The Environmental Impact Statement process has not been formally terminated.
- 2) There have been no expenditures with regard to a formal termination.
- 3) The local sponsor agreement has not been terminated.

The Program Manager does not anticipate that the EIS process will be terminated in the near future.

[Federal Register Volume 77, Number 143 (Wednesday, July 25, 2012)]  
[Notices] [Pages 43575-43577] From the Federal Register Online via the  
Government Printing Office [www.gpo.gov] [FR Doc No: 2012-18166] -----

-----  
DEPARTMENT OF DEFENSE Department of the Army, Corps of Engineers  
Intent To Prepare a Draft Environmental Impact Statement/ Environmental  
Impact Report for the Proposed Ballona Wetlands Restoration Project at  
Ballona Creek Within the City and County of Los Angeles, CA AGENCY:  
U.S. Army Corps of Engineers, Department of the Army, DoD. ACTION:  
Notice of intent. -----

----- SUMMARY: The U.S. Army Corps of Engineers (Corps)  
and the California Department of Fish and Game (CDFG) intend to  
jointly prepare a Draft Environmental Impact Statement/Environmental  
Impact Report (DEIS/EIR) for the proposed Ballona Wetlands Restoration  
Project. The proposed project is intended to return the daily ebb and  
flow of tidal waters, maintain freshwater circulation, and augment the  
physical and biological functions and services in the project area.  
Restoring the wetland functions and services would allow native  
wetland vegetation to be reestablished, providing important habitat  
for a variety of wildlife species. As a restored site, the Ballona  
Wetlands would play an important role to provide seasonal habitat for  
migratory birds. A restored, optimally functioning wetland would also  
benefit the adjacent marine environment and enhance the quality of  
tidal waters. DATES: Submit comments on or before September 10, 2012.

FOR FURTHER INFORMATION CONTACT: Dr. Daniel P. Swenson at (213) 452-  
3414 ([daniel.p.swenson@usace.army.mil](mailto:daniel.p.swenson@usace.army.mil)), U.S. Army Corps of Engineers,  
Los Angeles District, P.O. Box 532711, Los Angeles, CA 90053-2325.

SUPPLEMENTARY INFORMATION: The Corps intends to prepare a joint EIS/EIR  
to assess the environmental effects associated with the proposed  
project. CDFG is the state lead agency for the EIR pursuant to the  
California Environmental Quality Act (CEQA).

1. Background. The  
600-acre Ballona Wetlands Ecological Reserve is located in the western  
portion of the City of Los Angeles (partially within unincorporated  
Los Angeles County), south of Marina Del Rey and north of Playa Del  
Rey. The project site is situated approximately 1.5 miles west of  
Interstate 405 and approximately 1/4-mile east of Santa Monica Bay.  
The project site is owned by the State of California, and is bisected  
by and includes a channelized span of Ballona Creek, a component  
feature of a federal flood risk management project.

2. Project  
Purpose and Need. A substantial portion of California's historic  
coastal wetlands have been lost. Restoration of coastal wetlands is  
needed in order to increase available nursery and foraging habitat for  
wildlife and to provide recreational and educational opportunities to  
the public. The Ballona Wetlands ecosystem is one of the last  
remaining major coastal wetlands in Los Angeles County. It is  
estimated that historically the wetlands ecosystem spanned more than  
2,000 [[Page 43576]] acres in the vicinity of the site. Development  
occurring over the last century greatly reduced the Ballona wetland  
area, now estimated at approximately 600 acres. In addition, the  
wetland habitat and natural hydrological functions in the area have  
been substantially degraded. The project site provides habitat for a  
diversity of plant and wildlife species, but most on-site habitat  
exhibits relatively low physical and biological functions and  
services.

The proposed project is intended to return the daily ebb  
and flow of tidal waters, maintain freshwater circulation, and augment  
the physical and biological functions and services in the project  
area. Restoring the wetland functions and services would allow native  
wetland vegetation to be reestablished, providing important habitat

for a variety of wildlife species. As a restored site, the Ballona Wetlands would play an important role to provide seasonal habitat for migratory birds. A restored, optimally functioning wetland would also benefit the adjacent marine environment and enhance the quality of tidal waters. The proposed project would provide the community with a valuable educational resource and access to a large wetland area. The purpose of the project is to restore ecological functions of the site, in part, by enhancing tidal flow.

3. Proposed Action. CDFG is proposing a large-scale restoration of the Ballona Wetlands Ecological Reserve. The proposed project entails restoring, enhancing, and establishing native coastal wetland and upland habitats in the approximately 600-acre Ballona Wetlands Ecological Reserve. The reserve currently supports large expanses of previously filled and dredged coastal wetland and upland habitat that would be restored by increasing tidal flow throughout the project area, removing invasive species, and planting native vegetation. The main components of the proposed project are:

- Habitat restoration of estuarine wetland and upland habitats connected to a realigned Ballona Creek.
- Removal of existing Ballona Creek levees and realignment of Ballona Creek to restore a more meandering channel.
- Construction of levees along the perimeter of the project area to allow restoration of tidally influenced wetlands in the project area while providing flood risk management for Culver Boulevard and surrounding developed areas.
- Installation of water control structures, including culverts with self-regulating tide gates or similar structures, to provide a full range of tides up to an elevation acceptable for flood risk management and storm drainage, while reducing the risk of damage from storm events.
- Maintenance of existing levels of flood risk management for areas surrounding the Ballona Wetlands site.
- Provision of erosion protection as an integral part of the restoration design.
- Modification of infrastructure and utilities as necessary to implement the restoration project.
- Improving public access by realigning existing trails, creating new trails, repairing existing fences, constructing overlook platforms, and providing other visitor-oriented facilities.
- Long-term operations and management activities including inspections, repairs, clean-up, vegetation maintenance, and related activities.

The proposed project requires a permit under section 404 of the Clean Water Act (CWA) and section 10 of the Rivers and Harbors Act to conduct dredge and fill activities in waters of the United States and for work and (or) structures in or affecting navigable waters of the United States associated with restoring wetlands and associated habitat within the project site. Dredge and fill activities in waters of the United States are proposed to construct new levees, form new tidal channels, modify existing tidal channels, re-contour areas to enhance tidal flow, and to create elevations conducive to establishing wetland habitat. Preliminary conservative estimates indicate the project would result in a balanced total of 1,782,000 cubic yards of excavation and 1,782,000 cubic yards of fill placement, not all of which would affect jurisdictional areas. Based on these preliminary estimates, the volumes and areas of fill are estimated as follows: Permanent discharge of fill within 43.5 acres of non-wetland waters of the U.S. (435,000 cubic yards) and within 65 acres of wetland waters of the U.S. (600,000 cubic yards), as well as temporary discharge of fill within 3.5 acres of non-wetland waters of the U.S. (30,000 cubic yards) and within 0.3 acres of wetland waters of the U.S. (structural fill). The project will also require a permit from the Corps to the Los Angeles County Department of Public Works, as the non-Federal sponsor of the Los Angeles County

Drainage Area (LACDA) project, pursuant to 33 U.S.C. section 408 (408 permit). A section 408 permit is required to alter/modify a completed Corps project. The Ballona Creek levees were constructed by the Corps in the 1930s as part of LACDA. This project proposes to remove levees, construct a larger levee reach around the perimeter of the proposed side, reconfigure the existing concrete-lined Ballona Creek flood-control channel and realign the creek. A permit for modification/alteration of this magnitude would require Corps Headquarters approval.

4. Alternatives Considered. The feasibility of several alternatives is being considered and will be addressed in the DEIS/EIR. The No Federal Action/No Project Alternative, as required by NEPA and CEQA, would maintain the status quo and would include no improvements or discharges of fill material in waters of the United States or work or structures in or affecting navigable waters of the United States. Other alternatives that may be considered include restoring smaller portions of the 600-acre site, alternative designs that would provide differing amounts of various habitats types, and alternative designs for enhancing tidal flow. Additional alternatives may be developed during scoping and will also be considered in the DEIS/EIR.

5. Scoping Process.

a. Affected federal, state and local resource agencies, Native American groups and concerned interest groups/individuals are encouraged to participate in the scoping process. Public participation is critical in defining the scope of analysis in the DEIS/EIR, identifying significant environmental issues in the DEIS/EIR, providing useful information such as published and unpublished data, and knowledge of relevant issues and recommending mitigation measures to offset potential impacts from proposed actions.

b. Potential impacts associated with the proposed project will be fully evaluated. Potential significant issues to be addressed in the DEIS/EIR include aesthetics, air quality and greenhouse gas emissions, biological resources, cultural resources, geology and soils, hazards and hazardous materials, hydrology and water quality, land use and planning, noise, public services, recreation, sea-level rise, traffic, flood control, and utilities. Additional issues may be identified during the scoping process.

c. Individuals and agencies may offer information or data relevant to the environmental or socioeconomic impacts of the proposed project by submitting comments, suggestions, and requests to be placed on the mailing list for announcements to (see FOR FURTHER INFORMATION CONTACT) or the following email address:  
Daniel.p.swenson@usace.army.mil. [[Page 43577]]

d. The Corps anticipates formally consulting with the U.S. Fish and Wildlife Service under Section 7 of the Endangered Species Act, the National Marine Fisheries Service under Section 305(b)(2) of the Magnuson-Stevens Fishery Conservation and Management Act (MSA), and with the State Historic Preservation Officer under Section 106 of the National Historic Preservation Act. The CDFG, as the project proponent, will need to obtain a CWA section 401 water quality certification or waiver and a consistency certification from the California Coastal Commission in accordance with the Coastal Zone Management Act.

6. Scoping Meeting Date, Time, and Location. A public scoping meeting to receive input on the scope of the DEIS/EIR will be conducted on August 16, 2012, from 4:00-7:00 p.m. at the Fiji Gateway entrance to the Ballona Wetlands (13720 Fiji Way, Marina del Rey, CA 90292, across from Fisherman's Village and Los Angeles County Department of Beaches and Harbors).

7. Availability of the DEIS/EIR. The DEIS/EIR is expected to be published and circulated in late 2012. A public hearing will be held after its publication to field comments on the document. David

J. Castanon, Chief, Regulatory Division, Corps of Engineers. [FR Doc.  
2012-18166 Filed 7-24-12; 8:45 am] BILLING CODE 3720-58-P

deposit rate will be 5.53 percent; (2) for subject merchandise exported by Golden Dragon but not manufactured by Golden Dragon, the cash deposit rate will be the all others rate (*i.e.*, 26.03 percent); (3) for subject merchandise manufactured by Golden Dragon but exported by any party other than Golden Dragon, the cash deposit rate will be the all others rate. These requirements, when imposed, shall remain in effect until further notice.

Further, effective upon publication of the final results, we intend to instruct CBP that importers may no longer post a bond or other security in lieu of a cash deposit on imports of seamless refined copper pipe and tube from Mexico, manufactured and exported by Golden Dragon. These cash deposit requirements, when imposed, shall remain in effect until further notice.

**Notifications to Interested Parties**

This notice also serves as a final reminder to importers of their responsibility under 19 CFR 351.402(f)(2) to file a certificate regarding the reimbursement of antidumping duties prior to liquidation of the relevant entries during this POR. Failure to comply with this requirement could result in the Department's presumption that reimbursement of antidumping duties has occurred and the subsequent assessment of doubled antidumping duties.

In accordance with 19 CFR 351.305(a)(3), this notice also serves as a reminder to parties subject to administrative protective order ("APO") of their responsibility concerning the return or destruction of proprietary information disclosed under the APO, which continues to govern business proprietary information in this segment of the proceeding. Timely written notification of the return/destruction of APO materials or conversion to judicial protective order is hereby requested. Failure to comply with the regulations and terms of an APO is a violation subject to sanction.

We are issuing and publishing this new shipper review and notice in accordance with sections 751(a)(1) and 777(i) of the Act.

Dated: September 20, 2012.

**Paul Piquado,**  
*Assistant Secretary for Import Administration.*

**Appendix I—Issues and Decision Memorandum**

Comment 1: Date of Sale  
 Comment 2: Adjustment to U.S. Price

**Comment 3: Entitlement to New Shipper Review**

[FR Doc. 2012-23686 Filed 9-25-12; 8:45 am]

**BILLING CODE 3510-DS-P**

**CONSUMER PRODUCT SAFETY COMMISSION**

[CPSC Docket No. 12-1]

**Telephonic Prehearing Conference Cancellation**

**AGENCY:** U.S. Consumer Product Safety Commission.

**ACTION:** Cancellation of Telephonic prehearing conference.

**SUMMARY:** Cancellation of Telephonic prehearing conference on September 25, 2012, in the matter of Maxfield and Oberton Holdings, LLC, CPSC Docket 12-1.

**FOR FURTHER INFORMATION CONTACT:** Katy J.L. Duke, Esq., U.S. Coast Guard ALJ Program, 504/671-2213.

Dated: September 21, 2012.

**Todd A. Stevenson,**  
*Secretary.*

[FR Doc. 2012-23664 Filed 9-25-12; 8:45 am]

**BILLING CODE 6355-01-P**

**DEPARTMENT OF DEFENSE**

**Department of the Army, Corps of Engineers**

**Withdrawal of Intent To Prepare a Draft Environmental Impact Statement/ Environmental Impact Report for the Ballona Creek Ecosystem Restoration Feasibility Study, Los Angeles County, CA**

**AGENCY:** Department of the Army, U.S. Army Corps of Engineers, DoD.

**ACTION:** Notice of intent.

**SUMMARY:** The Los Angeles District of the U.S. Army Corps of Engineers (Corps) published a Notice of Intent to Prepare a Draft Environmental Impact Statement/Environmental Impact Report (EIS/EIR) for the Ballona Creek Ecosystem Restoration Feasibility Study in the *Federal Register* on September 20, 2005 (70 FR 55116). The study's purpose is to evaluate structural and non-structural means of restoring diminished ecosystem functions and services within the lower reach of Ballona Creek including coastal wetlands. Santa Monica Bay Restoration Commission (SMBRC) is the local sponsor for the cost-shared study.

On September 29, 2005, a public scoping meeting was held pursuant to

requirements of the National Environmental Policy Act and Engineer Regulations 1105-2-100. Baseline conditions portions of the EIS/EIR have been completed as of January, 2012. On July 17, 2012, the SMBRC requested the Corps terminate the study. Therefore, the Corps is withdrawing the Notice of Intent to Prepare a draft EIS/EIR.

**FOR FURTHER INFORMATION CONTACT:** Ms. Jodi Clifford, Chief, Environmental Resources Branch, Mailing Address: Ms. Jodi Clifford, Chief, Environmental Resources Branch, Corps of Engineers, Los Angeles District, CESPL-PD-R, 915 Wilshire Boulevard, Los Angeles, CA 90017. Telephone: (213) 452-3840. Email: *Jodi.L.Clifford@usace.army.mil*.

**SUPPLEMENTARY INFORMATION:** The Corps is no longer pursuing restoration within Ballona Creek as a cost-shared study within its Civil Works program. Although SMBRC requested the Corps terminate the feasibility study, SMBRC, acting on behalf of the California Department of Fish and Game, is moving forward with plans for ecosystem restoration within Ballona Creek. SMBRC must obtain permissions from the Corps to proceed with implementation of its restoration proposals. Therefore, the Corps is initiating an EIS pursuant to its authorities under Section 404 of the Clean Water Act, Section 10 of the 1899 Rivers and Harbors Act, and Title 33, U.S. Code, Section 408 for a project to be planned and carried out by SMBRC. To that end, the Corps published a Notice of Intent to Prepare an EIS in the *Federal Register* on July 25, 2012 (77 FR 43575). A scoping meeting was held on August 16, 2012. All technical studies and reports prepared under the Civil Works feasibility study authority will be utilized to the maximum practical extent in support of the EIS/EIR process now underway.

Dated: September 12, 2012.

**R. Mark Toy,**  
*Colonel, U.S. Army Commander and District Engineer.*

[FR Doc. 2012-23669 Filed 9-25-12; 8:45 am]

**BILLING CODE 3720-58-P**

**DEPARTMENT OF DEFENSE**

**Corps of Engineers, Department of the Army**

**Notice of Intent To Prepare a Draft Environmental Impact Statement for a Proposed Aquatic Ecosystem Restoration Project for the Quiver River, MS**

**AGENCY:** Department of Defense, U.S. Army Corps of Engineers, DoD.





SECRETARY OF THE ARMY  
WASHINGTON

MAY 17 2012

Mr. John Davis  
Post Office Box 10152  
Marina del Rey, California 90295

Dear Mr. Davis:

Thank you for your May 11, 2012 communication concerning the status of preparation of an Environmental Impact Statement for the Playa del Rey Inlet and Basin.

I have asked the Assistant Secretary of the Army for Civil Works, who has responsibility in this area, to look into this project and provide you an appropriate update on its status.

Thank you for bringing this matter to my attention and for supporting our Army.

Sincerely,

A handwritten signature in black ink, which appears to read "John M. McHugh", is written over a printed name. The signature is stylized and includes a large, sweeping flourish at the end.

John M. McHugh

**EXHIBIT 7**

2010 Integrated Report | Map | Admin. Record | Data Download | Past Reports | Contact Us

2010 INTEGRATED REPORT — ALL ASSESSED WATERS

Zoom to county:   Show county

Zoom to Regional Board:   Show Regional Board

Zoom to water body: (Filter: All)

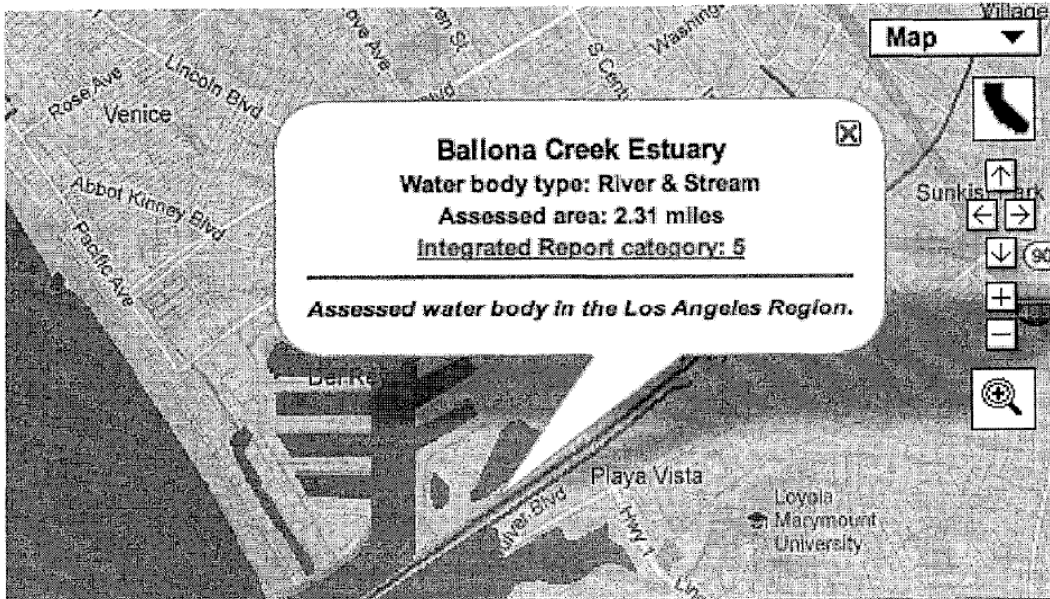

Show all assessed waters

Show only impaired ("303(d)-listed") waters

**Show water bodies by pollutant:**

Pollutant category:

Pollutant:

Pollutant assessments for Ballona Creek Estuary

| Pollutants                                                                                                                                                                      | Listing Decision                                             | Detailed Report      | Potential Sources             | Schedule                  |
|---------------------------------------------------------------------------------------------------------------------------------------------------------------------------------|--------------------------------------------------------------|----------------------|-------------------------------|---------------------------|
| Antimony   Arsenic   Benzo(a)pyrene (3,4-Benzopyrene -7-d)   Benzo[a]anthracene   Chromium (total)   Chrysene (C1-C4)   Dibenz[a,h]anthracene   Mercury   Phenanthrene   Pyrene | Do Not List on 303(d) list (TMDL required list)              | <a href="#">7584</a> |                               |                           |
| Cadmium                                                                                                                                                                         | List on 303(d) list (being addressed by USEPA approved TMDL) | <a href="#">6038</a> | Source Unknown                | USEPA TMDL approval: 2005 |
| Chlordane (tissue & sediment)                                                                                                                                                   | List on 303(d) list (being addressed by USEPA approved TMDL) | <a href="#">4822</a> | Nonpoint Source, Point Source | USEPA TMDL approval: 2005 |
| Coliform Bacteria                                                                                                                                                               | List on 303(d) list (being addressed by USEPA approved TMDL) | <a href="#">6025</a> | Nonpoint Source, Point Source | USEPA TMDL approval: 2007 |

2010 Integrated Report

Map

Admin. Record

Data Download

Past Reports

Contact Us

2010 INTEGRATED REPORT — ALL ASSESSED WATERS

Zoom to county:

All

Zoom to Regional Board:

All

Map Help

Show county

Show Regional Board

Zoom to water body: (Filter: All)

Filter list by:

Reset list

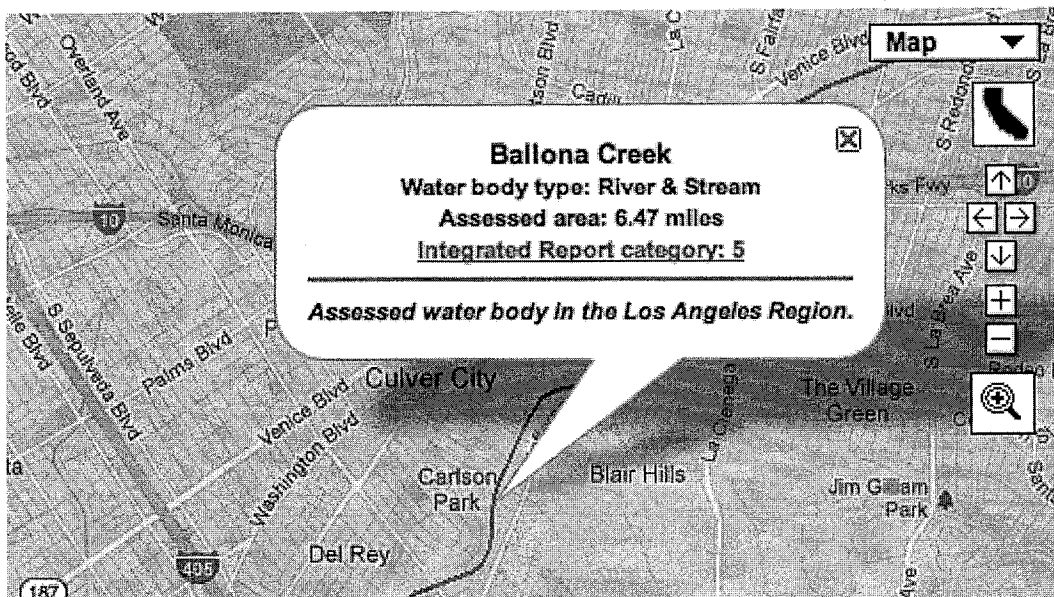

- Show all assessed waters
- Show only impaired ("303(d)-listed") waters

Show water bodies by pollutant:

Pollutant category:

All

All

Pollutant:

All

All

Pollutant assessments for Ballona Creek

Close

| Pollutants         | Listing Decision                                                                      | Detailed Report      | Potential Sources             | Schedule                   |
|--------------------|---------------------------------------------------------------------------------------|----------------------|-------------------------------|----------------------------|
|                    | <i>Comments</i>                                                                       |                      |                               |                            |
| Ammonia            | Do Not List on 303(d) list (TMDL required list)                                       | <a href="#">4468</a> | n/a                           |                            |
| Cadmium (sediment) | Do Not Delist from 303(d) list (TMDL required list)                                   | <a href="#">4880</a> | Nonpoint Source, Point Source | Est. TMDL completion: 2005 |
|                    | <i>A USEPA-approved TMDL has made a finding of non-impairment for this pollutant.</i> |                      |                               |                            |
| ChemA              | Delist from 303(d) list (TMDL required list)                                          | <a href="#">4358</a> | n/a                           |                            |
| Chlordane          | Delist from 303(d) list (TMDL required list)                                          | <a href="#">4881</a> | n/a                           |                            |
| Coliform Bacteria  | List on 303(d) list (being addressed by USEPA approved TMDL)                          | <a href="#">6024</a> | Nonpoint Source, Point Source | USEPA TMDL approval: 2007  |

2010 Integrated Report

Map

Admin. Record

Data Download

Past Reports

Contact Us

**2010 INTEGRATED REPORT — ALL ASSESSED WATERS**

Zoom to county:

All

Show county

Zoom to Regional Board:

All

Show Regional Board

Map Help

Zoom to water body: (Filter: All)

Filter list by:

Reset list

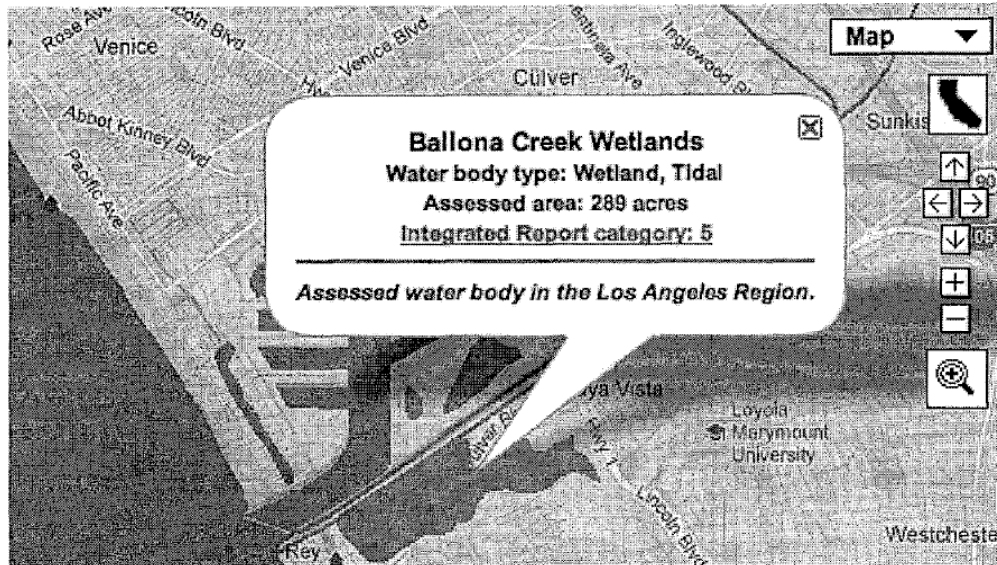

- Show all assessed waters
- Show only impaired ("303(d)-listed") waters

Show water bodies by pollutant:

Pollutant category:

All

All

Pollutant:

All

All

**Pollutant assessments for Ballona Creek Wetlands**

Close

| Pollutants             | Listing Decision                                             | Detailed Report      | Potential Sources | Schedule                   |
|------------------------|--------------------------------------------------------------|----------------------|-------------------|----------------------------|
|                        | <i>Comments</i>                                              |                      |                   |                            |
| Exotic Vegetation      | List on 303(d) list (TMDL required list)                     | <a href="#">7481</a> | Nonpoint Source   | Est. TMDL completion: 2019 |
| Habitat alterations    | List on 303(d) list (TMDL required list)                     | <a href="#">7484</a> | Nonpoint Source   | Est. TMDL completion: 2019 |
| Hydromodification      | List on 303(d) list (TMDL required list)                     | <a href="#">7487</a> | Nonpoint Source   | Est. TMDL completion: 2019 |
| Reduced Tidal Flushing | List on 303(d) list (TMDL required list)                     | <a href="#">7486</a> | Nonpoint Source   | Est. TMDL completion: 2019 |
| Trash                  | List on 303(d) list (being addressed by USEPA approved TMDL) | <a href="#">6155</a> | Nonpoint Source   | USEPA TMDL approval: 2019  |

2010 Integrated Report

Map

Admin. Record

Data Download

Past Reports

Contact Us

2010 INTEGRATED REPORT — ALL ASSESSED WATERS

Zoom to county:

All

Show county

Zoom to Regional Board:

All

Show Regional Board

Map Help

Zoom to water body: (Filter: All)

Filter list by:

Reset list

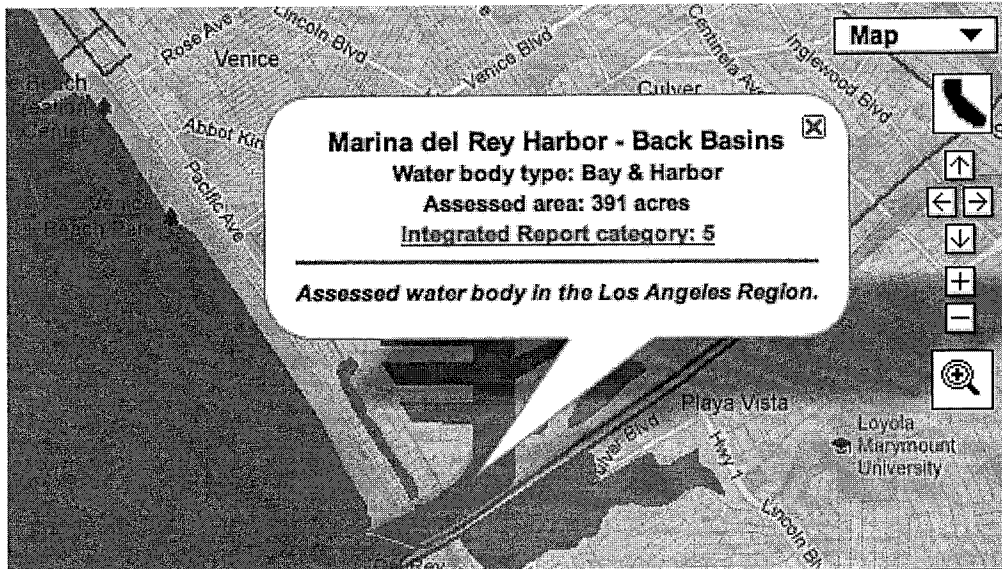

- Show all assessed waters
- Show only impaired ("303(d)-listed") waters

Show water bodies by pollutant:

Pollutant category:

All

All

Pollutant:

All

All

Pollutant assessments for Marina del Rey Harbor - Back Basins

Close

| Pollutants                    | Listing Decision                                                                      | Detailed Report      | Potential Sources | Schedule                   |
|-------------------------------|---------------------------------------------------------------------------------------|----------------------|-------------------|----------------------------|
|                               | <i>Comments</i>                                                                       |                      |                   |                            |
| Chlordane (tissue & sediment) | List on 303(d) list (being addressed by USEPA approved TMDL)                          | <a href="#">6021</a> | Nonpoint Source   | USEPA TMDL approval: 2005  |
| Copper (sediment)             | List on 303(d) list (being addressed by USEPA approved TMDL)                          | <a href="#">6363</a> | Nonpoint Source   | USEPA TMDL approval: 2006  |
| DDT (tissue)                  | Do Not Delist from 303(d) list (TMDL required list)                                   | <a href="#">7328</a> | Nonpoint Source   | Est. TMDL completion: 2005 |
|                               | <i>A USEPA-approved TMDL has made a finding of non-impairment for this pollutant.</i> |                      |                   |                            |
| Dieldrin (tissue)             | Do Not Delist from 303(d) list (TMDL required list)                                   | <a href="#">6816</a> | Nonpoint Source   | Est. TMDL completion: 2005 |
|                               | <i>A USEPA-approved TMDL has made a finding of non-impairment for this pollutant.</i> |                      |                   |                            |
| Fish Consumption Advisory     | List on 303(d) list (being addressed by USEPA approved TMDL)                          | <a href="#">6022</a> | Nonpoint Source   | USEPA TMDL approval: 2005  |

EXHIBIT 8

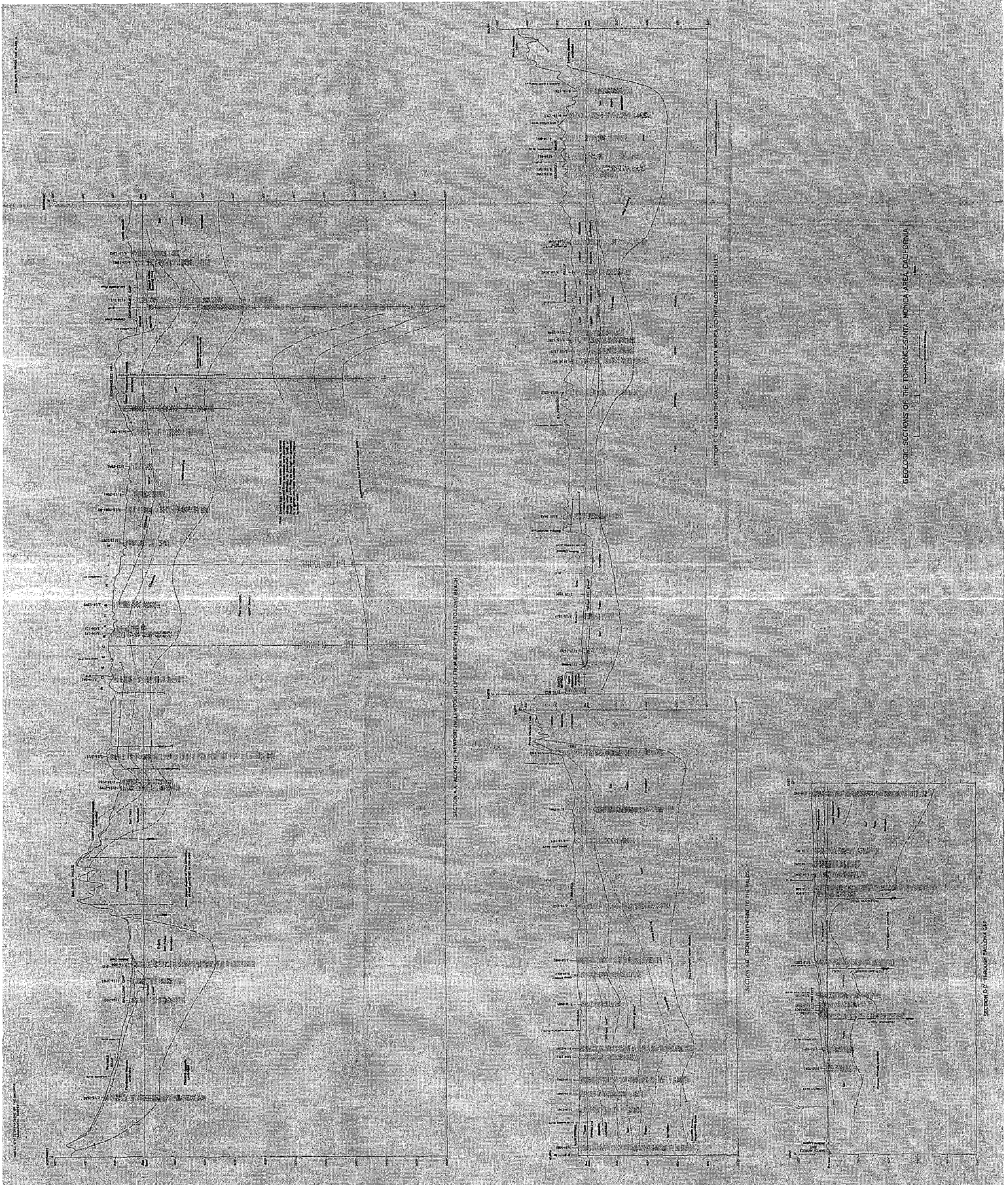



---

# Geology, Hydrology, and Chemical Character of Ground Waters in the Torrance-Santa Monica Area, California

By J. F. POLAND, A. A. GARRETT, and ALLEN SINNOTT

---

GEOLOGICAL SURVEY WATER-SUPPLY PAPER 1461

*Prepared in cooperation with the Los Angeles County Flood Control District, in collaboration with the cities of Inglewood, Redondo Beach, Manhattan Beach, El Segundo, Hawthorne, Culver City, Gardena, Hermosa Beach, and Palos Verdes Estates, and with the West Basin Water Association*



---

UNITED STATES GOVERNMENT PRINTING OFFICE, WASHINGTON : 1959

UNITED STATES DEPARTMENT OF THE INTERIOR

FRED A. SEATON, *Secretary*

GEOLOGICAL SURVEY

Thomas B. Nolan, *Director*

The U. S. Geological Survey Library has cataloged this publication as follows:

**Poland, Joseph Fairfield, 1908-**

Geology, hydrology, and chemical character of ground waters in the Torrance-Santa Monica area, California, by J. F. Poland, A. A. Garrett, and Allen Sinnott. Washington, U. S. Govt. Print. Off., 1959.

xi, 425 p. maps (2 col.) diags., tables. 25 cm. (U. S. Geological Survey, Water-supply paper 1461)

Part of illustrative matter folded in pocket.

Prepared in cooperation with the Los Angeles County Flood Control District, in collaboration with nine cities and with the West Basin Water Association.

"References cited"; p. 270-273.

1. Water, Underground—California—Torrance-Santa Monica area.
2. Water-supply—California—Torrance-Santa Monica area. I. Title: Torrance-Santa Monica area, California. (Series)  
TC801.U2 no. 1461 551.49 G S 58-222  
Copy 2. GB1025.C2P59

---

For sale by the Superintendent of Documents, U. S. Government Printing Office  
Washington 25, D. C.

## CONTENTS

|                                                                  | Page |
|------------------------------------------------------------------|------|
| Abstract.....                                                    | 1    |
| Introduction.....                                                | 5    |
| Location and general features of the area.....                   | 5    |
| Scope of the investigation and of this report.....               | 6    |
| Other investigations.....                                        | 9    |
| Acknowledgments.....                                             | 10   |
| Numbers applied to wells by the Geological Survey.....           | 11   |
| Subdivisions of the west basin with respect to ground water..... | 12   |
| Climate.....                                                     | 13   |
| Physiography.....                                                | 15   |
| General features.....                                            | 15   |
| Bordering highlands and alluvial aprons.....                     | 16   |
| Newport-Inglewood belt of hills and plains.....                  | 16   |
| Hills.....                                                       | 16   |
| Related plains.....                                              | 17   |
| Gaps.....                                                        | 18   |
| El Segundo sandhills.....                                        | 19   |
| Downey plain.....                                                | 20   |
| Drainage.....                                                    | 20   |
| Geologic formations and their water-bearing character.....       | 22   |
| General features.....                                            | 22   |
| Quaternary system.....                                           | 26   |
| Recent series.....                                               | 26   |
| Definition and general features.....                             | 26   |
| Upper division.....                                              | 27   |
| Lower division.....                                              | 28   |
| Water-bearing character.....                                     | 31   |
| Pleistocene series.....                                          | 32   |
| General features.....                                            | 32   |
| Terrace cover and Palos Verdes sand.....                         | 32   |
| Unnamed upper Pleistocene deposits.....                          | 35   |
| Definition and extent.....                                       | 35   |
| Physical character and thickness.....                            | 36   |
| Stratigraphic relations.....                                     | 39   |
| San Pedro formation.....                                         | 39   |
| Definition.....                                                  | 39   |
| Representative exposed sections.....                             | 41   |
| Faunal data from outcrops and wells.....                         | 42   |
| Thickness.....                                                   | 44   |
| Physical character and water-bearing properties.....             | 45   |
| Stratigraphic relations.....                                     | 56   |

III

|                                                                 | Page |
|-----------------------------------------------------------------|------|
| Geologic formations and their water-bearing character—Continued |      |
| Tertiary system.....                                            | 57   |
| Pliocene series.....                                            | 57   |
| General features.....                                           | 57   |
| Pico formation, upper division.....                             | 57   |
| Physical character and thickness.....                           | 57   |
| Stratigraphic relations.....                                    | 59   |
| Water-bearing character.....                                    | 60   |
| Pico formation, middle and lower divisions.....                 | 64   |
| Older rocks of Tertiary age.....                                | 65   |
| Pre-Tertiary rocks.....                                         | 65   |
| Geologic structure.....                                         | 66   |
| Regional features.....                                          | 66   |
| Newport-Inglewood uplift.....                                   | 67   |
| General features.....                                           | 67   |
| Folds.....                                                      | 68   |
| Faults.....                                                     | 69   |
| Cherry-Hill fault.....                                          | 69   |
| Faults in the Dominguez Hill area.....                          | 70   |
| Avalon-Compton fault.....                                       | 71   |
| Faulting in the central part of the Rosecrans Hills.....        | 71   |
| Potrero fault and associated minor faults.....                  | 72   |
| Inglewood fault and associated minor faults.....                | 74   |
| Faults in Ballona Gap.....                                      | 76   |
| Ground-water hydrology.....                                     | 78   |
| Regional ground-water conditions.....                           | 78   |
| Ground water in the west basin.....                             | 82   |
| Semiperched water body.....                                     | 82   |
| Occurrence.....                                                 | 82   |
| Utility.....                                                    | 84   |
| Decline of water level.....                                     | 84   |
| Principal water body.....                                       | 85   |
| Occurrence.....                                                 | 85   |
| Extent and thickness.....                                       | 85   |
| Confined and water-table conditions.....                        | 87   |
| Source and movement.....                                        | 88   |
| Method of investigation.....                                    | 88   |
| Movement in the Torrance-Inglewood subarea.....                 | 90   |
| Movement in the Culver City subarea.....                        | 94   |
| Withdrawal of ground water.....                                 | 99   |
| History of development.....                                     | 99   |
| Pumpage from municipal well fields.....                         | 100  |
| Withdrawal from the Torrance-Inglewood subarea, 1931-45.....    | 102  |
| Methods of evaluating withdrawal.....                           | 102  |
| Estimate of total pumpage.....                                  | 105  |
| Withdrawal from the Culver City subarea.....                    | 106  |
| Withdrawal inland from the west basin.....                      | 108  |
| Distribution of draft as of 1945.....                           | 109  |
| Principal sources of ground water.....                          | 110  |
| Sources in the Torrance-Inglewood subarea.....                  | 110  |
| Sources in the Culver City subarea.....                         | 111  |
| Sources inland from the west basin.....                         | 111  |

CONTENTS

v

|                                                                                                     | Page |
|-----------------------------------------------------------------------------------------------------|------|
| <b>Ground-water hydrology—Continued</b>                                                             |      |
| <b>Water-level fluctuations</b> .....                                                               | 112  |
| Scope and utility of the records.....                                                               | 112  |
| Fluctuations in the Torrance-Inglewood subarea.....                                                 | 114  |
| Difference in head developed between the several aquifers..                                         | 114  |
| Vicinity of Dominguez Gap.....                                                                      | 114  |
| Gardena area.....                                                                                   | 120  |
| Vicinity of Inglewood.....                                                                          | 122  |
| Fluctuations and change in head in the Silverado water-bearing zone.....                            | 122  |
| Area south of Redondo Beach Boulevard.....                                                          | 122  |
| Area between Gardena and the Ballona escarpment...                                                  | 124  |
| Fluctuations in the Culver City subarea.....                                                        | 126  |
| Coastal area.....                                                                                   | 127  |
| Charnock subbasin.....                                                                              | 127  |
| Crestal subbasin.....                                                                               | 129  |
| Fluctuations induced by pumping.....                                                                | 130  |
| <b>Hydrologic evidence relating to boundaries of the west basin</b> .....                           | 133  |
| Water levels across the barrier features of the Newport-Inglewood uplift.....                       | 133  |
| Dominguez Hill to the Baldwin Hills.....                                                            | 134  |
| Ballona Gap.....                                                                                    | 136  |
| Pumping test at Inglewood well field.....                                                           | 137  |
| Pumping test near Wilmington.....                                                                   | 139  |
| <b>Replenishment to the west basin</b> .....                                                        | 142  |
| Sources and general features.....                                                                   | 142  |
| Early conditions.....                                                                               | 142  |
| Conditions developed by water-level decline.....                                                    | 142  |
| Ocean-water replenishment.....                                                                      | 142  |
| Water released by compaction.....                                                                   | 142  |
| Replenishment to the Torrance-Inglewood subarea.....                                                | 146  |
| Magnitude of replenishment in 1903-4.....                                                           | 146  |
| Magnitude of replenishment in 1933-41.....                                                          | 148  |
| Estimate by relating pumpage and change in storage...                                               | 149  |
| Contribution from the ocean.....                                                                    | 153  |
| Underflow across the Newport-Inglewood uplift.....                                                  | 155  |
| Dewatering along the uplift crest.....                                                              | 156  |
| Change in differential head across the barrier features..                                           | 157  |
| Methods of estimating underflow.....                                                                | 159  |
| Factors affecting current and future replenishment.....                                             | 161  |
| Replenishment to the Culver City subarea.....                                                       | 162  |
| <b>Chemical character of native and contaminated ground waters</b> .....                            | 164  |
| General nature of the chemical problems.....                                                        | 164  |
| Scope and sources of analytical data.....                                                           | 165  |
| Character and distribution of native waters in the deposits commonly penetrated by water wells..... | 166  |
| Range in chemical character of water from wells.....                                                | 166  |
| Zones of water quality.....                                                                         | 169  |

| Chemical character of native and contaminated ground waters—Continued                                    |      |
|----------------------------------------------------------------------------------------------------------|------|
| Character and distribution of native waters in the deposits commonly penetrated by water wells—Continued |      |
|                                                                                                          | Page |
| Chemical character of the waters.....                                                                    | 174  |
| Unconfined waters.....                                                                                   | 174  |
| Confined waters.....                                                                                     | 176  |
| Waters in range 1 (Gaspur water-bearing zone and "50-foot gravel").....                                  | 176  |
| Waters in range 3 (unnamed upper Pleistocene deposits).....                                              | 177  |
| Waters in range 5 (upper part of the San Pedro formation).....                                           | 178  |
| Waters in range 6 (middle and lower parts of the San Pedro formation).....                               | 179  |
| Waters of the undifferentiated Pleistocene deposits.....                                                 | 182  |
| Waters in range 7 (upper division of the Pico formation).....                                            | 183  |
| Waters at the Centinela Park well field of the city of Inglewood.....                                    | 184  |
| Potential contaminants of fresh-water bodies in the Torrance-Santa Monica area.....                      | 184  |
| Exterior contaminants.....                                                                               | 185  |
| Ocean water.....                                                                                         | 185  |
| Industrial wastes.....                                                                                   | 186  |
| Oil-field brines.....                                                                                    | 188  |
| Interior contaminants.....                                                                               | 192  |
| Contamination of the native fresh waters.....                                                            | 192  |
| General extent of water-quality depreciation.....                                                        | 192  |
| Modifications in chemical character of contaminated waters.....                                          | 193  |
| Contamination in Ballona Gap.....                                                                        | 194  |
| Summary of native water quality.....                                                                     | 194  |
| General features and extent of contamination.....                                                        | 197  |
| Contamination near the coast.....                                                                        | 198  |
| Chemical features of contamination.....                                                                  | 199  |
| Contamination on the west flank of Baldwin Hills.....                                                    | 206  |
| Contamination on the north flank of Baldwin Hills.....                                                   | 207  |
| Wells at the Sentney plant of the Southern California Water Co.....                                      | 210  |
| Rate of advance of the contamination front.....                                                          | 213  |
| Contamination from Playa del Rey to Redondo Beach.....                                                   | 213  |
| Well field at Playa del Rey.....                                                                         | 215  |
| Well field of the city of El Segundo.....                                                                | 217  |
| Well field of the Standard Oil Co. and the General Chemical Co. at El Segundo.....                       | 224  |
| Well field of the city of Manhattan Beach.....                                                           | 236  |
| Wells in and near Redondo Beach.....                                                                     | 243  |
| Rate of inland advance of the contamination front.....                                                   | 250  |
| Inferior waters of the Gardena area.....                                                                 | 253  |
| Waters from the unconfined body.....                                                                     | 253  |
| Waters from the unnamed upper Pleistocene deposits.....                                                  | 254  |
| Contamination in Dominguez Gap.....                                                                      | 255  |
| Summary of native-water occurrence and quality.....                                                      | 257  |
| Review of contamination.....                                                                             | 258  |

CONTENTS

VII

|                                                                          | Page |
|--------------------------------------------------------------------------|------|
| Control of saline encroachment.....                                      | 261  |
| Need for restraint of encroachment.....                                  | 261  |
| Methods of control.....                                                  | 262  |
| General aspects.....                                                     | 262  |
| Control adjacent to saline fronts.....                                   | 263  |
| Construction of artificial subsurface dikes.....                         | 263  |
| Development of a water-level trough coastward from the saline front..... | 264  |
| Maintenance of fresh-water head above sea level.....                     | 264  |
| Basin-wide raising of water levels.....                                  | 267  |
| Well records.....                                                        | 268  |
| References cited.....                                                    | 270  |
| Index.....                                                               | 421  |

ILLUSTRATIONS

[Plates in map case]

- | PLATE |                                                                                                                                                                                                                     |
|-------|---------------------------------------------------------------------------------------------------------------------------------------------------------------------------------------------------------------------|
| 1.    | Generalized geologic map of the coastal plain and contiguous areas in Los Angeles and Orange Counties, Calif.                                                                                                       |
| 2.    | Geologic map of the Torrance-Santa Monica area, California.                                                                                                                                                         |
| 3.    | Geologic sections of the Torrance-Santa Monica area.                                                                                                                                                                |
| 4.    | Geologic section <i>E-E'</i> , from Manhattan Beach to Huntington Park; also water-level profiles of 1903-45.                                                                                                       |
| 5.    | Geologic section <i>F-F'</i> , from Redondo Beach to Long Beach; also water-level profiles of 1903-45.                                                                                                              |
| 6.    | Geologic section <i>G-G'</i> , from Terminal Island through Dominguez Gap.                                                                                                                                          |
| 7.    | Diagrammatic correlation of stratigraphic columns in the Torrance-Santa Monica area.                                                                                                                                |
| 8.    | Map showing generalized contours on the base of the principal fresh-water body in the Torrance-Santa Monica area; also extent of the Gaspar water-bearing zone and the "50-foot gravel."                            |
| 9.    | Map of the Torrance-Santa Monica area showing water-level contours for March 1933; also for 1903-4 in the southern part of the area.                                                                                |
| 10.   | Map showing rise or fall of water levels in the Torrance-Inglewood subarea from March 1933 to April 1941.                                                                                                           |
| 11.   | Map of the Torrance-Santa Monica area showing water-level contours for April 1941.                                                                                                                                  |
| 12.   | Map of the Torrance-Santa Monica area showing water-level contours for November 1945; also distribution of pumpage for public supply or industrial use in 1945.                                                     |
| 13.   | Hydrographs for selected wells in the central part of the west basin and on Rosecrans Hills.                                                                                                                        |
| 14.   | Hydrographs for selected wells in Ballona Gap.                                                                                                                                                                      |
| 15.   | Section along the crest of the Newport-Inglewood uplift from Baldwin Hills to Long Beach, showing the generalized position of water-bearing deposits; also water-level profiles indicating magnitude of dewatering. |

## VIII

## CONTENTS

|               |                                                                                                                                                                                     |             |
|---------------|-------------------------------------------------------------------------------------------------------------------------------------------------------------------------------------|-------------|
| <b>PLATE</b>  | 16. Map of the Torrance-Santa Monica area showing districts in the coastal zone in which one or more of the ground-water bodies contained more than 100 ppm of chloride in 1945-46. |             |
|               | 17. Map of the Torrance-Santa Monica area showing location of wells and certain other points at which waters have been sampled for chemical analyses.                               |             |
|               | 18. Map of the Torrance-Santa Monica area showing sources of representative native waters from the shallow unconfined water body.                                                   |             |
|               | 19. Map of the Torrance-Santa Monica area showing sources of representative native waters from the Silverado water-bearing zone and from the San Pedro and Pico formations.         |             |
|               | 20. Chloride content of waters from selected wells in Ballona Gap between Centinela Boulevard and the coast.                                                                        |             |
|               |                                                                                                                                                                                     | <b>Page</b> |
| <b>FIGURE</b> | 1. Map of California showing area covered by this report and that covered by plate 1.....                                                                                           | 5           |
|               | 2. Map showing extent and thickness of the Silverado water-bearing zone within the Torrance-Santa Monica area.....                                                                  | 49          |
|               | 3. Estimated withdrawals of ground water from the Torrance-Inglewood subarea, 1931-45.....                                                                                          | 105         |
|               | 4. Hydrographs of longest record for wells in and near the west basin.....                                                                                                          | 115         |
|               | 5. Hydrographs for selected wells in the southern part of the west basin.....                                                                                                       | 116         |
|               | 6. Graphs showing fluctuations of water level in wells 4/13-33D1 and 4/14-13F1 induced by pumping of distant wells.                                                                 | 131         |
|               | 7. Map of wells, and graphs showing fluctuations of water level in well 2/14-27D1 in Inglewood as related to pumping of nearby wells on opposite sides of Potrero fault.....        | 138         |
|               | 8. Map of wells, and graph showing results of pumping tests to determine presence or absence of barrier features near Bixby Slough.....                                             | 140         |
|               | 9. Chemical character of 375 water samples from 338 wells in the Torrance-Santa Monica area, 1929-46.....                                                                           | 168         |
|               | 10. Chemical character of selected native waters in Ballona Gap compared to waters just south of the Ballona escarpment.....                                                        | 195         |
|               | 11. Chemical character of native and contaminated waters in the coastal part of Ballona Gap.....                                                                                    | 200         |
|               | 12. Chemical character of contaminated waters from wells in Ballona Gap adjacent to the west and north flanks of Baldwin Hills.....                                                 | 208         |
|               | 13. Chloride content of waters from wells 2/14-5C1 and 2/14-5F2.....                                                                                                                | 209         |
|               | 14. Chloride content of waters and record of perforations for seven wells at the Sentney plant, Southern California Water Co.....                                                   | 211         |
|               | 15. Chloride and bicarbonate content of waters from wells 2/15-34A1 and 34K1.....                                                                                                   | 216         |
|               | 16. Chloride content of waters from seven public-supply wells of the city of El Segundo.....                                                                                        | 220         |



CONTENTS

IX

|                                                                                                                                                                                                | Page |
|------------------------------------------------------------------------------------------------------------------------------------------------------------------------------------------------|------|
| <b>FIGURE</b> 17. Chemical character of native and progressively contaminated waters at the main well field of the city of El Segundo....                                                      | 221  |
| 18. Chloride-bicarbonate ratios of progressively contaminated waters at the main well field of the city of El Segundo....                                                                      | 222  |
| 19. Character of water discharged from well 3/15-12L6 during pumping tests.....                                                                                                                | 224  |
| 20. Chloride and sulfate content of progressively contaminated waters from wells 3/15-13E1 and 14A2.....                                                                                       | 228  |
| 21. Chloride content and actual and hypothetical sulfate content of progressively contaminated waters from well 3/15-13G2.....                                                                 | 228  |
| 22. Chloride content of waters from wells 3/15-13E1, 13F2, and 14A2, in relation to duration of pumping.....                                                                                   | 230  |
| 23. Chloride content of waters from selected wells of the Standard Oil Co. at El Segundo.....                                                                                                  | 232  |
| 24. Chloride content of waters from wells 3/14-18N3, 18N4, and 18N5.....                                                                                                                       | 234  |
| 25. Chloride content of waters from selected public-supply wells of the city of Manhattan Beach.....                                                                                           | 238  |
| 26. Chemical character of contaminated waters from selected public-supply wells of the city of Manhattan Beach.....                                                                            | 239  |
| 27. Relationship of chloride, bicarbonate, and sulfate in contaminated waters from public-supply wells of the city of Manhattan Beach.....                                                     | 240  |
| 28. Conductivity traverses in well 3/15-25H1.....                                                                                                                                              | 242  |
| 29. Chloride content of waters from five wells in the Redondo Beach area.....                                                                                                                  | 245  |
| 30. Chemical character of selected native waters and the progressively contaminated water from well 4/14-5N2 in the Redondo Beach area.....                                                    | 247  |
| 31. Progressively contaminated waters from well 4/14-5N2 (Redondo Union High School well) in relation to hypothetical mixtures of native fresh water with oil-well brine (well 4/14-9D).....   | 248  |
| 32. Progressively contaminated waters from well 4/14-5N2 (Redondo Union High School) in relation to hypothetical mixtures of native fresh water with ocean water.....                          | 249  |
| 33. Chemical character of native waters yielded from the shallow unconfined body, from the "200-foot sand," and from the Silverado water-bearing zone beneath Torrance plain near Gardena..... | 256  |
| 34. Chloride content of waters from wells 5/13-6D1 and 6D2, also from wells 4/13-30G1 and 31E1.....                                                                                            | 258  |

## TABLES

| TABLE |                                                                                                                                                                                        | Page |
|-------|----------------------------------------------------------------------------------------------------------------------------------------------------------------------------------------|------|
| 1.    | Monthly and yearly average of temperature and precipitation at three climatological stations in or adjacent to the Torrance-Santa Monica area.....                                     | 13   |
| 2.    | Rainfall at Los Angeles, in inches, in the years ending June 30, 1877-1946.....                                                                                                        | 14   |
| 3.    | Stratigraphy of the Torrance-Santa Monica area.....                                                                                                                                    | 24   |
| 4.    | Range in thickness and depth (in feet) to the base of the unnamed upper Pleistocene deposits in the northern and central parts of the Torrance-Inglewood subarea.....                  | 38   |
| 5.    | Yield characteristics of 39 wells tapping the Silverado water-bearing zone in the Torrance-Santa Monica area.....                                                                      | 52   |
| 6.    | Yield characteristics of eight wells tapping the San Pedro formation in the vicinity of Ballona Gap.....                                                                               | 55   |
| 7.    | Yearly withdrawal of ground water by municipalities in the Torrance-Santa Monica area.....                                                                                             | 101  |
| 8.    | Estimated yearly withdrawal of ground water from the Torrance-Inglewood subarea, in acre-feet, 1931-45.....                                                                            | 106  |
| 9.    | Withdrawal of ground water, in acre-feet, from the Culver City subarea by the city of Santa Monica and by the Southern California Water Co., 1931-45.....                              | 107  |
| 10.   | Agencies withdrawing ground water from the coastal zone of the Torrance-Santa Monica area in 1945 for public supply or industrial use.....                                             | 110  |
| 11.   | Scope of water-level records available from wells in the coastal zone of the Torrance-Santa Monica area, as of July 1946..                                                             | 113  |
| 12.   | Wells in or near the west basin for which hydrographs are plotted on figures 4 and 5 and plates 13 and 14.....                                                                         | 117  |
| 13.   | Estimated storage change in the Torrance-Inglewood subarea from March 1933 to April 1941 for the Silverado water-bearing zone and correlative aquifers in the San Pedro formation..... | 151  |
| 14.   | Estimated storage change in the Torrance-Inglewood subarea from March 1933 to April 1941 for the "200-foot sand" and correlative deposits of upper Pleistocene age.....                | 152  |
| 15.   | Average water-level differentials, in feet, across the barrier features of the Newport-Inglewood uplift between the Baldwin Hills and Long Beach, 1904-45.....                         | 158  |
| 16.   | Analyses of representative native ground waters.....                                                                                                                                   | 172  |
| 17.   | Quantities of water produced from oil fields in the Torrance-Santa Monica area in 1940.....                                                                                            | 188  |
| 18.   | Contaminated water from wells 2/15-9N6, 16J1, and 26C1....                                                                                                                             | 201  |
| 19.   | Sulfate content of water from selected wells in the coastal part of Ballona Gap.....                                                                                                   | 203  |
| 20.   | Chloride, bicarbonate, and sulfate content of water samples from Ballona Creek and its tributaries or points of inflow, 1931-40.....                                                   | 205  |
| 21.   | History and chloride content of public-supply wells of the city of El Segundo.....                                                                                                     | 218  |

CONTENTS

XI

|                                                                                                                                                                                                       | Page |
|-------------------------------------------------------------------------------------------------------------------------------------------------------------------------------------------------------|------|
| <b>TABLE 22.</b> Comparison of actual and hypothetical sulfate content in progressively contaminated waters in the main well field of the city of El Segundo.....                                     | 223  |
| 23. History and chloride content of wells at the Standard Oil Co., El Segundo refineries.....                                                                                                         | 227  |
| 24. Contaminated water from well 3/15-13E1.....                                                                                                                                                       | 231  |
| 25. Sulfate content of contaminated water from certain wells in sec. 18, T. 3 S., R. 14 W., and sec. 13, T. 3 S., R. 15 W.....                                                                        | 235  |
| 26. Description of water wells in the coastal zone of the Torrance-Santa Monica area (excluding minor area at north end of coastal zone, in which locations of wells were not verified in field)..... | 274  |
| 27. Data on wells in the inland zone of the Torrance-Santa Monica area and in the northern 22 square miles (uncanvassed) in the coastal zone.....                                                     | 364  |
| 28. Materials penetrated by typical water wells in the coastal zone.....                                                                                                                              | 368  |
| 29. Field analyses of waters from wells in the coastal zone area, 1943-46.....                                                                                                                        | 386  |
| 30. Chemical analyses of representative native and contaminated waters from the deposits penetrated by water wells, 1925-46..                                                                         | 397  |
| 31. Chemical analyses representing the character of known or potential contaminants in the area.....                                                                                                  | 418  |

---

## GEOLOGY, HYDROLOGY, AND CHEMICAL CHARACTER OF GROUND WATERS IN THE TORRANCE-SANTA MONICA AREA, CALIFORNIA

By J. F. POLAND, A. A. GARRETT, and ALLEN SINNOTT

---

### ABSTRACT

The coastal plain in Los Angeles County, southern California, is divided into two distinct ground-water basins by the Newport-Inglewood uplift. On the northeast or inland side is the main coastal basin; on the southwest, bordering the Pacific Ocean and extending from Long Beach to Santa Monica, is the so-called west basin. The Torrance-Santa Monica area, as identified here, embraces the western part of the coastal plain and spans the entire west basin.

The west basin, which includes about 180 square miles, is an area of expanding population and of rapid industrial growth. Its water supply for domestic, industrial, and irrigation uses is obtained chiefly from wells. In the part of the west basin south of the Ballona escarpment—the Torrance-Inglewood subarea of this report—the draft on ground water has been excessive for many years; and local water levels, which were drawn down to about sea level by 1930, now are as much as 70 feet below sea level. Saline contamination has developed extensively along the coast, and the ground-water supply is threatened with ultimate deterioration if the present draft is maintained.

This investigation, which covers the period from 1943 to 1947, was for the purpose of appraising the geologic conditions controlling the occurrence and circulation of ground water, the replenishment to the west basin, and the extent and sources of saline contamination and methods for its control.

The dominant geologic formations of the area are of Tertiary and Quaternary age. The Tertiary rocks, of Miocene and Pliocene age, are formed almost entirely of marine deposits and consist chiefly of shale, siltstone, and sandstone. Except in their uppermost part, they contain connate saline waters. The lower part of upper division of the Pico formation (the youngest rocks of Pliocene age) has several relatively permeable sand members which collectively average at least 200 feet in thickness. These sand members have not been tapped by water wells; however, they contain essentially fresh water and constitute a reserve supply. It would be expensive to develop this supply because the wells would have to be at least 1,500 feet deep and would require special construction to hold back the sand.

The Quaternary rocks, chiefly of Pleistocene age, contain almost all of the aquifers now tapped by water wells. Deposits of Recent age in the west basin occur only within the Dominguez and Ballona Gaps. The Pleistocene deposits, which underlie most of the Torrance-Santa Monica area, comprise three units which, in downward succession, are: (1) a capping terrace deposit and the Palos Verdes sand, which is composed of sand, silt, and gravel, commonly not more than 30 feet thick and, for the most part, above the water table; (2) the unnamed upper

---

## 2 GEOLOGY, HYDROLOGY, TORRANCE-SANTA MONICA AREA

Pleistocene deposits consisting of silt, clay, sand, and gravel, which are as much as 400 feet thick and are of fluvial and marine origin; and (3) the San Pedro formation (composed of about half sand and gravel and half silt and clay) which is as much as 1,000 feet thick and mostly of marine origin within the west basin. The Silverado water-bearing zone and correlative aquifers in the San Pedro formation yield about 90 percent of the ground water pumped from the west basin. The thickness of this principal aquifer ranges from 50 to 700 feet; its extent within the west basin is about 120 square miles. From pumping tests its permeability has been determined as ranging from 1,000 to 2,000 gallons per day per square foot (gpd per sq ft).

The deposits of Recent age are the latest contributions to the alluvial fans of the Los Angeles and San Gabriel Rivers. They underlie the Downey plain and extend across the west basin as two tongues in Dominguez and Ballona Gaps. The upper division is fine sand and silt, but the lower division is highly permeable coarse sand and gravel, as much as 75 feet thick in Dominguez Gap.

The Newport-Inglewood uplift—a regional anticlinal fold—is ruptured by a series of faults, which form a discontinuous but substantial barrier to underflow from the main coastal basin to the west basin. These faults cut all rocks except those of Recent age.

Three distinct bodies of ground water occur in the area. In downward succession these are: (1) a body of shallow unconfined and semiperched water of inferior quality under natural conditions, which extends to a few tens of feet below the land surface; (2) the principal body of fresh ground water, which occupies almost all the deposits of Recent and Pleistocene age and the upper part of the underlying Pliocene rocks (extending to depths as much as 2,500 feet below land surface in the west basin and 8,000 feet in the main coastal basin), which contains water of good quality; and (3) a body of saline connate water underlying the principal fresh-water body.

The principal body of fresh ground water underlies most of the Torrance-Santa Monica area and occurs beneath the greater part of the west basin. Except near Redondo Beach and north of El Segundo, where a water table exists, the aquifers of the principal water body are confined and separated from each other by substantial thicknesses of relatively impermeable silt or clay.

In the Torrance-Inglewood subarea (the part of the west basin south of the Ballona escarpment), withdrawals of ground water increased from nearly 10,000 acre-feet in 1904 to about 48,000 acre-feet per year in the thirties, and then rose to about 78,000 acre-feet in 1945, because of accelerated demands in the war years. In 1945 about half the withdrawal was used for industrial purposes.

As a result of this increase in draft, water levels noticeably declined in the early twenties and were drawn down to or below sea level throughout the subarea by 1930. A slow, irregular decline continued through 1941, when the decline was accelerated by the increased water demands of the war years. In 1946, local pressure levels in the Silverado water-bearing zone were as much as 70 feet below sea level near the inland boundary of the basin. Because of the impermeable confining beds and disproportionate draft, water levels in the several aquifers have been drawn down unequally. For example, in the Gardena area in 1946, the pressure level in the Silverado water-bearing zone was 50 feet below the semiperched water table, 20 feet below the pressure level of the "200-foot sand" and about 9 feet below that of the "400-foot gravel."

Under the early conditions of ground-water development, replenishment to the west basin occurred (1) by underflow across the Newport-Inglewood uplift, (2) by direct infiltration of rainfall and return water from irrigation on the land surface, (3) by infiltration of local runoff, and (4) by seepage from the channel

of the Los Angeles River to the south and from Ballona Creek and its tributaries to the north. With the drawdown in water levels to and below sea level, water has been added to the basin in substantial quantity by landward encroachment of saline waters from the ocean and from the subsea extensions of the aquifers. Water also has been withdrawn from storage in the water-table reaches by compaction of the water-bearing system in the confined reaches.

The replenishment to the Torrance-Inglewood subarea under native conditions is estimated to have been within the range of 30,000 to 40,000 acre-feet per year. From 1933 to 1941 the draft averaged 48,000 acre-feet per year. It is estimated that about 2,000 acre-feet per year was withdrawn from storage, about 12,000 acre-feet per year was contributed from the subsea extension of the aquifers or from the ocean, and nearly 34,000 acre-feet per year was contributed by net fresh-water replenishment from all sources.

The underflow across the Newport-Inglewood uplift varies with the differential in pressure head across the barrier faults. For the reach from the Baldwin Hills to Long Beach, the average differential is estimated to have decreased from about 40 feet in 1904 to 28 feet in 1941 and to have increased to about 36 feet in 1945 with the accelerated drawdown in the west basin. The underflow into the Torrance-Inglewood subarea in 1945 is estimated as from approximately 15,000 to 20,000 acre-feet, or about 85 percent as much as the underflow during 1904. By 1945 the underflow is believed to have constituted nearly one-half the fresh-water replenishment, and the probable excess of draft over net replenishment was at least 40,000 acre-feet in that year. A major part of this excess draft was replaced by invasion of ocean water.

In the west basin the native waters of good quality in the principal water body range in character from calcium bicarbonate to sodium bicarbonate, and their chloride content ranges from 25 to 90 ppm. For native inferior waters—those in which dissolved solids are in excess of 600 ppm—the chloride content is as great as 500 ppm.

The potential contaminants of the ground water in the west basin are ocean water, oil-field brines, and industrial wastes. The ocean water contains dissolved solids of about 34,000 ppm and chloride content of about 19,000 ppm. The oil-field brines are connate waters from the Tertiary rocks and range in dissolved solids about from 10,000 to 39,000 ppm. The ocean waters are in contact with the subsea extensions of the aquifers; the oil-field and industrial wastes have been discharged at the land surface and in stream channels.

In the twenties and early thirties, in response to the drawdown of the water level in the west basin, certain wells tapping the principal water body along the west coast between Santa Monica and Redondo Beach began to yield saline water. Contamination also developed near the Baldwin Hills and in Dominguez Gap about that time.

In general, the contaminated waters are not simple mixtures of the contaminant and native waters but have been so greatly modified that the nature of the contaminant is very obscure. Such modification is caused chiefly by base exchange—substitution of calcium and magnesium for sodium—and by sulfate reduction.

In the coastal part of Ballona Gap contamination started in the twenties and by 1931 extended beneath nearly 5,100 acres; by 1946 this contamination extended to about 7,300 acres. Inland for about 1.6 miles (near Lincoln Boulevard) the contaminated waters contain more than 500 ppm of chloride. The contaminant at this point is almost wholly ocean water. Contaminated waters extend about 3 miles inland in the Ballona Gap and range in chloride content from 100 to 500 ppm. The source of the contaminant is not definitely known, but the high sulfate content indicates that the shallow unconfined waters are a

---

#### 4 GEOLOGY, HYDROLOGY, TORRANCE-SANTA MONICA AREA

principal source. Adjacent to the west and north flanks of the Baldwin Hills, oil-field wastes have contaminated two areas. The contamination on the west flank is increasing but on the north flank it has receded since the thirties.

Along the 11-mile coastal reach, from the Ballona escarpment (Playa del Rey) to the Palos Verdes Hills, salt water has invaded the main water-bearing zones. Contamination was first noted at Hermosa Beach about 1915 and at El Segundo in 1921. By 1931 the coastal area underlain by contaminated waters amounted to almost 5,000 acres, and the greatest inland extent was about 1.3 miles, at El Segundo. By 1946 the contaminated area had increased by about 1,700 acres. In the last 14 years the greatest advance of the front was between El Segundo and Manhattan Beach and was as much as 0.5 mile. In the reach from the Palos Verdes Hills to Hermosa Beach the average rate of advance of the front was about 90 feet per year from 1931 to 1941, and it had increased to about 140 feet per year by 1946. From Hermosa Beach to El Segundo the average rate of advance in the thirties was about 115 feet a year, but it was as much as 300 to 400 feet per year by 1946. The chief source of contamination along the west coast is ocean water. Near El Segundo, part of the early contamination seems to have developed from locally discharged high-sulfate waters.

In Dominguez Gap the Gaspur water-bearing zone, of Recent age, is extensively contaminated in two principal areas. Along the coast and inland, as far as the Pacific Coast Highway (State Street), this zone is highly contaminated with ocean water. Inland from this highway to Carson Street, about 3 miles, the Gaspur zone is contaminated by waste brines from the Long Beach oil field. The Silverado water-bearing zone, which underlies the Gaspur zone but is separated from it by relatively impervious deposits several hundred feet thick, is uncontaminated as of 1947; however, it can become contaminated by downward movement of saline water through abandoned wells unless these wells are properly sealed. The contamination in the Gaspur water-bearing zone is not moving inland; it is moving slowly westward into the upper Pleistocene deposits, and ultimately will reach the Silverado water-bearing zone if the present water-level differentials of as much as 70 feet are maintained.

The continued inland advance of ocean water into the west basin, especially from the west coast, would result in ultimate destruction of the supply of fresh water. The water rights in the Torrance-Inglewood subarea now are being adjudicated because it is recognized that the water supply is being excessively depleted and is being replaced by salt water. In most ground-water basins bordering on the ocean, the most effective long-term program for restraining or driving back saline waters depends upon raising water levels throughout the basin to such a height that fresh-water levels at the saline front will displace salt water seaward. Such raising of water levels ordinarily does not greatly affect replenishment procedures.

However, in the Torrance-Inglewood subarea almost half the current replenishment is derived by underflow across the barrier features. If the restraint of ocean water should be achieved by raising water levels above sea level throughout the basin, and if water levels inland should remain at sea level, underflow across the Newport-Inglewood barrier would cease and half of the replenishment would be lost. Therefore, it seems that the amount of the natural fresh-water yield from the basin will remain substantial only if the salt water can be restrained by local control near the coast and water levels immediately coastward from the barrier can be held low enough to induce continued underflow across the barrier.

Only three physical possibilities seem capable of such local control of saline waters: (1) the construction of artificial subsurface dikes or cut-off walls; (2) the development, by pumping, of a water-level trough coastward from the saline

front; and (3) the maintenance of fresh-water head above sea level at and immediately inland from the saline front. Only the maintenance of fresh-water head is considered to be an economic possibility. The fresh-water head required along the west coast would range from 3 to 13 feet above sea level. It could be attained only by artificial recharge through wells, trenches, or pits.

## INTRODUCTION

## LOCATION AND GENERAL FEATURES OF THE AREA

The Torrance-Santa Monica area, as identified in this report, embraces the western part of the coastal plain in Los Angeles County, in southern California. Its location is shown by figure 1 and some

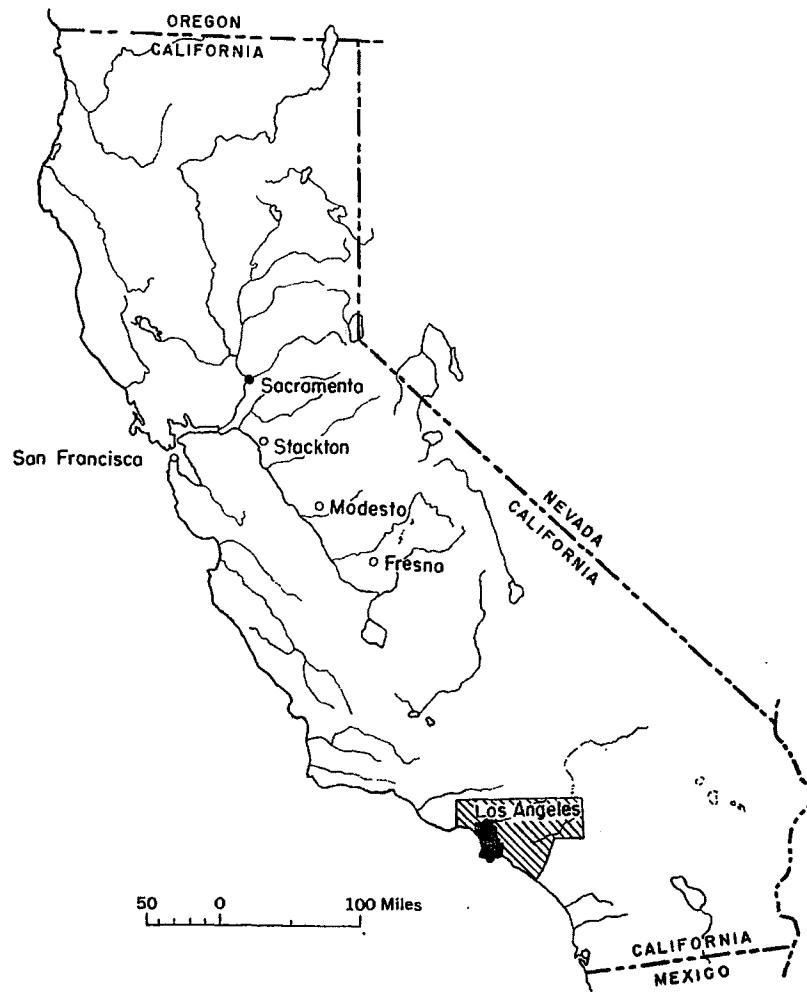

FIGURE 1.—Map of California showing area covered by this report and that covered by plate 1.  
460508—59—2



of its general features are shown by plate 1. It is bounded on the north by the Santa Monica Mountains, on the south by the Palos Verdes Hills, and on the west by the Pacific Ocean. It encompasses about 280 square miles, spans the entire west basin of Eckis (1934, p. 198) and extends inland beyond the axis of the Newport-Inglewood uplift. This uplift, which extends about 40 miles southeastward from Beverly Hills to Newport Beach (pl. 1), divides the coastal plain of Los Angeles County into two distinct ground-water basins. On the northeast or inland side is the main or "central" coastal basin, which includes about 500 square miles in Los Angeles and Orange Counties. As of 1948 about one-third of a million acre-feet of ground water is pumped annually to supply municipalities, diversified industries, and extensive agricultural developments from the central basin.

The ground-water basin on the southwest or coastal side of the uplift extends from Santa Monica to Long Beach and is flanked on the southwest by the Palos Verdes Hills and the Pacific Ocean. It was designated the west basin by Eckis, but in recent references by the California Division of Water Resources it has been called the west coast basin. The shorter term by Eckis is used in this report.

The approximate dimensions of the west basin are 25 miles long, 7 miles wide, and 180 square miles in area. It is an area of expanding population and of rapid industrial growth. Two-fifths of the 180 square miles consists of a residential development with a population of at least 300,000. Irrigated farmland covers about one-fifth of the area. The city of Santa Monica is supplied with water from the Metropolitan Water District, but the water supply for domestic, industrial, and irrigation uses is obtained almost entirely from wells. In the part of the west basin south of the Ballona escarpment the draft on ground water has been excessive for many years, and local water levels, which nearly reached sea level by 1930, now (1948) are as low as 70 feet below sea level. As a result, saline contamination has developed in three areas along the coast and the ground-water supply of most of the basin is threatened with ultimate deterioration if the present draft is maintained or increased.

#### SCOPE OF THE INVESTIGATION AND OF THIS REPORT

Because of the critical ground-water situation in the west basin, in July 1943 an agreement for a cooperative ground-water investigation was made between the U. S. Geological Survey and the Los Angeles County Flood Control District. In addition to its own interest, the District also represented the joint interests of nine cities intimately concerned with the preservation of the ground-water supplies—the cities of Inglewood, Redondo Beach, Manhattan Beach, El Segundo, Hawthorne, Culver City, Gardena, Hermosa Beach, and

Palos Verdes Estates. All these communities obtain water wholly or partly from well fields in the west basin; several of these well fields have been affected or are threatened by saline encroachment—especially the wells that supply Redondo Beach, Hermosa Beach, Manhattan Beach, and El Segundo.

The cooperative investigation of the west basin area was undertaken to appraise: (1) the geologic conditions which control the occurrence and circulation of ground water; (2) the replenishment to the west basin; and (3) the chemical character of the ground water with special reference to saline contamination.

The investigation, which began in October 1943, was under the general direction of O. E. Meinzer, chief geologist. Upon his retirement, A. N. Sayre served in that capacity. Until mid-1946 the project was under the supervision of district geologist A. M. Piper. A. A. Garrett and Allen Sinnott, of the field office at Long Beach, did most of the field operations under the supervision of J. F. Poland, district geologist. Garrett made the partial chemical analyses of well waters. This report is under the combined authorship of Poland, Garrett and Sinnott; the section treating the geology is largely the work of Sinnott and the section on chemical character is chiefly the work of Garrett. The hydrologic interpretations and text were prepared by Poland.

The Geological Survey has made an intensive study of ground-water features in the coastal zone of 240 square miles that extends from Long Beach to Santa Monica, spans all the west basin, and extends inland for about 3 miles beyond the axis of the Newport-Inglewood uplift. The Survey also made a general study of selected ground-water features in a contiguous inland zone of 40 square miles that extends to the western boundary of the Long Beach-Santa Ana area. These two zones comprise the Torrance-Santa Monica area; the boundaries of this area and those of the Long Beach-Santa Ana area are shown on plate 1. It will be noted on plate 1 that the area immediately west of Long Beach (50 square miles comprising Dominguez Gap and vicinity) is common to both areas. Although the ground-water features of Dominguez Gap and vicinity were studied in the earlier investigation, the area lies within the scope of this report and is the area of the most intensive ground-water draft within the west basin.

The Geological Survey has released two reports on its work in the Torrance-Santa Monica area. A progress report (Poland, Garrett, and Sinnott, 1944) was prepared after the first year of work to outline the general ground-water conditions and to indicate the current extent of saline contamination in the critical area from Redondo Beach to El Segundo. In 1946 a factual well index was issued (Sinnott and Garrett, 1946), which for the canvassed extent of the coastal zone pre-

sents brief tabulated descriptions of nearly all of the active or potentially active water wells and of those abandoned wells for which data are available (incorporated in this report as table 26). This index also summarizes the sources and scope of the available well records, chemical analyses of water from wells, measurements of depth to water, and logs of wells. Wells were not canvassed by the Geological Survey in 62 square miles of the Torrance-Santa Monica area; however, a brief tabulated record of pertinent well data was prepared from records supplied by the California Division of Water Resources, the Los Angeles County Flood Control District, the Los Angeles Department of Water and Power, and other agencies (table 27).

The present report gives the findings and conclusions relating to the geology, hydrology, and chemical character of the ground waters in and adjacent to the west basin. Because ground-water conditions are most critical in the part of the west basin that is south of the Ballona Gap, the report treats that area in greater detail. This report was first released to the public in 1948, in duplicated form. Publication has been delayed in part by the decision to wait until the revised topographic sheets of the area became available for the base map. The last of these was supplied in 1953.

From 1940 to 1946 the Geological Survey made an intensive investigation of ground-water conditions within the southern part of the coastal plain—from Dominguez Hill southeast to Newport Beach—with special reference to saline contamination and the effectiveness of the barrier features of the Newport-Inglewood uplift to restrain inland movement of ocean water. The area of study embraced almost all the coastal plain east of Vermont Avenue and was called the Long Beach-Santa Ana area. From that investigation four interpretive reports had been released to the public in duplicated form by 1946.<sup>1</sup> These reports are being published in three water-supply papers (Piper, Garrett, and others, 1953; Poland, Piper, and others, 1956; Poland, 1959). Because the Long Beach-Santa Ana area is adjacent to and, in T. 4 S., R. 13 W., overlaps the Torrance-Santa Monica area, they have many features in common. Thus, in this report, frequent reference is made to matters treated in the reports on the Long Beach-Santa Ana area.

<sup>1</sup> Poland, J. F., Piper, A. M., and others, 1945, Geologic features in the coastal zone of the Long Beach-Santa Ana area, California, with particular respect to ground-water conditions: U. S. Geol. Survey duplicated report, 527 p. Poland, J. F., Sinnott, Allen, and others, 1945, Withdrawals of ground water from the Long Beach-Santa Ana area, California, 1932-41: U. S. Geol. Survey duplicated report, 112 p. Piper, A. M., Garrett, A. A., and others, 1946, Chemical character of native and contaminated ground waters in the Long Beach-Santa Ana area, California: U. S. Geol. Survey duplicated report, 356 p. Poland, J. F., and others, 1946, Hydrology of the Long Beach-Santa Ana area, California, with special reference to the water-tightness of the Newport-Inglewood structural zone: U. S. Geol. Survey duplicated report, 198 p.

**OTHER INVESTIGATIONS**

The first investigation of the ground waters within the western part of the coastal plain was made by Mendenhall (1905a, 1905b) in 1903-4. At that time about 2,500 active wells within the extent of the Torrance-Santa Monica area were visited, and readings were made of depth to water, and of chemical quality as measured by electrical resistance.

From 1904 to 1926 the Geological Survey continued periodic measurements of depth to water on a few selected wells. Of these, 26 were within the Torrance-Santa Monica area, but measurements for all but 3 wells were discontinued prior to 1926. Their records through 1920 have been published by the Geological Survey (Ebert, 1921, p. 13-29).

From the middle twenties to 1941 the Los Angeles Department of Water and Power made periodic measurements of depth to water in many wells within the part of the coastal plain in Los Angeles County. Of these, several hundred were within the Torrance-Santa Monica area. No interpretive reports have been published by that agency as a result of this program but the measurements have been made available for use in the preparation of this report.

Since 1929 the Los Angeles County Flood Control District has been collecting a large mass of basic data, chiefly in the form of water-level measurements, chemical analyses from wells and streams, and well logs. In its series of annual reports, that agency has published semi-annual water-level contour maps and selected hydrographs. Also, it has prepared brief reports or summary statements treating the problems of saline contamination along the coast of Los Angeles County within the west basin. The earliest of these reports is believed to be one prepared by Donald Seal (1931), in which the author pointed out the presence of saline contamination along the coast and the danger of its expansion inland. The saline encroachment was treated more fully by Dockweiler (1932) in a report on the so-called Nigger Slough project for flood control and conservation. The report included a plan for artificial recharge of the ground water by injection through wells. In 1935 the Flood Control District began a study of saline contamination in Ballona Gap, in connection with the construction of the new Ballona Creek flood control channel. The results of the study were issued in several progress reports and summarized in a final report by Koch (1940).

Since the late twenties the California Division of Water Resources has acted as a collecting agency and its Los Angeles office has been a depository for factual information relating to ground-water supplies, especially measurements of depth to water, chemical analyses, and well logs. Some of the measurements and chemical analyses have been made by its own staff but most of the work was done by other

agencies, although the data were assembled by the Division. For many years the Division has been investigating the water supplies available to the ground-water basins of the Los Angeles area and it has issued several factual and interpretive reports relating in part to the west basin area (Gleason, 1932; Scofield, 1933; Eckis, 1934). In 1944 the California Division of Water Resources issued a brief statement on ground-water conditions in the west basin.

Since 1929, the water department of the city of Long Beach has made periodic measurements of depth to water in about a dozen wells in Dominguez Gap. Also in 1932 the water department began making periodic determinations of the chloride content of water samples usually taken once a month from 40 to 50 wells in Dominguez Gap. The measurements and analyses have been continued to date.

In connection with an appraisal of water supply and use of ground water in southern California, the Metropolitan Water District has prepared two reports concerned with ground water conditions in the southern part of the west basin (Vail, 1932; 1942).

After the cooperative investigation in the west basin was started by the Geological Survey, and partly as a result of the findings in the Survey's progress report of 1944, water users in the part of the west basin south of Ballona Gap organized a "West Basin Ground Water Conservation Group" to investigate and report on the problems confronting water producers and users in the area. A Ways and Means Committee of that group, appointed in March 1945, published its findings in September 1945 (Anon., September 1945).

The findings and conclusions of the Ways and Means Committee report led to the organization of the West Basin Water Association late in 1945, a nonprofit organization comprised of many of the water users in the parent group. The Water Association has released a report by Harold Conkling (1946), which appraised the possibilities of the importation of water.

Knowledge concerning the saline encroachment and the increasing overdraft upon the ground-water supplies had been widely disseminated by mid-1945, and in October of that year legal action was brought by three water users in the west basin for the purpose of seeking adjudication of the rights of each producer of ground water in the part of the basin south of Ballona Gap. In July 1946 the California Division of Water Resources was appointed as referee to investigate and report on physical facts pertinent to the action (Gleason, 1946). (See p. 262.)

#### ACKNOWLEDGMENTS

The U. S. Geological Survey has made extensive use of the data and reports summarized in the preceding section of this report. The

basic data collected by the Los Angeles County Flood Control District, the California Division of Water Resources, and the Los Angeles Department of Water and Power have been of immeasurable value in this investigation. Acknowledgment also is made of valuable data supplied by the cities of El Segundo, Hawthorne, Inglewood, Long Beach, and Manhattan Beach; by the Southern California Water Co., the California Water Service Co., and the Dominguez Water Corp.; by the many industrial plants that produce water from the west basin, especially the Standard Oil Co. at El Segundo for the many chemical analyses and the results of its test-pumping operations on a well tapping the upper division of the Pico formation; and the Union Oil Co. for its cooperation in making a pumping test to determine ground-water conditions in the vicinity of Bixby Slough; also, by many other agencies and individuals that cooperated fully in making their data available.

Substantial contributions on geological data appearing in this report have been made by several oil companies, especially the Standard Oil Co. of California for making available an unpublished map of the surface geology of the Baldwin Hills, by G. B. Moody. With reference to stratigraphic problems, special acknowledgment for microfaunal information is due S. G. Wissler of the Union Oil Co. and M. L. Natland of the Richfield Oil Corp. Sample suites from water wells were obtained through the cooperation of the Roscoe Moss Co. by Paul Karnes and Mr. Bromwell, drillers; and also through the city of Long Beach. Cores from several wells were received from the Kalco Drilling Co. through C. C. Killingsworth; M. R. Peck furnished several logs.

Electric logs of oil wells, supplied through the courtesy of many oil companies, were utilized in correlating the deeper fresh-water zones and in determining the depth to the body of saline connate water that underlies the fresh-water body throughout the area.

#### NUMBERS APPLIED TO WELLS BY THE GEOLOGICAL SURVEY

In its cooperative programs on the coastal plain and elsewhere in California, the Geological Survey has designated wells by numbers that indicate the respective locations according to rectangular land surveys. For example, for well 3/14-36M3, the first part of the Geological Survey number indicates the township and range (T. 3 S., R. 14 W., San Bernardino base line and meridian), the two digits following the hyphen indicate the section (sec. 36), and the letter indicates the 40-acre subdivision of the section as shown on the accompanying diagram.

|   |   |   |   |
|---|---|---|---|
| D | C | B | A |
| E | F | G | H |
| M | L | K | J |
| N | P | Q | R |

Within each 40-acre tract the wells are numbered serially as indicated by the final digit or digits of the number. Thus, well 36M3 is in the NW $\frac{1}{4}$ SW $\frac{1}{4}$  sec. 36 and is the third well in that tract to be listed.

In the parts of the area that once were public land, the official Federal land survey is followed. Elsewhere the net is projected, but most of the land has been subdivided according to extensions of the Federal Survey so that the system can be applied readily.

This system of numbers has also been used as a convenient means of locating a feature described in the text. Thus, an area or feature within the NW $\frac{1}{4}$ NW $\frac{1}{4}$  sec. 7, T. 3 S., R. 14 W. (projected land lines), may be identified as 3/14-7D.

#### SUBDIVISIONS OF THE WEST BASIN WITH RESPECT TO GROUND WATER

For purposes of this report, the west basin is divided into two parts. The area extending from the Ballona escarpment (pl. 8) southeast to the Los Angeles River flood-control channel west of Long Beach forms a hydrologic unit that is believed to be essentially unbroken by barrier faults except those which bound the basin. This area, which includes some 135 square miles, or about three-quarters of the west basin, is identified in this report as the Torrance-Inglewood subarea. It is the area of the most intensive regional lowering of water level and, as late as 1945, it yielded more than 80 percent of the water withdrawn from the west basin. Also, this is the area involved in the pending suit for adjudication of water rights.

The area extending from the Ballona escarpment north to the Santa Monica Mountains, and including the Ballona Gap, is traversed by several faults which interrupt hydraulic continuity in the Pleistocene water-bearing deposits and produce conditions of localized groundwater movement. This area, about 45 square miles in extent, is identified in this report as the Culver City subarea.

## CLIMATE

The climate of the Torrance-Santa Monica area is mild and is characterized by a wet and a dry season. The average annual rainfall is 12 to 16 inches throughout the area. About 95 percent of the rainfall occurs in the 7 months from October through April, principally from storms originating in the north Pacific area and moving inland from the ocean; at times, however, rain develops from storms moving northwestward from the Caribbean area and across Mexico.

The prevailing winds are from the west and northwest and carry moisture over the land from the Pacific Ocean. These winds quickly lose much of their moisture as they pass eastward across the land. Within the west basin, however, their moisture content is sufficient to substantially reduce the requirements for irrigated crops below those of the interior valleys.

The mean annual temperature at Santa Monica, on the coast, is about 60°F; the temperature ranges from 53° in January to 66° in August. The hottest and driest periods occur when infrequent winds sweep coastward from the interior deserts. Table 1 gives monthly and yearly averages of temperature and precipitation for Long Beach and Santa Monica at opposite ends of the area, and for Los Angeles, at the inland margin. In a recent publication, Gleason (1947, pl. 21) has included a map showing lines of equal precipitation (mean for the 53-year period) for the entire south coastal basin. The distribution and magnitude of average yearly rainfall in the west basin and the increase in rainfall inland to the San Gabriel Mountains are well shown on that map.

TABLE 1.—*Monthly and yearly averages of temperature and precipitation at three climatological stations in or adjacent to the Torrance-Santa Monica area in the period ending 1946*

[From publications of U. S. Weather Bureau]

|                | Long Beach                  |                                   | Los Angeles                   |                                     | Santa Monica                  |                                     |
|----------------|-----------------------------|-----------------------------------|-------------------------------|-------------------------------------|-------------------------------|-------------------------------------|
|                | Temperature (°F)<br>1926-46 | Precipitation (inches)<br>1920-46 | Temperature (°F)<br>1876-1946 | Precipitation (inches)<br>1876-1946 | Temperature (°F)<br>1889-1922 | Precipitation (inches)<br>1884-1922 |
| January.....   | 53.7                        | 2.18                              | 54.6                          | 3.10                                | 52.8                          | 3.51                                |
| February.....  | 55.4                        | 2.90                              | 55.5                          | 3.07                                | 53.1                          | 2.95                                |
| March.....     | 57.6                        | 1.61                              | 57.5                          | 2.78                                | 55.4                          | 2.85                                |
| April.....     | 59.9                        | .88                               | 59.4                          | 1.04                                | 57.8                          | .52                                 |
| May.....       | 63.1                        | .31                               | 62.2                          | .45                                 | 60.0                          | .46                                 |
| June.....      | 65.9                        | .08                               | 64.4                          | .08                                 | 63.2                          | .02                                 |
| July.....      | 70.2                        | -----                             | 70.2                          | .01                                 | 65.9                          | 1 T.                                |
| August.....    | 70.6                        | .04                               | 71.1                          | .02                                 | 66.4                          | .03                                 |
| September..... | 68.5                        | .30                               | 69.0                          | .17                                 | 64.8                          | .14                                 |
| October.....   | 64.4                        | .55                               | 65.3                          | .68                                 | 62.0                          | .61                                 |
| November.....  | 60.2                        | .71                               | 60.9                          | 1.20                                | 58.3                          | 1.37                                |
| December.....  | 56.1                        | 2.74                              | 56.6                          | 2.63                                | 54.6                          | 2.32                                |
| Annual.....    | 62.1                        | 12.20                             | 62.4                          | 15.23                               | 59.5                          | 14.78                               |

1 T=0.005 inch or less of rain or melted snow.



14 GEOLOGY, HYDROLOGY, TORRANCE-SANTA MONICA AREA

In another report (Poland, 1959), rainfall records were tabulated for Los Angeles from 1877 to 1945, and for Long Beach from 1921 to 1945; those for Los Angeles were plotted to show cumulative departure from the yearly mean. Because the rainfall at Los Angeles has been observed since 1877 and furnishes much the longest record for any station in the vicinity of the Torrance-Santa Monica area, it is presented again in table 2. Yearly and cumulated departure from the 68-year average from 1877 to 1945 (years ending June 30) also are shown by the table.

TABLE 2.—Rainfall at Los Angeles, in inches, in the years ending June 30, 1877-1946; also surplus or deficiency (-) with respect to the 68-year average of 1877-1945<sup>1</sup>

[From publications of U. S. Weather Bureau]

| Year      | Rainfall | Surplus or deficiency | Cumulated surplus or deficiency | Year    | Rainfall | Surplus or deficiency | Cumulated surplus or deficiency |
|-----------|----------|-----------------------|---------------------------------|---------|----------|-----------------------|---------------------------------|
| 1877-78   | 21.26    | 5.73                  | 5.73                            | 1912-13 | 13.42    | -2.11                 | -1.36                           |
| 1878-79   | 11.35    | -4.18                 | 1.55                            | 1913-14 | 23.65    | 8.12                  | 6.76                            |
| 1879-80   | 20.34    | 4.81                  | 6.36                            | 1914-15 | 17.05    | 1.52                  | 8.28                            |
| 1880-81   | 13.13    | -2.40                 | 3.96                            | 1915-16 | 19.92    | 4.39                  | 12.67                           |
| 1881-82   | 10.40    | -5.13                 | -1.17                           | 1916-17 | 15.26    | -.27                  | 12.40                           |
| 1882-83   | 12.11    | -3.42                 | -4.59                           | 1917-18 | 13.86    | -1.67                 | 10.73                           |
| 1883-84   | 38.18    | 22.65                 | 18.06                           | 1918-19 | 8.58     | -6.95                 | 3.78                            |
| 1884-85   | 9.21     | -6.32                 | 11.74                           | 1919-20 | 12.52    | -3.01                 | .77                             |
| 1885-86   | 22.31    | 6.78                  | 18.52                           | 1920-21 | 13.65    | -1.88                 | -1.11                           |
| 1886-87   | 14.05    | -1.48                 | 17.04                           | 1921-22 | 19.66    | 4.13                  | 3.02                            |
| 1887-88   | 13.87    | -1.66                 | 15.38                           | 1922-23 | 9.59     | -5.94                 | -2.92                           |
| 1888-89   | 19.28    | 3.75                  | 19.13                           | 1923-24 | 6.67     | -8.86                 | -11.78                          |
| 1889-90   | 34.84    | 19.31                 | 38.44                           | 1924-25 | 7.94     | -7.59                 | -19.37                          |
| 1890-91   | 13.36    | -2.17                 | 36.27                           | 1925-26 | 17.56    | 2.03                  | -17.34                          |
| 1891-92   | 11.85    | -3.68                 | 32.59                           | 1926-27 | 17.76    | 2.23                  | -15.11                          |
| 1892-93   | 26.28    | 10.75                 | 43.34                           | 1927-28 | 9.77     | -5.76                 | -20.87                          |
| 1893-94   | 6.73     | -8.80                 | 34.54                           | 1928-29 | 12.66    | -2.87                 | -23.74                          |
| 1894-95   | 16.11    | .58                   | 35.12                           | 1929-30 | 11.52    | -4.01                 | -27.75                          |
| 1895-96   | 8.51     | -7.02                 | 28.10                           | 1930-31 | 12.53    | -3.00                 | -30.75                          |
| 1896-97   | 16.86    | 1.33                  | 29.43                           | 1931-32 | 16.95    | 1.42                  | -29.33                          |
| 1897-98   | 7.06     | -8.47                 | 20.96                           | 1932-33 | 11.88    | -3.65                 | -32.98                          |
| 1898-99   | 5.59     | -9.94                 | 11.02                           | 1933-34 | 14.55    | -.98                  | -33.96                          |
| 1899-1900 | 7.91     | -7.62                 | 3.40                            | 1934-35 | 21.66    | 6.13                  | -27.83                          |
| 1900-1    | 16.29    | .76                   | 4.16                            | 1935-36 | 12.07    | -3.46                 | -31.29                          |
| 1901-2    | 10.60    | -4.95                 | -.77                            | 1936-37 | 22.41    | 6.88                  | -24.41                          |
| 1902-3    | 19.32    | 3.79                  | 3.02                            | 1937-38 | 23.43    | 7.90                  | -16.51                          |
| 1903-4    | 8.72     | -6.81                 | -3.79                           | 1938-39 | 13.07    | -2.46                 | -18.97                          |
| 1904-5    | 19.52    | 3.99                  | .20                             | 1939-40 | 19.21    | 3.68                  | -15.29                          |
| 1905-6    | 18.65    | 3.12                  | 3.32                            | 1940-41 | 32.76    | 17.23                 | 1.94                            |
| 1906-7    | 19.30    | 3.77                  | 7.09                            | 1941-42 | 11.18    | -4.35                 | -2.41                           |
| 1907-8    | 11.72    | -3.81                 | 3.28                            | 1942-43 | 18.17    | 2.64                  | .23                             |
| 1908-9    | 19.18    | 3.65                  | 6.93                            | 1943-44 | 19.22    | 3.69                  | 3.92                            |
| 1909-10   | 12.63    | -2.90                 | 4.03                            | 1944-45 | 11.59    | -3.94                 | -.02                            |
| 1910-11   | 16.18    | 0.65                  | 4.68                            | 1945-46 | 11.65    | -3.88                 | -3.90                           |
| 1911-12   | 11.60    | -3.93                 | .75                             |         |          |                       |                                 |

<sup>1</sup> Average for 68 seasons, to 1945, 15.53 inches.

**PHYSIOGRAPHY****GENERAL FEATURES**

Most of the major landform features of the coastal plain in Los Angeles and Orange Counties were formed by deformational earth movements during late Pleistocene time. (See table 3 for geologic time classification.) This deformation affected rocks now forming the most important aquifers in the area. Younger aquifers of lesser economic importance were formed by later alluviation in erosional trenches or gaps transecting these deformed older rocks. Thus, a brief discussion of the landforms is pertinent with respect to both the geologic and hydrologic conditions in the area. For a more complete discussion of these landforms, the reader is referred to a previous report in which the physiography of the entire coastal-plain area in Los Angeles and Orange Counties has been treated in detail (Poland, Piper, and others, 1956, p. 11-36, pls. 1-2).

The coastal plain, which includes the Torrance-Santa Monica area in its western part, is in the Angeles section of the Pacific border province (Fenneman, 1931, p. 493). It is bordered by the Pacific Ocean on the west and south and by the Santa Monica Mountains, the Puente Hills, and the Santa Ana Mountains and their foothills on the north and east (pl. 1).

The dominant landform features of the coastal plain are a central lowland plain with six tongues extending to the coast, bordering highlands and their foothills, and a succession of low hills trending north-westward which separate the main lowland plain and a lesser plain to the southwest. The succession of low hills is the land-surface expression of the Newport-Inglewood uplift—the inland margin of the west basin.

The Torrance-Santa Monica area includes the western part of the main lowland plain and two tongues of this plain which extend to the coast across the Newport-Inglewood uplift. Between these two tongues or gaps and coastward from the uplift is a low plain of marine origin, the Torrance plain, which is flanked on the west by a belt of dune sand fringing the coast. To the north and south are bordering highland areas, the Santa Monica Mountains and the Palos Verdes Hills, respectively.

Excepting the bordering highlands, the total relief in the Torrance-Santa Monica area is about 500 feet from a high point of 513 feet above sea level at the summit of the Baldwin Hills to sea level at Ballona Lagoon, 5 miles distant in the northwestern sector of the area.

The location and extent of the landforms within the western part of the coastal plain are generalized on plate 8; details of their form are shown on the Geological Survey topographic maps of the area.

**BORDERING HIGHLANDS AND ALLUVIAL APRONS**

The highland areas that border the Torrance-Santa Monica area are the eastern part of the Santa Monica Mountains on the north, and the Palos Verdes Hills on the south.

The altitudes of the ridge crests in the eastern part of the Santa Monica Mountains reach a maximum of nearly 1,800 feet about 3 miles north of the project boundary. The highest point in the Palos Verdes Hills is 1,480 feet at San Pedro Hill; below this, 13 wave-cut terraces at altitudes of about 100 to 1,300 feet (Woodring, Bramlette, and Kew, 1946, p. 113-116) represent successive pauses during a long period of uplift, which mostly occurred in late Pleistocene time. The lowest terrace is strongly deformed and rises from about 50 feet above sea level in San Pedro to about 400 feet on the north edge of the hills west of Hawthorne Avenue.

Adjacent to the south flank of the Santa Monica Mountains and westward from the Elysian Hills are two surfaces of alluvial aggradation which have been named the Santa Monica and La Brea plains. These surfaces are considered to be of late Pleistocene age, but they have been extensively modified by the erosion of broad channels in which Recent deposits have been laid down.

These foothill surfaces of aggradation absorb some rainfall and local runoff, and consequently, they contribute to the replenishment of the ground-water supply north of the Baldwin Hills.

**NEWPORT-INGLEWOOD BELT OF HILLS AND PLAINS****HILLS**

The Newport-Inglewood uplift is expressed topographically as a belt of discontinuous low hills that extend from the Santa Monica Mountains southeastward into Orange County. In the Torrance-Santa Monica area this belt is cut by Ballona and Dominguez Gaps near the northwestern and southeastern boundaries.

The uplift and the related plains are underlain at shallow depth, usually less than 30 feet, by a surface of marine planation which was developed upon deformed lower Pleistocene and Tertiary strata. Initially formed in late Pleistocene time, the surface evidently was a plain of low relief. On it were deposited the upper Pleistocene marine Palos Verdes sand and a thin capping of presumed continental origin, where the thickness ranges from 5 to 20 feet. Thus, the present land-surface forms of the belt offer a fairly accurate picture of the deformation since late Pleistocene time. For example, they reveal certain faults that disrupt the land surface and act as subsurface barriers to water movement across the uplift.

Baldwin Hills is the boldest of the uplifts along the belt, with a relief of about 400 feet above the surface of Ballona Gap, adjacent to

the north and a summit 513 feet above sea level. The Beverly Hills, about 4 miles northwest across Ballona Gap, reach an altitude about 200 feet lower than the Baldwin Hills, and have less relief. The surface of the Baldwin Hills is severely dissected by sharply incised valleys; the Beverly Hills have been moderately dissected.

Extending about 8 miles southeastward from the Baldwin Hills to Dominguez Hill, the Rosecrans Hills consist of an irregular low swell about 3 miles wide. The crestal altitude decreases from about 240 feet east of Inglewood to about 100 feet on the north flank of Dominguez Hill. The swell is of deformational origin and is asymmetric, with a steeper slope on the west which is modified by two fault escarpments. The most pronounced escarpment is about 50 feet high and extends about  $2\frac{1}{2}$  miles S.  $25^\circ$  E. from Inglewood. The second escarpment is about  $1\frac{1}{2}$  miles long, also trends S.  $25^\circ$  E., and terminates at the north flank of Dominguez Hill.

Dominguez Hill is a simple elliptical dome 3 miles long and about 195 feet above sea level. Like the Rosecrans Hills, it has a flatter slope on the northeast flank and is deformational in origin; however, it is less modified by stream erosion. Its major axis trends N.  $60^\circ$  W., or about  $20^\circ$  west of the general trend of the belt of hills.

#### RELATED PLAINS

The Ocean Park plain is a comparatively undeformed westward extension of the Beverly Hills; it is immediately south of the Santa Monica plain and north of the coastal part of Ballona Gap. It consists of three subdivisions: (1) a small bench to the east, which is about 190 feet above sea level, (2) an extensive central plain, which slopes gently southward, and (3) a ridge-and-trench area which lies parallel to the coast and is ascribed to upper Pleistocene shoreline features (Hoots, 1931, p. 121).

An extensive counterpart of the Ocean Park plain is the Torrance plain, which stretches from the southwest flank of the Baldwin Hills to Wilmington; its surface is essentially continuous with that of the Rosecrans Hills which flank it on the northeast. This plain is inferred to extend beneath the now inactive dune belt of the El Segundo sand hills along its southwest flank. The Torrance plain is somewhat warped, especially along its inland margin. North of Gardena the warping has formed a shallow depression which has no natural external drainage, and is floored with Recent playa deposits. A more pronounced downwarp occurs at the southwest flank of Dominguez Hill, which is floored with Recent deposits, and represents a northwestward extension of the Downey plain into the Torrance plain.

Under natural conditions the Torrance plain was very poorly drained. Drainage from its northern and central parts was to the

downwarp north of Gardena; drainage from its south-central part was to the downwarp southwest of Dominguez Hill by way of Laguna Dominguez and a small creek trending eastward from Torrance. A small area west of Wilmington drained internally to Bixby Slough. Most of this discontinuous natural drainage has been integrated artificially by the Dominguez Channel, which now receives runoff from 56 square miles upstream from its Carson Street crossing and discharges into the east basin of Los Angeles harbor and thence to San Pedro Bay.

The playa deposits flooring the two natural undrained depressions described above are fine grained and dense. Penetration of rainwater and water from surface runoff through these deposits is slow. On the other hand, water from runoff has collected in these depressions and evaporation has concentrated the total-solids content of the water that has penetrated below land surface. Thus, these downwarps are closely related to the naturally inferior quality of the shallow water in the Gardena area.

#### GAPS

In the Torrance-Santa Monica area the Newport-Inglewood uplift is transected by two tongues of fluvial deposits which extend from the central lowland (Downey plain) to the coast. These tongues occupy two stream-cut erosional gaps which are known as Ballona and Dominguez Gaps. The streams which formed these gaps maintained their courses during the late Pleistocene deformation along the Newport-Inglewood uplift and thus may be classed as antecedent. Both gaps are flanked by stream-cut bluffs, which have greatest relief across the uplift.

Ballona Gap, which is topographically most prominent between the Beverly Hills and the Baldwin Hills, is 1.2 miles wide at its narrowest point and is about 10 miles long from the east end of the Baldwin Hills to Santa Monica Bay. The lower 6-mile segment is within the west basin. Its trench was cut into the upper Pleistocene marine (Palos Verdes) surface by an ancestral westward-flowing Los Angeles River and is floored by Recent alluvial deposits to a depth of 50 feet near the coast and to about 80 feet northeast of the Baldwin Hills, which are about 9 miles upstream.

The stream-cut bluffs flanking Ballona Gap reach a maximum height of 400 feet at the north face of the Baldwin Hills. Although subsequent deformation has altered the profile of the trench in Ballona Gap, the incising stream evidently reached a level at least 50 feet below present sea level at the coast and as much as 400 feet below the upper Pleistocene marine surface at the axis of greatest deformation along the Newport-Inglewood uplift. It is believed that the present Ballona Gap represents an inland segment of the trenching—that is, the incised

stream was graded to a base level substantially more than 50 feet below present sea level and possibly as much as 2 to 3 miles seaward from the present coast. It is possible that Ballona Gap was trenched at essentially the same time as Bolsa Gap in Orange County, which was graded to a base level about 70 feet below sea level, prior to diversion of the Santa Ana River to Santa Ana Gap (Poland, Piper, and others, 1956, p. 44-46). After the ancestral stream in Ballona Gap had incised its channel about 50 feet below present sea level at the coast, presumably during late Pleistocene recession of the seas, its course was diverted southward into Dominguez Gap and was maintained there during the later stages of the pre-Recent gap-cutting cycle.

Dominguez Gap, which passes between Dominguez Hill and the northwestern extension of Signal Hill, is 1.6 miles wide at its narrowest point and is about 7 miles long. It was trenched mainly by an ancestral San Gabriel River, which had a southward-flowing ancestral Los Angeles River as tributary. The highest of the stream-cut bluffs along the gap is at the east face of Dominguez Hill and is about 100 feet high.

Dominguez Gap was eroded to a depth of 150 feet or more below present sea level at the coast, and to about 250 feet below the late Pleistocene surface at the crest of the uplift. The entrenched valley extended inland across the coastal plain to Whittier Narrows, with a tributary trench reaching from Compton to the Los Angeles Narrows. The Recent epoch of aggradation started with the deposition of gravel and coarse sand to a depth of 50 to 70 feet. Subsequently, deposits of silt and fine sand about 75 feet thick were deposited on top of the permeable basal tongue. Thus the trench was backfilled to a thickness of about 150 feet with deposits of Recent age.

#### EL SEGUNDO SANDHILLS

A coastal belt of dunes and sandhills about 11 miles long parallels the shoreline from Ballona escarpment to the Palos Verdes Hills, and extends inland from 3 to 6 miles to overlap the Torrance plain. This belt is a conspicuous topographic feature called the El Segundo sandhills. It may be subdivided into two distinct elements. One element is adjacent to the coast and is about half a mile wide. For the most part, it is made up of dunes with crests ranging from 85 to 185 feet above sea level. These dunes are inferred to be of Recent age. The main part of the belt is from 2 to 5 miles wide, and consists of stabilized dunes and parallel ridges and aligned hills which have been generally interpreted as ancient offshore bars modified by wind and stream action since their emergence from the ocean.

The coastal bar deposits were probably formed during a high level of the seas immediately before the latest Pleistocene withdrawal which instituted the cycle of gap cutting; hence, they are considered to be of late Pleistocene age. The dunes, on the other hand, although probably formed, in part, during the pre-Recent gap-cutting cycle, presumably were formed chiefly during the drier climatic conditions that inferentially accompanied deposition of the later or upper division of the Recent sediments.

#### DOWNEY PLAIN

The western part of the extensive central lowland, or Downey plain, forms the inland border of the Torrance-Santa Monica area. It is the surface formed by alluvial aggradation during the post-Pleistocene epoch of rising base level, and is substantially adjusted in grade to the major streams which enter the coastal plain at the several passes through the bordering mountains and foothills. The alluvial deposits in Ballona and Dominguez Gaps thus represent the coastward extensions of this plain.

Within the project area, the Downey plain and its extension through Ballona Gap is underlain chiefly by the alluvial fan of the Los Angeles River; the apex of this fan is in the Los Angeles Narrows at an altitude of 275 feet. The tongue of the plain extending through Dominguez Gap is largely a part of the San Gabriel River fan, whose apex at Whittier Narrows has an altitude of 200 feet.

Near the inland narrows the alluvial material composing the Downey plain is coarser and highly permeable; these segments constitute important intake areas for the recharge of the principal aquifers beneath the Downey plain and the extensions into the west basin.

#### DRAINAGE

Within the area of investigation the largest stream is the Los Angeles River which passes southward across the Downey plain from the Los Angeles Narrows and discharges into San Pedro Bay through Dominguez Gap. Upstream from the Pacific Coast Highway at Long Beach, it has a drainage area of about 1,060 square miles; almost all the drainage area is inland from the Torrance-Santa Monica area. In 1894 its channel within Dominguez Gap had two distributaries, which branched about 4 miles north of the shore and discharged into the former Wilmington Lagoon (Mendenhall, 1905a, pls. 1 and 4). Within the past two decades, however, the river has been confined in its channel by flood-control levees and now discharges southward directly into San Pedro Bay.

The streams within the coastal plain in Los Angeles County are intermittent; they carry large flows only after heavy winter rains.

Many times in the past flash flows in winter have been too large for the natural channels to carry and have resulted in very destructive floods.

Thirteen major floods were recorded on the Los Angeles and San Gabriel Rivers from 1811 to 1891. For an unknown length of time before 1825, the Los Angeles River flowed westward through Ballona Gap, but during the floods of that year it broke out of its course to drain southward into San Pedro Bay via Dominguez Gap. During the floods of 1862 and 1884, part of the flood waters returned temporarily to Ballona Gap, but since 1884 the Los Angeles River has discharged southward to San Pedro Bay (Troxell and others, 1942, p. 385-391).

The largest flood of the Los Angeles River for which records are available occurred in March 1938. The maximum discharge reached 67,000 cfs at a point a mile upstream from the Main Street bridge in Los Angeles; at Long Beach, where discharge was swelled by the flood waters of the tributary Rio Hondo, a maximum discharge of 99,000 cfs was recorded (Troxell and others, 1942, p. 12 and 246). On the other hand, during the thirties, for as much as 9 months of the year, the recorded flow of the Los Angeles River at Long Beach has been less than 10 cfs; at times in 1929, 1930, and 1934 its channel was dry.

Compton Creek drains an area of some 30 square miles north of Dominguez Hill and east of the Rosecrans Hills. In the middle nineties and for several decades thereafter, it maintained a course southward along the west margin of Dominguez Gap and discharged into San Pedro Bay through the former Wilmington Lagoon. In 1938 part of the upstream channel was paved and the creek was joined to the Los Angeles River about 5.5 miles inland from the coast and about half a mile south of Del Amo Street.

The natural unintegrated drainage pattern within the Torrance plain has been discussed elsewhere (p. 17). Most of the drainage has been integrated artificially by construction of the so-called Dominguez Channel, which discharges into San Pedro Bay.

In the northern part of the area the most important stream is Ballona Creek, whose tributaries drain the northern slopes of the Baldwin Hills, the southern slopes of the Santa Monica Mountains east of Sepulveda Boulevard, and also a large area east and northeast of the Beverly Hills. About 4 miles from the coast, at Sawtelle Boulevard, Ballona Creek has a tributary drainage area of 111 square miles. The creek, which is now paved with concrete except for the 5-mile reach above its mouth, discharges directly into Santa Monica Bay.



Centinela Creek, its source originally in Centinela Spring in what is now the Centinela Park well field of the city of Inglewood, drains the south flanks of the Baldwin Hills and the area southwest of the Hills. The following quotation from a report by Kew (1923, p. 157) is of interest:

Before the city of Inglewood obtained its water supply from wells at the Centinela Spring, a stream carrying one hundred and twenty-five inches of water issued from this spring, and flowed down Centinela Creek, forming these channels, which are now nearly obliterated. During wet weather it was even possible to row a boat up to the spring from Playa del Rey.

Centinela Creek flows northwestward into Ballona Gap, turns southwestward and follows a course nearly parallel to and southeast of Ballona Creek, and then discharges into the coastal marshes.

## GEOLOGIC FORMATIONS AND THEIR WATER-BEARING CHARACTER

### GENERAL FEATURES

In the Torrance-Santa Monica area, a thick section of Tertiary and Quaternary marine and continental sediments has been deposited on a basement complex of pre-Tertiary metamorphic and igneous rocks. The pre-Tertiary rocks, which are essentially non-water-bearing beds, crop out only at the bordering highlands in the northern and southern boundaries of the area, where they have been uplifted by deformational earth movements and exposed by erosion.

The Tertiary rocks are almost entirely of marine origin and range in age from Eocene to Pliocene. They consist of sandstone, siltstone, mudstone, diatomite, and siliceous shale, and are exposed extensively in the Palos Verdes Hills and in the Santa Monica Mountains; they underlie the younger rocks in all the area between these highlands. Within the Torrance-Santa Monica area these Tertiary rocks are penetrated by many oil wells in the several oil fields and by scattered "wildcat" wells. Several of the Tertiary formations are not exposed in the area and are known only from the records of these drilled wells. Except for certain rocks of latest Pliocene age which contain essentially fresh water, the Tertiary rocks contain only saline waters.

The Quaternary rocks contain nearly all the aquifers now tapped by water wells and are chiefly of Pleistocene age; within the west basin deposits of Recent age occur only within the two gaps.

Extensive deposits of coarse gravel and sand of Pleistocene age, amounting to about half the aggregate thickness of the Quaternary rocks, occur beneath nearly the whole project area and are partly exposed on the Baldwin Hills and on the north flank of the Palos Verdes Hills. Within the west basin these coarse deposits are almost entirely of littoral or shallow marine origin. Fine-grained deposits

of sand, silt, sandy clay, and clay, about equal in aggregate thickness to the coarse deposits, commonly overlie them throughout the area. The deposits of finer grain are partly of marine and littoral origin, but to a greater extent are of lagoonal and continental original.

With the exception of the tongues of Recent deposits in the two gaps, the Tertiary and Quaternary rocks have been deformed along the Newport-Inglewood uplift into a succession of anticlines and domes with intervening structural saddles cut by normal and thrust faults arranged en echelon. Flanking this uplift to the southwest and northeast are synclines, where the two systems of rocks attain their greatest thickness. Along the crest of the uplift they are as much as 12,500 feet thick; in the syncline beneath the Torrance plain they are probably as much as 15,000 feet thick; in the syncline to the northeast, beneath the Downey plain, they may exceed 20,000 feet in thickness.

Many of the lithologic and paleontologic data with which the stratigraphic treatment is concerned were obtained from the reports of geologists (Hoots, 1931; Wissler, 1943, p. 210-234; Woodring, 1946) who have carried out detailed investigations in the region; other data were obtained from S. G. Wissler, paleontologist, Union Oil Co.; and from M. L. Natland, paleontologist, Richfield Oil Corp., in connection with stratigraphic correlations and paleontologic information derived from well samples.

The areal distribution of those stratigraphic units which crop out in the area is shown on plate 2. The general subsurface stratigraphic sequence and the structural conditions, based largely on well-log information, are shown on several geologic sections, plates 3-6. A descriptive summary of the rocks in the area, including an appraisal of the water-bearing characteristics of each formation, is presented in table 3. Plate 7 is a stratigraphic correlation chart, showing graphically the relative thicknesses of the formations represented in each of the eight major oil fields in the area (pl. 18). It is in two sections, each trending nearly parallel to the Newport-Inglewood uplift. One is adjacent to the coast and includes a columnar section at the Palos Verdes Hills; the other is aligned along the Newport-Inglewood uplift from the Inglewood field in the Baldwin Hills to the Dominguez field at Dominguez Hill. Except for the section concerned with the Baldwin Hills, the data for this chart have been compiled largely from information supplied by S. G. Wissler and are based almost entirely upon micropaleontologic correlations supplemented by electric-log data.

TABLE 3.—Stratigraphy of the Torrance-Santa Monica area, California

| Geologic age       | Formation and symbol on plate 2                                                | Thick-ness (feet)                                                                                                   | Physical character                                                                                                                                                                                                                                                                                                                   | Ground-water conditions                                                                                                                                                                                                                                                                                                                                                                                                                                                                     |                                                                                                                                                                                                                                                                                                                                                                                                                                                                                                                                                                                                                      |
|--------------------|--------------------------------------------------------------------------------|---------------------------------------------------------------------------------------------------------------------|--------------------------------------------------------------------------------------------------------------------------------------------------------------------------------------------------------------------------------------------------------------------------------------------------------------------------------------|---------------------------------------------------------------------------------------------------------------------------------------------------------------------------------------------------------------------------------------------------------------------------------------------------------------------------------------------------------------------------------------------------------------------------------------------------------------------------------------------|----------------------------------------------------------------------------------------------------------------------------------------------------------------------------------------------------------------------------------------------------------------------------------------------------------------------------------------------------------------------------------------------------------------------------------------------------------------------------------------------------------------------------------------------------------------------------------------------------------------------|
| QUATERNARY         | Recent                                                                         | Alluvial, coastal, and dune deposits (Qal, Qs)                                                                      | 0-175                                                                                                                                                                                                                                                                                                                                | Beneath the Downey plain and its coastward extensions, Dominguez and Ballona Gaps, unconsolidated silt, gravel, and sand of fluvial origin; coarser materials predominant in lower half of the deposit. Beneath the coastal tide-lands, silt and clay of lagoonal and fluvial origin overlying and enclosing tongues of fluvial sand and gravel. Locally along the coast, accretional beach deposits. Beneath the El Segundo sand-hills, dune deposits, designated on pl. 2 by symbol (Qs). | Beds of gravel and coarse sand in the lower part of the deposit contain confined water and yield water freely to many wells, especially in tongues extending from Whittier Narrows through Dominguez Gap and from Los Angeles Narrows through Ballona Gap. This water is of good chemical quality inland, but moderately to highly saline from the coast inland about 7 miles in Dominguez Gap and about 6 miles in Ballona Gap. Near the coast, tongues and beds of fine sand, and some of fine gravel, in the upper part of the deposit, contain unconfined semiperched water that is moderately to highly saline. |
|                    | Unconformity                                                                   |                                                                                                                     |                                                                                                                                                                                                                                                                                                                                      |                                                                                                                                                                                                                                                                                                                                                                                                                                                                                             |                                                                                                                                                                                                                                                                                                                                                                                                                                                                                                                                                                                                                      |
|                    | Pleistocene                                                                    | Terrace cover and Palos Verdes sand (Qpu); not differentiated on map from unnamed deposits below.                   | 0-50                                                                                                                                                                                                                                                                                                                                 | Reddish-brown sand, silt, and soil, chiefly non-marine in origin; underlain locally by a deposit of fossiliferous sand and gravel of marine origin, the Palos Verdes sand; together these mantle the hills and mesas of the Newport-Inglewood uplift.                                                                                                                                                                                                                                       | Chiefly above the water table and therefore un-saturated; sufficiently permeable to transmit some water from rainfall to underlying materials.                                                                                                                                                                                                                                                                                                                                                                                                                                                                       |
|                    |                                                                                | Unnamed upper Pleistocene deposits (Qpu); not differentiated on map from Palos Verdes sand and terrace cover above. | 0-400(?)                                                                                                                                                                                                                                                                                                                             | Silt, clay, and some gravel, of fluvial and marine origin; in the central part of the west basin, the lower portion contains an extensive body of sand, with some gravel.                                                                                                                                                                                                                                                                                                                   | Beds of gravel and sand hold confined and unconfined water and supply small domestic and stock wells and some larger irrigation wells. This water is of good quality within the Torrance-Inglewood subarea, except locally at shallow depth, and along the coast from El Segundo to Redondo Beach, where it is contaminated. This water is of good quality inland from the Newport-Inglewood uplift.                                                                                                                                                                                                                 |
| Local unconformity |                                                                                |                                                                                                                     |                                                                                                                                                                                                                                                                                                                                      |                                                                                                                                                                                                                                                                                                                                                                                                                                                                                             |                                                                                                                                                                                                                                                                                                                                                                                                                                                                                                                                                                                                                      |
|                    | San Pedro formation, including Timms Point silt and Lomita marl members (Qsp). | 0-1,000                                                                                                             | Unconsolidated to semiconsolidated gravel, sand, silt, and clay; chiefly marine, beach, and lagoonal deposits within the west basin, but largely of fluvial origin inland from the Newport-Inglewood uplift; the coarser materials more plentiful in the lower two-thirds of the deposit. At some places, silt and clay predominate. | Beds of gravel and coarse sand, most commonly in lower two-thirds of deposit, hold confined water and yield copiously to many wells. This water is of good chemical quality inland from the Newport-Inglewood uplift, also on coastal side of uplift in the west basin, except along and near the coast from Santa Monica to Redondo Beach. This formation is the principal source of water within the west basin.                                                                          |                                                                                                                                                                                                                                                                                                                                                                                                                                                                                                                                                                                                                      |

|              |                                                                                 |                     |                                                                                                                        |                                                                                                                                |                                                                                                                                                                                                                                                                                             |                                                                                                                                                                                                                                                                                                                                                                                                                                                                                                                                                                                                                                                                  |
|--------------|---------------------------------------------------------------------------------|---------------------|------------------------------------------------------------------------------------------------------------------------|--------------------------------------------------------------------------------------------------------------------------------|---------------------------------------------------------------------------------------------------------------------------------------------------------------------------------------------------------------------------------------------------------------------------------------------|------------------------------------------------------------------------------------------------------------------------------------------------------------------------------------------------------------------------------------------------------------------------------------------------------------------------------------------------------------------------------------------------------------------------------------------------------------------------------------------------------------------------------------------------------------------------------------------------------------------------------------------------------------------|
| TERTIARY     | Pliocene                                                                        | Pico formation (Tu) | Local unconformity                                                                                                     |                                                                                                                                |                                                                                                                                                                                                                                                                                             | <p>Beds of sand and gravel in the upper part of the deposits contain confined water and locally might yield freely to wells. This water is soft and low in dissolved solids, but is dark brown and has a temperature of about 100° F. Beds of fine sand in the lower part of the deposits are fairly permeable but have not been tapped by water wells. This water is essentially fresh although total dissolved solids content may be too high for domestic use and for irrigation.</p> <p>Largely impervious; if water-bearing, the sandy members contain connate waters whose salinity ranges from about half that of ocean water to that of ocean water.</p> |
|              |                                                                                 |                     | Upper division                                                                                                         | 0-1,800                                                                                                                        | Semiconsolidated sand, silt, clay, and some fine gravel, chiefly of marine origin. Tongues of fluvial(?) sand and fine gravel—the gravel beds north of the Newport-Inglewood uplift and in the upper third of the deposit, the sand layers commonly in the lower two-thirds of the deposit. |                                                                                                                                                                                                                                                                                                                                                                                                                                                                                                                                                                                                                                                                  |
|              |                                                                                 |                     | Local unconformity                                                                                                     |                                                                                                                                |                                                                                                                                                                                                                                                                                             |                                                                                                                                                                                                                                                                                                                                                                                                                                                                                                                                                                                                                                                                  |
|              |                                                                                 |                     | Middle division                                                                                                        | 0-1,240                                                                                                                        | Olive to dark-brown massive claystone and siltstone, fine to coarse gray sand; <sup>1</sup> all of marine origin.                                                                                                                                                                           |                                                                                                                                                                                                                                                                                                                                                                                                                                                                                                                                                                                                                                                                  |
|              |                                                                                 |                     | Local unconformity                                                                                                     |                                                                                                                                |                                                                                                                                                                                                                                                                                             |                                                                                                                                                                                                                                                                                                                                                                                                                                                                                                                                                                                                                                                                  |
|              | Lower division                                                                  | 0-470               | Fine to coarse gray sand, occasionally pebbly, brown sandy siltstone and claystone; <sup>1</sup> all of marine origin. |                                                                                                                                |                                                                                                                                                                                                                                                                                             |                                                                                                                                                                                                                                                                                                                                                                                                                                                                                                                                                                                                                                                                  |
| Miocene      | Repetto formation                                                               |                     | 0-4,080                                                                                                                |                                                                                                                                |                                                                                                                                                                                                                                                                                             |                                                                                                                                                                                                                                                                                                                                                                                                                                                                                                                                                                                                                                                                  |
|              | Local unconformity                                                              |                     |                                                                                                                        |                                                                                                                                |                                                                                                                                                                                                                                                                                             |                                                                                                                                                                                                                                                                                                                                                                                                                                                                                                                                                                                                                                                                  |
|              | Monterey shale, at least in part (Puente formation of Wissler and others) (Tu). |                     | 0-4,500                                                                                                                | Fine to coarse-grained gray sandstone; sandy micaceous siltstone; bluish-gray to dark-brown platy shale; all of marine origin. |                                                                                                                                                                                                                                                                                             |                                                                                                                                                                                                                                                                                                                                                                                                                                                                                                                                                                                                                                                                  |
| JURASSIC (?) | Unconformity                                                                    |                     |                                                                                                                        |                                                                                                                                |                                                                                                                                                                                                                                                                                             |                                                                                                                                                                                                                                                                                                                                                                                                                                                                                                                                                                                                                                                                  |
|              | Franciscan(?) formation                                                         |                     |                                                                                                                        | Greenish, grayish, or bluish serpentine, talc, or schist. <sup>1</sup>                                                         |                                                                                                                                                                                                                                                                                             |                                                                                                                                                                                                                                                                                                                                                                                                                                                                                                                                                                                                                                                                  |
|              |                                                                                 |                     |                                                                                                                        |                                                                                                                                | Impervious, nonwater-bearing.                                                                                                                                                                                                                                                               |                                                                                                                                                                                                                                                                                                                                                                                                                                                                                                                                                                                                                                                                  |

<sup>1</sup> After Wissler (1943, p. 210).

In the following paragraphs the formations are discussed in order from youngest to oldest, thereby giving early emphasis to rocks which are of greater importance from a standpoint of ground-water resources. Those rocks of Tertiary age that contain connate saline ground waters are discussed briefly because their waters are a potential source of contamination of the fresh-water body in the younger rocks.

#### QUATERNARY SYSTEM

##### RECENT SERIES

##### DEFINITION AND GENERAL FEATURES

The deposits of Recent age comprise chiefly the youngest unconsolidated materials formed during the present cycle of alluviation by streams, materials associated with shoreline features, including lagoonal, littoral, and dune deposits, also slope-wash and playa deposits of minor extent.

With respect to water-bearing character, the most important deposits of Recent age are those of fluvial origin. They consist of sand, gravel, silt, and clay, and underlie the Downey plain and its tongues, which extend to the coast through the gaps cut in the older rocks (pl. 2). Thus, the top of the Recent deposits is the surface of the Downey plain and its extensions into the several gaps; their base is the former land surface that had been produced by deformation and trenching of the coastal plain in late Pleistocene time.

In Ballona and Dominguez Gaps and inland from the gaps, logs of many wells which have been drilled through the Recent deposits reveal that the relatively fine grained sediments in the upper few tens of feet commonly are underlain by much coarser materials—chiefly coarse sand to cobble gravel, which have been deposited as tongues many miles in length. These important aquifers, which underlie Ballona and Dominguez Gaps, extend inland across the coastal plain; the textural difference between them and the overlying finer grained sediments provides a basis for separation of the Recent alluvial deposits of the area into an upper and a lower division.

Within the coastal plain as a whole, and for almost all the deposits of Recent age except those within Ballona Gap, the report on the geology of the Long Beach-Santa Ana area has treated in considerable detail their physical character, mode of origin, and general water-bearing character (Poland, Piper, and others, 1956, p. 40-52). Accordingly, the treatment in the following paragraphs will summarize the character of these deposits briefly, with emphasis on the two basal aquifers of the lower division which extend across the west basin in Dominguez and Ballona Gaps, and which respectively constitute the Gaspur water-bearing zone and the "50-foot gravel."

## UPPER DIVISION

*Flood-plain deposits.*—Some of the most widely distributed deposits in the upper division of Recent age in the Torrance-Santa Monica area are the alluvial-fan and flood-plain sediments laid down at times of excessive runoff, when the streams overflowed their banks and spread widely over their alluvial fans. These sediments are largely fine sand and silt, with lesser amounts of clay and gravel. The finer sediments have been widely distributed over the coastal flood plains; the sand and gravel have been laid down chiefly on the steeper inland slopes of the alluvial fans and within the larger channels. In the present climatic period, which probably existed throughout the deposition of the upper division of the Recent series, this type of alluviation has been the common pattern. However, because of the increased development of the coastal plain and the construction of engineering works designed to control flood runoff, in recent years the streams have overflowed their banks and deposited sediment over their natural flood plains only during the largest floods.

These deposits of the upper division are distributed beneath all the Downey plain, in the two gaps within the project area, and in local areas tributary to these gaps. Their thickness is as much as 100 feet in the central part of the Downey plain; in Dominguez Gap it ranges from 45 to nearly 80 feet; but in Ballona Gap, where the Recent series as a whole is thinner, the upper division is from 10 to 50 feet thick. In the reach between Dominguez and Ballona Gaps these sediments feather out along the inland flank of the Newport-Inglewood belt of hills. The top of these deposits is the surface of the Downey plain. Within the extent of the lower division of the Recent, the base of the upper division rests almost conformably on the top of these coarser tongues; elsewhere their base is the modified lower Pleistocene land surface.

*Minor deposits.*—The upper division of the Recent series also contains minor deposits which include slope-wash, playa, lagoonal, beach, and dune deposits. With the exception of the beach deposits, these have relatively little importance from the standpoint of this investigation.

The slope-wash and playa deposits probably do not measure more than a few feet in thickness in any part of the area. The former are mainly weathered rock fragments, fine sand, and silt, developed on hill slopes; the latter have accumulated in undrained depressions in or near the Torrance plain (p. 17), and consist of silt and clay of local origin.

The lagoonal marshes, which were formerly behind the barrier beaches at the mouths of Ballona and Dominguez Gaps, have acted as sedimentation basins for some of the load carried by streams dur-

ing intermittent floods. Thus, they have received contributions of fine sand, silt, and clay, which have become interbedded with the organic debris native to the marshes.

Recent beach deposits form narrow arcuate strips of sand and gravel, which flank Santa Monica and San Pedro Bays, fringe the coastal wavecut sea cliffs and connect across the gaps by barrier beaches. These beach deposits have been the chief source of material supplied to the coastal-dune belt.

With regard to saline contamination from the ocean, these beach deposits are of great interest because: (1) at least locally along the coast, they are believed to extend for several tens of feet below sea level; (2) probably they are in direct contact with the Silverado water-bearing zone in the vicinity of Redondo Beach and with the "50-foot gravel" and the main water-bearing zone of the San Pedro formation at the mouth of Ballona Gap; and (3) they are highly permeable. Thus, under the current conditions of landward hydraulic gradient, these beach deposits probably afford conduits for the movement of ocean water into the coastal margins of the main water-bearing zones within the west basin.

The dune deposits that underlie the El Segundo sandhills are formed almost entirely of fine- to medium-grained sand of uniform texture. They range in thickness from a featheredge to as much as 150 feet. As exposed in an excavation at Hyperion (in 2/15-10), they exhibit several stages of dune formation, with dense cemented layers now buried, which probably represent former land surfaces. These dune deposits mantle an area of about 35 square miles along the southwest flank of the Torrance plain. They are almost entirely above the zone of saturation and thus do not yield water to wells. However, they are relatively permeable and transmit substantial quantities of water from rainfall to the underlying Pleistocene rocks. Where those rocks are impermeable, doubtless a water table occurs within the dune deposits. Also, the denser layers within the dunes may develop perched water bodies of local extent.

#### LOWER DIVISION

The deposits of the lower division of Recent age do not crop out in the area and consequently are known only from logs of wells and from samples taken during drilling. These indicate that the lower division consists almost entirely of coarse sand and gravel, deposited in tongues. In the Torrance-Santa Monica area, the two principal tongues are the Gaspar water-bearing zone in Dominguez Gap and the "50-foot gravel" in Ballona Gap. Physical connection between these two zones is afforded by the so-called westerly arm of the Gaspar zone, which extends southward from the Los Angeles Narrows

to about a mile east of Compton, where it joins the Gaspur water-bearing zone (pl. 8).

*Gaspur water-bearing zone.*—The Gaspur water-bearing zone was deposited in early Recent time by an ancestral San Gabriel River, with minor contributions from an ancestral Los Angeles River in the reach coastward from their junction near Compton.

The Gaspur water-bearing zone has been traced for more than 20 miles across the Downey plain from Terminal Island to Whittier Narrows, as shown in an earlier report (Poland, Piper, and others, 1956, pl. 7). Doubtless it extends northward into San Gabriel Valley and southward beneath San Pedro Bay. The maximum width of 4 miles occurs just south of Downey. Within the area covered by this report it is relatively narrow, being about a mile wide at the eastern salient of Dominguez Hill, but increasing somewhat in width to the north and south (pl. 8).

The thickness of the Gaspur zone ranges from 50 to 75 feet. Near the coast, its base has a gradient of about 9 feet per mile, from about 70 feet below sea level 2 miles north of Dominguez Gap to 150 feet below sea level at the coast. The gradient steepens somewhat to the northeast so that, reckoned from Whittier Narrows, where the base of the zone is 100 feet below the land surface and 90 feet above sea level, the average gradient to the coast is about 12 feet per mile.

Typical deposits of the Gaspur zone are indicated by the log of well 4/13-15A11 (table 28). The zone generally is characterized by a lower part consisting of coarse clean gravel from 25 to 50 feet thick, containing cobbles as much as 6 inches in diameter, overlain by an upper part of medium to coarse sand from 20 to 50 feet thick. However, there is considerable lithologic variation and this typical disposition of the gravel and sand is best developed southward from the middle of the Downey plain. Beneath the inland part of the Downey plain both the main Gaspur zone and the westerly arm become coarser and contain more gravel and less sand; neither the gravel nor the sand lie in a characteristic stratigraphic position.

*Westerly arm of the Gaspur water-bearing zone.*—A tributary branch of the Gaspur water-bearing zone, the deposit of an ancestral Los Angeles River, here called the "westerly arm" of the Gaspur water-bearing zone, has been traced from the Los Angeles Narrows southward and roughly parallel to Alameda Street for about 11 miles to its junction with the main Gaspur zone about a mile east of Compton. The thickness of this westerly arm ranges from 30 to 80 feet; its average width is about 2 miles and its gradient from the south edge of the Los Angeles Narrows to the junction with the Gaspur water-bearing zone is about 20 feet to the mile, although in the 3 miles immediately north of the junction near Compton the gradient is only about 15



feet per mile. At the junction, the Gaspar zone and its westerly arm have a common base 140 feet below the land surface, or 70 feet below sea level. This westerly arm is somewhat coarser in composition than the deposits of the Gaspar zone in Dominguez Gap; it is similar to the gravel found in the main tongue of the Gaspar zone from the middle of the Downey plain to Whittier Narrows. Sand and minor quantities of clay are interspersed irregularly with the gravel in this westerly arm.

*"Fifty-foot gravel."*—In Ballona Gap, the lower division of the Recent series is represented by a relatively thin and irregular gravel body which was laid down by an ancestral Los Angeles River. In the area of its most characteristic development, between Culver City and the coast, its base ranges from 40 to 80 feet below the land surface, but its average depth is about 50 feet below the surface. For this reason the name "50-foot gravel" has been assigned for the purposes of this report. By means of well logs it has been traced inland beyond the narrows between the Baldwin and the Beverly Hills to its junction with the westerly arm of the Gaspar water-bearing zone, south of the La Brea plain and in the vicinity of Vermont Avenue (pl. 8).

The "50-foot gravel" ranges in thickness from 10 to 40 feet and consists generally of coarse gravel and a subordinate amount of sand. Its average thickness is only about a third as great as that of the Gaspar water-bearing zone in Dominguez Gap.

Logs of wells show that the depth to the base, position, and thickness of the "50-foot gravel" are very irregular. Thus, although the overall seaward gradient of the base of the "50-foot gravel" from northeast of the Baldwin Hills to the coast is about 8 feet per mile, that gradient has been estimated by taking an average altitude of the base from well logs that show substantial variation within short distances. Other well logs show only clay or sandy clay (silt) in the depth range where the gravel would be expected to be present. The discontinuity and irregularity in thickness and position of the "50-foot gravel" suggest that (1) it was deposited on an uneven base which may have contained both channels and terrace remnants, and (2) the backfilling was accomplished by a stream with insufficient transporting power to lay down a broad sheet of gravel across the full width of the gap. Also, during this backfilling stage, the tributary streams that discharged southward to Ballona Gap across the dissected Santa Monica plain may have been building debris cones along the north side of the gap. Those cones would doubtless have contained materials of substantially finer grain than the coarse sediments transported by an ancestral Los Angeles River.

As determined from well logs, west of the Baldwin Hills the transverse profile of the base of the "50-foot gravel" dips southeastward across Ballona Gap. The lowest part of the gravel generally is beneath or south of the present course of Ballona Creek; the altitude of the base at that point is about 40 feet lower than on the northwest side of the gap. This feature suggests that southward tilting of the "50-foot gravel" has occurred. If such is the case, the essentially straight alinement of the Ballona escarpment west of the Baldwin Hills may in part represent a fault scarp that has been modified to some degree by stream erosion. The substantial difference in chemical character of the native waters within the San Pedro formation to the north and south of this escarpment (pl. 19) might be interpreted as supporting this inference. Hydrologic evidence gives no clue in regard to the presence of a ground-water barrier along the escarpment.

#### WATER-BEARING CHARACTER

*Upper division.*—Because it is composed chiefly of materials of fine texture and low permeability, the upper division of the Recent is tapped by only a very few small domestic wells. It is sufficiently permeable, however, to absorb a moderate volume of water by infiltration of rain, by percolation from the streams—the Los Angeles River and Compton and Ballona Creeks—and by deep penetration of irrigation water. Most of this water first reaches the unconfined semiperched water body and ultimately is transmitted to the coarse tongues of the lower division—the Gaspur water-bearing zone and the "50-foot gravel."

*Gaspur water-bearing zone.*—The character of the Gaspur water-bearing zone has been discussed at length in a report by Poland (1959), and will be only briefly summarized here. The Gaspur zone is highly permeable and is tapped by wells throughout its 21-mile reach from Terminal Island to Whittier Narrows. However, for its extent within the west basin—from the coast inland some 6 miles to Del Amo Street—the zone has been contaminated by saline waters and in most of this area its water is unfit for use. Yield data are available for five wells in this coastal area. Their yield ranges from 210 to 1,500 gpm. For four of these wells, the average specific capacity (gallons per minute per foot of drawdown) is 63. Data available from pumping tests suggest that within this reach the permeability of the Gaspur zone ranges from 3,000 to 5,000 gpd per square foot.

*"Fifty-foot gravel."*—During the early development of ground water in Ballona Gap, the "50-foot gravel" was tapped by several scores of wells for domestic, irrigation, and stock use. Because of the decline in water levels, this water-bearing zone has been dewatered beneath a large part of the gap. Also, its water has become contaminated

within much of its extent coastward from the Inglewood fault. Hence, most of the wells, which currently withdraw water for irrigation or other uses, tap the underlying deposits of the San Pedro formation.

Fragmentary data on yields from wells tapping the "50-foot gravel" indicate that they have ranged from less than 100 to as much as 800 gpm. No information on specific capacity is available. However, because the "50-foot gravel" is only about one-third to one-half as thick as the Gaspar water-bearing zone, the yields indicate that the permeability may be about the same.

#### PLEISTOCENE SERIES

##### GENERAL FEATURES

Deposits of Pleistocene age crop out over nearly all of the Newport-Inglewood belt of hills, over the Torrance plain and the Ocean Park plain, and locally on the flanks of the Santa Monica Mountains and the Palos Verdes Hills. They are overlain by alluvial deposits in the gaps and by beach and dune deposits along the coast, and are underlain by Pliocene and older rocks. These Pleistocene deposits are chiefly unconsolidated and consist of interlensing beds of sand, gravel, silt, and clay. In downward succession they include a capping terrace deposit, the Palos Verdes sand, certain unnamed upper Pleistocene deposits, and the San Pedro formation of lower Pleistocene. In the area shown on plate 2 the San Pedro formation is the thickest of the Pleistocene deposits.

Along the coast, the Pleistocene rocks range in thickness from about 100 to 600 feet; in the syncline southwest of Dominguez Hill their thickness is as much as 1,200 feet. Along the crest of the Newport-Inglewood zone their thickness ranges from a feather edge at the Baldwin Hills to 700 feet at the southeast edge of Dominguez Hill. Inland beyond that zone they attain a maximum thickness of about 3,000 feet beneath the central Downey plain and become thinner northward and northeastward toward the inland hills, where they have been faulted, warped upward on anticlinal uplifts, and partly removed by erosion.

##### TERRACE COVER AND PALOS VERDES SAND

The Newport-Inglewood belt of hills, the Torrance and Ocean Park plains, and parts of the bordering highland areas are capped by a terrace cover of nonfossiliferous red sand and silty sand. In most of the area, this cover ranges from a few feet to about 20 feet in thickness. It owes its characteristic red color to iron oxide derived from the processes of weathering.

In the Palos Verdes Hills, according to Woodring (1946, p. 106), the thickness of the cover toward the rear of one terrace "is as much

as 100 feet, but an exposed thickness greater than 50 feet is exceptional." The deposits there represent "cliff talus rubble, stream fan and channel material, and rill and slope wash," and in places the remains of land mammals have been reported. These deposits, therefore, are definitely continental in origin. Davis (1933, p. 1055-1056, 1058-1061, figs. 5 and 6) describes the origin and physiographic aspects of similar deposits along the Santa Monica Mountains.

At some places, the relatively thin terrace cover over the Newport-Inglewood zone and the Torrance plain may be of flood-plain origin and may have been formed immediately after emergence of the upper Pleistocene marine surface. But elsewhere the true nonmarine cover may be absent, the red zone being merely the upper few feet of the marine Palos Verdes sand, which has been modified by weathering.

Hoots (1931, p. 120-123, 130) describes alluvial deposits of late Pleistocene age which cap the dissected Santa Monica plain. "These deposits range in thickness from a few feet to at least 200 feet" and are composed of dark brown poorly sorted angular rock fragments "embedded in a soft matrix of reddish-brown clay and sand." Locally they "rest directly upon a slight thickness of horizontal fossiliferous marine upper Pleistocene deposits." Thus, although in places they are considerably thicker than the terrace cover, which occurs farther south, these deposits may in large part be stratigraphically equivalent to that cover.

At several exposures along and near the Newport-Inglewood structural zone, the nonmarine terrace cover is underlain by a thin layer of fossiliferous gray sand and gravel. First described under the name "upper San Pedro series" and later called the "Palos Verdes formation," this stratigraphic unit has recently been defined by Woodring (1946, p. 56) as the Palos Verdes sand; he describes its typical characteristics as it occurs in the Palos Verdes Hills as follows:

The Palos Verdes sand like the older marine terrace deposits, consists of a thin veneer on the terrace platform, which bevels formations ranging in age from lower Pleistocene to Miocene. Also like the older marine terrace deposits, the strata consist generally of coarse-grained sand and gravel but include silty sand and silt. Limestone cobbles are the prevailing constituent of the gravel, granitic and schist pebbles being locally abundant. The thickness of the Palos Verdes generally ranges from a few inches to 15 feet and is usually less than 10 feet. At places it consists of thin lenses, and at other places it is absent.

According to Woodring, faunal evidence indicates that the Palos Verdes sand is of late Pleistocene age. The lowest, and youngest, marine terrace of the Palos Verdes Hills on which it is deposited presumably is a correlative of the upper Pleistocene marine platform that underlies the Torrance plain and the Newport-Inglewood belt of hills at shallow depth, and which prior to deformation was of very low relief.

Outside the Palos Verdes Hills, the Palos Verdes sand or its essential stratigraphic equivalent has been identified at several localities. Among those in or near the Torrance-Santa Monica area, the following are pertinent:

1. About 6 miles west of Long Beach and 200 feet south of the intersection of Sepulveda Boulevard and Vermont Avenue, a thin lens of gray sand containing marine shells is exposed beneath red soil. On the basis of the megafossils, this sand has been identified by Woodring (personal communication, Nov. 23, 1943) as the essential equivalent of the Palos Verdes sand.

2. A trench dug on the northeast side of the Baldwin Hills about 1925, for the Los Angeles Outfall Sewer, exposed a section, which Tiejé (1926, p. 502-503) described as 50 feet of massive grayish green very coarse to gravelly quartzose and loosely cemented sands. He called these the "Palos Verdes sands."

3. About 2 miles northeast of Playa del Rey, at the Ballona escarpment, the Palos Verdes sand has been exposed by the widening of Lincoln Boulevard where it begins to decline onto Ballona Gap. Beneath a thin soil cover, reddish-brown sand 10 feet thick is underlain by 10 feet of clay, which in turn is underlain by 15 feet of medium to coarse brown sand. The lower 6 feet of this sand layer contains abundant shell remains. From a study of this fauna, Willett (1937, p. 379-406) has correlated the enclosing sand as the stratigraphic equivalent of the Palos Verdes sand at the Baldwin Hills locality described by Tiejé and cited above. About 20 feet of light-brown sand, which is presumed to be part of the San Pedro formation of early Pleistocene age, is exposed beneath this Palos Verdes sand.

4. Just outside the area, about 2 miles northwest of the city of Santa Monica, sands of "upper San Pedro" (Palos Verdes) age are exposed in Potrero Canyon. Woodring, quoted by Hoots (1931, p. 122), believes that these sands "probably correspond to the sands of the Baldwin Hills section described by Tiejé as the Palos Verdes sands."

5. The Ocean Park plain and the Beverly Hills are underlain by "soft sand, clay, gravel, and conglomerate," which are considered by Woodring (Hoots, 1931, p. 121), from faunal evidence, probably to represent "upper San Pedro" (Palos Verdes) age. Hoots reports that the only fossils found in the area were from a stream-cut bluff at the north edge of Ballona Gap, where a cut bank on the west side of Overland Avenue and about 200 feet south of the crest of the hill exposes a bed about 10 feet below land surface consisting of dark reddish-brown sandy silt and containing shells. This shell bed is overlain by brown massive silt extending to the land surface. These

upper Pleistocene marine sediments in places underlie the Pleistocene alluvial deposits which form the Santa Monica plain.

Because the main water-bearing zones of the west basin occur at depths usually in excess of 150 feet below the land surface, the shell bed that commonly marks the base of the Palos Verdes sand is not often logged by drillers. A bed containing oyster shells at a depth of 18 feet, a foot of white sand to 19 feet, and a thin "coral" bed—evidently a hard-shell bed—was found in a well about 2 miles north of Torrance, in 3/14-34. It is presumed that these shell beds are at the base of the Palos Verdes sand, and that this formation occurs here to a depth of about 20 feet below the land surface.

For a description of the correlatives of the Palos Verdes sand as it occurs in the adjacent Long Beach-Santa Ana area to the east and southeast, the reader is referred to an earlier report (Poland, Piper, and others, 1956, p. 52-55).

A detailed account of its occurrences in the type locality, including faunal lists, is presented in the report by Woodring, Bramlette, and Kew (1946, p. 56-59) on the Palos Verdes Hills.

Along the Newport-Inglewood uplift, the terrace cover and the Palos Verdes sand are almost entirely above the water table and therefore they are unsaturated. At places beneath the Torrance plain the Palos Verdes sand is below the semiperched water table and is sufficiently permeable to yield water to shallow wells, although this water commonly is of inferior quality. Where these deposits form the land surface, they are sufficiently permeable to absorb some water from rainfall and to transmit it to underlying deposits.

Although the Palos Verdes sand has little importance as an aquifer, it is of critical importance in establishing the amount of deformation of the Pleistocene water-bearing deposits in latest Pleistocene time. Therefore, its known occurrences within the Torrance-Santa Monica area have been described in some detail in the preceding paragraphs.

#### UNNAMED UPPER PLEISTOCENE DEPOSITS

##### DEFINITION AND EXTENT

In an earlier report by the Geological Survey (Poland, Piper, and others, 1956, p. 55-57), certain strata of late Pleistocene age found in wells between definite or probable correlatives of the Palos Verdes sand above and the San Pedro formation below have been designated "unnamed upper Pleistocene deposits." These deposits underlie much of the Torrance-Santa Monica area and are described in following paragraphs.

In water well 3/13-32F6, near the intersection of Victoria Street and Avalon Boulevard and low on the west flank of Dominguez

Hill, two zones of marine shells were reported—one in sand 20 to 30 feet below the land surface and the other from 238 to 260 feet. The upper shell zone is inferred to represent the Palos Verdes sand, and the lower one the megafossil zone near the top of the San Pedro formation of lower Pleistocene age; the material between these two shell zones has been assigned to the unnamed upper Pleistocene deposits.

About a mile to the east and near the intersection of Victoria Street and Central Avenue on Dominguez Hill, oil wells are reported by Wissler (1943, p. 212) to pass through: (1) nonmarine yellow and brown sand, sandy clay, and gravel to 175 feet below land surface; (2) lagoonal deposits 40 feet thick; (3) a thin deposit of lignite; and (4) about 300 feet of marine sand and gravel, including a megafossil zone, San Pedro in age, from 215 to 250 feet below land surface. Wissler has concluded that the top 175 feet of nonmarine sediments are of late Pleistocene age, and he assigns the lagoonal deposits and the marine sand and gravel to the San Pedro formation. It is inferred that the nonmarine beds from about 30 to 175 feet below land surface represent the unnamed upper Pleistocene deposits.

Natland examined samples collected during the drilling of well 4/13-22D1, about 3 miles south of Dominguez Hill. He reported that samples taken to a depth of 164 feet were nonfossiliferous and that samples below this depth contained fossils (Natland, M. L., written communication, 1943). From this report and other evidence, it is inferred that the upper 30 feet of deposits are of Recent age; those from 30 to 164 feet are believed to represent the unnamed upper Pleistocene deposits.

By means of peg-model studies, the unnamed upper Pleistocene deposits have been tentatively correlated over most of the southern part of the Torrance-Santa Monica area. These sediments extend at least as far north as the Ballona escarpment and southward to the Palos Verdes Hills. Between these north-south limits they extend from the coast over the crest of the Newport-Inglewood structural zone, and inland beneath the Downey plain. They have not been traced beneath Ballona Gap and to the north, although their stratigraphic equivalent may be present; apparently they are absent beneath the Baldwin Hills.

#### PHYSICAL CHARACTER AND THICKNESS

The unnamed upper Pleistocene deposits vary considerably in lithology, both vertically and laterally. Nevertheless, the upper half of the deposits is generally fine grained, chiefly silt, clay, and sand. The lower half is chiefly sand, containing some gravel and subordinate amounts of silt and clay. Because of its coarse texture,

this lower stratum is a productive aquifer in much of the Torrance-Inglewood subarea. Its midposition is about 200 feet below the land surface in the area of its most typical occurrence—in the broad syncline extending from Inglewood southeastward through Gardena. Hence, it has been named the “200-foot sand” for purposes of this report.

Although the “200-foot sand” is composed chiefly of sand, logs of wells reveal much variation in its physical character from place to place. Thus, well 3/14-23L1, about a mile north of Gardena and near the synclinal axis, is reported to have cut through 332½ feet of clay, beneath a surface alluvial sand 1½ feet thick, before striking an aquifer in the San Pedro formation. Here the “200-foot sand” apparently is wholly absent. At well 3/14-22A1 (for log, see table 28), also near the axis of the syncline, the “200-foot sand” is represented by an upper sandy zone, a middle clayey zone, and a lower sandy zone. Many well logs indicate that the “200-foot sand” is locally a coarse gravel, as at well 2/14-27J1 (table 28), situated on the crest of the Newport-Inglewood uplift at the north end of the Rosecrans Hills. The “200-foot sand” is also largely gravel beneath an area of about 4 square miles near the coast, at and near the city of El Segundo and the Standard Oil Co. well fields in secs. 12 and 13, T. 3 S., R. 15 W., and beneath about 7 square miles in the vicinity of Gardena near the axis of the syncline.

In general, where it occurs northwest of the Gardena area just referred to, the “200-foot sand” is coarser on the limbs of the syncline than along the axis.

In the southeastern part of the west basin, about southeast of a line from Gardena to Torrance, the “200-foot sand” usually is logged as fine sand and is tapped by very few wells. Thus, in the area in and near Dominguez Gap it has little importance as an aquifer.

In the area between Torrance and the northeast flank of the Palos Verdes Hills, the “200-foot sand” is largely in physical and hydraulic continuity with the thick series of coarse-grained sediments of the underlying San Pedro formation (shown in the cross sections, pl. 3 *B*, *C*). It is difficult or impossible to separate the two units in this area.

Within the part of the Torrance-Inglewood subarea where it is a productive aquifer—that is, between Torrance and Inglewood and from the coast to the crest of the Newport-Inglewood uplift—the “200-foot sand” underlies about 70 square miles.

The “200-foot sand” is tapped by at least 200 highly productive wells in the vicinity of Gardena. Although little information is available on drawdown, estimated yields for wells tapping this



water-bearing zone range from about 100 to as much as 1,300 gpm. Estimated yields for 22 wells as reported by Mendenhall (1905b, p. 75-80) gave an average yield of 575 gpm. Well 3/14-26E2 is reported to yield 50 gpm with a 3-foot drawdown—a specific capacity of 17 gpm per foot of drawdown.

The thickness of the unnamed upper Pleistocene deposits ranges widely from place to place. Table 4 shows the approximate thickness and depth of both the unnamed upper Pleistocene deposits as a whole and the "200-foot sand" for their occurrence along the synclinal axis from Inglewood southeast to Gardena (pl. 3B), and along the west coast from El Segundo to Hermosa Beach (pl. 3C).

TABLE 4.—Range in thickness and depth (in feet) to the base of the unnamed upper Pleistocene deposits in the northern and central parts of the Torrance-Inglewood subarea

| Deposits                                             | Along coast<br>(El Segundo<br>to Hermosa<br>Beach) | Along axis<br>of syncline<br>(Inglewood to<br>Gardena) |
|------------------------------------------------------|----------------------------------------------------|--------------------------------------------------------|
| Thickness of unnamed upper Pleistocene deposits..... | 60-150                                             | 180-280                                                |
| Depth to base below land surface.....                | 140-250                                            | 240-310                                                |
| Altitude of base below sea level.....                | 20-80                                              | 160-260                                                |
| Thickness of "200-foot sand".....                    | 20-60                                              | 65-135                                                 |

About 5 miles southeast along the synclinal axis from Gardena, at the intersection of Carson and Alameda Streets, the Pleistocene reaches its greatest thickness within the west basin. At this point the base of the unnamed upper Pleistocene deposits is about 350 feet below the land surface, or 325 feet below sea level (pl. 6).

Along the crest of the Newport-Inglewood uplift the unnamed deposits are thickest at Dominguez Hill and in the saddle between Dominguez Hill and the Rosecrans Hills (pl. 3A). Here the "200-foot sand" is represented by about 50 to 100 feet of sand and gravel whose base ranges from 100 to 200 feet below the land surface. Farther northwestward along the crest of the Rosecrans Hills, the base of the unnamed deposits is nearer the surface, owing to uplift, and the aggregate thickness averages 50 feet or less. The deposits may have been eroded to a certain extent during or after the uplift of late Pleistocene time, but it is thought that they may never have reached a greater thickness. Beyond the northwest end of the Rosecrans Hills they feather out against the Baldwin Hills uplift.

On the basis of data now available from wells and outcrops, the unnamed upper Pleistocene deposits within the west basin are inferred to be partly marine origin and partly of continental origin. Wissler reported that samples of deposits taken from wells on Domin-

guez Hill were of nonmarine, presumably fluvial origin. In a very few wells southwest of the Newport-Inglewood uplift, fossils have been reported from these deposits (see logs for wells 4/13-15A11 and 4/14-13F1, table 28), but these have been found in the "200-foot sand" or its stratigraphic equivalent.

The upper half of the unnamed deposits in the Torrance-Inglewood subarea is fine grained and is not known to contain any fossils. Accordingly, most of this upper division is inferred to be a flood-plain deposit.

Because the "200-foot sand" is of coarse texture, is widespread in extent, and is relatively uniform in character and thickness over areas as great as several square miles; and also because it contains fossils at a few places, it is inferred to have been deposited in a shallow marine or littoral environment. As already pointed out, the "200-foot sand" is thickest and best developed in the vicinity of Gardena; here it may represent a deltaic deposit laid down beyond a shoreline that fringed the southwest flank of the Newport-Inglewood uplift.

#### STRATIGRAPHIC RELATIONS

The stratigraphic relations between the unnamed upper Pleistocene deposits and the underlying San Pedro formation are not definitely known. The contact between these two stratigraphic units is nowhere exposed, and well logs are inadequate to supply critical evidence. However, it appears likely that the unnamed deposits are conformable on the San Pedro formation along the synclinal axis; probably they are locally unconformable along the crest of the Newport-Inglewood uplift. Throughout the extent of the 200-foot sand within the Torrance-Inglewood subarea, the base of this sand is presumed to represent the base of the unnamed upper Pleistocene deposits and the top of the San Pedro formation (pls. 3A, B, C, and 5).

The twelve higher terraces of the Palos Verdes Hills are, at least in part, correlatives of the unnamed upper Pleistocene deposits; this fact indicates that locally, if not regionally, deformation was occurring in the interval during which they were being deposited. Possibly this deformation is reflected in the coarse deposits assigned to the lower part of the unnamed deposits.

#### SAN PEDRO FORMATION

##### DEFINITION

For the ground-water investigation of the adjacent Long Beach-Santa Ana area, the San Pedro formation of early Pleistocene age has been defined (Poland, Piper, and others, 1956, p. 60-62) as that stratigraphic unit underlying the unnamed upper Pleistocene deposits (just described) and overlying the Pico formation of late Pliocene

age. It has been discriminated for that area partly from outcrops but mostly by data from water and oil wells—drillers' logs, electric logs, samples taken during drilling, and faunal studies. By similar methods of correlation, the San Pedro formation has been traced over most of the Torrance-Santa Monica area.

The San Pedro formation is considered to be essentially correlative with (but much thicker and more heterogeneous) the type San Pedro sand, Timms Point silt, and Lomita marl as defined by Woodring and others (1946, p. 43-53). However, it doubtless includes some younger strata; and it may include some which are older than any exposed in the type section just cited. Owing to the heterogeneous materials of this unit, the nonlithologic designation "San Pedro formation" is preferred to "San Pedro sand." The Timms Point silt and the Lomita marl are treated as the two basal members of the formation.

As here defined, the San Pedro formation embraces all strata of early Pleistocene age. In most of the Torrance-Santa Monica area, the San Pedro formation occurs between the unnamed upper Pleistocene deposits above and the Pico formation below. However, in the northern and southern parts of the area shown on plate 2, major unconformities occur at both its top and its base so that locally it underlies the Palos Verdes sand of late Pleistocene age and rests on rocks as old as upper Miocene (p. 56).

For the stratigraphic units with which the San Pedro formation of this report is correlative—the San Pedro sand, the Timms Point silt, and the Lomita marl of Woodring and others—the type exposures occur low on the east flank of the Palos Verdes Hills in and near San Pedro—the extreme southern part of the area shown on plate 2.

In the type area, the San Pedro sand is made up largely of stratified and crossbedded sand, but it includes some beds of fine gravel, silty sand, and silt. Its component particles are derived chiefly from some distant area of granitic rocks; however, according to Woodring, some of the gravel beds contain pebbles of limestone, siliceous shale, and schist, which are assumed to have been derived locally from the Palos Verdes Hills. In that same area, two local stratigraphic units of early Pleistocene age underlie the San Pedro sand of Woodring; in downward succession they are the Timms Point silt and the Lomita marl. The Timms Point silt of the type area is composed of brownish to yellowish sandy silt and silty sand. Its type outcrop at Timms Point has been described by Clark (1931, p. 25-42). The underlying Lomita marl consists chiefly of marl and calcareous sand.

The type locality of the Lomita marl is near Lomita quarry, about a mile southwest of Lomita. Foraminifera from the Lomita marl at the quarry have been described by Galloway and Wissler (1927).

Woodring ranks the Timms Point silt and Lomita marl as formations. However, because they cannot now be traced as distinct units to the north of the Palos Verdes Hills, for purposes of this report they are treated as the basal members of the San Pedro formation, as was done in the report on the geology of the Long Beach-Santa Ana area.

Woodring reports that in the San Pedro area the greatest exposed thickness of the San Pedro sand is about 175 feet, of the Timms Point silt about 80 feet, and of the Lomita marl about 70 feet. He estimates that these three lower Pleistocene units where concealed in that same area, have a maximum thickness of about 600 feet.

#### REPRESENTATIVE EXPOSED SECTIONS

For the northeast flank of the Palos Verdes Hills, Woodring (1946, p. 45-53) has described a number of exposed sections of the San Pedro sand, the Timms Point silt, and the Lomita marl. Details will not be repeated here. However, one of the best exposures of the San Pedro sand is about 2,000 feet west of Narbonne Avenue, in 4/14-35E, at the Sidebotham sand pits nos. 1 and 2. Here the Lomita marl is absent, and the San Pedro sand rests directly on the Malaga mudstone member of the Monterey formation. The no. 1 pit exposes about 100 feet of sand and interbedded layers and lenses of gravel dipping gently northward. The sand is gray or reddish-brown and includes thin crossbedded units. Its aspect, as shown in a photograph in the recent report by Woodring and others (1946, pl. 19, p. 58), is typical of that observed in exposures in the Baldwin Hills, described beyond, and at Huntington Beach Mesa in the Long Beach-Santa Ana area. In other pits or ravines farther west, along the north border of the hills, the character of the sand and gravel of the type San Pedro sand does not differ significantly from the exposures just described; the Palos Verdes sand was found unconformably overlying the San Pedro in several of these ravines. As exposed in the several gravel pits along the north edge of the Palos Verdes Hills, the San Pedro sand appears to be highly permeable.

In addition to the exposures of the San Pedro formation just described, the only other known outcrops of this formation within the Torrance-Santa Monica area are in the Baldwin Hills and along the Ballona escarpment.

About 40 feet of the San Pedro formation is exposed in the northern part of the Baldwin Hills, in a sand pit on the east side of Moynier Lane about 250 feet southeast of well 2/14-8C1. The lower part of this section comprises about 25 feet of light-buff massive well-sorted fine granitic sand; this is overlain by about 15 feet of white medium sand, which contains pebbles as large as 1 inch in diameter near the top.

An exposure in another sand pit, about 1,000 feet south of the locality just described but on the west side of Moynier Lane, consists of about 45 feet of silty sand, sand, and gravel. In upward sequence, it comprises: 10 feet of interbedded sand and sandy gravel, with pebbles largely of metamorphic rocks and some granite; 4 feet of coarse loose sand; a 4-inch bed of dark reddish-brown fine sandstone; 6 feet of well-sorted fine loose sand; and at the top of the exposure, 25 feet of massive fine silty sand containing a few layers of scattered pebbles as much as 3 inches in diameter.

In the middle of 2/14-18, at the west border of the Baldwin Hills, about 50 feet of the San Pedro formation is exposed in a gravel pit about 400 feet east of the junction of Overland Avenue and Playa Street. The lower 20 feet of this section consists of light-gray coarse-grained loose crossbedded sand; this is overlain by about 30 feet of light-brown medium- to coarse-grained loose sand with scattered streaks of gravel from 1 to 2 inches thick, which contains pebbles of quartz, metamorphic rocks, and granite as much as 1 inch in diameter. The upper 6 feet of this sand is weathered to a reddish-brown sandy soil.

#### FAUNAL DATA FROM OUTCROPS AND WELLS

In regard to the San Pedro formation as it occurs within the Torrance-Santa Monica area, faunal studies have been confined to subsurface samples except for the type outcrops in the Palos Verdes Hills, which have been studied by Woodring and his associates (1946, p. 43-53) and by several other investigators. (For references, see Poland, Piper, and others, 1956, p. 64.)

For this report, as in the report on geology of the Long Beach-Santa Ana area the nomenclature and faunal divisions employed by S. G. Wissler (1943) are usually accepted in order to develop the most uniform correlation of Pleistocene and Pliocene strata.

During the drilling of well 4/13-15A11, near the intersection of Alameda and Carson Streets in Dominguez Gap, samples were collected at 10-foot intervals by Paul Karnes of the Roscoe Moss Co. These samples were examined by S. G. Wissler for faunal correlation. From foraminiferal determinations, Wissler (oral communication, January 7, 1947) reported the first good San Pedro fauna at 690 feet below the land surface and suggested from fragmentary data that the top of the San Pedro formation might be as high as 450 feet. On the basis of lithologic correlation, the top is here taken at 415 feet below the land surface, at the base of a bed of sand and gravel 65 feet thick, which is inferred to represent a coarse southeasterly correlative of the "200-foot sand" in the unnamed upper Pleistocene deposits already described. The strata from 415 feet to the total depth of 1,040 feet

are assigned to the San Pedro formation. From logs of nearby wells, it is believed that this part of the San Pedro formation is about 800 feet thick and that its base is about 1,200 feet below land surface (pl. 2).

Core samples from well 3/14-10G2, which was drilled for the city of Inglewood (well 30) about 1 mile northeast of Hawthorne, were made available by the Kalco Drilling Co. and were examined by Wissler and Natland for faunal correlation. Both men were in agreement (Wissler, S. G., oral communication, January 7, 1947; Natland, M. L., oral communication, January 9, 1947) that a fauna essentially equivalent to that associated with the Timms Point silt and the Lomita marl is present from 564 to 825 feet below the land surface at this well. Wissler inferred that the base of the San Pedro formation is just below the deepest core obtained, which was at 825 feet below the surface. The base of the Silverado water-bearing zone is 710 feet below the land surface at this well.

Samples from well 3/14-29D3 (well 11 of the city of Manhattan Beach) were also examined for faunal correlation by Wissler (oral communication). He reported that the base of the San Pedro formation, placed by the Geological Survey at 431 feet below land surface, essentially agrees with the position indicated by the megafossils found in the samples.

Samples were collected at about 10-foot intervals during the drilling of a test well for the Richfield Oil Corp. about 2 miles east of El Segundo (well 3/14-8N3, Richfield Leuzinger No. 1). Wissler examined these samples and placed the base of the San Pedro formation at about 790 feet below the land surface. A megafossil zone, which occurred from 180 to 240 feet below the surface is inferred to mark the top of the San Pedro formation. The base of the Silverado water-bearing zone here is about 440 feet below the land surface; and fine-grained silt and clay containing Timms Point-Lomita fauna extend some 350 feet below the base of the Silverado water-bearing zone.

From paleontologic examination of ditch samples from oil wells drilled near the crest of Dominguez Hill, Wissler concluded that the San Pedro formation was reached from 175 to about 670 feet below land surface (1943, p. 212).

In regard to the Rosecrans Hills, Wissler based his determination on paleontologic evidence from an oil well in 3/13-19A (about half a mile west of the crest of the Newport-Inglewood uplift) Wissler (written communication) assigned the deposits from 210 to 570 feet below land surface to the San Pedro formation.

Additional data on depth and thickness of the San Pedro formation obtained from other oil fields are shown graphically on plate 7 as

diagrammatic columnar sections. In certain fields, particularly in the Potrero oil field, the base of the San Pedro formation is estimated by Wissler to be somewhat lower than is shown by the contacts on the geologic sections (pl. 3A, C) and by the contours on the geologic map (pl. 2). In such areas, it is probable that the fine-grained deposits underlying the water-bearing zones represent a basal interval containing the Timms Point-Lomita fauna.

Water-bearing deposits that contain a similar faunal assemblage as much as several hundred feet thick have been deposited extensively to the north and northeast of Signal Hill in the Long Beach area (Poland, Piper, and others, 1956, p. 67).

From the evidence just presented, it is apparent that, at least locally within and near the west basin, deposits of impermeable silt and clay underlie the Silverado water-bearing zone and contain a Timms Point-Lomita fauna; therefore these deposits are a basal part of the San Pedro formation. Thus, the contours on the base of the water-bearing zones of Pleistocene age shown on plate 2 do not everywhere represent the base of the San Pedro formation. However, the contours on plate 2 are believed not only to depict with fair accuracy the base of these water-bearing beds of the San Pedro formation but also, for most of the area, to represent generalized structure contours on the base of the deposits of Pleistocene age.

#### THICKNESS

The thickness of the San Pedro formation varies greatly within the Torrance-Santa Monica area, largely because deformation and erosion have been active since its deposition. The formation has been upturned and beveled by erosion at the outcrop along the north border of the Palos Verdes Hills (pls. 2, and 3B, C). Along the south flank of the Santa Monica Mountains the San Pedro formation doubtless is also upturned and beveled, but there it is capped by upper Pleistocene and Recent terrace and alluvial deposits and is not exposed at the land surface. In the Baldwin Hills, the San Pedro formation is domed upward and broken by faults and is at or near the surface over more than half the total area of the hills, as shown on plates 2 and 3A. The San Pedro is folded into an anticline and faulted over the crest of the Newport-Inglewood uplift southeast of the Baldwin Hills; it does not crop out on the Rosecrans and Dominguez Hills.

The general range in thickness of the San Pedro formation is shown on the several geologic sections. In the west basin it attains a thickness of about 800 feet in the synclinal trough beneath Dominguez Gap, near the intersection of Carson and Alameda Streets. It may have a greater thickness, possibly 900 feet, in the sharp syncline beneath the inner harbor in Wilmington (pl. 2). To the northwest

its greatest thickness is in the synclinal trough extending past Inglewood to Ballona Gap, but it decreases gradually in thickness to about 500 feet at Gardena, to 400 feet west of Inglewood, and to 300 feet beneath Ballona Gap. Thicknesses along the crest of the uplift and along the coast are shown by geologic sections on plate 3C. Except within the Baldwin Hills and the Palos Verdes Hills, where the formation has been partly or completely removed by erosion, it is thinnest along the coast near El Segundo (about 100 feet) and along the Newport-Inglewood uplift crest beneath Ballona Gap (about 50 feet, pl. 3D).

Inland from the Newport-Inglewood uplift, its greatest thickness is in the synclinal trough that trends northwest through Huntington Park and terminates beneath Ballona Gap at the north flank of the Baldwin Hills (pl. 2). Beneath Huntington Park the thickness of the San Pedro formation may be as much as 1,500 feet (pl. 4); farther southeast toward Orange County and beyond the extent shown on plate 2, it is about 3,000 feet thick.

Contours drawn on plate 2 show the altitude of the base of the water-bearing zones of Pleistocene age. It has already been pointed out (p. 44) that for the treatment in this report the base of the San Pedro formation is assumed to be at the base of these water-bearing zones, although, from faunal evidence, locally the base of the San Pedro is somewhat lower. As shown by these contours, the approximate base of the San Pedro formation is lowest at Wilmington and at the intersection of Carson and Alameda Street about a mile south of Dominguez Hill; at these places it is about 1,200 feet below sea level. Along the crest of the Newport-Inglewood zone it rises to about 400 feet below sea level at Dominguez Hill, less than 100 feet below sea level in the middle of the Rosecrans Hills, and to 400 feet above sea level in the Baldwin Hills, where in places it intersects the land surface.

#### PHYSICAL CHARACTER AND WATER-BEARING PROPERTIES

*General features.*—Study of data from well logs shows that the San Pedro formation underlies most of the Torrance-Santa Monica area south of the Santa Monica plain, except where older rocks are exposed on the Baldwin Hills and the Palos Verdes Hills. For much of the area north of Ballona Gap (beneath the Santa Monica plain) the deposits of Pleistocene age cannot be divided on the basis of data now available, and the northward limits of the San Pedro formation are not known.

As shown on the geologic sections (pls. 3-5), along the northern border of the Palos Verdes Hills from Redondo Beach to Wilmington, the San Pedro formation is composed almost entirely of sand and gravel. To the north and east, the formation contains extensive beds



of silt and clay. Within the Torrance-Inglewood subarea, these impermeable beds commonly are in the upper part of the formation and hence overlie and confine the Silverado water-bearing zone. Northward beneath Ballona Gap, west of the Baldwin Hills, the San Pedro formation is mostly sand with some gravel. Locally, however, it includes thick interbeds of silt.

Northeast of the Newport-Inglewood uplift, in the main coastal basin, the San Pedro formation cannot be subdivided into an upper part of clay and silt and a lower part of sand and gravel. Instead, it becomes heterogeneous in character and the water-bearing beds interfinger irregularly with layers of silt and clay.

Along the central part of the synclinal trough, from Inglewood to and beyond Gardena, the silt and clay beds within the San Pedro formation separate the coarser water-bearing deposits into two distinct aquifers (pl. 3B). The upper of these two aquifers wedges out along both limbs of this syncline. The lower can be traced beneath nearly all the area from El Segundo and Inglewood southeast to the Palos Verdes Hills and Long Beach. It is the major aquifer within the west basin and has been named the Silverado water-bearing zone. These two water-bearing zones are described in considerable detail in the following paragraphs.

*"Four-hundred-foot gravel."*—From study of well logs on a peg model, correlated with the position of the water level, a distinct water-bearing zone in the upper part of the San Pedro formation has been located in the synclinal trough southwest of the Newport-Inglewood uplift. This water-bearing zone is well defined from Inglewood southeast to about 3 miles beyond Gardena—a total distance of about 10 miles. Where best developed, it is characteristically composed of gravel or of sand and gravel, and its base is about 400 feet below land surface along the axis of the syncline (pl. 3B); accordingly, it has been designated the "400-foot gravel" for purposes of this report. Along the synclinal axis the thickness ranges from 20 to 120 feet. To the west and east of the axis it feathers out against the two limbs of the syncline. The limits of the "400-foot gravel" cannot be precisely defined because well logs suggest that locally it merges with the Silverado water-bearing zone, especially southwest of Gardena. However, the approximate extent of the "400-foot gravel" has been shown on figure 2. As shown there, it is about 10.5 miles long, about 2 miles wide, and underlies approximately 20 square miles. Beyond its southeastern limit as shown on the illustration, and extending along the synclinal trough to Dominguez Gap, a deposit of fine sand of irregular thickness is shown in logs of many wells; this deposit of fine sand possibly represents the stratigraphic extension of the "400-

foot gravel". Doubtless the fine sand has general hydraulic continuity with the "400-foot gravel."

Along the axis of the syncline (pl. 3B) the "400-foot gravel" commonly is overlain and underlain by impermeable layers of silt and clay from 50 to 180 feet thick and thus is physically and hydraulically separated from the "200-foot sand" above and the Silverado water-bearing zone beneath.

The "400-foot gravel" does not crop out at the land surface and so is known only from its occurrence as shown by well logs. Representative logs are given in table 28. (See logs for wells 2/14-23L1 3/13-30A2, 3/14-4N2, 10G1, and 22A1.) It is tapped by several wells of the city of Inglewood, and by three wells of the Southern California Water Co. (3/14-10C1, 22A1, and 23L1); also by many privately owned irrigation wells.

The yield is known for only two wells that tap the "400-foot gravel." Well 3/14-10C1 has a reported yield of 500 gpm; tests show that well 3/14-23L1 yielded 600 gpm with a drawdown of 51 feet, giving a specific capacity of about 12 gpm per foot of drawdown. This water-bearing zone is less than 50 feet thick as tapped in these two wells; thus the permeability is inferred to be relatively high, and about the same as that of the underlying Silverado water-bearing zone.

The "400-foot gravel" is entirely a confined aquifer and contains water under artesian pressure. As shown by the hydrograph for well 3/14-23L1 (fig. 5), the water level in this gravel near Gardena in 1945 was only a few feet above the pressure level in the Silverado water-bearing zone beneath. Because under native conditions recharge to the "400-foot gravel" presumably was chiefly through its marginal hydraulic contact with the Silverado water-bearing zone, the current head differential would indicate that the "400-foot gravel" now is receiving little recharge.

*Silverado water-bearing zone.*—In an earlier report (Poland, Piper, and others, 1956, p. 69) the name "Silverado water-bearing zone" was assigned to the most extensive of the Pleistocene aquifers of the Long Beach-Santa Ana area. The informal term Silverado water-bearing zone is not to be confused with the formal term Silverado formation (of Woodring and Popenoe, 1945) of Paleocene age of the Santa Ana Mountains, Orange County. The Silverado water-bearing zone was named for its typical occurrence in well 4/13-23G2 in Silverado Park within the city of Long Beach; the log is given in table 28. At this well the Silverado water-bearing zone is represented by 478 feet of sand and gravel from 596 to 1,074 feet below land surface. From data on other wells in the vicinity, the base of the Silverado water-bearing zone at this well is considered to be about 1,100 feet below land surface, and the full thickness to be about 500 feet (pl. 2 and fig. 2). The

upper 300 feet of the zone is highly permeable clean sand and gravel; the lower 200 feet is chiefly coarse sand.

The Silverado water-bearing zone underlies most of the Torrance-Inglewood subarea and extends inland about 2 miles beyond the crest of the Newport-Inglewood uplift. Its known extent and thickness within the area treated in this report are shown on figure 2. As delimited on that illustration, it underlies about 140 square miles and also extends southeastward about 6 miles beyond the east margin shown on figure 2, almost to the Orange County line as shown in an earlier report (Poland, Piper, and others, 1956, pl. 8). Its over-all extent within Los Angeles County is about 165 square miles.

Figure 2 shows the known range in the thickness of the Silverado water-bearing zone by means of isopachs (lines showing equal thickness) based on well-log information. Thus it is to be noted that the Silverado zone attains its greatest thickness (about 700 feet) near Bixby Slough in the Wilmington district. In general it is thinnest along the northern border of its known extent—about 100 feet at the coast near El Segundo, and less than 50 feet in Centinela Park in Inglewood. Except for the inordinate thickening in the synclinal fore-deep immediately north of the Palos Verdes Hills, the average thickness of the Silverado water-bearing zone is about 200 feet.

The range in physical character of the Silverado zone from gravel to sand and gravel, and in places to sand, is well shown on geologic sections, plates 3A-C and 5. Many of the logs included in table 28 are of wells that penetrate the Silverado water-bearing zone. Among those in which the material ascribed to the Silverado is most characteristic are wells 3/13-28A1, 3/14-4N2, 3/14-22A1, 3/15-13R2, and 4/14-13F1. These logs indicate that the water-bearing parts of the zone are predominantly coarse sand and gravel; the maximum pebble diameter averages  $\frac{1}{2}$  to 1 inch, and reach a maximum of 2 inches (3/15-13R2, 4/14-13F1) and 4 inches (3/14-4N2). In the Torrance-Inglewood subarea interbedded layers of impervious silt, sandy clay, or clay within the Silverado zone locally reach a few tens of feet in aggregate thickness.

In most of the area between Long Beach and Redondo Beach the Silverado water-bearing zone is essentially a uniform mass of sand and gravel, with almost no interbedded clay or silt layers. It is chiefly gravel in the vicinity of Wilmington but becomes finer westward to Redondo Beach and Hermosa Beach, where it is largely sand. The Silverado zone is the thickest and the most productive water-bearing unit in this southern reach.

In the vicinity of Gardena and Hawthorne, where it is about 200 feet thick, the Silverado zone usually consists of about half sand and half sand and gravel, and contains few layers of silt. At Manhattan

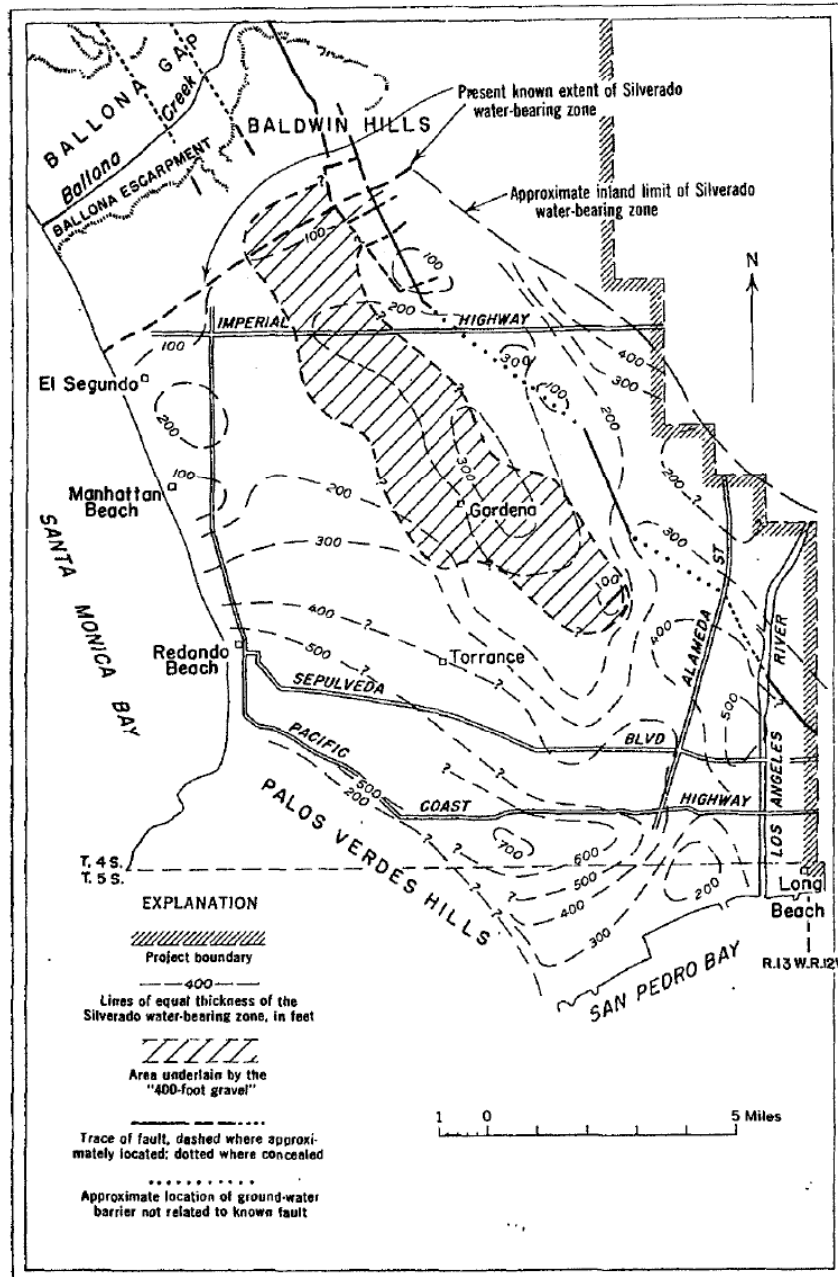

FIGURE 2.—Map showing extent and thickness of the Silverado water-bearing zone within the Torrance-Santa Monica area.

Beach, as tapped by the municipal wells west of Sepulveda Boulevard in 3/15-25A, the Silverado zone is irregular, but in most wells it includes one layer of sand and gravel about 50 feet thick, with a thinner layer below (pl. 4). To the north, near El Segundo, in sec. 13, T. 3 S., R. 15 W., logs of wells show that the Silverado zone is about 230 feet thick and contains from 2 to 4 layers of gravel separated by bodies of silt or clay (pl. 3C).

The Silverado water-bearing zone is tapped by many of the wells of the city of Inglewood. It is thickest (230 feet) in well 3/14-10G1 (Inglewood well 28), northeast of Hawthorne. Near the center of Inglewood, at well 2/14-28M1 (Inglewood well 26), it is only 45 feet thick. Within the Inglewood area, however, the zone is almost entirely gravel or sand and gravel and is moderately permeable.

Few water or oil wells have been drilled in the northern part of the Torrance-Inglewood subarea (an area about 5 miles long and 2 miles wide, parallel to and just south of the Ballona escarpment). Logs are not available for this area to show if the Silverado water-bearing zone is stratigraphically and hydraulically continuous with the thick water-bearing zone of the San Pedro formation beneath Ballona Gap. However, because of the general similarity in physical character and common position in the lower part of the San Pedro formation, it is inferred that the water-bearing zone in the San Pedro beneath the gap is correlative to the Silverado zone to the south and that the two zones have hydraulic continuity.<sup>2</sup>

Beneath the coastal 4-mile segment of Ballona Gap, most of the San Pedro formation is composed of permeable sand and gravel (pl. 3D). Farther inland, beyond the Inglewood fault at the Sentney plant of the Southern California Water Co., in the NW¼ sec. 5, T. 2 S., R. 14 W., the San Pedro formation contains three distinct aquifers separated by impervious layers of silt or clay (2/14-5D6, table 28); the lower two aquifers probably are stratigraphic equivalents of the Silverado water-bearing zone.

Inland, beyond the crest of the Newport-Inglewood uplift, the Silverado water-bearing zone and the whole San Pedro formation interfinger into more silty and clayey types of beds. This change from coarser to finer sediments involves a transition from shallow-water marine and littoral deposits to nonmarine deposits.

<sup>2</sup> Since the present report was released to the open file (1948), the California Division of Water Resources has completed its investigation (draft of report of referee, 1952). Additional information obtained in the State's investigation confirms the stratigraphic and hydraulic continuity of the Silverado water-bearing zone in the Torrance-Inglewood subarea with the thick water-bearing zone of the San Pedro formation beneath Ballona Gap. Hence, plate 6 of the State's report shows that the Silverado water-bearing zone extends north to and underlies the Ballona Gap.

The Geological Survey has made a laboratory examination of samples collected during the drilling of two deep wells within the west basin. Detailed descriptions of the material in these wells is presented in table 28 (3/14-29D3 and 4/13-15A11). The lithologic character of the material in these wells, which has been ascribed to the Silverado water-bearing zone, may be summarized as follows: Relatively clean fine to coarse gray arkosic sand, which is moderately well sorted, with particles subangular to subrounded; and clean gravel consisting of subrounded to rounded fragments of granitic and metamorphic rocks as much as 2 inches in diameter. A variation from fine sand to coarse gravel is usually represented in beds within the zone; the gravel is predominant in the basal part.

As discussed previously (Poland, Piper, and others, 1956, p. 78-84), the San Pedro formation is thought to have been formed by streams, which carried rock debris from an inland uplifted source across a coastal plain and deposited the material as coastal deltas. These deltas were continuously reworked by strong longshore currents. Throughout much of early San Pedro time, the shoreline maintained a position about 3 miles northeast and nearly parallel to the Newport-Inglewood uplift; that shoreline extended southeastward from the east edge of the Baldwin Hills through what is now the city of Compton. The Silverado zone was deposited seaward from the shoreline, chiefly as beach and shallow marine deposits.

The Silverado water-bearing zone is by far the most important aquifer in the Torrance-Inglewood subarea. In 1945 the Silverado zone was the source of water for essentially all the withdrawals by industries; essentially all the withdrawals by the municipal well fields of Hawthorne, El Segundo, Manhattan Beach, and Torrance, and about one-third of the withdrawal by the well fields of the city of Inglewood within the west basin; nearly all the withdrawals by the larger water companies, and at least half the withdrawals by private irrigators and by the smaller water companies. Of the total withdrawal from the Torrance-Inglewood subarea in 1945—some 78,000 acre-feet—about 68,000 acre-feet, or about 87 percent, was taken from the Silverado water-bearing zone (p. 110).

Wells tapping the Silverado water-bearing zone in the Torrance-Inglewood subarea range in tested capacity from a few hundred to as much as 4,000 gpm. For the area immediately west of Long Beach in T. 4 S., R. 13 W., the yield characteristics have been given in another report (Poland, 1959). Table 5 shows the yield characteristics of 39 wells that draw water solely from the Silverado zone within the Torrance-Santa Monica area (fig. 2).

52 GEOLOGY, HYDROLOGY, TORRANCE-SANTA MONICA AREA

TABLE 5.—Yield characteristics of 39 wells tapping the Silverado water-bearing zone in the Torrance-Santa Monica area

| Well            | Depth (feet) | Water-yielding zone or zones |                  | Yield characteristics      |                  |                                |                           |
|-----------------|--------------|------------------------------|------------------|----------------------------|------------------|--------------------------------|---------------------------|
|                 |              | Depth range (feet)           | Thickness (feet) | Yield (gallons per minute) | Draw-down (feet) | Specific capacity <sup>1</sup> | Yield factor <sup>2</sup> |
| 2/14-34C1.....  | 450          | 264-362                      | 98               | 700                        | 70               | 10                             | 10                        |
| 3/14-1B2.....   | 390          | 184-282                      | 98               | 508                        | 16               | 32                             | 33                        |
| 1F1.....        | 350          | 165-339                      | 174              | 1,240                      | 12               | 103                            | 59                        |
| 1G1.....        | 598          | 220-290                      | 61               | 512                        | 21               | 24                             | 40                        |
| 9N4.....        | 670          | 300-402                      | 76               | 1,050                      | 50               | 21                             | 28                        |
| 10G1.....       | 798          | 492-711                      | 118              | 600                        | 17               | 35                             | 30                        |
| 13B1.....       | 800          | 273-543                      | 161              | 675                        | 30               | 23                             | 14                        |
| 13J3.....       | 620          | 359-602                      | 129              | 700                        | 20               | 35                             | 27                        |
| 19C1.....       | 400          | 221-268                      | 28               | 800                        | 50               | 16                             | 57                        |
| 21B2.....       | 527          | 310-468                      | 158              | 433                        | 3                | 144                            | 91                        |
| 29D3.....       | 520          | 190-431                      | 112              | 600                        | 25               | 24                             | 21                        |
| 29G1.....       | 570          | 173-350                      | 177              | 1,800                      | 28               | 64                             | 36                        |
| 30A2.....       | 525          | 187-297                      | 110              | 1,125                      | 55               | 20                             | 19                        |
| 30D1.....       | 350          | 225-255                      | 30               | 905                        | 54               | 17                             | 56                        |
| 3/15-12B1.....  | 400          | 185-240                      | 55               | 680                        | 54               | 12.6                           | 23                        |
| 13H2.....       | 456          | 352-425                      | 73               | 1,000                      | 20               | 50                             | 69                        |
| 13J1.....       | 400          | 181-373                      | 123              | 850                        | 32               | 27                             | 22                        |
| 13R2.....       | 480          | 339-460                      | 121              | 860                        | 13               | 66                             | 55                        |
| 13R4.....       | 440          | 366-407                      | 41               | 560                        | 16               | 35                             | 85                        |
| 13R5.....       | 504          | 284-456                      | 56               | 1,000                      | 34               | 29                             | 52                        |
| 13R6.....       | 495          | 275-410                      | 103              | 900                        | 50               | 18                             | 17.5                      |
| 25A3.....       | 350          | 222-295                      | 54               | 615                        | 36               | 17                             | 32                        |
| 4/13-15A11..... | 1,054        | 765-990                      | 235              | 2,000                      | 14.5             | 138                            | 59                        |
| 21H5.....       | 731          | 440-731                      | 291              | 1,450                      | 5                | 290                            | 100                       |
| 27M3.....       | 946          | 266-800                      | 534              | 3,000                      | 12               | 250                            | 47                        |
| 30G2.....       | 695          | 216-492                      | 276              | 2,900                      | 28               | 104                            | 38                        |
| 31E4.....       | 680          | 230-655                      | 425              | 4,000                      | 10               | 400                            | 94                        |
| 4/13-31F1.....  | 900          | 675-822                      | 147              | 1,650                      | 28               | 59                             | 40                        |
| 33D1.....       | 888          | 669-800                      | 131              | 2,500                      | 19               | 131                            | 100                       |
| 4/14-1H2.....   | 596          | 475-538                      | 45               | 810                        | 29               | 28                             | 62                        |
| 1H3.....        | 596          | 418-547                      | 70               | 1,375                      | 33               | 42                             | 60                        |
| 8C1.....        | 518          | 166-510                      | 344              | 1,500                      | 13               | 115                            | 33                        |
| 17N1.....       | 400          | 206-394                      | 188              | 640                        | 7                | 91                             | 48                        |
| 22D1.....       | 404          | 206-404                      | 198              | 375                        | 6                | 63                             | 32                        |
| 4/14-22D2.....  | 390          | 212-390                      | 178              | 215                        | 2                | 108                            | 61                        |
| 23N2.....       | 640          | 486-640                      | 154              | 945                        | 13               | 73                             | 47                        |
| 35J1.....       | 500          | 180-500                      | 320              | 1,300                      | 19               | 68                             | 21                        |
| 36H1.....       | 610          | 152-610                      | 458              | 1,340                      | 15               | 89                             | 19                        |
| 5/13-6D2.....   | 900          | 735-842                      | 107              | 1,470                      | 32               | 46                             | 43                        |
| Average.....    | 580          | -----                        | 160              | 1,169                      | 25               | 75                             | 46                        |

<sup>1</sup> Gallons per minute per foot of drawdown.

<sup>2</sup> Yield factor =  $\frac{\text{Specific capacity} \times 100}{\text{Thickness of aquifer, in feet}}$

NOTE.—In tables 5 and 6, specific capacity (relation of drawdown to discharge) is used as the convenient scale for the water-yielding capacity of a well and for the relative transmissibility of the water-bearing zone at the place. In addition, specific capacity has been divided by thickness of water-bearing material yielding water to the well, and the quotient so obtained has been multiplied by 100 for convenience in expression. The result has been termed the "yield factor." The yield factor here is introduced as an approximate relative measure for the permeability of the water-bearing material tapped by a well. Specific capacity and yield factor both involve drawdown, which (as measured in a well) is due to two increments of head loss: (1) that incident to movement of water toward the well through material of a certain average permeability and (2) that incident to entrance of water into the well casing. Thus, both specific capacity and yield factor depend not only on the characteristics of the water-bearing material tapped but also on the number, size, and condition of perforations in the casing and their distribution within the water-bearing zones tapped.

The 39 wells listed in table 5 show averages as follows: Yield 1,169 gpm, drawdown 25 feet, specific capacity 75 gpm per foot of drawdown, and yield factor 46 (specific capacity  $\times 100$  divided by the thickness of aquifer, in feet). Within the Torrance-Inglewood subarea, table 5 shows no significant difference in yield factor for wells in the several townships, which indicates that although the thickness of the Silverado zone is more than twice as great between Long Beach and Redondo Beach as in the area north of Gardena, the permeability is essentially the same throughout its known extent in the west basin.

The permeability is a measure of the ability of a material to transmit water. It may be expressed as a field coefficient of permeability, expressed as the number of gallons of water per day that percolates through each mile of the water-bearing bed (measured at right angles to the direction of flow) for each foot of thickness of the bed and for each foot per mile of hydraulic gradient (Wenzel, 1942, p. 7).

Within the west basin the permeability of the Silverado water-bearing zone was determined from a pumping test near Bixby Slough, in sec. 31, T. 4 S., R. 13 W. This pumping test was made chiefly to determine whether a barrier to ground-water movement existed between the wells of the Union Oil Co. (wells 4/13-31P1 and 5/13-6D2) and nearby wells at (1) the Lomita plant, city of Los Angeles, in 4/13-31E, and (2) the Palos Verdes Water Co., in 4/14-36H (pl. 2). The conclusions with respect to a hydraulic barrier are described elsewhere (p. 139 and fig. 8). The data also afforded an opportunity to determine transmissibility<sup>3</sup> and permeability.

On September 28, 1946, the pumps at the Lomita plant were idle and had been shut down for several days previously. The wells of the Union Oil Co. had been pumped continuously for several months before the test, and the wells of the Palos Verdes Water Co. had been operated intermittently. During the day, wells 4/13-31P1 and 5/13-6D2 (Union Oil Co.) and well 4/14-36H1 (Palos Verdes Water Co., well 1) were pumped intermittently on an alternating schedule (fig. 8) and water-level measurements were made at about 10-minute intervals from 10:00 a. m. to 9:00 p. m. at wells 4/13-31E4, 4/13-31P1, and 4/14-36H1. The fluctuation of water level in these wells is shown on figure 8. Between 12:10 and 4:10 p. m., the water level in well 31E4 recovered along a uniform curve, as a result of the shut-down of the pumps in the Union Oil Co. wells from noon to 4:00 p. m. From 4:10 to 7:10 p. m., the water level in well 31E4 declined concurrently with pumping of the Union Oil Co. wells. The time-drawdown graph for well 31E4 was utilized to compute transmissibility in ac-

<sup>3</sup> Transmissibility is expressed as the field coefficient of permeability multiplied by the thickness of the saturated part of the aquifer in feet.



cordance with a procedure described by Cooper and Jacob (1946). The transmissibility was determined by use of the equation

$$T = \frac{263.9Q}{\Delta s}$$

where  $T$  is transmissibility in gpd per foot,  $Q$  is discharge of the pumped well in gallons per minute, and  $\Delta s$  is the change in drawdown in an observation well over one logarithmic cycle (drawdown plotted against time on semilogarithmic paper, with time on the logarithmic scale). During the test the average joint discharge from the Union Oil Co. wells was about 2,150 gpm and the change in drawdown in well 31E4 was about 0.97 foot during one logarithmic cycle. Thus, the indicated transmissibility is about 600,000 gpd per foot. The thickness of the water-bearing deposits tapped at well 31E4 is 425 feet, indicating a permeability of about 1,400 gpd per square foot.

The transmissibility and permeability of the Silverado water-bearing zone in the reach between Wilmington and Torrance were determined from the fluctuation of pressure level in well 4/14-13F1, near Torrance, during the pumping of wells 4/13-30G1 and 4/13-30K1 (city of Los Angeles, Lomita plant wells 6 and 7), 12,000 feet to the southeast, in Wilmington. The hydrograph for well 4/14-13F1 and the draft at the Lomita plant are shown elsewhere on figure 6. A time-drawdown graph was constructed as described for the pumping test of the Union Oil Co. wells near Bixby Slough. The average joint rate of discharge from wells 4/13-30G1 and 4/13-30K1 from April 19 to May 2, 1944, was 4,340 gpm. The change in drawdown in well 4/14-13F1 was about 1.41 feet during one logarithmic cycle. Thus, utilizing the equation for obtaining transmissibility given in the preceding paragraph, the indicated transmissibility is about 813,000 gpd per foot. The average thickness of the Silverado water-bearing zone between the pumped wells and observation well 4/14-13F1 is about 400 feet, indicating a permeability of about 2,000 gpd per square foot. This test is considered to furnish a more accurate and more representative value for the permeability of the Silverado water-bearing zone between Torrance and Long Beach than the test at Bixby Slough, because the latter pumping test was made in an area where physical texture, thickness, and permeability of the Silverado water-bearing zone are believed to change between the pumped wells and the observation well—whereas between Wilmington and Torrance the physical character and thickness are reasonably uniform. Also, the Silverado water-bearing zone wedges out on the flank of the Palos Verdes Hills about 4,000 feet southwest of the Union Oil Co. wells and about 10,000 feet southwest of wells 4/13-30G1 and 4/13-30K1. Thus, for the pumping test at the Union Oil Co. wells, the cone of

pressure relief must have extended rapidly to the non-water-bearing rocks, resulting in distortion during subsequent growth of the cone. On the other hand, the cone surrounding wells 4/13-30G1 and 4/13-30K1 would reach well 4/14-13F1 about as soon as it impinged upon the non-water-bearing rocks and the distortion would have little if any effect on drawdown in well 4/14-13F1, which is about 3.4 miles distant from the south boundary of the basin.

At the Centinela Park well field of the city of Inglewood the permeability of the water-bearing beds of the San Pedro formation—beds essentially correlative to the Silverado water-bearing zone—has been determined from the fluctuation in observation well 2/14-27D1 (city of Inglewood, well 7) during the pumping of well 2/14-22N2 (city of Inglewood, well 9). The hydrograph for well 2/14-27D1 is shown on figure 7. Utilizing the time-drawdown graph and applying the formula of Cooper and Jacob (p. 54), the transmissibility has been estimated at about 55,000 gpd per foot. The saturated thickness of water-bearing beds was about 50 feet at the time of the test. Thus, the permeability here is about 1,100 gpd per square foot.

For the extent of the water-bearing zones of the San Pedro formation in and near the Ballona Gap—zones correlative with the Silverado water-bearing zone in age and physical character—table 6 gives the yield characteristics of eight wells.

TABLE 6.—Yield characteristics of eight wells tapping the San Pedro formation in the vicinity of Ballona Gap

| Well           | Depth (feet) | Water-yielding zone or zones |                  | Yield characteristics      |                  |                                |                           |
|----------------|--------------|------------------------------|------------------|----------------------------|------------------|--------------------------------|---------------------------|
|                |              | Depth range (feet)           | Thickness (feet) | Yield (gallons per minute) | Draw-down (feet) | Specific capacity <sup>1</sup> | Yield factor <sup>2</sup> |
| 2/14-4N1.....  | 300          | 118-219                      | 66               | 1,010                      | 31               | 33                             | 50                        |
| 7P2.....       | 265          | 112-187                      | 18               | 550                        | 75               | 7.3                            | 41                        |
| 23H2.....      | 827          | 449-796                      | 136              | 3,050                      | 40               | 76                             | 56                        |
| 2/15-11D2..... | 480          | 198-340                      | 114              | 345                        | 24               | 14                             | 12                        |
| 11E3.....      | 405          | 196-376                      | 169              | 1,125                      | 17               | 66                             | 39                        |
| 11E5.....      | 452          | 217-430                      | 181              | 1,155                      | 36               | 32                             | 18                        |
| 11F4.....      | 380          | 168-346                      | 176              | 1,805                      | 32               | 56                             | 32                        |
| 34K1.....      | 208          | 91-133                       | 42               | 355                        | 21               | 17                             | 40                        |
| Average.....   | 415          |                              | 113              | 1,174                      | 35               | 38                             | 36                        |

<sup>1</sup> Gallons per minute per foot of drawdown.

<sup>2</sup> Yield factor =  $\frac{\text{Specific capacity} \times 100}{\text{Thickness of aquifer, in feet}}$

As shown by this table, the average yield of the 8 wells is 1,174 gpm, almost identical to the average yield for the 39 wells tapping the Silverado water-bearing zone to the south. The yield factor for the 8 wells is 36, as compared to a factor of 46 for the 39 wells of table 5. Thus, it is concluded that the permeability of the water-bearing

beds in the San Pedro in the vicinity of Ballona Gap is somewhat lower than that of the Silverado water-bearing zone, probably about three-quarters as great.

#### STRATIGRAPHIC RELATIONS

The rocks overlying and underlying the San Pedro formation are separated from it by unconformities. The unnamed upper Pleistocene deposits apparently were laid down after some folding of the San Pedro formation had occurred along the Newport-Inglewood uplift, and are inferred to overlie the San Pedro unconformably at places along this uplift. Subsequent to their deposition, parts of these upper Pleistocene deposits and parts of the San Pedro formation were eroded during the development of the upper Pleistocene marine (Palos Verdes) surface. Therefore, the Palos Verdes sand, which was deposited on this surface, doubtless is locally unconformable on the unnamed upper Pleistocene deposits, and in some places, as at Signal Hill and at the intersection of Lincoln Boulevard and the Ballona escarpment, it rests directly on the San Pedro formation.

The Tertiary rocks underlying the San Pedro formation are reported by Woodring (1946, p. 109, and pl. 1) to be unconformable with it wherever the relations have been clearly exposed in the Palos Verdes Hills area. Here the Pico formation of late Pliocene age is missing and the San Pedro formation rests in part on lower Pliocene and upper Miocene rocks.

Throughout the remainder of the Torrance-Santa Monica area, with the exception of the Baldwin Hills, the contact of the San Pedro formation with the underlying Tertiary rocks is concealed. Unconformities are more likely to be present along the Newport-Inglewood belt than beneath the Torrance or Downey plains. Structural activity along this zone, if it took place during or after the deposition of a group of rocks, could rarely avoid causing a break in the sedimentation and would be registered as an unconformity within that group or between it and the overlying younger deposits. Wissler (oral communication) believes that activity along the Newport-Inglewood belt began in early upper Miocene time, and he infers (Wissler, 1943, p. 231) that there is an unconformity between the Pico and San Pedro formations in the Dominguez and Rosecrans fields.

The Tertiary rocks (upper division of the Pico formation) in the Baldwin Hills area are exposed at several places and are cut by the main Inglewood fault into an eastern and a western block. Driver (1943, p. 308) states that "the Pleistocene is conformably deposited over the Pliocene in the western block, but is unconformable in the eastern block."

During excavation for a storm drain, east of Culver City and one-third of a mile north of the Baldwin Hills, in 1936, Natland <sup>4</sup> found that the Tertiary strata were separated by an unconformity from the overlying sands of the San Pedro formation.

#### TERTIARY SYSTEM

##### PLIOCENE SERIES

##### GENERAL FEATURES

In most of the area shown on plate 2, strata of Tertiary age underlie the Quaternary rocks. They crop out at the surface only in the flanks of the Santa Monica Mountains and in the Baldwin and Palos Verdes Hills. These rocks consist chiefly of marine silt and sand, containing only local lenses of gravel.

The Pliocene series is subdivided on the basis of microfauna into two formations in the Los Angeles basin—the Pico above and the Repetto below. The Pico formation, although absent from the geologic column in the Palos Verdes Hills, is present throughout the remainder of the Torrance-Santa Monica area and so is underlain by the Repetto formation.

The Pico formation has been divided by stratigraphers into upper, middle, and lower divisions on the basis of distinct microfaunal assemblages (Wissler, 1943, p. 212-213). For the purposes of the present investigation, a discussion of the upper division of the Pico formation and its water-bearing characteristics is pertinent, because the relatively permeable sand members in the lower part of the upper division generally contain essentially fresh ground water. In much of the area shown on plate 2, the base of the main fresh ground-water body is approximately at the base of the lowest of these upper Pico sand members (p. 86 and pl. 8).

Because permeable sand beds in the middle and lower divisions of the Pico formation within the project area contain only connate saline water, those divisions will be treated only briefly here; they are discussed in detail in many reports on the petroleum geology of the Los Angeles basin.

##### PICO FORMATION, UPPER DIVISION

##### PHYSICAL CHARACTER AND THICKNESS

The upper division of the Pico formation consists of semiconsolidated sand and micaceous silt and clay of marine origin. Locally, beds of fine gravel occur in the upper part of the division, presumably also of marine origin.

The upper division of the Pico formation underlies all the area shown on plate 2 except the south flanks of the Santa Monica Mountains

<sup>4</sup> Natland, M. L., unpublished data from Shell Oil Co., 1936.

and the northern border of the Palos Verdes Hills. The only known exposures of this upper division are in the northern sector of the Baldwin Hills, where they occur as buff siltstone and buff fine silty sand or sandstone with limonitic clayey partings and limonitic concretions. The exposures in these hills are not differentiated on plate 2 from the rocks of lower Pliocene and Miocene age.

Hoots (1931, p. 116) reported that the upper part of the Pliocene section which is exposed about 2 miles outside the west boundary of the area, in Potrero Canyon, "is equivalent to a part of the Pico formation exposed at its type locality in Pico Canyon."

Along the Newport-Inglewood structural zone and in the west basin, the upper few hundred feet of the upper division is composed chiefly of silt and clay. Beneath the Baldwin Hills, according to Wisler (1943, p. 213), most of the entire upper division of the Pico is silt. To the north the character of the upper division of the Pico is not known. However, in almost all of the area south and southeast of the Baldwin Hills, the lower 600 to 1,000 feet of the upper division includes several beds of fine- to medium-grained sand and sandstone and, locally, beds of fine gravel. The geologic sections, plates 3A and 4 to 6, show the general disposition of these permeable zones as revealed in a few cored wells and as inferred from electric logs.

These coarser beds commonly range from 25 to as much as 100 feet in thickness, and are separated by beds of massive micaceous siltstone. Thus, about 2.5 miles southeast of Dominguez Hill, well 4/13-17D1 reached the upper division of the Pico from 683 to 1,701 feet below land surface (Poland, Piper, and others, 1956, p. 87, 143). In this well the sand occurs in 10 layers totaling 282 feet—about 28 percent of the thickness. The casing of this well was never perforated, so neither the yield of the deposits nor the chemical character of the water is known.

Well 4/13-12A2 (city of Long Beach, North Long Beach well 6), about a mile northeast of the Newport-Inglewood uplift and a mile east of the Los Angeles River, was drilled to a depth of 1,955 feet, cutting through about half the upper division from 726 feet to the bottom. (See log, table 28.) Within this depth interval, the drillers reported nine water-bearing beds, totaling about 240 feet, or about 20 percent of the top half of the upper division of the Pico, which consist of fine sand and fine gravel with some clay.

Well 3/14-17J1, an oil-test hole about a mile southwest of Hawthorne cut through the entire thickness of the upper division, beginning at about 500 feet below land surface. The electric log indicated fresh-water-bearing sand between 1,110 and 1,320 feet. Three other beds of sand, each about 50 feet thick, were reached in this well between 1,750 and 2,100 feet, but these lower sand members, near the

base of the upper division, are inferred to contain brackish water (pl. 8). A pumping test, made to determine the productivity and the quality of the water in the sand member between 1,110 and 1,320 feet, is described on page 61.

Inland from the Newport-Inglewood uplift, in the area northeast of Dominguez Hill, the deposits of the upper division of the Pico are not tapped by water wells, so far as known. However, electric logs and samples from a few oil-test holes on the Downey plain indicate that this section of the upper division of the Pico formation is almost entirely of marine origin and of the same general character as its west basin equivalent.

Within the area shown on plate 2, the upper division of the Pico formation ranges in thickness from 1,800 feet beneath Dominguez Gap at the southeast end of the Dominguez anticline to feather edges against the uplifts of the Santa Monica Mountains and the Palos Verdes Hills. As shown on plate 7, the thickness is about 1,000 feet at Playa del Rey; 1,300 feet at the El Segundo oil field, and 1,100 feet at the Torrance oil field; about 900 feet at the Inglewood oil field, in the Baldwin Hills; about 1,200 feet southeastward along the Newport-Inglewood uplift at the Rosecrans oil field; 775 feet at the crest of Dominguez Hill, and 1,440 feet at the northwest end of the Long Beach oil field. Inland, beyond the area shown on plate 2, the upper division probably increases in thickness to much more than 2,000 feet beneath the central Downey plain.

#### STRATIGRAPHIC RELATIONS

At least locally, the upper division of the Pico was deposited on a surface of unconformity. However, throughout much of the Torrance-Santa Monica area, data are insufficient to determine with assurance the stratigraphic relation of the upper division to the underlying older rocks. Furthermore, the relations of this upper division to the overlying Pleistocene rocks are uncertain in many places.

In the Torrance-Wilmington area relations are well established and, according to Wissler (1943, p. 213), the upper division overlaps the middle division of the Pico; in the Long Beach harbor district of the Wilmington oil field it rests directly on the Repetto formation of early Pliocene age. At the north border of the Palos Verdes Hills, where the San Pedro rests locally on the Repetto and on rocks of Miocene age, the upper division of the Pico is absent.

Along the Newport-Inglewood uplift, an unconformity between the upper division of the Pico and the San Pedro formation in the Rosecrans and Dominguez oil fields was inferred by Wissler (1943, p. 212), because of the apparent absence in these fields of the Timms Point fauna, which occurs at the Seal Beach oil field.

Inland beyond the Newport-Inglewood uplift, beneath the Downey plain, it is likely that no unconformity exists and that sedimentation took place almost continuously from late Pliocene into Pleistocene (San Pedro) time.

#### WATER-BEARING CHARACTER

Within most of the area shown on plate 2, except beneath and north of the Baldwin Hills, the upper division of the Pico formation contains layers of semiconsolidated sand which should yield substantial quantities of essentially fresh water to wells of adequate construction. The productivity of these sand layers in this area can be inferred from pumping tests at two wells and from a laboratory test of permeability of the sand from a third well, as described beyond.

Information derived largely from electric logs of oil wells and prospect holes suggests that, in much of the area covered in this report, the water in these sand members of the upper division of the Pico is either fresh or suitable for certain industrial uses.

The position of the top of the transition zone between fresh and saline ground water has been ascertained from the electric logs of representative oil wells and prospect holes. Contours drawn on the top of the transition zone are presented on plate 8, these contours mark the approximate position of the base of the principal fresh-water body, as defined elsewhere in this report. Although correlation between oil fields in this region is precarious because of the usually pronounced lateral variation in lithology (Wissler, 1943, p. 234), the group of sand members generally prevalent in the lower part of the upper division of the Pico can be traced from one field to another; this general lithologic correlation is supported by studies of the foraminiferal assemblages. A comparison of the position of the top of the transition and of the base of the upper division, as determined by micropaleontologists, shows that they almost coincide in this region. Notable exceptions are at the Potrero oil field, where the top of the transition zone is as much as 400 feet above the base of the upper division of the Pico; and at the west end of the Torrance oil field, in the Redondo Beach area, where the transition to saline water is 300 feet above the base of the upper division. In these two areas, and also locally in the Wilmington oil field, one or more of the lowest sand members ascribed to the upper division contain connate saline ground water.

With respect to specific information on water-bearing characteristics of the upper division of the Pico formation, some data are available as a result of two recent attempts to construct wells that penetrated the fresh-water sands of this formation.

One of these wells, 3/14-17J1, about a mile southwest of Hawthorne, was initially a "wildcat" oil well drilled to a depth of 4,200 feet by the

Loren L. Hillman Co., Inc., and designated "West Hawthorne No. 1." This well was utilized by the Standard Oil Co. of California in 1946 to test the aquifers in the upper division of the Pico formation with respect to quality of the water and productivity of the sands. The electric log indicated a permeable zone containing essentially fresh water from 1,120 to 1,320 feet below the land surface. To test this zone, the hole was plugged off below a depth of 1,294 feet. A double liner with an outer-pipe diameter of 8 $\frac{1}{2}$  inches and an inner-pipe diameter of 7 $\frac{1}{2}$  inches, prepacked with gravel between the two pipes, was landed at 1,294 feet and extended into the 11 $\frac{1}{2}$ -inch casing set at 849 feet. The prepacked liner was perforated from 1,089 to 1,294 feet, opposite the permeable zone.

An initial bailing test was made on this well late in May 1946, at an estimated rate of 25 gpm for about 24 hours. After 20,000 to 30,000 gallons was bailed, the chloride concentration was about 120 ppm. The apparent static level then was about 119 feet below land surface, or about 38 feet below sea level, and the drawdown was about 38 feet after the water became relatively clear.

Subsequently, a pump was installed and a yield test was made by the Standard Oil Co. on August 1-4, 1946. The static level before the test was 111 feet below the land surface, or 30 feet below sea level. The pump bowls were set 400 feet below the land surface. The water yielded during the test contained a large amount of fine sand as well as particles of colloidal size; it was still turbid after standing several days. The maximum yield was at a rate of about 25 gpm; but this yield is not indicative of the productivity of the zone because the liner presumably filled with sand early in the test. At the end of the test, sand filled the casing to 728 feet below the land surface, about 360 feet above the top of the perforations.

In the latter part of August 1946 the sand was removed from the casing and a bailing test was made. The maximum rate of bailing was reported to be about 50 gpm with a drawdown of 50 feet. At the end of the bailing test, when the drawdown was 38 feet, the water level recovered 35 feet in 20 minutes. Large quantities of sand were removed from the well during this bailing test. The company decided that further tests were not warranted and the well was abandoned.

Chemical analyses of water collected during the pumping test and in the final bailing test were made by the Standard Oil Co. (see table 30). The quality of the water is discussed on page 183.

Although the tests made on well 3/14-17J1 were unsuccessful from the standpoint of yield, it is believed that a well constructed to exclude sand, such as a gravel-packed well of 24- to 30-inch diameter with an envelope of fine gravel or coarse sand, probably would yield several times as much water as was obtained during this test. The prepacked



gravel liner utilized for the test was only 8½ inches in outside diameter and the gravel screen was less than half an inch thick.

The other type of the two wells tapping the sand members of the upper division of the Pico on which yield-test data are available is a water well drilled by the city of Long Beach in the spring of 1946—well 4/13-12A2 (city of Long Beach, North Long Beach well 6)—about 6 miles north of the business district of Long Beach. Drilled to a total depth of 1,955 feet, the well penetrated about 1,200 feet into the upper division of the Pico—or about 50 percent of the total depth range of the sand zones containing fresh water in the upper division at that locality (see log, table 28). A 26-inch casing was set to a depth of about 360 feet and a 16-inch casing to 1,955 feet; the latter casing was perforated from 1,805 to 1,955 feet. The well flowed 106 gpm. The water was dark brown and had a temperature of 104° to 106°F. Sufficient methane was present to burn continuously when ignited at the open casing.

On October 7, 1947, a yield test was made on this well and the yield was estimated at 400 gpm, with a drawdown of about 60 feet from a static level about 15 feet above land surface, or 53 feet above sea level. Thus the specific capacity was about 7 gpm per foot of drawdown.

Although the content of dissolved solids was moderate (see chemical analysis, table 30), the water was not considered suitable for public supply because of its high temperature and dark color. The cost of treatment to make the water suitable for use was considered too costly, and the well was abandoned.

During the drilling of the well, samples were collected by the city at each change in character of the material, and at 10-foot spacings below 1,470 feet. In the laboratory of the field office of the Geological Survey at Long Beach, permeability tests were made on samples from four of the coarser zones within the depth range of the casing perforations. Coefficients of permeability for these four zones, as determined in the laboratory, are as follows: at 1,890 feet below land surface, fine to coarse sand, some fine gravel, 454 gpd per square foot; 1,900 feet—fine to coarse sand, some silt, little fine gravel, 212 gpd per square foot; 1,910 feet—silty sand and gravel, pebbles as large as ½ inch in diameter, 20 gpd per square foot; 1,940 feet—silty fine to medium sand, 16 gpd per square foot.

Additional information on the permeability of the upper division of the Pico was obtained from well 3/14-8N3 (Richfield Leuzinger well 1), which was drilled by the Richfield Oil Corp. about 2 miles east of El Segundo to test the oil and gas possibilities of the Pico formation. Through the courtesy of this company, a sample of sand from a permeable zone in the upper division of the Pico formation between 1,220 and 1,240 feet below land surface was made available to the Geological

Survey. A laboratory test indicated a permeability of 242 gpd per square foot. A mechanical analysis of this sand gave the composition tabulated below, indicating that the size ranges from fine gravel to very fine sand, but that 34 percent is medium sand.

| <i>Mechanical composition<br/>(millimeters)</i> | <i>Percent<br/>of dry<br/>weight</i> |
|-------------------------------------------------|--------------------------------------|
| Fine gravel (more than 1.00).....               | 2. 3                                 |
| Coarse sand (1.00 to 0.5).....                  | 24. 6                                |
| Medium sand (0.5 to 0.25).....                  | 34. 0                                |
| Fine sand (0.25 to 0.125).....                  | 31. 1                                |
| Very fine sand (0.125 to 0.05).....             | 8. 0                                 |

Information summarized on preceding pages suggests that the production of water from the upper division of the Pico formation within or near the west basin would require wells of substantial depths, probably as much as 1,500 feet on the average. Also, the sand members of the upper division are fine grained and wells of special construction—with a thick gravel pack or a carefully selected screen—would be required to withdraw water effectively. Such wells would be much more expensive than the water wells now utilized in the area. At some places, especially along and near the crest of the Newport-Inglewood uplift, yields of as much as 1,000 gpm might be obtained locally with a drawdown of not more than 100 feet. Within most of the west basin, however, it is doubtful that yields would exceed a few hundred gallons per minute with such a drawdown.

Although yields from the upper division might be substantial along the Newport-Inglewood uplift, it is concluded that the color of the water probably would be amber to dark brown and thus the water probably would require treatment for domestic use, even though the chemical quality should prove to be satisfactory. This color is presumed to be caused by organic matter in colloidal suspension. It is believed that coloring by organic matter would not be excessive within most of the west basin, but the water might be turbid, similar to the water of well 3/14-17J1, and might require treatment.

The temperature of waters withdrawn from the upper division of the Pico ranged from 90° to 110°F. Therefore, these waters probably would have to be cooled for domestic use although such temperatures might not be objectionable for some industrial uses.

For wells tapping the upper division along the Newport-Inglewood uplift but inland from the west basin boundary, the static level would be above the current water levels in the Pleistocene water-bearing zones, and at places where the altitude of land surface is low, as at well 4/13-12A2, the wells would flow.

Wells tapping the upper division of the Pico formation within the west basin probably would register initial pressure levels ranging from

sea level to possibly as much as 40 feet below sea level. Thus, to yield substantial quantities of water even from wells of special construction, initial pumping levels probably would be about 100 feet or more below sea level. Because replenishment to the water-bearing beds of the upper division in the west basin is inferred to be small or negligible, pressure levels presumably would decline fairly rapidly if large quantities of water were withdrawn from the sands of the upper division.

The water-bearing beds in the upper division of the Pico within the west basin contain a large quantity of water. If the average aggregate thickness of the sand layers containing essentially fresh water is approximately 200 feet, and the area is about 120 square miles, an assumed effective porosity of 25 percent would indicate storage of about 3 to 4 million acre-feet. If replenishment is negligible, as seems likely, only a small part of this quantity could be withdrawn without lowering pumping levels far below sea level. Because exploratory and well-construction costs would be high, the water yielded from the upper division of the Pico would cost substantially more per acre-foot than the ground water now yielded by wells in the west basin. Extensive development of the water in the water-bearing beds of the upper division to abate the current overdraft in the west basin does not offer a permanent solution to the water-supply problems of the basin.

#### PICO FORMATION, MIDDLE AND LOWER DIVISIONS

The middle and lower divisions of the Pico formation do not crop out within the area shown on plate 2. As determined from cored samples from oil-test holes, they comprise interbedded sandstone, claystone, siltstone, and shale. According to Wissler (1943, p. 214-215), the percentage of sand in the middle Pico averages about 40 percent for the oil fields within the Torrance-Santa Monica area; on the other hand, the lower division of the Pico contains about 60 percent of sand.

Among the oil fields within the area, the combined thickness of the middle and lower divisions ranges from about 400 feet at the Torrance oil field to more than 1,700 feet at the Potrero field (pl. 7), although somewhat greater thicknesses presumably occur in the basin areas between the structurally high oil fields.

In the Torrance-Wilmington area the lower division is overlapped by the middle division, the latter resting with angular discordance on the Repetto formation of early Pliocene age (Wissler, 1943, p. 215). Along the north border of the Palos Verdes Hills, the entire Pico and in many places the Repetto are overlapped by the San Pedro formation of lower Pleistocene age (Woodring and others, 1941, p. 40-41).

Elsewhere within almost all the Torrance-Santa Monica area and south of the Santa Monica Mountains, both the middle and lower divisions of the Pico formation are present and are essentially conformable with each other and with the overlying upper division and the underlying Repetto.

Within the area shown on plate 2, the water in the sand zones of the middle and lower divisions of the Pico formation is believed to be saline. However, inland beneath the Downey plain, electric logs from scattered "wildcat" oil wells indicate that essentially fresh water is contained in the sandier zones of the middle division of the Pico.

#### OLDER ROCKS OF TERTIARY AGE

Underlying the Pico formation in the Torrance-Santa Monica area are sedimentary rocks of lower Pliocene (Repetto formation) and of Miocene age. Lithologic descriptions of these rocks and their known range in thickness are given in table 3. Their distribution and thickness in the several oil fields of the area are summarized in plate 7. They include most of the oil-producing zones of the Los Angeles basin area and thus have been treated in detail in many reports concerned with the production of the oil resources of this area; however, they do not contain fresh water. The reader who desires information about these older formations is referred to the selected references given in an earlier report (Poland, Piper, and others, 1956, p. 93).

#### PRE-TERTIARY ROCKS

The pre-Tertiary rocks that crop out within the Torrance-Santa Monica area are generally considered to be of Mesozoic age. All are non-water-bearing and are briefly described here merely to complete the stratigraphic sequence.

As shown on plate 2, the pre-Tertiary rocks crop out only locally along the south border of the Santa Monica Mountains. According to Hoots (1931, p. 88-93), they are represented by the Santa Monica slate of Triassic(?) age, a Jurassic(?) igneous intrusion of granite and granodiorite, and the upper Cretaceous Chico formation consisting of conglomerate, sandstone, and shale. The Chico formation, where it occurs in the area, was not differentiated by Hoots from the Martinez formation of Paleocene age because of a dense covering of brush and unexposed structural complications.

In the Palos Verdes Hills, the pre-Tertiary rocks constitute a metamorphic complex which forms a central core, which crops out only in a limited area on the northern slope of the hills about a mile south of the southern boundary of the area mapped on plate 2. These rocks consist of quartz-sericite, quartz-talc, and quartz-glaucophane schist and altered basic igneous rocks which have been ascribed by

Woodford (1924, p. 62) to a correlative of the Jurassic(?) Franciscan group of the Coast Ranges. However, because there are no unaltered sedimentary rocks among these schist beds, Woodford considered the alternative that they might be older than the Franciscan—a possibility which also has been emphasized by Taliaferro (1943, p. 122-125).

## GEOLOGIC STRUCTURE

### REGIONAL FEATURES

The thick sequence of sedimentary rocks underlying the coastal plain has been deposited in a broad synclinal depression often referred to as the Los Angeles basin. In the structurally deepest part of the basin, beneath the central part of the Downey plain, the rocks of Tertiary and Quaternary age probably are more than 20,000 feet thick. Along the north and northeast margins of the basin, and locally to the southwest at the Palos Verdes Hills, these rocks have been extensively elevated, folded, faulted, and eroded, to expose a complex of igneous and metamorphic rocks (pl. 1).

The general synclinal structure of the basin is interrupted by the composite faulted anticlinal belt that extends southeastward from the Beverly Hills to Newport Beach—the Newport-Inglewood uplift. In effect, this uplift divides the coastal plain into two synclinal troughs. To the northeast, a broad syncline underlies the Downey plain and extends southeastward from the north flank of the Baldwin Hills through Huntington Park and continues into Orange County. To the southwest, a relatively narrow syncline extends from Santa Monica to Long Beach and forms the structural trough known as the west basin.

The Tertiary and Quaternary rocks dip gently inland and coastward from the crest of the Newport-Inglewood uplift. Along the synclinal axis within the west basin, their thickness ranges from a few thousand to as much as 13,000 feet. Here they overlie a schist basement complex which has been reached by many oil wells (White, 1946; also see Schoellhamer and Woodford, 1951). Southwest beyond the syncline, these rocks are warped over the Torrance-Wilmington anticlinal structure and are flexed sharply upward into the Palos Verdes Hills. Along the north flank of the Palos Verdes Hills, a deep fault is indicated by data from oil-prospect holes, but the Pleistocene rocks at the land surface are not ruptured (Woodring, 1946, p. 110, pls. 1 and 21; Schultz, 1937, fig. 4) except in the local area southeast of Redondo Beach (pl. 2).

Within the Newport-Inglewood uplift and in the two flanking synclines, all rocks older than the alluvial deposits of Recent age are deformed. Also, because the rocks have been deformed recurrently

since Miocene time, the flexure in the Pleistocene rocks is reflected with increasing amplitude in the rocks of Pliocene and late Miocene age. As shown by the contours on the base of the water-bearing zones of Pleistocene age (pl. 2), however, much of the structural deformation has occurred since the time of early San Pedro deposition, chiefly during the so-called mid-Pleistocene revolution, which took place after deposition of the San Pedro formation.

#### NEWPORT-INGLEWOOD UPLIFT

##### GENERAL FEATURES

The Newport-Inglewood uplift is a regional anticlinal fold broken by echelon faults, and extending northwestward from the Newport Mesa to the Beverly Hills, a distance of 40 miles. Throughout its extent within Los Angeles County, it is marked at the surface by the common alinement of Signal, Dominguez, Rosecrans, Baldwin, and the Beverly Hills. The continuity of these five hills is broken by two erosional gaps—Dominguez and Ballona Gaps (pl. 8).

Superimposed on this regional anticlinal structure are successive closed anticlines or domes and intervening structural saddles. The domes and, to a lesser degree, the saddles are broken by discontinuous normal and reverse faults arranged in echelon, many of which do not reach the land surface.

According to Wissler, the Newport-Inglewood uplift has been a zone of structural activity since Miocene time. Stratigraphic evidence has been presented that indicates recurrent movement along the zone during later Tertiary and Quaternary time. Recent major earthquakes—the Inglewood earthquake of 1921 and the Long Beach earthquake of 1933—and a minor earthquake in 1941, which damaged several oil wells in the Dominguez oil field, indicate that the zone is still active.

The folds and faults along the Newport-Inglewood uplift at the inland boundary of the west basin form a substantial if discontinuous barrier to water movement from the main (central) coastal basin to the west basin. For example, the crestal position of the impermeable rocks at the base of the water-bearing zones of Pleistocene age determines the depth of the lip below which water cannot pass into the west basin. The depth of this lip in the reach south of the Baldwin Hills has been shown on plate 3A. Also, the discontinuous faults along the uplift have produced ground-water barriers that partly restrain the coastward movement of ground water. This restraint has been produced to a small degree by displacement of water-bearing zones but it is chiefly due to cementation, which has developed along the fault planes. Thus, both folds and faults are critical features in an appraisal of the problem of replenishment to the west basin.

## FOLDS

Four domal uplifts along the Newport-Inglewood structural zone in the Torrance-Santa Monica area are topographically expressed in order from the southeast by Dominguez, Rosecrans, Baldwin, and the Beverly Hills, respectively. Oil fields have been developed on each of these hills: the Dominguez oil field; the Rosecrans and Potrero fields (near the south and north ends) of the Rosecrans Hills, respectively; the Inglewood field on the Baldwin Hills; and the Beverly Hills field. Consequently, because of the studies incident to the development of each field, much information is available on their subsurface geology.

In general, the land-surface contour of the several domal folds is a moderate replica of the subsurface structure, although the initial land surface on the hills has been modified by erosion.

The structure at Dominguez Hill has been described as follows (Poland, Piper, and others, 1956, p. 96):

The most regular domal structure underlies Dominguez Hill, whose general outer form reflects the deeper structural pattern in a subdued degree. Thus, whereas the crest of Dominguez Hill is only about 150 feet above the surrounding plains, the structural relief at the base of the Pleistocene is about 400 feet. [See pl. 2.] According to Grinsfelder (1943, p. 318), mapping on successive stratigraphic horizons indicates that the effect of the tectonic forces was progressively greater at increasing depth, and that "mapping on horizons as deep as 4,000 feet reveals an elliptical anticline with a northwest-trending axis, steep flanks on the southwest, with dips of from 15° to 20°." Thus the structural development of this anticline has gone on recurrently through much of Tertiary and Quaternary time.

The Rosecrans Hills comprise an irregular low swell about 3 miles wide and 8 miles long extending from Dominguez Hill northwestward to the Baldwin Hills.

Near the south end of the hills, structure contours at a depth of about 4,000 feet reveal three small domes with a northwest alignment which constitute the Rosecrans oil field (Musser, 1925). Musser has inferred that the three domes are separated by minor faults trending northeastward. At shallow depth the inferred faults apparently are absent, and the attitude of the base of the Pleistocene water-bearing zones, about 200 feet below sea level, assumes a somewhat irregular elliptical shape. The inland and coastward dip of the base of these water-bearing zones is about 2° to 3°.

At the north end of the Rosecrans Hills, the steeper western slope has a nearly straight topographic break parallel with the long dimension of the hills which marks the surface trace of the Potrero fault (see p. 72). This fault passes through the center of the structure on which the Potrero oil field is developed (Willis and Ballantyne, 1943, p. 310)—an elongated dome whose long axis trends about N. 65°

W. The top of the producing zones, at the highest part of the dome, is about 3,000 feet below the land surface. At this depth the dips average  $8^{\circ}$ , whereas at the base of the Pleistocene water-bearing zones, about 250 feet below the surface (pl. 3A), the dips are much gentler—from about  $1^{\circ}$  to  $2^{\circ}$ . Impermeable beds underlie these water-bearing zones at a depth of about 50 feet below sea level.

The most pronounced and complex uplift along the Newport-Inglewood structural zone, at the Baldwin Hills, consists of a north-westward-trending dome, whose central crest has been dropped between two fault zones (Driver, 1943, p. 308). Of these two fault zones, the easterly one is known as the Inglewood fault (pl. 2). At the depth of the upper oil zone, about 900 feet below sea level, the crest of the dome underlies the SW $\frac{1}{4}$  sec. 8, T. 2 S., R. 14 W., which is about half a mile west of the topographic summit of the Baldwin Hills. The peripheral outward dips generally are less than  $20^{\circ}$ , except at the northwest edge of the hills, where the dip is  $35^{\circ}$  to the west (Driver, 1943, p. 308). The uplift is greatest at the northern part of the hills, where the upper division of the Pico formation crops out at the surface (pls. 2, 3A). Within most of the Baldwin Hills area, the base of the permeable beds of Pleistocene age is above sea level; these beds are non-water-bearing.

The Beverly Hills constitute the northernmost of the domal structures which mark the Newport-Inglewood uplift. It is a triangular asymmetric dome underlying the northern part of the hills and is elongated in an east-west direction (Hoots, 1931, p. 132-133 and pl. 34); the closure on this structure trapped the oil produced at the small Beverly Hills oil field in the years following 1908. The oil field is now of little importance as a producer. At the oil zone, 2,500 feet below sea level, the dips on the north flank are from  $15^{\circ}$  to  $20^{\circ}$ , and are nearly  $45^{\circ}$  on the south flank. Along the crest of the Beverly Hills, the base of the water-bearing beds of Pleistocene age is less than 200 feet below land surface and from a few feet to as much as 100 feet above sea level.

#### FAULTS

In the area shown on plate 2, the Newport-Inglewood structural zone is broken by four known major faults which, in order from the southeast, are the Cherry-Hill, the Avalon-Compton, the Potrero, and the Inglewood faults. As shown on plate 2, these faults are arranged in echelon, and strike, generally, more northward than the trend of the zone as a whole.

#### CHERRY-HILL FAULT

The Cherry-Hill fault, which has a known extent of about 5 miles from the east side of Dominguez Gap to and beyond the southwest



flank of Signal Hill, has been discussed in some detail in an earlier report (Poland, Piper, and others, 1956, p. 98). Only the northwestern part of this fault is within the area shown on plate 2.

The Cherry-Hill is a reverse fault, dipping northeast. Land-surface displacement ranges from more than 100 to 40 feet along the southwest flank of Signal Hill, diminishing northwestward. Near the east edge of sec. 24, T. 4 S., R. 13 W., at the east boundary shown on plate 2, the throw or vertical displacement is about 150 feet (Stolz, 1943, p. 321) at a depth of more than 4,000 feet in lower Pliocene rocks. Extension of the fault northwestward across Dominguez Gap (pl. 2) is based upon information obtained during drilling or prospecting for oil, and from an apparent hydraulic discontinuity in the Silverado water-bearing zone (pls. 9-12). The fault probably transects all the deposits of Pleistocene age but does not cut the deposits of Recent age.

#### FAULTS IN THE DOMINGUEZ HILL AREA

So far as known, no faults are present in the surface or near-surface deposits in the Dominguez Hill area. Grinsfelder (1943, p. 318) states that the effects of faulting become evident below 4,000 feet, presumably in the Repetto formation of early Pliocene age. From subsurface studies, Bravinder (1942, p. 390) reported two sets of faults: (1) high-angle faults striking obliquely across the long axis of the dome and (2) south-dipping lower angle thrust faults striking nearly parallel to the axis. Horizontal movement is evident in the oblique set, and the throw is greatest in the Miocene rocks.

Although faults are not known in the Pleistocene deposits along the crest of Dominguez Hill, water levels in wells tapping those deposits indicate a substantial hydraulic discontinuity across the axis of the Dominguez anticline, because water levels on the southwest are from 20 to 40 feet lower than those on the northeast (pls. 9-12). The position of this ground water barrier is only roughly defined by the water-level data. The inferred barrier may be caused by near-surface effects of the faulting, which is known to have occurred at depth. These near-surface effects may be shear zones characterized either by many minor faults of small displacement, or by systems of tension and compression joints with little or no offset. In either case, it is believed that cementation along openings caused by these structures may have produced the ground-water barrier suggested by the differences in water levels. For a discussion of the mechanism of the formation of such cemented zones, the reader is referred to the report on the Long Beach-Santa Ana area (Poland, Piper, and others, 1956, p. 104 and 123).

## AVALON-COMPTON FAULT

The land-surface trace of the Avalon-Compton fault is 2.25 miles long and extends northward from the NW¼ sec. 33, T. 3 S., R. 13 W., on the north flank of Dominguez Hill, to the NW¼ sec. 20, T. 3 S., R. 13 W., 0.1 mile west of the intersection of Rosecrans Avenue and Avalon Boulevard. The fault passes about 500 feet east of the intersection of Avalon Boulevard and Compton Avenue and is designated the Avalon-Compton fault in this report. The fault strikes N. 24° W.; the dip of the fault plane is not known. The trace of this fault has been taken along the topographic discontinuity shown on the Compton topographic sheet and is substantiated by hydrologic data. The average land-surface displacement is about 25 feet, with the dropped block on the southwest side. If this fault is similar to other faults along the Newport-Inglewood uplift, the throw at depth is considerably greater than the vertical displacement at land surface. Well logs are not available, however, to indicate the amount of displacement within the Silverado water-bearing zone, or at greater depth. As shown on plate 12, in November 1945 the water levels northeast of the fault were about at sea level, whereas those across the fault to the southwest were about 30 feet below sea level. This evidence demonstrates the effectiveness of the fault as a ground-water barrier.

## FAULTING IN THE CENTRAL PART OF THE ROSECRANS HILLS

The central 4-mile reach of the Rosecrans Hills is beyond the inferred limits of the Avalon-Compton fault to the southeast and the Potrero fault to the northwest (pl. 2). This central reach has a relatively steep southwest flank, locally scarred by stream erosion. No rupture of the land surface can be noted. The Rosecrans oil field, which is about 3 miles in length, underlies the southern half of this central reach. The producing beds of the Rosecrans oil field are broken by a general northwestward-trending main shear zone and by many transverse faults, but none of these are known to pass upward into beds younger than the Repetto formation.

Although there is no geologic evidence of faults transecting the deposits of Pleistocene age, hydraulic continuity in these deposits is substantially impeded along the approximate position of the ground-water barrier shown on plate 2. So far as known, the most extensive measurements of depth to water in wells in the vicinity of this inferred barrier were made between 1930 and 1932. In 1932, one or more nearby wells became inaccessible. Accordingly, measurements of depth to water in 1931 have furnished the control for the position of the barrier as plotted. A straight line drawn to connect the extremities of the Avalon-Compton and the Potrero faults was

found to separate the higher water levels to the northeast from the lower water levels to the southwest. In November 1945, the water-level displacement across this central barrier was about 30 feet (pl. 12). The cause of this barrier is thought to be similar to the one suggested for the Dominguez Hill area; namely, cementation of shear zones, which are believed to be near-surface reflections of major faulting at depth.

#### POTRERO FAULT AND ASSOCIATED MINOR FAULTS

The trace of the Potrero fault, as shown on plate 2, extends about 4 miles northwestward from the west part of sec. 2, T. 3 S., R. 14 W., to the middle of sec. 16, T. 2 S., R. 14 W., in the eastern part of the Baldwin Hills, and passes through the Centinela Park well field of the city of Inglewood. The fault is marked at the surface by an escarpment about 50 feet high which extends along the west flank of the Rosecrans Hills for about 2.25 miles. At a depth of 3,000 feet, this fault bisects the dome on which the Potrero oil field is developed.

According to Willis and Ballantyne (1943, p. 310), at the Potrero oil field in sec. 34 the Potrero fault is a zone from 100 to 200 feet wide composed of several minor displacements. The general trend of the fault zone is N. 25° W.; the dip is about 82° to the west at depth, but lessens to about 77° at land surface. The throw at a depth of about 3,000 feet is about 270 feet, with the dropped block on the southwest; Willis states that the horizontal component of the displacement is the more important, because the axis of the dome southwest of the fault appears to have been shifted northwestward 1,200 feet relative to the axis northeast of the fault. At the base of the water-bearing zones of Pleistocene age a depth of about 300 feet below land surface, the throw is probably about 100 feet in the north half of 2/14-34 (pl. 2).

However, about a mile to the north in the Centinela Park well field of the city of Inglewood no vertical displacement across the Potrero fault is indicated by well logs. As discussed on page 139, the Potrero fault is a barrier to ground-water movement; therefore, the horizontal component of the displacement in these younger rocks, although presumed to be considerably less than that which is apparent at depth in the oil zones, must at least have been sufficient to produce fracturing and permit cementation. This barrier may be of a mechanical nature, caused by fracturing and pulverizing of the coarser material along the fault plane to form an impervious zone, or it may be a cemented zone similar to that indicated for other localities. Although it is likely that both processes have occurred, cementation is presumed to have caused the principal barrier features.

Between the Potrero fault on the east and the Inglewood fault on the west, in the 3.6-mile reach from Century Boulevard to Slauson Avenue, six transverse faults are shown on plate 2. The four southerly faults have been plotted about in the position indicated by Grant and Sheppard (1939, fig. 8, p. 321); as interpreted by W. S. W. Kew and Graham Moody, reportedly on topographic evidence (Driver, oral communication, January 1947). The two northerly transverse faults, in secs. 21 and 16, T. 2 S., R. 14 W., have been plotted on plate 2 as shown by Graham Moody on an unpublished geologic map of the Baldwin Hills, which was made available through the courtesy of the Standard Oil Co. of California. The three southerly faults are treated here, and the three to the north are discussed later with the Inglewood fault, which they appear to offset.

The most southerly of the inferred transverse faults, near the intersection of Crenshaw and Century Boulevards, is indicated by a land-surface displacement of 10-20 feet, and by a creek channel passing westward along this small topographic offset. No substantiating geologic evidence is known. However, in well 3/14-3A1, a few hundred feet north of this transverse fault and between the Potrero and Inglewood faults, the water level was about 60 feet below sea level in November 1945, which was possibly 20 feet lower than water levels in sec. 3, south of the inferred fault (pl. 12). Thus, a hydrologic discontinuity is indicated and the fault is inferred to be present chiefly on the basis of this hydrologic evidence.

The second inferred transverse fault, near the north edge of sec. 34 (Manchester Avenue) and about 1 mile long, is suggested by a land-surface displacement of about 25 feet, east of the Potrero fault, with the dropped block on the south. However, logs of wells 2/14-27P1 and 34C1, north and south of the fault suggest no displacement at the base of the Silverado water-bearing zone, 220 feet below sea level. Nevertheless, water-level measurements taken in wells 2/14-27P2 and 34C1 in November 1945 were about 60 and 75 feet below sea level, respectively, suggesting a differential in water level across the inferred fault of about 15 feet.

The third inferred fault, which extends westward almost across the center of sec. 27, T. 2 S., R. 14 W., is indicated by a steep northward-facing bluff and a land-surface displacement of about 50 feet, dropped to the north. Logs of water wells indicate a displacement of the water-bearing zones of Pleistocene age, of about 30 to 50 feet in the same direction (pl. 3). Hydrologic data are not available to show whether a hydraulic discontinuity is present across this fault.

## INGLEWOOD FAULT AND ASSOCIATED MINOR FAULTS

The Inglewood fault zone, as shown on plate 2, is about 9 miles long and extends northward from the northern part of the Rosecrans Hills, across the Baldwin Hills, and beneath the Recent deposits in Ballona Gap. Topographic evidence and a hydraulic discontinuity indicate that the zone extends northward beyond the Beverly Hills. Its continuity is interrupted by many transverse faults and as shown on plate 2, it has seven distinct segments. Within the Baldwin Hills area, the fault pattern is plotted as shown on an unpublished map by Moody;<sup>5</sup> to simplify the structural detail, however, many minor faults are not shown.

The southern segment of the Inglewood fault extends northwestward for about 2 miles to the center of sec. 28, T. 2 S., R. 14 W. In section 28 it is identical with the Townsite fault of Willis (1943, p. 311-312). In the northern part of the Rosecrans Hills, from a quarter of a mile south to half a mile north of Century Boulevard, a local steepening of the land-surface profile indicates the inferred surface trace of the Inglewood fault, trending about N. 30° W. However, subsurface and hydraulic evidence for this segment of the Inglewood fault is much more definitive. Logs of water wells in the central part of Inglewood indicate a vertical displacement of at least 100 feet at the base of the Pleistocene water-bearing zones, with the dropped block to the southwest (pl. 2). Also, in sec. 34, T. 2 S., R. 14 W., water levels on the northeast side of the fault were about 20 feet lower in November 1945 than levels southwest of the fault (pl. 12).

At the north end of this southern segment, in the SE¼ sec. 28, T. 2 S., R. 14 W., the trace ends abruptly against a transverse fault about a mile long, which strikes N. 60° E. along a former channel of Centinela Creek. The characteristics of this fault are not well known; logs of water wells indicate a displacement of about 50 feet between wells 2/14-28M1 and 28E1 (city of Inglewood, wells 26 and 23), both of which are west of the Inglewood fault. Here the water-bearing beds are dropped to the south. These wells were drilled about 16 years after Kew (1923, p. 157) wrote that "no stratigraphic evidence is present indicating any faulting in this creek." Thus, the displacement suggested by the logs of these wells, although not conclusively demonstrated, constitutes presumed stratigraphic evidence for the existence of this fault. No hydrologic or chemical data are available for confirmation. The trace of the fault has been drawn along the former channel of upper Centinela Creek, according to information supplied by Kew and Moody (Grant and Sheppard,

<sup>5</sup> Moody, G. B., 1935, Surface geology of the Baldwin Hills, Los Angeles County, Calif., Report for Standard Oil Co. of California.

1939, p. 321, fig. 8); but because it is believed to pass north of well 2/14-28M1, the position of its western part has been shifted about 600 feet to the north.

The Inglewood fault, which at the surface is probably horizontally offset slightly to the west by the transverse fault just described, extends 4 miles northward from that fault across the Baldwin Hills. The fault is again horizontally offset, to a small extent, by two other transverse faults in the southern 1.5 miles of this stretch, and trends about N. 10° W. The northern part, about 3.5 miles long, extends over the Baldwin Hills, and trends about N. 25° W.

The fault pattern in the Baldwin Hills area shows that the Inglewood fault is the more easterly of two faults forming a dropped block or graben along the crest of the hills (pl. 2). It is broken along this graben by several echelon faults which trend about N. 20° E. The Inglewood fault is marked here by a westward-facing escarpment with a land-surface vertical displacement or throw of about 275 feet (Driver, 1943, p. 308 and fig. 128). Locally in the NE¼ sec. 17, T. 2 S., R. 14 W., at the top of the producing zones of the Inglewood oil field, the throw is about 1,000 feet down on the west side, so that that zone is about 2,000 feet below the land surface in the graben and 1,000 feet below the surface east of the fault. Surface and sub-surface data indicate that the horizontal component of the displacement may be five times as great as the vertical component or throw. The fault dips about 80° west at the surface, and becomes less steep with depth.

About parallel to the Inglewood fault and nearly 1,000 feet to the west, another fault forms the west side of the graben. Like the Inglewood fault, it trends about N. 25° W. and is broken by several echelon faults trending N. 10°-20° E.; it dips about 75° to the east. According to Driver, the throw is about 30 feet at the surface and 100 to 200 feet at a depth of about 2,000 feet. The echelon faults along the graben may have been the result of stresses which caused the large horizontal component of movement along the main Inglewood fault.

Bounding the northeast flank of the Baldwin Hills is an unnamed fault about 2 miles long, trending N. 70° W., which extends northwestward and is offset by the Inglewood fault (Driver, 1943, p. 308). The dip of the fault plane is not known, but it is reported to be a normal fault with the downthrown block on the north. Data on a few wells south of the fault at its northwest end show that water levels at this point have been maintained about 90 feet above sea level; the underground drainage from the hills evidently has been trapped in the acute dihedral angle between this fault and the Inglewood fault.

There is substantial evidence north of the Baldwin Hills that the Inglewood fault extends across Ballona Gap with a trend of about N. 26° W. and is concealed beneath alluvial deposits of Recent age. It has already been indicated that (at the crest of the Baldwin Hills anticline) the Inglewood fault marks the eastern boundary of a graben; the strata at the fault are dropped on its west side. Also, information obtained from a study of well logs in Ballona Gap proves that the water-bearing deposits of Pleistocene age have been dropped on the east side of the fault. Therefore, movement along the Inglewood fault must have been pivotal, with a change from downward displacement on the west in the Baldwin Hills, through a pivot of no displacement, to downward displacement on the east in Ballona Gap. The dip of the fault plane in Ballona Gap is not known.

At the intersection of the Inglewood fault with section *D-D'* (pl. 3*D*), the throw is inferred to be about 200 feet. Apparently no movement has occurred along this fault since the beginning of Recent time because the "50-foot gravel" in Ballona Gap shows no evidence of offset.

Evidence that the Inglewood fault affords an effective barrier to ground-water movement through Ballona Gap is shown by the area of flowing wells that existed inland from the fault in 1904 (Mendenhall, 1905b, pl. 6). More recent water-level data also indicate hydraulic discontinuity. For example, in November 1945 water levels east of the fault in secs. 5 and 6, T. 2 S., R. 14 W., near the Sentney plant of the Southern California Water Co., were as much as 50 to 70 feet below water levels west of the fault (pl. 12).

The trace of the Inglewood fault tentatively has been extended across the eastern part of the Beverly Hills on the basis of an eastward-facing escarpment about 70 feet high, trending N. 25° W., and alined with the fault trace across the Baldwin Hills. If the assumption is correct that this escarpment marks the surface trace of the northward extension of the Inglewood fault, the fact that there is no displacement of Recent beds, and that the strata of late Pleistocene (Palos Verdes) age are displaced, dates the last movement along this fault as occurring in latest Pleistocene time.

The northern limit of the Inglewood fault is not known. However, this shear zone does not extend to the older rocks in the Santa Monica Mountains.

#### FAULTS IN BALLONA GAP

Two faults in Ballona Gap that are not associated with the Newport-Inglewood uplift, but which have a strong influence on ground-water circulation, are the Overland Avenue and the Charnock faults (pls. 2 and 3*D*). Both faults have been located by well-log and water-

level data. They bound the east and west sides of a dropped block or graben. Both have been shown on the water-level contour maps of the Los Angeles County Flood Control District since 1938 (Baumann and Laverty, 1940, map 9).

The Overland Avenue fault, so named in this report because its inferred trace nearly coincides with Overland Avenue in Culver City, is about 6 miles long and trends N. 30° W. It extends from the southwestern part of the Baldwin Hills northwestward across Ballona Gap, and across the southwest lobe of the Beverly Hills (pl. 2). Logs of wells indicate that where it crosses section *D-D'* (pl. 3*D*) in sec. 12, T. 2 S., R. 15 W., the vertical displacement is about 30 feet, with the dropped block on the west.

The well logs and water-level data indicate the fault extends 1.5 miles northwest of the Beverly Hills lobe over a part of the small alluvial plain, which is tributary on the north to Ballona Gap. Also, hydrologic evidence supported by subsurface data, indicate that the fault extended southeastward across sec. 19, T. 2 S., R. 14 W. Logs of wells 2/14-19C1 and 19C2 on the west side of the fault, and well 2/14-18F2 on the east side, indicate a displacement of several tens of feet at the base of the water-bearing deposits.

Although the attitude of the Overland Avenue fault is shown to be vertical in plate 3*D*, the true direction and magnitude of the dip of the fault plane are not known.

For the past 15 years the water levels on the east side of the Overland Avenue fault have remained 60 to 100 feet above those on the west side; this fact indicates the effectiveness of the fault as a ground-water barrier (pls. 9-12).

The Charnock fault has been so named in this report because it passes immediately west of the Charnock well fields of the city of Santa Monica and the Southern California Water Co., in the NW¼, sec. 11, T. 2 S., R. 15 W. The fault trace trends about N. 35° W. (nearly parallel to the Overland Avenue fault) and extends from the north border of the El Segundo sand hills<sup>6</sup> across Ballona Gap and through the alluvial narrows between the Ocean Park plain and the Beverly Hills. Water levels in wells and well-log data indicate that the north end of the fault trends in a more northerly direction (about N. 5° W.).

The attitude of the Charnock fault is not known; it is shown to be vertical in plate 3*D* (as was done in the case of Overland Avenue and the Inglewood faults). The trace of the fault is concealed beneath deposits of Recent age for almost its full extent on plate 2, but the

<sup>6</sup> The California Division of Water Resources in its investigation for the adjudication concluded from additional information that the Charnock fault extends south to Redondo Beach Boulevard in the vicinity of Gardena and so describe it in their report (1962, p. 93 and pl. 4).



throw is as much as 140 feet at the base of the San Pedro formation, with the dropped block to the east.

Hydraulic discontinuity is apparent across the Charnock fault, as shown by water-level contours on plates 9-12. For example, in November 1945, water levels east of the fault were as much as 50 feet below sea level, and were about 40 feet below those on the west.

The absence of land-surface displacement along the Charnock and Overland Avenue faults suggests that movement along these faults has not taken place during Recent time. The "50-foot gravel" of Ballona Gap is not known to be cut by either of these faults and thus it is believed that they have not produced any barriers to movement of water in this aquifer. As noted earlier in this report, all observable displacement along faults of the Newport-Inglewood structural zone occurred before Recent time, although movement is still taking place at depth.

The marked hydraulic discontinuities across the Charnock and Overland Avenue faults are caused in part by displacement of the water-bearing deposits against impermeable silt and clay beds. However, it is probably true that cementation within the fault zones has been responsible for much of the effectiveness of these ground-water barriers.

#### GROUND-WATER HYDROLOGY

##### REGIONAL GROUND-WATER CONDITIONS

The coastal plain in Los Angeles County is divided into two distinct ground-water basins by the Newport-Inglewood uplift, which extends from Beverly Hills southeastward to Signal Hill and beyond into Orange County. To the northeast the main (or central) coastal basin covers about 500 square miles in Los Angeles and Orange Counties and currently (1948) yields about a third of a million acre-feet of ground water annually—about four-fifths of the water pumped from the entire coastal plain. To the southwest of the uplift, the west basin currently (1948) yields about 90,000 acre-feet a year, or about one-fifth of the total pumpage of ground water from the coastal plain.

At least three distinct bodies of ground water occur in these two basins. In downward succession they are: (1) a body of shallow unconfined and semiperched water which occurs in the upper part of the alluvial deposits of Recent age within the several gaps and inland beneath most of the Downey plain, also in the upper Pleistocene deposits beneath the Torrance plain and along the flanks of the uplift; (2) the principal body of fresh ground water, which occurs chiefly in the lower division of the alluvial deposits of Recent age, in nearly all the deposits of Pleistocene age, and in the uppermost part of the

underlying Pliocene rocks; and (3) a body of saline connate water underlying the principal fresh-water body throughout the area.

Within the coastal plain in Los Angeles County, essentially all the water currently withdrawn from wells is pumped from the principal water body. Accordingly, in following paragraphs a brief statement is presented to outline the occurrence and circulation of ground water in this body and to furnish a general background preliminary to the detailed discussion of ground-water occurrence in the west basin treated in following sections of the report.

The sediments in the main coastal basin in Los Angeles County consist chiefly of the coalescing alluvial fans of the Los Angeles River and the San Gabriel River (including the Rio Hondo) systems (pl. 1). The alluvial fans, which were laid down in a synclinal trough, comprise tongues and lenses of sand and gravel, interbedded with silt and clay. The lenses or tongues of gravel and coarse sand are largely the channel deposits of the major streams; the fine sand, silt, and clay are chiefly flood-plain deposits carried to the interstream areas during flood stage. Beneath most of the Downey plain the alluvial deposits are at least 1,000 feet thick, near the axis of the synclinal trough—along a line through Huntington Park and Santa Ana—the deposits are as much as 3,000 feet thick. Most of the alluvium was deposited in early Pleistocene time, thus forming the San Pedro formation.

During most of the Pleistocene epoch, the shore of the alluvial plain in this central reach was nearly parallel to a line between Watts and Los Alamitos. Here the alluvial-fan deposits interfinger with lagoonal deposits of low water-yielding capacity. In effect, these lagoonal deposits produce a partial lithologic barrier to the free coastward movement of the ground water. About a mile or two farther coastward, the lagoonal deposits merge with beach and shallow marine deposits—extensive, thick layers of sand and gravel that constitute the inland margin of the highly productive Silverado water-bearing zone. In the reach from the Baldwin Hills to Signal Hill, the Silverado water-bearing zone extends across the crest of the Newport-Inglewood uplift and southwest to the present coast thus underlying the greater part of the west basin.

Three highly permeable aquifers within the deposits of Recent age that overlie the Pleistocene deposits and locally extend to depths of as much as 100 to 150 feet below land surface are: (1) The Gaspur water-bearing zone, which extends from Whittier Narrows to Terminal Island; (2) the westerly arm of the Gaspur zone, which extends from the Los Angeles River Narrows to a juncture with the main Gaspur water-bearing zone at Compton; and (3) the "50-foot gravel," whose east end is in hydraulic continuity with the westerly arm of the Gaspur water-bearing zone, extends westward through Ballona Gap to the

ocean. (See pl. 8 for extent of these water-bearing zones of Recent age within the Torrance-Santa Monica area.)

These extensively continuous and highly permeable aquifers are not typical alluvial-fan deposits. They are trains of gravel and sand laid down in valleys eroded in the Pleistocene deposits and were deposited contemporaneously with a rise in sea level. They form unbroken ground-water arteries or conduits from the intake areas to the ocean—in fact, they extend inland beyond the intake areas of the coastal plain, and through the passes to the inland valleys. They range in width from 1 to 6 miles; the Gaspur water-bearing zone is at least 20 miles long.

The principal body of ground water is unconfined only within the intake areas, which extend a few miles coastward from the Whittier and Los Angeles Narrows. Most of the recharge to the principal body takes place in these areas of unconfined water, by influent seepage from the major streams, by penetration of rain and irrigation water, and by underflow from the interior basins. Also, since 1938 recharge has taken place by percolation from the spreading basins along the Rio Hondo and the San Gabriel River about 3 miles coastward from Whittier Narrows.

Under native conditions of circulation the ground water moved generally oceanward from the intake areas, but chiefly under confinement. Coastward, beyond the intake areas, beds of silt and clay intervene between the successive water-bearing members and cause hydraulic discontinuity between those members. Such discontinuities generally are slight within the intake areas but they become more extensive toward the Newport-Inglewood uplift. Movement of water is most rapid in the coarsest materials—such as the materials that constitute the Gaspur water-bearing zone of Recent age and the more permeable members of the San Pedro formation. Under the hydraulic gradients from 5 to 10 feet to a mile, which initially prevailed throughout much of the coastal plain, movement is comparatively rapid in coarse deposits. However, the movement, probably is not more than a mile every few years. Although movement is much slower through materials of finer texture, it probably takes place to some extent in all but the finest grained clay. Thus, the fresh water in the principal water body occupies and moves through a succession of water-bearing members that are contained in the vertical range of the alluvial deposits of Recent age and all the deposits of Pleistocene age. To a lesser extent, fresh water may move through the upper part of the Pico formation, but movement through these deposits presumably, is very slow.

The oceanward movement in the principal fresh-water body is greatly impeded along the Newport-Inglewood uplift. There, owing

to substantial barrier features (cemented fault zones), the impedance under native conditions was sufficiently effective to produce a belt of flowing wells (the artesian area of Mendenhall) extending inland to the intake areas and occupying nearly two-thirds of the main coastal basin (Mendenhall, 1905b, pl. 1). The hydrostatic head so developed cause very high pressure in early wells. In the famous Bouton wells 2 miles north of Signal Hill (drilled about 1895), sufficient pressure heads were reached to raise the water level in casings 80 feet above the land surface or about 150 feet above sea level. These high pressures caused substantial leakage from the deeper water-bearing zones by upward movement in fracture-zone conduits adjacent to the master faults. At several places along the uplift, perennial springs occurred at the inland side of the master faults. For example, in Inglewood and immediately inland from the Potrero fault, a spring is reported to have discharged water perennially into the head of Centinela Creek. This spring ceased to flow about 1900. Also, in Long Beach two perennial springs have been described (Brown, 1944, p. 2), both associated with and immediately inland from the faults of the Signal Hill uplift. These springs ceased to flow after pressure levels in the main coastal basin were lowered below land surface by increasing withdrawals.

Under natural conditions of high-water level inland from the uplift, a substantial part of the replenishment to the main coastal basin in Los Angeles County passed across the uplift as underflow into the west basin. This underflow moved coastward in the confined aquifers within the west basin, chiefly in the Silverado water-bearing zone of the Torrance-Inglewood subarea and in aquifers of correlative age to the north, but also in shallower Pleistocene aquifers, and in those of Recent age—the Gaspur water-bearing zone of Dominguez Gap and the "50-foot gravel" of Ballona Gap. In addition to the underflow, recharge from rainfall contributed to the ground-water supply of the west basin.

The Los Angeles River and Ballona Creek did not furnish recharge directly to the west basin under native conditions because they were effluent within its extent and hence functioned as channels for ground-water discharge. Most of the discharge, however, was by direct escape from the aquifers extending beneath the ocean. Such discharge was into Santa Monica Bay along the west coast from Santa Monica to the Palos Verdes Hills, especially southward from Redondo Beach; discharge also occurred into San Pedro Bay at the south end of Dominguez Gap, probably largely from the Gaspur water-bearing zone.

The pressure or piezometric surfaces of all aquifers in the west basin under native conditions were below the land surface everywhere

except (1) near the coast in Ballona Gap, and (2) locally in and near Dominguez Gap, as registered in four wells that were flowing in 1904. In Ballona Gap in 1904 the area of artesian flow as shown by Mendenhall (1905b, pl. 5) extended over about 3 square miles, chiefly in secs. 21, 22, 23, and 27, T. 2 S., R. 15 W. Within this area, almost the entire land surface is less than 10 feet above sea level.

The decline in water level which has occurred in the main coastal basin within the past three decades, has been nearly matched by a similar decline on the coastal side of the uplift (within the west basin); therefore, the local pressure differential has remained almost equal. However, the decline along the crest of the uplift has been many tens of feet; it has dewatered a part of the water-bearing conduits and the over-all escape from the main basin to the west basin has been decreased substantially. Thus, the changes in water level that occur within the main basin are critical in determining the quantity of replenishment that may be contributed to the west basin by underflow across the uplift.

For the main coastal basin and especially for the coastal reach from Dominguez Hill southeast to Newport Beach, the interpretive reports of the Geological Survey on the Long Beach-Santa Ana area have treated in some detail the occurrence and circulation of ground water, the increasing withdrawals, the drawdown of the water level that has developed, the nature and sources of saline contamination, and the character of the Newport-Inglewood uplift as a barrier to water movement. Other sections of this report will treat elements of somewhat similar scope within the west basin.

#### GROUND WATER IN THE WEST BASIN

##### SEMIPERCHED WATER BODY

###### OCCURRENCE

The semiperched and unconfined water body occurs rather widely in the west basin in deposits less than 100 feet below the land surface. It is the first water reached by wells but is utilized only locally. In Dominguez Gap it is contained within the upper 20-50 feet of the Recent deposits in layers of fine sand and silt of low permeability. In Ballona Gap it occurs in deposits of similar age and physical character, but here the semiperched body commonly does not extend more than 20 to 30 feet below the land surface. Beneath the Torrance plain, this body occurs very widely in the uppermost Pleistocene deposits. About in the south-central part of the Torrance plain, where it is tapped by nearly 100 wells, the semiperched body extends to depths of as much as 80-100 feet. Thus, here it is about twice as thick as within the two flanking gaps.

Although this water body has frequently been referred to as perched water in local usage, in reality it is semiperched. According to Meinzer (1923, p. 40-41),

ground water is said to be *perched* if it is separated from an underlying body of ground water by unsaturated rock [including unconsolidated material]. Perched water belongs to a different zone of saturation from that occupied by the underlying ground water. \* \* \* Ground water may be said to be *semiperched* if it has greater pressure head than an underlying body of ground water, from which it is, however, not separated by any unsaturated rock. Semiperched water belongs to the same zone of saturation as the underlying water, and therefore where it occurs there is only one water table, which may be called a *semiperched water table*. Semiperched water, like perched water, is underlain by a negative confining bed of either permeable or impermeable type. The underlying water has subnormal head.

Nearly everywhere within its extent in the west basin, the static level of the semiperched water body is higher than the pressure head of the underlying body of fresh ground water. Also, it is generally separated from the underlying water by more or less impermeable layers of silt and clay.

The semiperched water body beneath the Torrance plain is replenished principally by infiltration of rain and of runoff temporarily ponded by overflow from Dominguez Channel and by infiltration of irrigation water. Under native conditions in Dominguez Gap the semiperched body discharged to the Los Angeles River. For the last three decades, however, the water table has been at a lower altitude than the channel of the Los Angeles River, and the body is replenished in part by influent seepage from the river. Stream-gaging records are not adequate to define the small quantity of river loss involved but measurements in shallow wells show a ground-water mound beneath the river channel. Also, a study of saline contamination in Dominguez Gap has suggested that since about 1930 the average contribution of saline water from the Los Angeles River passing through the semiperched body to the Gaspur water-bearing zone has been at least 90 acre-feet per year (Piper, Garrett, and others, 1953, p. 190). Thus, it is inferred that the over-all annual recharge to the semiperched body has been substantially more than 90 acre-feet per year. In Ballona Gap under native conditions the ground-water body fed the creek along nearly the full reach of the gap. Within the west basin under the current conditions of depressed water level, the semiperched water doubtless has been and now is replenished in part by seepage from Ballona Creek. Immediately inland from the Inglewood fault, however, even though the pressure head in the underlying San Pedro formation has been drawn down below sea level since the early thirties (pls. 9-12), the semiperched water body is known to

have discharged water to Ballona Creek as late as 1932, from a spring in 2/14-5M (pl. 17, loc. 5).

#### UTILITY

Almost everywhere within its extent, the semiperched water was greatly inferior in chemical quality to the underlying fresh water under native conditions. Locally in Dominguez Gap, its quality has deteriorated substantially in the past two decades, either from landward movement of ocean water or by addition of industrial wastes and oil-field brines. The changes in chemical quality of the semiperched water in Dominguez Gap have been discussed at length in an earlier report (Piper, Garrett, and others, 1953, p. 173-177); the chemical quality of the semiperched water elsewhere in the west basin is discussed on page 175 of this report.

Because of the general inferior quality of the semiperched water, and because wells of large capacity cannot be obtained, little water is withdrawn from it. In Dominguez and Ballona Gaps, few wells produce water from this body. However, beneath the Torrance plain in the Gardena area, the semiperched water in the uppermost Pleistocene deposits is tapped by about 100 wells which range in depth from 25 to 100 feet. The area of this development is south of Rosecrans Avenue and north of 190th Street, and extends eastward from Hawthorne Avenue about 5 miles to Avalon Boulevard. From information obtained during the well canvass, it is concluded that about half of the wells, or about 50, are used chiefly for irrigation; of the remainder, some are used exclusively for domestic supply but most are used jointly for irrigation and domestic supply. Many of the wells are equipped with windmills. The yield of these wells commonly is only a few gallons per minute, and the irrigated gardens usually do not exceed half an acre in extent. Accordingly, it is estimated that the over-all draft from the 100-odd wells is about 50 acre-feet a year.

#### DECLINE OF WATER LEVEL

Throughout the known extent of the semiperched water body, its water table has declined 10 to 20 feet since 1904, the time of earliest record. For example, in Dominguez Gap in 1903-4—essentially under native conditions of head—the water table of the semiperched body ranged from 5 to 8 feet below land surface throughout the gap, and coincided closely with the pressure level of the underlying Gaspar water-bearing zone. In 1946 the depth to the water table ranged from 15 to 25 feet; and again it was about coincident with the pressure level in the Gaspar water-bearing zone. Thus, in about 40 years the water table of the semiperched body had declined as much as 10 to 15 feet in Dominguez Gap. Because a coincident decline occurred in the pressure level of the Gaspar water-bearing zone, it is concluded

that there is appreciable hydraulic continuity between the two water bodies. Because the pressure level in the Gaspar zone was drawn down by heavy withdrawals (especially in the twenties and early thirties), water percolated downward from the semiperched body and its level declined accordingly. This conclusion has been substantiated by study of the nature and development of saline contamination within the Dominguez Gap (Piper, Garrett, and others, 1953, p. 167-169).

In the Gardena area in 1904 the semiperched water table ranged from 10 to 25 feet below land surface about 15 to 25 feet above sea level. Since 1929 periodic measurements have been made in a few wells tapping the semiperched body in this area. (See hydrographs for wells 3/14-25E2 and 25K3, fig. 5.) The water table at or near these wells was 22 feet above sea level in 1904 (from Mendenhall); 15 feet in 1929; 12 feet in 1936; and 14 feet in 1945 (high level for each respective year). Thus, this water table has had a net decline of about 8 feet in 40 years. In 1904 the pressure levels in nearby wells tapping the "200-foot sand" and the Silverado water-bearing zone, respectively, were nearly coincident with the semiperched water table, but they have been drawn down progressively until in 1946 they were about 30 and 50 feet below the semiperched water table (fig. 5). Presumably, the 8-foot lowering of the water table in 3/14-25E has occurred in part by slow percolation from the semiperched body to the underlying aquifers. However, this change in storage in the semiperched body has been distributed over many years, and the containing deposits have a low specific yield.<sup>7</sup> Also, some part of the lowering may represent drawdown by withdrawals from the shallow wells of the Gardena area. For these reasons, change in storage in the semiperched body is considered to have been negligible in its relation to problems of replenishment to the principal water body.

#### PRINCIPAL WATER BODY

##### OCCURRENCE

##### EXTENT AND THICKNESS

The principal body of fresh ground water underlies almost all the Torrance-Santa Monica area, and occurs beneath all of the west basin except the crestal part of the Baldwin Hills and certain contaminated areas along the coast. It extends downward from the base of the semiperched water body to the top of the body of saline connate water. This fresh-water body occupies: (1) the lower division of the deposits of Recent age—that is, the Gaspar water-bearing zone

<sup>7</sup> The specific yield of a water-bearing deposit is defined as the ratio of (1) the volume of water which the saturated material will yield by gravity to (2) its own volume. This ratio is stated as a percentage.



and the "50-foot gravel" where these are uncontaminated; (2) the unnamed upper Pleistocene deposits, in which the principal aquifer is the "200-foot sand"; (3) the San Pedro formation of early Pleistocene age which, in the Torrance-Inglewood subarea, contains (a) an inextensive upper aquifer, the "400-foot gravel", and (b) the underlying thick and very extensive Silverado water-bearing zone; and (4) most of the upper division of the Pico formation of late Pliocene age, except in the Culver City area where the sand members in the upper division of the Pico either are absent or, if present, commonly contain brackish to saline waters.

The depth to the base of the principal fresh-water body has been shown on plate 8. Its over-all thickness is indicated generally by the contours of that map because its top is within a few tens of feet of sea level in almost all of the west basin except along the crest of the Newport-Inglewood uplift and along the flank of the Santa Monica Mountains where its top rises to as much as 200 to 300 feet above sea level.

The upper division of the Pico formation is not tapped by water wells at the present time. Hence, the thickness of the principal water body now utilized is indicated by the contours drawn on the base of the water-bearing deposits of Pleistocene age (pl. 2). In the Torrance-Inglewood subarea, these contours define the base of the Silverado water-bearing zone; in the Culver City subarea, they define the base of the essential correlative of the Silverado water-bearing zone—that is, the main water-bearing zone within the San Pedro formation. As shown by that map, throughout much of the west basin the thickness ranges from 200 to 700 feet but it reaches a maximum of about 1,200 feet near the intersection of Alameda and Carson Streets in Dominguez Gap, at the deepest part of the syncline.

Along the crest of the Newport-Inglewood uplift the thickness of the water-bearing deposits now tapped by wells varies widely. As shown by plate 3A, the thickness ranges from a feather edge on the crest of the Baldwin Hills to 700 feet in Dominguez Gap. Specifically, along the line of section A-A' (pl. 3A), these water-bearing deposits are about 330 feet thick in Inglewood, thin to 250 feet at the north end of the Rosecrans Hills, thicken irregularly southeastward to about 600 feet at the south edge of the Rosecrans Hills and beneath the crest of Dominguez Hill, attain a maximum thickness of 700 feet in Dominguez Gap, and thin to about 200 feet beneath Signal Hill.

Along the coast the thickness of the water-bearing deposits tapped by wells is somewhat more uniform although it increases substantially from north to south (pl. 3C). These deposits are from 200 to 250 feet thick from Santa Monica to Playa del Rey, thicken to as much as 350 feet at El Segundo, thin to 200 feet at Manhattan Beach, thicken

to 500 feet in the Redondo Beach area, and then thin to a featheredge along the north flank of the Palos Verdes Hills. The thicknesses here cited do not include the deposits of dune and beach sand that blanket the coast from Playa del Rey to the Palos Verdes Hills and extend from a few tens of feet above sea level to altitudes as much as 244 feet.

For the several water-bearing zones within the principal water body, general physical character, water-bearing character, extent, thickness, and depth below land surface have been discussed in the geologic section of this report. The quantity of water withdrawn from them is discussed on pages 99-111.

#### CONFINED AND WATER-TABLE CONDITIONS

Within most of the west basin, the water-bearing zones within the principal water body are separated by substantial thicknesses of relatively impermeable silt or clay. These features have been shown on the geologic sections previously introduced. The beds of silt or clay confine the water in the several aquifers and prevent free circulation from one to another. For example, between Hawthorne and Gardena, near the axis of the syncline, along the line of section *B-B'* (pl. 3*B*), the "200-foot sand" is separated from the "400-foot gravel" by 50 to 100 feet of silt or clay; and a similar thickness of silt or clay separates the "400-foot gravel" from the Silverado water-bearing zone beneath.

In the Torrance-Inglewood subarea, the water in the several aquifers is almost wholly confined by impermeable deposits, except to the south of Playa del Rey and near Redondo Beach (pl. 11), where a water table occurs. Near Playa del Rey, the water table is in the main water-bearing zone of the San Pedro formation; the top of this water-bearing zone here rises as high as 30 feet above sea level and the confining beds feather out westward in the vicinity of Lincoln Boulevard. West of Lincoln Boulevard and south nearly to Imperial Highway, the main water-bearing zone is directly overlain by permeable beach and dune deposits. Hydrographs introduced later in this report suggest that rainfall passes through these overlying permeable beds directly into the main water-bearing zone (p. 124).

In the Redondo Beach area, south of 190th Street (boundary between Tps. 3 and 4 S.) and west of the center of the city of Torrance, the confining beds that separate the Silverado water-bearing zone and the "200-foot sand" to the east and north are not present (pl. 5). In this area the permeable deposits of Pleistocene age rise above sea level and a water table occurs in what is inferred to be the Silverado water-bearing zone, although its upper part may represent the westward extension of the "200-foot sand."

In the area south of Sepulveda Boulevard and east of Narbonne Avenue, water-table conditions exist in the "200-foot sand," extend eastward about to Alameda Street and beneath much of the Wilmington area. Here, however, the "200-foot sand" is separated from the Silverado water-bearing zone by relatively impervious deposits and from west to east the water table in the "200-foot sand" stands progressively higher than the pressure surface of the Silverado zone.

Elsewhere within the Torrance-Inglewood subarea, the ground water in the Silverado water-bearing zone is wholly confined and in the "200-foot sand" it usually occurs under confined conditions.

In the Culver City subarea the water in the main water-bearing zone of the San Pedro formation commonly is confined, except locally along the north edge of Ballona Gap from the Charnock fault west to the coast, in the Charnock subbasin north of the Charnock well fields, and from the Overland Avenue fault east at least to and beyond the wells in 2/15-1C (pl. 2).

#### SOURCE AND MOVEMENT

#### METHOD OF INVESTIGATION

The source of ground water commonly is indicated by the direction of movement. Water generally moves from areas of recharge to areas of discharge. If the water-bearing deposits are homogeneous, the altitude of water level in a number of wells measured within a short span of time can be utilized to construct a map showing contours on the water table or the piezometric surface. Such a map shows conditions of head from place to place. Movement is at right angles to the contours, which connect points of equal altitude on the water table or the piezometric surface. The rate of movement is proportional to the hydraulic gradient and the permeability of the deposits.

As already discussed, the water-bearing deposits in the west basin do not occur as a homogeneous permeable mass but are stratified in several fairly distinct aquifers which are separated at most places by confining layers. Initially the pressure levels in all the water-bearing zones were at about the same altitude. Through the period of use, and largely because of inequalities in draft and replenishment, differences have developed in the pressure levels of the several aquifers. At some places, the maximum differential in water level in shallow and deep aquifers in 1946 was as much as 70 feet. Thus, in order to draw contours on the piezometric surface or water table for a single aquifer, only levels for wells tapping that aquifer can be utilized. A water-level contour map drawn from levels in random wells tapping more than one aquifer would be misleading and inac-

curate and could not be used to determine direction of movement, or source of water.

Within the west basin, the Silverado water-bearing zone south of the Ballona escarpment and its essential correlative to the north currently yield about 90 percent of the ground-water withdrawal, including nearly all the pumpage for industrial use and about 90 percent of the pumpage for domestic use. Thus, with respect to conditions of replenishment and saline contamination, the changes in the form and position of the piezometric surface in these composite water-bearing zones of the San Pedro formation are critical, and the changes in water level in overlying aquifers are of minor importance.

Water-level contour maps showing conditions in 1903-4 and in March 1933 (pl. 9), in April 1941 (pls. 10, 11), and in November 1945 (pl. 12), have been included in this report. Each of these water-level contour maps has been drawn from water-level altitudes in wells tapping the San Pedro formation—that is, the water-bearing zones most intensively utilized. Within almost all the Torrance-Inglewood subarea, the water levels utilized for the maps were those in wells tapping the Silverado water-bearing zone; in the Culver City subarea the water-level data were from wells tapping the main water-bearing zone of the San Pedro formation, the essential correlative of the Silverado water-bearing zone; and inland from the west basin, water levels were from the deeper wells tapping the Silverado or equivalent water-bearing zones of Pleistocene age.

In preparing the water-level contour maps, measurements of depth to water were utilized from all possible sources. For the maps of 1933 and 1941, measurements were made chiefly by the Los Angeles County Flood Control District and by the Los Angeles Department of Water and Power; for the map of 1945, most of the measurements were made by the Flood Control District and by the Geological Survey. All measurements made by the Geological Survey during the cooperative investigation are being published in the annual reports on water levels and artesian pressure in the United States for the years 1944, 1945, and 1946 (U. S. Geol. Survey). The scope of the measurements is discussed on page 112.

Altitudes of measuring points for most of the observation wells in the Torrance-Santa Monica area have been determined by instrumental leveling. For the area immediately west of Long Beach, in T. 4 S., R. 13 W., altitudes for many of the wells were determined by the Geological Survey in 1941-42 through a third-order level net anchored to bench mark "tidal 8" in the Los Angeles Outer Harbor, and by additional levels with transit and stadia or with alidade and level rod, tied to the third-order net (Meinzer, Wenzel, and others, 1944, p. 87-88). In the remainder of the area, altitudes of measur-

ing points for most of the observation wells have been determined by levels of the Los Angeles Department of Water and Power, and these were utilized wherever available. For a few wells, altitudes of measuring points have not been determined instrumentally; however, these altitudes have been interpolated from topographic maps of the Geological Survey having a 5-foot contour interval.

#### MOVEMENT IN THE TORRANCE-INGLEWOOD SUBAREA

*Conditions in 1903-4.*—Water-level contours for 1903-4 are plotted on plate 9 for the southern two-thirds of the project area—essentially the Torrance-Inglewood subarea. These contours were constructed from data obtained by Mendenhall and show substantial modification from his water-level contours (Mendenhall, 1905b, pl. 5). The revision has developed for two reasons: (1) The altitude of land surface at the wells measured during the Mendenhall field canvass has been re-interpolated because of recent Geological Survey topographic maps with a land-surface contour interval of 5 feet; in the Torrance area especially, the topography on the later map (1934 edition) differs considerably from that shown by the survey of 1894, which was published with a land-surface contour interval of 25 feet and was the basis for the well altitudes interpolated by Mendenhall. (2) Insofar as possible, only water levels in wells tapping the Silverado water-bearing zone have been utilized in redrawing the water-level contours, whereas the contours of Mendenhall were generalized from all available water levels, including many levels for wells tapping shallower zones.

The reconstructed water-level contours of 1903-4 show coastward movement of ground water across the Newport-Inglewood uplift and a hydraulic discontinuity from about 40 to 50 feet across the inland boundary of the west basin along the 14-mile reach from the Baldwin Hills to Long Beach. Within the west basin movement was also generally coastward. East of Manhattan Beach the 20-foot contour bulges seaward, indicating a flattening of the hydraulic gradient and a diversion of part of the ground-water flow to the northwest and to the south. This configuration of the pressure surface suggests that the known thinning of the Silverado water-bearing zone near the coast at Manhattan Beach (fig. 2) retarded discharge of ground water to the ocean. However, in the vicinity of Manhattan Beach, the dune topography is rough and hilly; and the locations of the wells shown by Mendenhall can be plotted only approximately on the revised topographic map of the Torrance quadrangle. Hence, the computed altitude of the water surface is subject to possible errors of several feet and the contours based on these altitudes are only approximations and are not suitable for exact interpretations.

From Manhattan Beach northward to Playa del Rey, the movement of ground water was westward; inland from Sepulveda Boulevard the coastward gradient was from 6 to 8 feet per mile. Near the coast, however, the gradient was only about 3 feet per mile.

Southward from Manhattan Beach to the Palos Verdes Hills, the movement was generally westward to the coast; from the Palos Verdes Hills to Long Beach the movement was southward. The coastward gradient in 1903-4, both westward toward Redondo Beach and southward toward San Pedro Bay, was about 4 feet per mile.

Thus, the contours of 1903-4 suggest escape of ground water beneath the ocean offshore from Redondo Beach and beneath San Pedro Bay. Although fresh-water springs were reported in San Pedro Bay, under native conditions, these are believed to have developed by escape of water from the ocean-bottom outcrop of the Gaspur water-bearing zone (Poland, Piper, and others, 1956, p. 50). However, escape from the Silverado water-bearing zone under native conditions by upward movement into San Pedro Bay cannot be substantiated by such direct evidence. The writer has heard reports of former fresh-water springs offshore from Redondo Beach but these have not been verified. If such springs did occur, they must have been fed by discharge from the Silverado zone.

From the geologic relations, it would seem that escape could have occurred with much greater facility in the vicinity of Redondo Beach than beneath San Pedro Bay (pls. 5 and 6). If the permeability of the Silverado water-bearing zone is assumed to be about 1,300 gpd per square foot (about two-thirds as great as in the area east of Torrance, as indicated by comparison of yield factors from table 5), the oceanward discharge in the Redondo Beach area under native conditions can be estimated by use of the equation

$$Q=P_f \times I \times A,$$

where  $Q$  is gallons per day;  $P_f$  is the field coefficient of permeability defined as the number of gallons of water per day that would be conducted through each mile width of the water-bearing bed for each foot of thickness of the bed and for each foot per mile of hydraulic gradient;  $I$  is the hydraulic gradient in feet per mile; and  $A$  is the cross-sectional area of the water-bearing material in foot-miles. The average thickness of the Silverado water-bearing zone between Hermosa Beach and the Palos Verdes Hills is about 400 feet and the distance about 3.5 miles; thus the estimated discharge  $Q=1,300 \times 4 \times 400 \times 3.5$ , or about 7.3 mgd, equivalent to about 11 cfs. The presumed gradient of 4 feet to the mile at Redondo Beach is conservative; coastward from the 10-foot water-level contour, a steeper gradient is

suggested by the altitudes of water level in random wells. Because the local control is poor, however, the regional coastward gradient of about 4 feet per mile was utilized in computing the estimate for seaward escape in the Redondo Beach area as of 1903-4. Thus, the annual discharge to the ocean between Hermosa Beach and the Palos Verdes Hills in 1904 is estimated to have been about 8,000 acre-feet per year.

North from Hermosa Beach to Playa del Rey and along San Pedro Bay the data on gradient near the coast in 1903-4 are fragmentary but a rough estimate of oceanward discharge is given on page 147.

*Conditions in 1933.*—The withdrawals of ground water from the Torrance-Inglewood subarea increased from an estimated 10,000 acre-feet per year in 1904 to about 50,000 acre-feet per year in the early thirties (p. 99-100). The water-level contours for March 1933 (pl. 9) show the changes in position of the water level and in direction of movement that had developed since 1904 as a result of increasing withdrawals from the west basin and from the main coastal basin to the northeast. These changes can be summarized as follows:

1. Immediately inland from the west basin boundary, in the reach from the Baldwin Hills to Long Beach, the water levels had declined about 40 feet in the 29 years but the direction of movement was still coastward into the west basin. The local gradient had been steepened to a small degree. (See also pl. 4 showing water-level profiles for 1904 and 1930.)

2. The pressure differential across the fault boundary ranged from about 30 feet at Inglewood and Dominguez Gap to about 50 feet in the central part of the Rosecrans Hills.

3. Within the area south of Inglewood the pressure level—and, locally, the water table—was below sea level. Everywhere westward from the axis of the pressure trough, about two-thirds of the Torrance-Inglewood subarea, the direction of movement of the water within the Silverado zone had been reversed and was landward—generally southeastward or eastward toward the area of greatest pressure lowering in Dominguez Gap.

*Conditions in 1941 and in 1945.*—Plate 11 shows water-level contours for April 1941 and plate 10 indicates the rise or fall in water level that had occurred since March 1933 (pl. 9). The general pattern of the contours is similar to that for March 1933. However, attention is directed to four features:

1. The maximum drawdown of water levels in the 8-year period occurred immediately inland from the west basin boundary, east of Inglewood and within the Rosecrans Hills, and was about 30 feet. This drawdown, indicating local overdraft, was noteworthy because almost everywhere else within the main coastal basin (central basin), except in the Huntington Park area, water levels were higher in 1941 than in 1933.

2. In the west basin, north of 190th Street, nearly all water levels were drawn down, but the maximum decline of 16 feet, which developed between Inglewood and Hawthorne, was only about half as great as the drawdown inland beyond the west basin boundary.

3. South of 190th Street, water levels changed only a few feet between 1933 and 1941. In the Wilmington area, a small net rise resulted from the virtual cessation of pumping at the Wilmington and Lomita well fields of the city of Los Angeles (table 7).

4. The axis of the pressure trough moved inland as much as 3 miles between Hawthorne and Gardena, but it was almost stable from 190th Street into Dominguez Gap. This axis marks the boundary between coastward and landward movement of ground water in the Silverado water-bearing zone.

Largely because of demands caused by industrial expansion during the war years, withdrawal of ground water from the Torrance-Inglewood subarea increased about 50 percent between 1941 and 1945 (table 8). The water-level contours of plate 12 indicate conditions in November 1945, essentially at the end of the period of acceleration in draft induced by the war expansion, in relation to distribution of pumping draft.

The contours represent approximate low-water levels for the year, whereas the contours for 1933 and 1941 represent the high-water levels in those years. As is shown on representative hydrographs introduced later in this report, the yearly fluctuation in the Silverado water-bearing zone within the west basin ranges from about a foot near the coast to as much as 30 feet in areas of heavy pumping near the inland boundary. For example, the center of the depression in the piezometric surface immediately north of Hawthorne was 62 feet below sea level in November 1945, but it was only 38 feet below sea level in March 1945 (pl. 13, well 3/14-4N1). Thus, although the contours for November 1945 indicate a maximum decline of more than 30 feet below the contours for April 1941 (pl. 11), much of this is due to seasonal fluctuations. The contours of November 1945 were drawn to show the lowest water levels for the Silverado water-bearing zone that had occurred in the Torrance-Inglewood subarea to the end of 1945. With respect to saline encroachment from the ocean, the average controlling hydraulic gradient is about halfway between the seasonal high and low levels. However, the maximum rate of landward advance of the saline front occurs at the time of autumn low water. In November 1945, the landward gradient from the coast to the minus 20-foot contour was steepest between El Segundo and Hermosa Beach, as much as 20 feet per mile; in the vicinity of Redondo Beach it was only about a third as steep, from 5 to 6 feet per mile.

The axis of the pressure trough did not move appreciably from 1941 to 1945, even though pressure levels along that axis were drawn down locally as much as 30 feet. In November 1945, the greatest differential pressure across the inland boundary of the west basin was about 60 to 70 feet. Differential pressures of this magnitude occurred east of Inglewood across the southern part of the Potrero fault, also in Dominguez Gap across the Cherry-Hill fault.



## MOVEMENT IN THE CULVER CITY SUBAREA

*Summary of geologic features.*—Ballona Gap, a broad trench cut into the Pleistocene deposits by an ancestral Los Angeles River, is floored by deposits of Recent age to a depth of 40 to 80 feet below land surface. These deposits consist of an upper and a lower division. The upper division consists chiefly of clay, silt, and fine sand; it is from 10 to 40 feet thick and of low permeability. The lower division, the "50-foot gravel," is composed almost wholly of gravel, but locally contains lenses of coarse sand. Its thickness ranges from 10 to 40 feet and its average base is about 50 feet below land surface. The "50-foot gravel" blankets most of the gap (pl. 8) and furnishes a thin but permeable ground-water artery from the main coastal basin to the ocean.

Everywhere within the gap, the "50-foot gravel" is presumed to be underlain by the San Pedro formation. Near the coast, the San Pedro largely consists of sand and gravel; but inland beyond the Inglewood fault more than half the formation is made up of layers of silt and clay, which separate and confine the layers of sand and gravel (pl. 3D). Within and adjacent to Ballona Gap, three faults divide the San Pedro formation into distinct blocks which are critical with respect to water circulation and to movement of contaminated waters. These three faults are subparallel and trend about north-northwest. So far as known, they do not transect the deposits of Recent age and presumably do not interrupt hydraulic continuity in the "50-foot gravel." (See p. 76 and 78.)

Of the three faults, the Inglewood fault, the farthest inland, passes across the gap about 6 miles from the coast and forms the inland boundary of the west basin in this area. The Sentney plant of the Southern California Water Co. (in 2/14-5D) is a short distance east of this fault and within the main coastal basin. Logs of wells at this plant show that three distinct aquifers in the San Pedro formation yield water to wells and that the three are separated by impervious strata.

The Overland Avenue fault is about 2 miles coastward from the Inglewood fault. Between these two faults, an upthrown block of the San Pedro formation contains water-bearing beds whose thickness ranges from 50 to 100 feet. The subbasin within this block is termed the crestal subbasin.

The Charnock fault is about 1.2 miles west of the Overland Avenue fault and 3 miles from the coast. Between these two faults the San Pedro formation has been dropped and the main water-bearing zone is as much as 350 feet thick. In subsequent discussion, the subbasin within this block will be referred to as the Charnock subbasin. Coastward from the Charnock fault the San Pedro formation is gently

folded and its water-bearing deposits range from 100 to 250 feet in thickness.

Logs of wells indicate that the "50-foot gravel" and the underlying water-bearing deposits of the San Pedro formation are in direct contact locally within each of the blocks here described, and thus, some hydraulic continuity occurs. The complex structure of the San Pedro formation makes it difficult to trace the extent of hydraulic continuity, except where logs of closely spaced wells are available. However, the hydraulic continuity is known to be most free coastward from the Charnock fault, and is very poor to absent inland from the Overland Avenue fault.

North of Ballona Gap, logs of wells show a general southerly dip of the water-bearing beds of Pleistocene age, but the sand and gravel layers are irregular in thickness and position and cannot be correlated from well to well. Only within the dropped Charnock subbasin (to the north), are the water-bearing deposits thick and extensive. The main water-bearing zone extends continuously at least 2 miles north from the gap, to the vicinity of Pico Boulevard, where its top is about 50 feet above sea level and its thickness about 250 feet.

*Circulation of ground water.*—The Culver City subarea has been defined as including the part of the west basin north of the Ballona escarpment. The ground-water contour maps of the west basin for the selected times between 1904 and 1945, inclusive, indicate that exchange of ground water between the Culver City subarea and the Torrance-Inglewood subarea—that is, across the Ballona escarpment—has been small. Also, in the Culver City subarea, movement has been controlled very largely by fault barriers, which appear to partition the subarea into three essentially separate subbasins. Within these subbasins, movement has been chiefly in response to concentrations of draft at several heavily pumped well fields (pl. 12).

Water-level contours for the Culver City subarea for 1903-4 were reconstructed from basic data by Mendenhall but it was impracticable to reproduce them on plate 9, because of the complexity of the hydrologic pattern for 1933. However, a brief summary of salient features is presented. These contours indicate that in 1903-4 there was a general southward movement of ground water toward Ballona Gap from the upland area flanking the Santa Monica Mountains. In Ballona Gap the contours were drawn chiefly from water levels in shallow wells tapping the "50-foot gravel" because in 1904 very few wells had been drilled to the San Pedro formation below. Here the movement of water was southwestward and essentially parallel with the slope of the land surface. In Ballona Gap, a short distance west of the Inglewood fault, the water-level contours bulge coastward, indicating that water in the "50-foot gravel" was moving coast-

ward from the main basin into the west basin, over the top of the Inglewood fault. Throughout its 6-mile reach within the west basin Ballona Creek was an effluent stream draining water from the Recent deposits of the gap. The reach of effluent seepage extended inland at least half a mile beyond the Inglewood fault and into the area of artesian flow that still existed in 1904 in the main coastal basin.

The water-level contours for March 1933 (pl. 9), April 1941 (pl. 11), and November 1945 (pl. 12), show general similarity in direction of ground-water movement; and all show substantial change from the water-level contours of 1903-4. This change was brought about by (1) heavy draft from well fields in or adjacent to the two sub-basins, and (2) the barrier action of the three major faults, which bound those subbasins.

In the main coastal basin, immediately inland from the Inglewood fault and adjacent to Washington Boulevard, heavy withdrawals from the wells at the Sentney plant of the Southern California Water Co. in sec. 5, T. 2 S., R. 14 W., and from nearby wells of the city of Beverly Hills (Cadillac and Castle plants) had developed a substantial cone of pressure relief by the early thirties. In March 1933, the pressure level at the center of this cone as represented by the hydrograph for well 2/14-5D5 (pl. 14), was about 10 feet above sea level; but by April 1941 it had been drawn down as much as 60 feet below sea level. By 1945 local draft by the city of Beverly Hills had decreased and the water level in the spring of that year at well 2/14-5D5 had recovered substantially; but it was still 30 feet below sea level. Thus the pressure levels at these well fields have been maintained many tens of feet below sea level continuously for the past decade and water in the aquifers of the San Pedro formation has been moving into this cone of depression from the south, east, and north.

*Crestal subbasin.*—In the crestal subbasin, between the Inglewood and Overland Avenue faults, the movement of water in the San Pedro formation has been consistently southward from the Beverly Hills through 1945. Within this subbasin pumping draft is largely from wells at the Manning plant of the Southern California Water Co. in 2/15-1C and from well 2/15-12B1 of the Metro-Goldwyn-Mayer Corp. (pl. 2). Total draft from this subbasin is believed not to have exceeded 1,600 acre-feet per year. Under native conditions and continuously through the period of withdrawal, replenishment to the San Pedro formation in the crestal subbasin apparently has been supplied almost entirely by runoff from the south flank of the Santa Monica Mountains and by rainfall from the Santa Monica plain. However, in Ballona Gap north of Washington Boulevard, the water-bearing beds of the San Pedro formation are believed to be in direct contact locally with the overlying "50-foot gravel." Hence, ground

water passing westward across the Inglewood fault in the "50-foot gravel" may contribute some replenishment to the underlying San Pedro beds in the crestal subbasin. Within this subbasin, the position of water level in the "50-foot gravel" is not known, except at well 2/15-1P2 near the western boundary; here the water level in this aquifer has been about 30 feet lower than the pressure level of the San Pedro formation for the past 15 years. (See hydrograph for well 2/15-1P2 on fig. 4; pressure levels for San Pedro formation, pls. 9-12.) Thus, near this well, for many years the pressure differential between the two aquifers would not have permitted downward movement from the "50-foot gravel" to the San Pedro formation—if hydraulic continuity exists at all, movement would have been upward.

*Charnock subbasin.*—In the Charnock subbasin, during the past two decades at least, pumping has been concentrated at the Charnock plant of the city of Santa Monica (2/15-11C), and at the Charnock plant (2/15-11D, E, F) and the Sepulveda plant (2/15-11J) of the Southern California Water Co. The joint withdrawal from these three plants was 7,352 acre-feet in 1933, reached a maximum of 10,448 acre-feet in 1940, and was 7,258 acre-feet in 1941 and 5,005 acre-feet in 1945. The decrease in withdrawal was caused by the gradual decrease in the rate of pumping at the Charnock plant of the city of Santa Monica following 1940 and the complete cessation of pumping by the city late in 1944.

As a result of the concentrated withdrawal at the Charnock well fields and at the nearby Sepulveda well field, the water level in the San Pedro formation has been depressed several tens of feet below sea level since the late twenties. As shown by the water-level contours for the years 1933, 1941, and 1945 (pls. 9-12), and by other data, movement of ground water throughout the subbasin has been toward this focus of withdrawal for the past two decades. To the north (nearly to Pico Boulevard), water levels have been below sea level consistently since 1933, and the steep southward gradient induced by this draft has been as much as 50 feet to the mile (pl. 11). To the south (to and beyond the Ballona escarpment), water levels have been below sea level consistently since 1933, and the average northward gradient has been as much as 25 feet per mile (pl. 11). Thus, at least since 1933, about two-thirds of the water withdrawn from these well fields has come from the north and about one-third from the south. The water-level contours for the San Pedro formation indicate that very little water enters the Charnock subbasin from the east (across the Overland Avenue fault), or from the west (across the Charnock fault), even though the pressure differentials across the two faults have been as much as 110 feet and 90 feet (pl. 11).

The "50-foot gravel" may conduct some water into the Charnock subbasin, from both the east and the west. As shown by geologic section *D-D'* (pl. 3*D*), the "50-foot gravel" is in contact (at least locally) with the water-bearing beds of the San Pedro formation within the Charnock subbasin, and presumably some downward percolation of water occurs. However, fragmentary records of water levels in shallow wells indicate that in the part of the subbasin north of Ballona Creek, the "50-foot gravel" has been essentially dewatered for the past two decades. Southward from Ballona Creek, the base of the "50-foot gravel" locally is as much as 60 feet below sea level, and this water-bearing zone still must be almost wholly saturated.

*Coastal area.*—Between the Charnock fault and the coast, the "50-foot gravel" of Ballona Gap and the underlying main water-bearing zone of the San Pedro formation are in contact at many places, as shown by logs of wells. Thus, these water-bearing zones may have fair hydraulic continuity (p. 127). The water-level contours of 1903-4 indicate a general oceanward movement of water through these deposits, with a coastward hydraulic gradient of about 10 feet per mile. North of the gap, the water-level gradient was southward, indicating some replenishment from the Santa Monica upland area.

By the late twenties water levels in this coastal part of Ballona Gap had been drawn down as much as 10 to 30 feet and were from 5 to 15 feet below sea level (see pl. 9 for levels in 1933). The water-level contours of March 1933 indicate some continuing contribution from the north, but the underflow to the gap from beneath the Ocean Park and Santa Monica plains must be small because: (1) the water-bearing deposits are thin, and (2) southward movement is impeded by the ground-water barrier about at the north edge of T. 2 S., which is inferred to be a fault zone. Water levels in the gap had recovered to sea level by 1941, probably in part because of the heavy rainfall of that year but chiefly owing to a general decrease of draft for irrigation and cessation of pumping by the Marine plant of the city of Santa Monica in 2/15-9N; both actions were caused by saline encroachment. However, from the early thirties to date, the water level in this coastal part of the gap has been essentially flat and movement of water apparently has been largely in response to local draft. Except for withdrawals from the Marine plant to which reference has been made, that draft has been moderate and widely distributed. Because water levels were below sea level from the middle twenties through the thirties, sea water has advanced inland beyond Lincoln Boulevard and about half the distance from the coast to the Charnock fault (p. 197).

## WITHDRAWAL OF GROUND WATER

## HISTORY OF DEVELOPMENT

Development of ground water in the coastal plain began about 1870. As of 1904, Mendenhall (1905a, 1905b, 1905c) canvassed and described about 8,200 wells within the coastal plain, of which about 2,500 were flowing in the spring of 1904. Mendenhall estimated that in 1904, the average discharge of all flowing and pumped wells within the coastal plain was about 250 cfs, equivalent to a yearly withdrawal of about 180,000 acre-feet. He did not evaluate withdrawals from the west basin specifically. However, in 1904 there were 134 wells with pumping plants in the west basin, as compared to 282 wells with pumping plants in the Santa Monica and Redondo quadrangles (Mendenhall, 1905b, pls. 5 and 6). The average annual yield of all pumped and flowing wells in these two quadrangles was estimated as about 30,000 acre-feet. If the estimated yield is distributed in proportion to the number of wells with pumping plants, the withdrawals in 1904 were about 14,000 acre-feet per year for all the west basin, and about 10,000 acre-feet per year from the part of the west basin south of Ballona Gap—the Torrance-Inglewood subarea of this report. Because the lands irrigated by ground water within the Santa Monica and Redondo quadrangles amounted to only 12,250 acres in 1904, Mendenhall's over-all figure of 30,000 acre-feet probably is liberal (about 2.5 acre-feet per acre); thus, the estimate of 14,000 acre-feet just derived for the west basin likewise is also believed to be liberal.

During the quarter century following the canvass by Mendenhall, the rate of withdrawal from the west basin increased several fold, owing to: (1) increased demand for water for irrigation, industrial, and domestic use, (2) lack of surface-water sources, and (3) improvement and widespread use of deep-well turbine pumps. Information is not available to indicate the rate at which the withdrawal increased from 1904 to 1930. However, extensive industrial development commenced in the twenties, and water levels in wells tapping the Silverado water-bearing zone began to decline noticeably in the early to middle twenties. Also, a period of low rainfall began about 1919 (table 2), causing an increase in the use of water for irrigation. Thus, it is inferred that the over-all increase in draft was most rapid after 1919. Furthermore, the figures for electrical energy sold on the "agricultural-rate" schedule in the Redondo and Inglewood operating districts of the Southern California Edison Co. are available for the period beginning in 1923. In comparison with the amount of energy sold in 1932, as a base year (p. 104), the amount of energy sold annually in these two operating districts of the Edison Co. from 1923

through 1930 was higher in all years except 1927. The average use in the 8 years was 112 percent of the use in 1932; the peak was in 1923—about 140 percent of the 1932 base. Although water levels in the west basin declined nominally in the twenties, it is believed that pump efficiencies were improved sufficiently to nearly compensate for the increased lift, and that the amount of electrical energy required to raise an acre-foot of water remained nearly constant. Thus, it is concluded that the draft for irrigation in the Torrance-Inglewood subarea was slightly greater from 1923 through 1930 than in 1932 and following years (table 8). Accordingly, the main increase in irrigation draft must have occurred prior to 1923.

As indicated in table 8, by 1931 the withdrawal from the Torrance-Inglewood subarea was about 53,000 acre-feet per year, which indicates an increase of nearly 400 percent in the 26-year period since 1904. Records of withdrawal by the larger plants since 1931 are reasonably complete, and the withdrawal for irrigation and miscellaneous uses can be approximated with fair accuracy. Methods of evaluating this withdrawal are discussed in following pages, and estimates for the yearly over-all draft from the Torrance-Inglewood subarea beginning in 1931 are summarized in table 8.

#### PUMPAGE FROM MUNICIPAL WELL FIELDS

In 1945, eight cities operated municipal water systems within the Torrance-Santa Monica area. The well fields of the cities of El Segundo, Hawthorne, Manhattan Beach, Santa Monica, and Torrance are located within the west basin. The city of Santa Monica, however, purchased most of its water supply from the Metropolitan Water District, beginning in 1941, and reportedly discontinued the use of its well fields entirely in 1945. The city of Inglewood operated several well fields within the west basin and one (the Centinela Park well field) that was almost entirely in the main coastal basin. The city of Los Angeles operated its Lomita and Wilmington plants, which were within the west basin, and its Manhattan, 99th Street, and Figueroa Street plants in the main coastal basin. In 1945, the city of Beverly Hills pumped all of its water from well fields outside the west basin, partly from the main coastal basin and partly from the Hollywood basin of Eckis (1934, pl. *E*). In addition to these eight municipal systems, Los Angeles County Water Works Districts 13 and 22 withdrew water from plants wholly within the west basin. The distribution of plants producing more than 200 acre-feet of water for public supply or for industrial use in 1945 is shown on plate 12 (also see table 10).

Pumpage records for all these systems except that of Beverly Hills were collected by the Geological Survey from officials of the water

departments or from the city engineers. In some cases these records were extended to earlier years by utilizing estimates made by other agencies, chiefly the Metropolitan Water District (Vail, 1942, table 2). Records of pumpage by the city of Beverly Hills were obtained through the California Division of Water Resources. Available records of the yearly pumpage by each of the eight cities are given in table 7. In this table each record is carried back as far as available data will permit. Except as noted, records are for the calendar year. Total yearly withdrawals from the municipal and county water works district fields within the Torrance-Inglewood subarea from 1931 through 1945 are summarized in table 8, column 2.

TABLE 7.—Yearly withdrawal of ground water by municipalities in the Torrance-Santa Monica area

| Year                                                                                                                                                                | Acre-feet           | Year      | Acre-feet | Year      | Acre-feet           |
|---------------------------------------------------------------------------------------------------------------------------------------------------------------------|---------------------|-----------|-----------|-----------|---------------------|
| <b>Beverly Hills, 1929-45</b>                                                                                                                                       |                     |           |           |           |                     |
| [For year ending September 30; records obtained from California Division of Water Resources]                                                                        |                     |           |           |           |                     |
| 1929.....                                                                                                                                                           | <sup>1</sup> 4, 920 | 1935..... | 5, 654    | 1941..... | <sup>2</sup> 5, 874 |
| 1930.....                                                                                                                                                           | <sup>1</sup> 6, 900 | 1936..... | 6, 635    | 1942..... | <sup>3</sup> 4, 977 |
| 1931.....                                                                                                                                                           | <sup>1</sup> 6, 960 | 1937..... | 6, 778    | 1943..... | <sup>2</sup> 4, 703 |
| 1932.....                                                                                                                                                           | <sup>1</sup> 6, 290 | 1938..... | 6, 801    | 1944..... | <sup>2</sup> 5, 030 |
| 1933.....                                                                                                                                                           | <sup>1</sup> 6, 480 | 1939..... | 7, 958    | 1945..... | <sup>2</sup> 4, 824 |
| 1934.....                                                                                                                                                           | 6, 139              | 1940..... | 7, 742    |           |                     |
| <b>El Segundo, 1931-45</b>                                                                                                                                          |                     |           |           |           |                     |
| 1931.....                                                                                                                                                           | <sup>3</sup> 412    | 1936..... | 728       | 1941..... | 808                 |
| 1932.....                                                                                                                                                           | <sup>4</sup> 460    | 1937..... | 966       | 1942..... | 1, 027              |
| 1933.....                                                                                                                                                           | 502                 | 1938..... | 942       | 1943..... | 1, 098              |
| 1934.....                                                                                                                                                           | 697                 | 1939..... | 680       | 1944..... | 1, 269              |
| 1935.....                                                                                                                                                           | 706                 | 1940..... | 709       | 1945..... | 1, 156              |
| <b>Hawthorne, 1931-45</b>                                                                                                                                           |                     |           |           |           |                     |
| [Estimates by Metropolitan Water District through 1941; records from city engineer beginning in 1942]                                                               |                     |           |           |           |                     |
| 1931.....                                                                                                                                                           | 410                 | 1936..... | 690       | 1941..... | 1, 120              |
| 1932.....                                                                                                                                                           | 500                 | 1937..... | 700       | 1942..... | 1, 900              |
| 1933.....                                                                                                                                                           | 500                 | 1938..... | 800       | 1943..... | 1, 980              |
| 1934.....                                                                                                                                                           | 550                 | 1939..... | 850       | 1944..... | 2, 302              |
| 1935.....                                                                                                                                                           | 600                 | 1940..... | 900       | 1945..... | 1, 852              |
| <b>Inglewood, 1923-45</b>                                                                                                                                           |                     |           |           |           |                     |
| [Record for years 1923-28 from Los Angeles County Flood Control District; for years 1931-36 from Metropolitan Water District; for years 1937-45 from city engineer] |                     |           |           |           |                     |
| 1923.....                                                                                                                                                           | 870                 | 1931..... | 2, 170    | 1939..... | 3, 860              |
| 1924.....                                                                                                                                                           | 2, 280              | 1932..... | 2, 560    | 1940..... | 3, 610              |
| 1925.....                                                                                                                                                           | 1, 400              | 1933..... | 2, 440    | 1941..... | 3, 840              |
| 1926.....                                                                                                                                                           | 1, 320              | 1934..... | 2, 650    | 1942..... | 4, 190              |
| 1927.....                                                                                                                                                           | 2, 010              | 1935..... | 2, 350    | 1943..... | 4, 776              |
| 1928.....                                                                                                                                                           | 2, 240              | 1936..... | 2, 670    | 1944..... | 4, 939              |
| 1929.....                                                                                                                                                           |                     | 1937..... | 2, 810    | 1945..... | 5, 297              |
| 1930.....                                                                                                                                                           |                     | 1938..... | 3, 060    |           |                     |

<sup>1</sup> Metered consumption plus 10 percent to cover estimated losses.

<sup>2</sup> Additional water taken from Metropolitan Water District.

<sup>3</sup> Estimate by Metropolitan Water District.



102 GEOLOGY, HYDROLOGY, TORRANCE-SANTA MONICA AREA

TABLE 7.—Yearly withdrawal of ground water by municipalities in the Torrance-Santa Monica area—Continued

| Year                                                                                                     | Acro-feet           | Year      | Acro-feet           | Year      | Acro-feet           |
|----------------------------------------------------------------------------------------------------------|---------------------|-----------|---------------------|-----------|---------------------|
| <b>Los Angeles, 1918-45</b>                                                                              |                     |           |                     |           |                     |
| [Total withdrawal from Lomita and Wilmington pumping plants] <sup>4</sup>                                |                     |           |                     |           |                     |
| 1919.....                                                                                                | 4, 272              | 1928..... | 7, 892              | 1937..... | 0                   |
| 1920.....                                                                                                | 4, 561              | 1929..... | 9, 774              | 1938..... | 111                 |
| 1921.....                                                                                                | 5, 285              | 1930..... | 3, 207              | 1939..... | 48                  |
| 1922.....                                                                                                | 5, 937              | 1931..... | 8, 615              | 1940..... | 0                   |
| 1923.....                                                                                                | 7, 335              | 1932..... | 8, 073              | 1941..... | 105                 |
| 1924.....                                                                                                | 6, 950              | 1933..... | 8, 434              | 1942..... | 92                  |
| 1925.....                                                                                                | 6, 805              | 1934..... | 8, 000              | 1943..... | 651                 |
| 1926.....                                                                                                | 7, 023              | 1935..... | 7, 211              | 1944..... | 794                 |
| 1927.....                                                                                                | 7, 312              | 1936..... | 0                   | 1945..... | 2, 058              |
| <b>Manhattan Beach, 1931-45</b>                                                                          |                     |           |                     |           |                     |
| (Estimates by city engineer, based on rated capacity of booster pumps; rounded off by Geological Survey) |                     |           |                     |           |                     |
| 1931.....                                                                                                | 550                 | 1936..... | 650                 | 1941..... | 1, 000              |
| 1932.....                                                                                                | 550                 | 1937..... | 700                 | 1942..... | 1, 050              |
| 1933.....                                                                                                | 600                 | 1938..... | 750                 | 1943..... | 1, 300              |
| 1934.....                                                                                                | 600                 | 1939..... | 900                 | 1944..... | 1, 300              |
| 1935.....                                                                                                | 650                 | 1940..... | 950                 | 1945..... | 1, 300              |
| <b>Santa Monica, 1931-45</b>                                                                             |                     |           |                     |           |                     |
| 1931.....                                                                                                | <sup>5</sup> 2, 496 | 1936..... | 6, 790              | 1941..... | <sup>6</sup> 4, 469 |
| 1932.....                                                                                                | 4, 288              | 1937..... | 7, 147              | 1942..... | 238                 |
| 1933.....                                                                                                | 5, 117              | 1938..... | 7, 939              | 1943..... | 33                  |
| 1934.....                                                                                                | 5, 727              | 1939..... | 8, 525              | 1944..... | 38                  |
| 1935.....                                                                                                | 5, 812              | 1940..... | 8, 925              | 1945..... | 19                  |
| <b>Torrance, 1931-45</b>                                                                                 |                     |           |                     |           |                     |
| 1931.....                                                                                                | <sup>7</sup> 800    | 1936..... | <sup>7</sup> 1, 070 | 1941..... | 1, 178              |
| 1932.....                                                                                                | <sup>7</sup> 800    | 1937..... | 1, 115              | 1942..... | 1, 500              |
| 1933.....                                                                                                | <sup>7</sup> 760    | 1938..... | 1, 350              | 1943..... | 1, 757              |
| 1934.....                                                                                                | <sup>7</sup> 890    | 1939..... | 1, 328              | 1944..... | 1, 786              |
| 1935.....                                                                                                | <sup>7</sup> 875    | 1940..... | 1, 376              | 1945..... | 1, 743              |

<sup>4</sup> For withdrawal from all well fields of the city of Los Angeles within the coastal plain from 1918 through 1944, see Poland, J. F., Sinnott, Allen, and others (report on withdrawals of ground water from the Long Beach-Santa Ana area), table 4, p. 39.  
<sup>5</sup> Pumpage for April through December.  
<sup>6</sup> Water supply chiefly from Metropolitan Water District beginning in 1941.  
<sup>7</sup> Records from Metropolitan Water District.

**WITHDRAWAL FROM THE TORRANCE-INGLEWOOD SUBAREA, 1931-45**  
**METHODS OF EVALUATING WITHDRAWAL**

*Industrial consumption.*—In the southern and central parts of the Torrance-Inglewood subarea, south of El Segundo Boulevard, 20 industrial plants currently obtain their water from wells. The largest use is by petroleum refineries, of which eight are in this area. Most of the records of withdrawal of ground water by each of these industrial plants was obtained from plant representatives. Meter records were available for all plants using large quantities of water. However, estimates that were supplied for several of the smaller plants were based on well performance and hours of operation.

In the central part of the west basin, between El Segundo Boulevard and the Ballona escarpment, there are a number of industrial plants,

but, as far as known, all of these plants purchase their water from municipalities or water companies.

*Pumpage by large water companies.*—Within the Torrance-Inglewood subarea about 25 private water companies supply water for domestic, irrigation, and industrial uses. Meter records of production are available for several of the larger companies. In connection with its field canvass of wells, the Geological Survey collected meter records from the California Water Service Co., the Dominguez Water Corp., the Palos Verdes Water Co., the Palisades Del Rey Water Co., and the Southern California Water Co. In addition, the pumpage of the Moneta Water Co. has been interpolated from estimates by other agencies in 1931 and 1944. With the exception of the part of the withdrawal by the Dominguez Water Corp. that is sold to industrial plants, total draft by these six companies is given in table 8, column 4.

*Pumpage for irrigation and miscellaneous uses.*—Withdrawal of ground water by private irrigators and by many small water companies is substantial. However, neither meter records nor estimates are available for most of this use. In its appraisal of withdrawal in the Long Beach-Santa Ana area, the Geological Survey estimated pumpage for agricultural purposes by deriving yearly mean energy factors (energy expended in raising a unit quantity of water) and applying these factors to the quantity of electrical energy expended in pumping from wells. In appraising pumpage for irrigation from the west basin, however, it was found that this method was not readily applicable because: (1) three operating districts of the Southern California Edison Co. extend from the west basin into the main coastal basin, (2) pump-efficiency tests were not sufficiently comprehensive in distribution to define satisfactory yearly energy factors, and (3) many of the smaller water companies are not supplied with energy under the agricultural-rate schedule of the Edison Co.

Because the energy-factor method could not be readily applied, the pumpage for irrigation and for miscellaneous uses in the Torrance-Inglewood subarea was estimated from figures of irrigated acreage, considered together with a plot of electrical energy purchased yearly on the agricultural-rate schedule. Specifically, in 1932 and in 1941, the California Division of Water Resources made crop surveys of the lands in the west basin. Unpublished data in the files of the Division, compiled from these surveys and from maps showing service areas of municipal systems and public utilities, have been utilized by the Geological Survey to estimate the acreage supplied from wells with meter record estimate of pumpage. For the Torrance-Inglewood subarea, it has been estimated from these data that in 1932 an area of about 13,200 acres was so supplied (about 90 percent classified by the Division as irrigated lands and about 10 percent classified as

domestic and industrial areas). Water use on the 13,200 acres in 1932, a year of nearly average rainfall (table 2), is estimated to have been about 13,200 acre-feet, an average use of 1 acre-foot per acre. This figure agrees with estimates made by the Los Angeles County Flood Control District from a field survey in 1931 (Dockweiler, 1932, pl. 11), which indicated that private irrigation and miscellaneous plants in the part of the Torrance-Inglewood subarea west of Vermont Avenue pumped about 9,200 acre-feet in that year. That figure did not include withdrawal from similar plants east of Vermont Avenue, but it is estimated that these plants pumped about 4,000 acre-feet in 1932.

Furthermore, from the crop survey of the California Division of Water Resources made in 1941, it has been estimated that the lands in the Torrance-Inglewood subarea supplied with water from wells for which neither meter records nor estimates are available was about 16,000 acres in that year. About three-quarters of this area—or about the same acreage as in 1932—was classified by the Division as irrigated lands and about one-quarter of the area was classified as domestic and industrial sections. Thus, it is apparent that an increase of about 3,000 acres in lands used for domestic and industrial development supplied with water by noncanvassed withdrawals had occurred since 1932. Data are not available to indicate the rate at which this increase in domestic use took place. Therefore, it is assumed to have been uniform, or about 330 acres per year, and to have required a duty of 1 acre-foot per acre.

To obtain yearly figures for the unmetered irrigation and domestic uses through 1941, it has been assumed that the annual sales of electrical energy under the agricultural-rate classification in the Redondo and Inglewood operating districts of the Southern California Edison Co. furnish an approximate index of water pumped for agricultural use from 1931 through 1941. In that 11-year period the average decline of water level within the Torrance-Inglewood subarea was about 4 feet for the Silverado water-bearing zone, the principal aquifer. The small increase in lift may have been more than offset by improvement in pumping-plant efficiencies. The year 1932, with an estimated withdrawal of 13,200 acre-feet for unmetered agricultural and domestic uses, has been taken as the base year. Thus, for 1931 and the years 1933 through 1941, estimates of withdrawal for unmetered irrigation use in each year have been obtained by multiplying 13,200 by the percentage of electrical energy used in that year in comparison to the 1932 base use. To the figure so obtained has been added the estimated increase in uncanvassed domestic use, prorated as described above. The sum of these two elements has been entered in table 8, column 6.

For the war years 1942-45, agricultural withdrawals decreased substantially but domestic expansion was greatly accelerated, and a considerable part of this increased domestic use of water was met by the smaller water companies. Data are not available to indicate the proportionate changes in area. Therefore, water used for irrigation and for miscellaneous purposes in these 4 years is assumed to have been constant at about 13,000 acre-feet per year.

The estimates entered in table 8 for yearly withdrawals by private irrigators and for miscellaneous use are only approximate. However, these figures constitute less than one-quarter of the total pumpage from the Torrance-Inglewood subarea. Extensive work would have been required to derive a more accurate estimate. In 1948 the California Division of Water Resources began a detailed study of the quantity of ground water drawn from each of the wells or well fields of this subarea, in connection with the pending adjudication of water rights. Accordingly, duplication of work, which the Division must carry out for legal reasons, was not believed to be warranted.

#### ESTIMATE OF TOTAL PUMPAGE

Table 8 and figure 3 summarize the yearly withdrawal from the Torrance-Inglewood subarea for the 15 years from 1931 through 1945. The estimated over-all draft from this area decreased from 52,600 acre-feet in 1931 to 44,500 acre-feet in 1937, rose to 52,700 acre-feet in 1942, and then increased sharply during the war years to about 78,000 acre-feet in 1945. As shown by the table, most of this expansion was caused by increased industrial demand. Withdrawals for

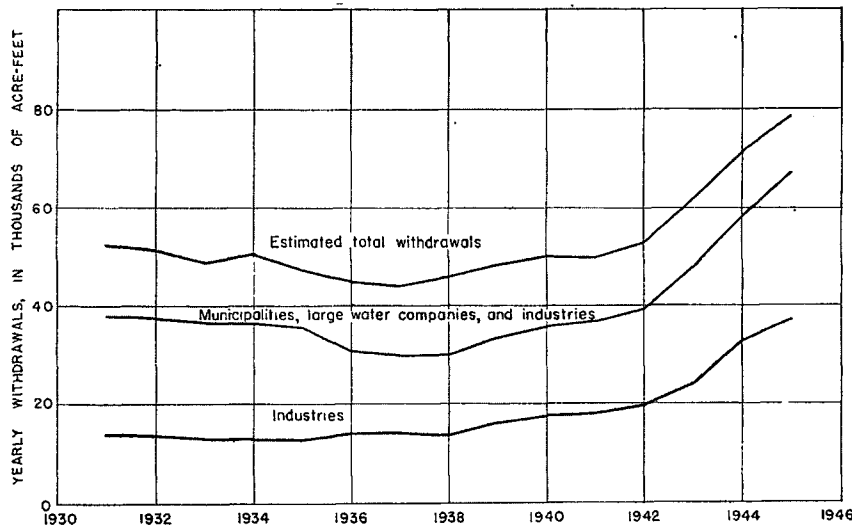

FIGURE 3.—Estimated withdrawals of ground water from the Torrance-Inglewood subarea, 1931-45.

106 GEOLOGY, HYDROLOGY, TORRANCE-SANTA MONICA AREA

industrial use were nearly constant at 14,000 acre-feet per year from 1931 through 1938, or about 30 percent of the total use; and increased to 19,640 acre-feet in 1942; and to 37,420 acre-feet in 1945, or about 48 percent of the total use. Most of the increase in industrial use of water during the war years was due to the expanded requirements of the oil refineries; in 1945, these refineries accounted for about 88 percent of the industrial demand.

TABLE 8.—Estimated yearly withdrawal of ground water from the Torrance-Inglewood subarea,<sup>1</sup> in acre-feet, 1931-45

| Year      | Municipal systems <sup>2</sup> | Industries <sup>3</sup> | Large water companies | Subtotal | Irrigation and miscellaneous | Total <sup>4</sup> |
|-----------|--------------------------------|-------------------------|-----------------------|----------|------------------------------|--------------------|
| 1931..... | 12,720                         | 14,720                  | 11,210                | 38,650   | 13,900                       | 52,600             |
| 1932..... | 12,460                         | 14,710                  | 10,690                | 37,860   | 13,200                       | 51,100             |
| 1933..... | 12,900                         | 13,100                  | 10,200                | 36,200   | 13,000                       | 49,200             |
| 1934..... | 12,830                         | 13,340                  | 10,230                | 36,400   | 14,400                       | 50,800             |
| 1935..... | 12,030                         | 13,510                  | 10,250                | 35,790   | 12,100                       | 47,900             |
| 1936..... | 5,300                          | 14,520                  | 10,940                | 30,760   | 14,600                       | 45,400             |
| 1937..... | 5,580                          | 14,830                  | 9,830                 | 30,240   | 14,300                       | 44,500             |
| 1938..... | 6,250                          | 13,670                  | 10,250                | 30,170   | 16,000                       | 46,200             |
| 1939..... | 6,020                          | 16,470                  | 11,220                | 33,710   | 14,900                       | 48,600             |
| 1940..... | 6,670                          | 17,380                  | 11,280                | 35,330   | 15,200                       | 50,500             |
| 1941..... | 7,010                          | 18,520                  | 11,200                | 36,730   | 13,600                       | 50,300             |
| 1942..... | 8,660                          | 19,640                  | 11,360                | 39,660   | * 13,000                     | 52,700             |
| 1943..... | 10,640                         | 24,740                  | 12,770                | 48,150   | * 13,000                     | 61,200             |
| 1944..... | 12,000                         | 33,680                  | 13,020                | 58,700   | * 13,000                     | 71,700             |
| 1945..... | 13,220                         | 37,420                  | 14,770                | 65,410   | * 13,000                     | 78,400             |

<sup>1</sup> For purposes of this report, the part of the west basin south of the Ballona escarpment is called the Torrance-Inglewood subarea.

<sup>2</sup> Includes water pumped by County Water Works Districts 13 and 22.

<sup>3</sup> Includes water sold to industrial plants by the Dominguez Water Corp.

<sup>4</sup> Rounded off to three figures.

\* Flat estimate only.

The municipal systems accounted for nearly 25 percent of the total draft in 1931 and about 17 percent in 1945. The decrease in use by municipal systems from about 12,000 acre-feet in 1935 to 5,300 acre-feet in 1936 was a result of cessation of withdrawal at the Lomita and Wilmington well fields of the city of Los Angeles, these fields had withdrawn about 8,000 acre-feet per year in the early thirties. Since 1936 the yield from these two well fields has been small.

WITHDRAWAL FROM THE CULVER CITY SUBAREA

Withdrawal of ground water from the Culver City subarea (the part of the west basin north of the Ballona escarpment) has not been appraised in detail. The field canvass of wells was carried only from 1 to 2 miles north of Ballona Gap and collection of records of pumpage from privately owned wells was not attempted for any part of the

Culver City subarea. However, the most heavily pumped well fields have been those of the city of Santa Monica and those of the Southern California Water Co. Table 9 gives the draft from the Culver City subarea by these two agencies yearly from 1931 through 1945.

TABLE 9.—*Withdrawal of ground water, in acre-feet, from the Culver City subarea by the city of Santa Monica and by the Southern California Water Co., 1931-45*

[Sum of pumpage from the Marine, Charnock, and Arcadia plants of the city of Santa Monica, and from the Pacific, Charnock, Sepulveda, and Manning plants of the Southern California Water Co.]

| Year      | Acre-feet | Year      | Acre-feet | Year      | Acre-feet |
|-----------|-----------|-----------|-----------|-----------|-----------|
| 1931..... | 7, 111    | 1936..... | 10, 461   | 1941..... | 8, 705    |
| 1932..... | 8, 066    | 1937..... | 10, 956   | 1942..... | 4, 405    |
| 1933..... | 8, 607    | 1938..... | 11, 773   | 1943..... | 5, 622    |
| 1934..... | 9, 238    | 1939..... | 12, 567   | 1944..... | 6, 125    |
| 1935..... | 9, 312    | 1940..... | 12, 933   | 1945..... | 6, 106    |

In addition to the withdrawal from the principal well fields, shown in table 9, water from private plants was used to irrigate about 3,300 acres of land in 1932 and about 3,000 acres in 1941 (unpublished data from California Division of Water Resources), chiefly along the south edge of Ballona Gap and in secs. 2 and 3, T. 2. S., R. 15 W. (pl. 2). These irrigated areas were supplied almost exclusively from private wells, although possibly as much as 200 acres of this land have been irrigated with water pumped directly from Ballona Creek (C. E. Bollinger, Los Angeles County Flood Control District, oral communication). About two-thirds of the over-all acreage is planted in garden and field crops and one-third is in irrigated grass. The quantity of ground water pumped to irrigate these lands probably is about 4,000 acre-feet a year.

The privately owned wells yielding water for irrigation in the Culver City subarea in 1945 (excluding the area north of the north boundary of T. 2 S.) were distributed as follows: in the coastal area, 30 wells; in the Charnock subbasin, 24 wells; in the crestal subbasin, 2 wells. If the annual well yields are assumed to be proportional to the distribution, the estimated draft for irrigation (4,000 acre-feet) would be about 2,100 acre-feet from the coastal area, 1,700 acre-feet from the Charnock subarea, and 200 acre-feet from the crestal subbasin. Actually, because yields of wells in the Charnock subbasin are larger than those of wells nearer the coast and because slightly more than half of the irrigated acreage is supplied by water pumped from the Charnock subbasin, it is inferred that the division of draft as of 1945 was about 1,800 acre-feet from the coastal area, 2,000 acre-feet from the Charnock subbasin, and 200 acre-feet from the crestal subbasin.

The larger part of the withdrawal from the Charnock subbasin has been for public supply and has been obtained from the Charnock

well field of the city of Santa Monica and the Charnock well field of the Southern California Water Co.; both fields are in the NW $\frac{1}{4}$  sec. 11, T. 2 S., R. 15 W. (pl. 2). The yearly withdrawal records from these two well fields for the 15 years are graphed on plate 14. The Sepulveda plant of the Southern California Water Co. (well 2/15-11J) also is in this subbasin. The over-all draft from the Charnock subbasin from these three well fields, and from the private irrigation wells previously discussed, is estimated to have been approximately 9,000 acre-feet in 1931, 10,000 acre-feet in 1935, 12,500 acre-feet in 1940 (the peak year), and 7,000 acre-feet in 1945.

In the crestal subbasin, perennial draft has been chiefly by: (1) the Manning plant of the Southern California Water Co. from well 2/15-1C, beginning in the middle twenties; (2) the Metro-Goldwyn-Mayer Corp., from wells 2/15-12B1 and 2/14-7P1, beginning in 1932; (3) the LAC Chemical Co., from well 2/14-6H1, beginning in 1942; and (4) the Holy Cross Cemetery from well 2/14-18Q1, and irrigation wells 2/14-18F1 and F2. The over-all draft from this subbasin did not exceed a few hundred acre-feet per year until the middle thirties; it was about 1,100 acre-feet in 1935 and in 1940, and had increased to about 1,600 acre-feet in 1945.

For the Culver City subarea as a whole, it is estimated that the withdrawal in 1931 was about 13,000 acre-feet. Withdrawal increased to about 20,000 acre-feet in 1940, the peak year of pumpage by the city of Santa Monica. In that year withdrawal was approximately two-fifths as large as it was in the Torrance-Inglewood subarea to the south. In 1945, when draft by the city of Santa Monica had ceased, the withdrawal had decreased to about 12,000 acre-feet per year, or only about one-sixth of that in the Torrance-Inglewood subarea. The over-all use of water in the Culver City subarea is many times greater than the ground-water draft. Current importations (1948) consist chiefly of surface water from the Los Angeles municipal supply, the Colorado River and ground water from the Sentney plant of the Southern California Water Co.

#### WITHDRAWAL INLAND FROM THE WEST BASIN

About 90 square miles of the Torrance-Santa Monica area is inland from the west basin and almost entirely within the main coastal basin. The over-all withdrawal of ground water from the 90 square miles was not evaluated in this investigation.

Except for the area within the city of Beverly Hills, nearly all of the territory north of Imperial Highway is within the city of Los Angeles and is supplied chiefly by water from the Los Angeles municipal system. Most of the Los Angeles municipal supply to the coastal

plain is imported from the Owens Valley or from the San Fernando Valley, but in this inland area the city currently obtains a minor auxiliary supply of ground water from its Manhattan and 99th Street plants. Some of the area north of Imperial Highway is served by the Sentney, South Los Angeles, and Normandie systems of the Southern California Water Co. The distribution and magnitude of draft from the larger well fields for public supply, as of 1945, are shown on plate 12.

Inland from the west basin, the position and slope of the pressure level are critical with respect to the rate of replenishment by underflow across the west basin boundary. Both the position and slope of the pressure level between Slauson and Rosecrans Avenues are believed to be affected to a major extent by the very heavy withdrawal in the Huntington Park area, a short distance to the east of the east boundary of the Torrance-Santa Monica area. However, the position and slope of the pressure level are affected also by the intensity of local withdrawal. Thus, it is of interest to note that the combined withdrawal from the pumping plants of the city of Los Angeles and of the Southern California Water Co., between Slauson and Rosecrans Avenues, was 4,030 acre-feet in 1931, 3,130 acre-feet in 1938, and 6,440 acre-feet in 1945.

#### DISTRIBUTION OF DRAFT AS OF 1945

By 1945 most of the withdrawal of ground water from the Torrance-Santa Monica area was concentrated at a number of intensively pumped well fields operated almost entirely for public supply or industrial use. To show the nature of this concentration and its effect on the water levels in the Silverado water-bearing zone and in the correlative aquifers within the San Pedro formation beyond the extent of the Silverado, the magnitude of draft at such plants within the coastal zone of the Torrance-Santa Monica area has been indicated on plate 12 by means of circles whose areas are proportional to the draft. The centers of these circles are plotted at the centers of pumping. For closely grouped wells, the circle commonly encompasses the entire well field; for groups of widely scattered wells which supply a single system, such as the South Los Angeles system of the Southern California Water Co., the circle is plotted approximately at the geographic center of pumping. The circles so plotted on plate 12 are numbered and table 10 identifies the agency withdrawing the water; numbers in this table correspond with those of the plate.

As shown on plate 12, the area of most intensive draft in 1945 was between Dominguez Hill and State Street, approximately along Alameda Street.



110 GEOLOGY, HYDROLOGY, TORRANCE-SANTA MONICA AREA

TABLE 10.—Agencies withdrawing ground water from the coastal zone of the Torrance-Santa Monica area in 1945 for public supply or industrial use

[Numbers identify location and magnitude of draft as indicated on plate 12; well fields withdrawing less than 200 acre-feet not listed]

| Number on plate 12 | Agency                          | Number on plate 12 | Agency                          |
|--------------------|---------------------------------|--------------------|---------------------------------|
| 1.....             | City of Beverly Hills.          | 11.....            | General Chemical Co.            |
| 2a.....            | Southern California Water Co.:  | 12.....            | City of Manhattan Beach.        |
|                    | Sentney plant.                  | 13a.....           | } California Water Service Co.  |
| 2b.....            | Manning plant.                  | 13b.....           |                                 |
| 2c.....            | Charnock plant.                 | 14a.....           | Dominguez Water Corp.:          |
| 2d.....            | Sapulveda plant.                |                    | Redondo plant.                  |
| 2e.....            | Pacific plant.                  | 14b.....           | Main plant.                     |
| 2½.....            | Metro-Goldwyn-Mayer Corp.       | 15.....            | General Petroleum Corp.         |
| 3a.....            | City of Inglewood:              | 16.....            | Moneta Water Co.                |
|                    | Plants in main basin.           | 17.....            | City of Torrance.               |
| 3b.....            | } Plants in west basin.         | 18.....            | Columbia Steel Co.              |
| 3c.....            |                                 |                    | 19.....                         |
| 4a.....            | City of Los Angeles:            | 20.....            | County Water Works District 13. |
|                    | Manhattan plant.                | 21.....            | Palos Verdes Water Co.          |
| 4b.....            | 99th Street plant.              | 22.....            | City of Los Angeles:            |
| 5a.....            | Southern California Water Co.:  |                    | Lomita plant.                   |
|                    | South Los Angeles system.       | 23.....            | Union Oil Co.                   |
| 5b.....            | Normandie system.               | 24.....            | The Texas Co.                   |
| 6a.....            | Lennox system.                  | 25a.....           | Shell Oil Co., Inc.:            |
| 6b.....            | Gardena system.                 |                    | Wilmington plant.               |
| 6c.....            | Lawndale system.                | 25b.....           | Dominguez plant.                |
| 7.....             | City of Hawthorne.              | 26.....            | Richfield Oil Corp.             |
| 8.....             | Airways Water Co.               | 27.....            | Tidewater Associated Oil Co.    |
| 9.....             | City of El Segundo.             | 28.....            | Johns-Manville Products Corp.   |
| 10.....            | Standard Oil Co. of California. | 29.....            | Stauffer Chemical Co.           |

PRINCIPAL SOURCES OF GROUND WATER

SOURCES IN THE TORRANCE-INGLEWOOD SUBAREA

In the Torrance-Inglewood subarea, the principal sources of the ground water, in order of increasing age, are: (1) the Gaspur water-bearing zone in the deposits of Recent age (in Dominguez Gap); (2) the "200-foot sand" in the unnamed upper Pleistocene deposits; (3) the "400-foot gravel" in the upper part of the San Pedro formation of Pleistocene age; and (4) the Silverado water-bearing zone in the middle and lower parts of the San Pedro formation. In relation to draft, the Silverado water-bearing zone is of primary importance, and the "200-foot sand," the "400-foot gravel," and the Gaspur water-bearing zone are of secondary importance, and probably in the order listed.

In 1945, the Silverado water-bearing zone was the source of water for: (1) all withdrawals by industries, with the exception of one small plant; (2) essentially all withdrawals from the municipal well fields of Hawthorne, El Segundo, Manhattan Beach, and Torrance, and about one-third of the withdrawal from the well fields of the city of Inglewood within the west basin; (3) all withdrawals by County Water Works Districts 13 and 22; (4) all withdrawals by the California Water Service Co., the Dominguez Water Corp., and the Palos Verdes Water Co., and about 90 percent of the withdrawal by the Lennox, Lawndale, and Gardena systems of the Southern California Water Co.; and (5) at least half of the withdrawals by private irrigators and the

smaller water companies. Of the total withdrawal from the Torrance-Inglewood subarea in 1945—approximately 78,000 acre-feet—about 68,000 acre-feet or 87 percent was taken from the Silverado water-bearing zone.

Of the remaining 13 percent—approximately 10,000 acre-feet—about 8 percent was drawn from the “200-foot sand” and associated aquifers in the unnamed upper Pleistocene deposits, about 3 percent from the “400-foot gravel,” and about 2 percent from the Gaspar water-bearing zone in Dominguez Gap.

#### SOURCES IN THE CULVER CITY SUBAREA

In the Culver City subarea the two principal sources of ground water, in order of increasing age, are (1) the “50-foot gravel” in the deposits of Recent age (in Ballona Gap); and (2) the main water-bearing zone of the San Pedro formation of Pleistocene age—believed to be the essential correlative of the Silverado water-bearing zone to the south. The main water-bearing zone of the San Pedro formation underlies all of Ballona Gap within the west basin and, at least in the Charnock subbasin, extends northward nearly 2 miles beyond the north edge of the Gap, or about to Pico Boulevard. No uniform water-bearing zone seems to exist north of Pico Boulevard. As shown by well logs, the aquifers are thin and discontinuous; as might be expected for alluvial deposits laid down by streams transporting debris from the Santa Monica Mountains.

The main water-bearing zone in the San Pedro formation has been the source of supply for: (1) almost all of the water pumped from the three well fields of the city of Santa Monica; (2) all of the withdrawal from the four well fields of the Southern California Water Co.; (3) nearly all of the withdrawal used for irrigation in the area north of Washington Boulevard, south of Pico Boulevard, and east of Centinela Avenue (pl. 2); and probably more than half of the water pumped for irrigation along the south side of the Ballona Gap. Thus, of the total withdrawal in the Culver City subarea in 1945—some 12,000 acre-feet—it is estimated that about 90 percent was drawn from the main water-bearing zone and associated aquifers within the San Pedro formation; most of the remaining 10 percent was drawn from the “50-foot gravel” in the deposits of Recent age in Ballona Gap.

#### SOURCES INLAND FROM THE WEST BASIN

As explained on page 108, the withdrawal from the 90 square miles of the Torrance-Santa Monica area inland from the west basin was not evaluated as a whole. However, all of the larger pumping plants draw water almost entirely from deposits of Pleistocene age and from aquifers within the San Pedro formation. These same

aquifers supply a substantial part of the replenishment to the west basin across the crest of the Newport-Inglewood uplift.

#### WATER-LEVEL FLUCTUATIONS

##### SCOPE AND UTILITY OF THE RECORDS

In 1903-4 Mendenhall made single measurements of depth to water or of artesian pressure head in several thousand wells on the coastal plain. To extend these data, water-level measurements were made in 41 representative wells at irregular intervals during the next two decades by the Geological Survey. Twenty-six of these wells were within the coastal and inland zones of the present investigation. The records through 1920 have been published by the Geological Survey (Ebert, 1921, p. 13-29); records for three wells for the years 1921-26 have been published by the California Division of Water Resources (Gleason, 1932, p. 62, 77, 104).

In connection with its investigation of water resources of the San Gabriel Valley, the Division of Water Rights in the California Department of Public Works, in cooperation with Los Angeles County and the city of Pasadena, measured depths to ground water periodically from 1923 until 1928 (Conkling, 1927, 1929, p. 171-200). This program superseded the earlier program of the Geological Survey but included only a few wells in the Torrance-Santa Monica area, all of which were in the territory east of Main Street—that is, in the vicinity of Compton and of Dominguez Gap.

The program of water-level measurements by the California Division of Water Rights was accompanied or followed by continuing programs of several agencies, which together extended over all the area of the present cooperative investigation. The two principal programs of periodic water-level measurement in the Torrance-Santa Monica area have been that of the Los Angeles Department of Water and Power, beginning in 1923 and terminating in 1941; and that of the Los Angeles County Flood Control District, beginning in 1928 and continuing to date. These programs have been supplemented by those of many other agencies, especially the following: The San Gabriel Valley Protective Association, beginning in 1928; the city of Pasadena, from 1928 to 1933; the city of Long Beach, beginning in 1929; the city of Beverly Hills, beginning in 1930; the Southern California Water Co., beginning about in 1929; and the California Water Service Co., beginning about in 1933. Periodic measurements have also been made by several other municipalities and water companies, by several industrial plants, and by a few individuals.

Nearly all the water-level records by the agencies listed above have been deposited with the Division of Water Resources in the Cali-

ifornia Department of Public Works and are available to the public. Representative records from selected observation wells have been published (Gleason, 1932).

Beginning in 1943, single measurements of depth to water were made by the Geological Survey in several scores of wells in connection with the field canvass of water wells in the Torrance-Santa Monica area. Measurements were continued semiannually until December 1945 in about 60 of these wells. Measurements were made at weekly or biweekly intervals from 1944 to November 1946 in 20 other wells. Water-level recorders were also operated on six wells for periods of a month to 2 years. All the periodic water-level measurements made by the Geological Survey have been published in water-supply papers (see p. 89). Table 11 shows the scope of water-level data available from all agencies, including data taken by the Geological Survey for the coastal zone of the Torrance-Santa Monica area.

TABLE 11.—*Scope of water-level records available from wells in the coastal zone of the Torrance-Santa Monica area, as of July 1946*

| Type of record                                  | Number of wells measured |              |               |
|-------------------------------------------------|--------------------------|--------------|---------------|
|                                                 | Active                   | Discontinued | Total         |
| Nonperiodic and miscellaneous measurements..... |                          |              | 266           |
| Semiannual measurements.....                    | 111                      | 140          | 251           |
| Monthly measurements.....                       | 125                      | 350          | 475           |
| Weekly measurements.....                        | 16                       | 4            | 20            |
| Water-level recorder operated.....              | 4                        | 27           | 31            |
| <b>Total.....</b>                               | <b>256</b>               | <b>521</b>   | <b>1, 043</b> |

These records of depth to water in wells are of inestimable value for the interpretation of the past and present hydrologic conditions, and they reveal the changes in pressure level or water table that have developed as a result of increasing draft. Hydrographs plotted from periodic measurements in single wells show the nature of fluctuations and changes in head within the tapped aquifers. Thus, hydrographs for wells tapping separate aquifers at one place reveal the degree or the lack of hydraulic continuity between those aquifers. Water-level contour maps drawn from data for one or more aquifers known to be hydraulically continuous present the water-level conditions at selected times; discontinuities in the water-level contours define basin boundaries or barrier features. Also, the regional changes in water level shown by comparing maps for separate times can be utilized to obtain estimates of change in storage if the specific yield or storage coefficient is known.

Hydrographs for wells in the Torrance-Santa Monica area show several types of fluctuations, related chiefly to recharge and discharge. Specifically these fluctuations are caused by: (1) recharge from streams, (2) recharge by penetration of rainfall, (3) recharge by underflow, (4) discharge by pumping, and (5) tidal oscillations. Typical fluctuations are illustrated and discussed in following pages.

The water-level contour maps previously introduced (pls. 9-12) show four positions of the water level and directions of water movement in the aquifers of principal draft between 1904 and 1945. Hydrographs for 59 selected wells in the Torrance-Santa Monica area are presented on figures 4 and 5 and plates 13 and 14. The locations of the wells are shown on plate 11; the tapped zones are identified on the individual hydrographs and by symbols on plate 11. Pertinent hydrologic data are given in table 12.

#### FLUCTUATIONS IN THE TORRANCE-INGLEWOOD SUBAREA

Selected hydrographs assembled on figures 4 and 5 and plates 13 and 14, illustrate the rate of change in pressure head in the several aquifers in the Torrance-Inglewood subarea. Most of the hydrographs concern wells that tap the Silverado water-bearing zone, which supplied about 87 percent of the draft in 1945. Other hydrographs are presented, however, to compare pressure heads in overlying aquifers with that in the Silverado water-bearing zone. These paired hydrographs are of particular interest for three reasons: (1) they furnish proof that the aquifers have substantial hydraulic separation; (2) they indicate the effect of and furnish a clue to the magnitude of draft from each of the aquifers; and (3) they show the differentials in pressure head that have been developed between the several aquifers in the period of most intensive use and are of considerable interest in connection with possible downward migration of contamination, either now or in the future, and with the feasibility of artificial recharge.

#### DIFFERENCE IN HEAD DEVELOPED BETWEEN THE SEVERAL AQUIFERS

##### VICINITY OF DOMINGUEZ GAP

The Gaspur water-bearing zone of Recent age in Dominguez Gap occurs from about 60 to 140 feet below the land surface and is separated from the underlying Silverado water-bearing zone of Pleistocene age by several hundred feet of silt and fine sand of low permeability (pl. 6). On figure 5C, the composite hydrograph for wells 4/13-14K1 and 4/13-14L1 represents the pressure level in the Gaspur water-bearing zone from 1924 through 1946, and the hydrograph for wells 4/13-21H3 and 4/13-23G2 represents the pressure head in the Silverado water-bearing zone for the same period. Data from the Mendenhall well canvass of 1904 indicate that pressure levels in the two

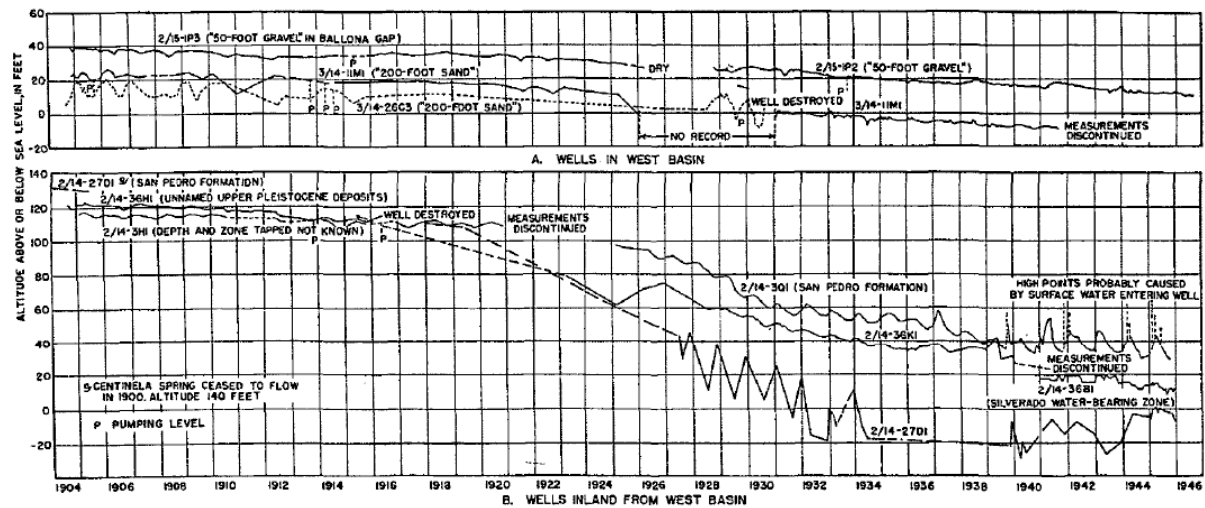

FIGURE 4.—Hydrographs of longest record for wells in and near the west basin.

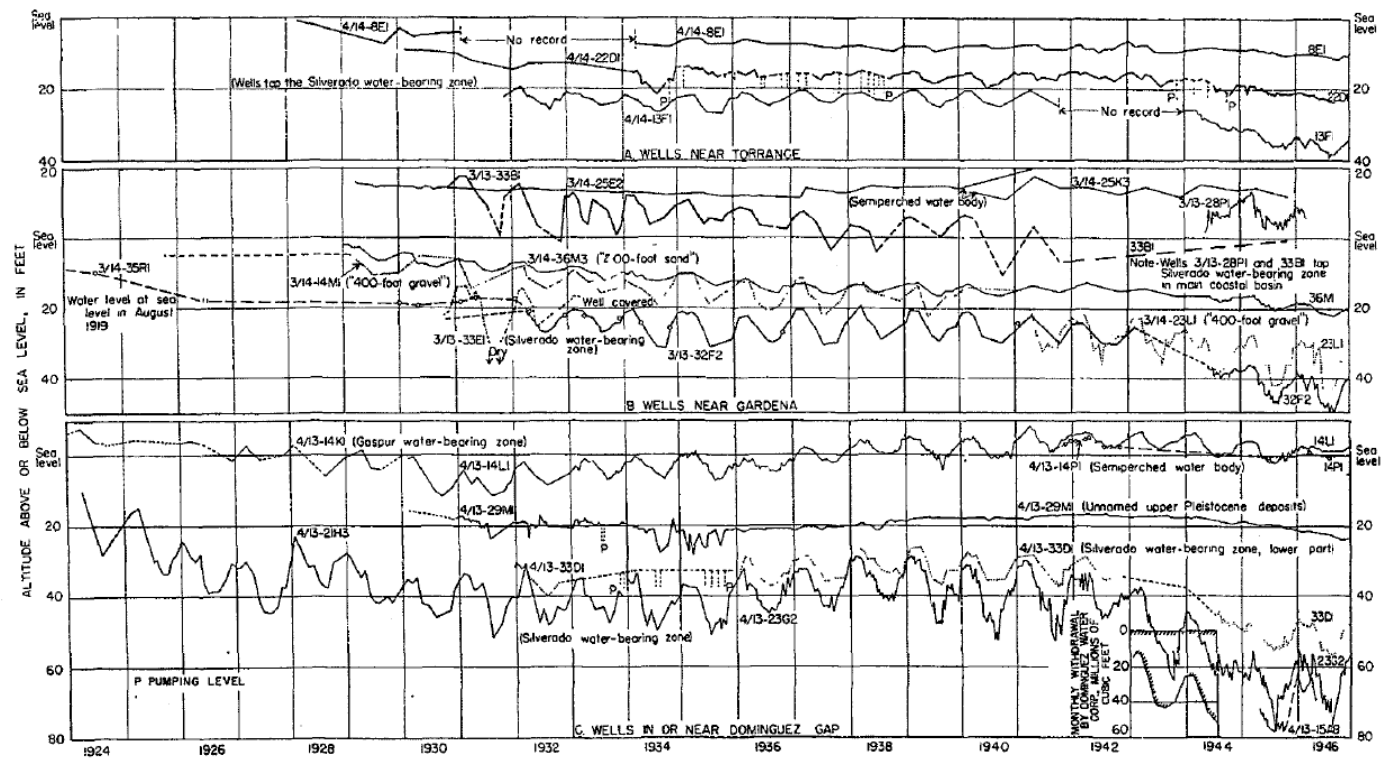

FIGURE 5.—Hydrographs for selected wells in the southern part of the west basin.

TABLE 12.—Wells in or near the west basin for which hydrographs are plotted on figures 4 and 5 and plates 13 and 14

| Well        |                       | Owner's name and well                                            | Water-yielding zone or zones |                         |                                     | Agency supplying principal record <sup>3</sup> |
|-------------|-----------------------|------------------------------------------------------------------|------------------------------|-------------------------|-------------------------------------|------------------------------------------------|
| USGS        | Location <sup>1</sup> |                                                                  | Depth <sup>2</sup> (feet)    | Feet below land surface | Stratigraphic correlation           |                                                |
| 2/14-3H1    |                       | Artesian Land and Water Co.                                      |                              |                         | (?)                                 | USGS                                           |
| 3Q1         | 2667                  | City of Los Angeles.<br>Southern California Water Co.:           | 661                          |                         | San Pedro formation.                | LADWP,<br>LACFCD.                              |
| 5D5         | 2626D                 | Sentney plant, well 5.                                           | 266                          | 152-257                 | do.                                 | SCWC                                           |
| 5D9         |                       | Sentney plant, well 9.                                           | 54                           | 23-54                   | "50-foot gravel"                    | SCWC                                           |
| 5F2         | 2627                  | Shell Oil Co., Inc.                                              | 240                          |                         | San Pedro formation.                | LADWP                                          |
| 7M1         | 2609A                 | Mrs. J. D. Machado.                                              | 500                          |                         | do.                                 | LADWP                                          |
| 18F1        | 2619A                 | Lewis A. Crank                                                   | 265.8                        | 90-312                  | do.                                 | LADWP,<br>LACFCD                               |
| 27D1        | 1352                  | City of Inglewood, well 7.                                       | 300                          | 135-286                 | do.                                 | LACFCD, USGS                                   |
| 27F1, 2, 3. | 1363                  | Inglewood Park Cemetery Assn., wells 7, 2, 11.                   |                              |                         | Silverado zone.                     | LADWP, USGS                                    |
| 32C1        | 1324                  | Formerly by Bowler.                                              | 190                          |                         | "200-foot sand"                     | LADWP,<br>LACFCD                               |
| 34C1        | 1364                  | Inglewood Country Club.                                          | 450                          | 264-362                 | Silverado zone.                     | LADWP                                          |
| 36B1        | 1404                  | Southern California Water Co., Manchester Heights plant, well 1. | 320                          |                         | do.                                 | SCWC                                           |
| 36E1        |                       | Formerly by Mrs. Bedell.                                         | 110                          |                         | Unnamed upper Pleistocene deposits. | USGS                                           |
| 36K1        | 1404B                 | Olivita Mutual Water Co.                                         | 565                          |                         | Silverado zone.                     | LADWP                                          |
| 2/15-1P2    | 2598                  | Guy Beringhely                                                   | { 80<br>185 }                |                         | "50-foot gravel"                    | { LACFCD,<br>LADWP }                           |
| 1P3         | 2597B                 | Formerly by Borjorquez.<br>Southern California Water Co.:        | 86                           |                         | do.                                 | USGS                                           |
| 11E3        | 2578P                 | Charnock plant, well 1.                                          | 405                          | 196-376                 | San Pedro formation.                | SCWC                                           |
| 11F4        | 2578C                 | Charnock plant well 4.                                           | 380                          | 168-346                 | do.                                 | SCWC                                           |
| 16F1        | 1240                  | J. H. Evans                                                      | 56.0                         |                         | "50-foot gravel"                    | LACFCD,<br>LADWP                               |
| 22B4        | 1261A                 | Clarence Michel                                                  | 207                          | 63-205                  | San Pedro formation.                | LACFCD,<br>LADWP                               |
| 23F1        | 1271M                 | Los Angeles County Flood Control District, test hole 1.          | 24                           |                         | Semiperched water body.             | LACFCD                                         |
| 24C1        | 1291                  | Mesmer City Corp., Ltd.                                          | 402                          | 170-395                 | San Pedro formation.                | LADWP                                          |
| 34H1        | 1264C                 | Formerly by Barnard.                                             | 250                          | 130-250                 | do.                                 | LADWP,<br>LACFCD                               |
| 34K1        | 1264                  | Palisades del Rey Water Co., well 1.                             | 208                          | 91-133                  | do.                                 | LADWP, owner.                                  |

See footnotes at end of table, p. 119.



118 GEOLOGY, HYDROLOGY, TORRANCE-SANTA MONICA AREA

TABLE 12.—Wells in or near the west basin for which hydrographs are plotted on figures 4 and 5 and plates 13 and 14—Continued

| Well      |                       | Owner's name and well                                        | Water-yielding zone or zones |                         |                                     | Agency supplying principal record <sup>3</sup> |
|-----------|-----------------------|--------------------------------------------------------------|------------------------------|-------------------------|-------------------------------------|------------------------------------------------|
| USGS      | Location <sup>1</sup> |                                                              | Depth <sup>2</sup> (feet)    | Feet below land surface | Stratigraphic correlation           |                                                |
| 3/13-7N1  | 1418                  | Formerly General Petroleum Corp.                             |                              |                         | Silverado(?) zone                   | LADWP                                          |
| 8L2       | 1437G                 | H. N. Edison, formerly by Mrs. Bushby.                       | 254                          |                         | Silverado zone                      | LADWP, USGS                                    |
| 17Q1      | 1439A                 | H. Hellmers                                                  | 341                          | 119-330                 | do                                  | LADWP                                          |
| 18G2      | 1418F                 | Union Oil Co.                                                | 384.0                        |                         | do                                  | LADWP, USGS                                    |
| 20C1      | 1439F                 | G. L. Douglas                                                | 403                          | 183-243                 | do                                  | LADWP                                          |
| 28P1      |                       | Gardena Syndicate.                                           | 401.0                        | 284-340                 | do                                  | USGS                                           |
| 32F2      | 833A                  | John Larronde                                                | 750                          |                         | do                                  | LADWP, USGS                                    |
| 33B1      | 853A                  | I. W. Hellman Estate.                                        | 375                          |                         | do                                  | LADWP                                          |
| 33E1      |                       | Union Oil Co.                                                | 700                          | 272-480                 | do                                  | LADWP                                          |
| 3/14-4N1  | 1846B                 | Southern California Water Co., Truro plant, well 1.          | 636                          | 318-636                 | do                                  | SCWC                                           |
| 11M1      | 1377                  | Formerly by Johnson Ranch.                                   | 200                          |                         | "200-foot sand"                     | USGS, LACFCD                                   |
| 13J2      | 1409A                 | Southern California Water Co., Southern plant, well 2.       | 582                          | 236-556                 | Silverado zone                      | SCWC                                           |
| 14M1      | 1379                  | O. T. Johnson Ranch, well 5.                                 | 440                          | 332-380                 | "400-foot gravel"                   | LADWP                                          |
| 21B1      | 1349                  | Rosecrans plant, well 1.                                     | 468                          |                         | Silverado zone                      | SCWC                                           |
| 23L1      | 770D                  | Compton plant, well 1.                                       | 397                          | 334-353                 | "400-foot gravel"                   | SCWC                                           |
| 25E2      | 791                   | Baust                                                        | 38                           |                         | Semiperched water body.             | LADWP                                          |
| 25K3      | 802B                  | A. J. Walter                                                 | 30                           |                         | do                                  | LACFCD                                         |
| 26C3      | 781A                  | C. G. Pursche, formerly by C. C. Jorgensen.                  | 205                          |                         | "200-foot sand"                     | USGS, LADWP                                    |
| 35R1      | 794                   | Southern California Edison Co., Ltd., (Torrance substation). | 550                          | 470-548                 | Silverado zone                      | Owner, LACFCD                                  |
| 36M3      | 793B                  | W. H. Seward, formerly by Luckensmeyer.                      | 315<br>193.0                 |                         | "200-foot sand"                     | LADWP, LACFCD, USGS                            |
| 3/15-12L1 | 1297                  | City of El Segundo: Well 1                                   | 355                          | 236-355                 | "200-foot sand" and Silverado zone. | LADWP                                          |
| 12L5      | 1297G                 | Well 8                                                       | 380                          | 207-312                 | do                                  | Owner.                                         |
| 12L6      | 1297F                 | Well 7                                                       | 350                          | 222-320                 | do                                  | Do.                                            |
| 25A1      | 701A                  | City of Manhattan Beach: Well 3                              | 547                          | 204-280                 | Silverado zone                      | LADWP, LACFCD, USGS                            |
| 25H2      | 701C                  | Well 4                                                       | 395.0                        | 239-265                 | do                                  | LADWP                                          |
| 4/13-14K1 | 897                   | H. E. Diekson                                                | 114.3                        | 86-114                  | Gaspur zone                         | JBL, DWR                                       |
| 14L1      | 887F                  | do                                                           | 29.5                         | 25-30                   | do                                  | LB, LACFCD                                     |
| 14P1      |                       | City of Long Beach.                                          |                              |                         | Semiperched water body.             | USGS                                           |
| 15A8      | 876E                  | Dominguez Water Corp., well 5.                               | 980                          | 744-980                 | Silverado zone                      | Owner.                                         |

See footnotes at end of table, p. 119.

TABLE 12.—Wells in or near the west basin for which hydrographs are plotted on figures 4 and 5 and plates 13 and 14—Continued

| Well          |                            | Owner's name and well                                                                                     | Water-yielding zone or zones |                                  |                                     | Agency supplying principal record <sup>3</sup> |
|---------------|----------------------------|-----------------------------------------------------------------------------------------------------------|------------------------------|----------------------------------|-------------------------------------|------------------------------------------------|
| USGS          | Loca-<br>tion <sup>1</sup> |                                                                                                           | Depth <sup>2</sup><br>(feet) | Feet<br>below<br>land<br>surface | Stratigraphic<br>correlation        |                                                |
| 21H3.....     | 858B                       | Richfield Oil Corp., well 3.<br>City of Long Beach,<br>Silverado well 1.                                  | 800                          | 430-788                          | Silverado zone.....                 | LADWP, owner.                                  |
| 23G2.....     | 888H                       |                                                                                                           | 1,074                        | 696-1,066                        | .....do.....                        | LB                                             |
| 29M1.....     | 320                        | Robert Tracy.....                                                                                         | 68.5                         | -----                            | Unnamed upper Pleistocene deposits. | LACFCD                                         |
| 33D1.....     | 341D                       | City of Los Angeles,<br>Wilmington plant, well 14.<br>California Water Service Co.,<br>station 3, well 4. | 888.2                        | 669-800                          | Silverado zone,<br>lower part.      | LADWP, USGS                                    |
| 4/14-8E1..... | 725                        |                                                                                                           | 440.5                        | 140-373                          | Silverado zone.....                 | LADWP, owner,<br>USGS                          |
| 13F1.....     | 797                        | David E. Crutcher.                                                                                        | 697.0                        | 245-660                          | .....do.....                        | LADWP, USGS                                    |
| 22D1.....     | 768                        | Standard Oil Co.,<br>producing and pipeline dept.,<br>well 1.                                             | 404                          | 206-404                          | .....do.....                        | LACFCD, USGS                                   |

<sup>1</sup> Number assigned by California Division of Water Resources.

<sup>2</sup> Depths below land-surface datum indicated in whole feet are reported; those to a tenth of a foot are measured by Geological Survey.

<sup>3</sup> Names of agencies used in this table are identified as follows: DWR, Division of Water Resources, State of California; JBL, J. B. Lippincott; LACFCD, Los Angeles County Flood Control District; LADWP, Los Angeles Department of Water and Power; LB, city of Long Beach; SCWC, Southern California Water Co.; USGS, U. S. Geological Survey.

water-bearing zones were about equal and were about 20 feet above sea level in 4/13-23D. By 1924, levels for both zones had been drawn down but the level of the Silverado water-bearing zone at well 21H3 was about 20 feet below sea level and some 25 feet below the pressure head in the Gaspur zone (fig. 5C). The differential increased to about 40 feet by 1930, remained nearly constant to 1941, and increased to about 60 feet by 1946 (high levels for the year for hydrographs 4/13-14L1 and 4/13-23G2). This increasing differential in pressure levels for the two water-bearing zones is indicative of the lack of hydraulic continuity between them. The Gaspur zone here is highly contaminated by oil-field brine, however (p. 258 to 260), and with this pressure differential, which currently is equivalent to some 25 pounds per square inch, the contamination poses a serious threat to the pure water of the Silverado water-bearing zone. Because the two zones are separated by beds of low permeability, contaminated water is more likely to move downward through wells whose casings are either perforated or rusted through in both zones.

The history of changes in the regimen of the Gaspur water-bearing zone both within and inland from the Dominguez Gap have been treated in some detail in another report (Poland, 1959).

For the semiperched water table in Dominguez Gap, the hydrograph of well 4/13-14P1, from 1941 through 1946 (also plotted on fig. 5C) shows that the position of the water table in recent years has been essentially equal to that of the pressure level in the Gaspur zone beneath.

Wells 4/13-29M1 and 33D1, in Wilmington and about 3 miles southwest of well 4/13-23G2, tap the unnamed upper Pleistocene deposits and the lower part of the Silverado zone (table 12). Hydrographs for these wells (fig. 5C) illustrate the trends and increasing differential between the water levels in these two aquifers at that place since 1931.

In 1904, under essentially native conditions of head, the water level in both aquifers was about 13 feet above sea level. In the upper Pleistocene deposits the water level had been drawn down to about 20 feet below sea level by 1931, was about constant into 1938, recovered to 17 feet below sea level by 1942, and then declined to 22 feet below sea level by 1946. The pressure level for the lower part of the Silverado water-bearing zone (well 33D1) had been drawn down to 31 feet below sea level by 1932, was about constant to 1942, and then was drawn down to 47 feet below sea level by 1946. Thus, the head differential between these two aquifers increased from nothing in 1904 to about 11 feet in 1932, and to 25 feet in 1946 (high level for the year).

At the Wilmington well field of the city of Los Angeles, a 240-foot section of fine sand and silt separates the upper and lower parts of the Silverado water-bearing zone; this section occurs from about 460 to 700 feet below land surface. Water-level measurements for well 4/13-33E6, not plotted on figure 5, indicate that the pressure level in the upper part of the Silverado water-bearing zone was about 21 feet below sea level in 1927, 24 feet in 1930, and 32 feet in 1946 (high levels for the year). Thus, by 1946, the pressure level for the upper part of the Silverado was about 10 feet below that of the unnamed upper Pleistocene deposits and about 15 feet above that of the lower part of the Silverado water-bearing zone (well 33D1).

#### GARDENA AREA

Four distinct and separate water-bearing zones in the Gardena area are tapped by wells. These zones and their approximate depths below land surface are as follows: (1) The semiperched water body to about 80 feet; (2) the "200-foot sand" in the unnamed upper Pleistocene deposits from 140 to 260 feet; (3) the "400-foot gravel" in the upper part of the San Pedro formation, from 320 to 400 feet; and (4) the Silverado water-bearing zone in the lower part of the San Pedro formation, from 500 to 700 feet (pl. 3B).

On figure 5B, hydrographs for wells 3/14-25E2 and 25K3 show the position of the water table in the semiperched water body from 1929 through 1945; the hydrograph for well 3/14-36M3 shows the pressure level in the "200-foot sand" from 1929 through 1946; hydrographs for wells 3/14-14M1 and 23L1 show the pressure level in the "400-foot gravel" for the same period; and hydrographs for wells 3/14-35R1 and 3/14-32F2 show the pressure level of the Silverado water-bearing zone from 1924 through 1946.

The record for the "200-foot sand" is extended back to 1904 by the hydrographs for wells 3/14-11M1 and 26C3 (fig. 4A). For the "400-foot gravel," although wells 3/14-14M1 and 3/14-23L1 are a mile apart, and although the hydrograph for well 3/14-23L1 indicates a pressure head about 5 feet below that of well 3/14-14M1 early in 1941 when well 3/14-23L1 was completed and placed in service, the two hydrographs are believed to represent the changes in pressure surface during the period of record. In confirmation, well 3/14-10C1, which also taps the "400-foot gravel" is 2.5 miles northwest of well 23L1; in 1945 the pressure level in well 10C1 (not shown on fig. 5) was only about 2 feet above that for well 3/14-23L1 in March and identical with it in December.

For the Silverado water-bearing zone, well 3/13-32F2 is 2.6 miles east of well 3/14-35R1 and only about a mile from the east boundary of the west basin. Nevertheless, from mid-1944 to the end of 1946, frequent measurements (at least biweekly) of depth to water in each of these wells indicated essentially an identical position of water level throughout the yearly range. In fact, the pressure level of these years in well 3/14-35R1 was not plotted on figure 5B because the graph would have been confused with that for well 3/13-32F2. For earlier years also, the levels for both can be considered coequal, as is shown by the position of the random measurements in well 35R1 as related to the hydrograph for well 3/13-32F2.

For the four water-bearing zones in the Gardena area, the changes in water levels that have occurred since 1904 can be summarized as follows, utilizing high level for the year if known:

1. In 1904, Mendenhall's data show that the water levels in the several water-bearing zones were about equal but increased slightly in altitude with depth of zone. For example, the water table of the semiperched zone and the pressure surface of the "200-foot sand" were both from about 15 to 25 feet above sea level, but the pressure surface of the Silverado water-bearing zone was from 25 to 30 feet above sea level.
2. By 1920, the water level in the "200-foot sand" had been drawn down to about 10 feet above sea level (well 3/14-26C3, fig. 4A) and that of the Silverado water-bearing zone had been drawn down to sea level (measurement by the Southern California Edison Co. in well 3/14-35R1).
3. In 1929, the water table of the semiperched body was 16 feet above sea level; and the pressure surfaces for the "200-foot sand," the "400-foot gravel," and the

## 122 GEOLOGY, HYDROLOGY, TORRANCE-SANTA MONICA AREA

Silverado water-bearing zone were respectively 2, 5, and 18 feet below sea level (fig. 5B).

4. By 1941, levels in the four zones were respectively 19 feet above sea level (25E2); 14 feet below sea level (36M3); 15 feet below sea level (14M1); and 22 feet below sea level (32F2).

5. As of 1946, levels were respectively 12 feet above sea level (extrapolated), and 18 feet, 29 feet, and 38 feet below sea level. Thus, as of 1946, and with respect to high levels for the year, the pressure level in the Silverado water-bearing zone was 50 feet below the semiperched water table, 20 feet below the pressure level of the "200-foot sand," and about 9 feet below that of the "400-foot gravel."

### VICINITY OF INGLEWOOD

In the vicinity of Inglewood, the hydrographs for wells 2/14-32C1 and 3/14-4N1, shown on plate 13, indicate conditions of change in head in the "200-foot sand" (32C1) and in the Silverado water-bearing zone (4N1) from the early thirties through 1945. These wells are about 2 miles apart. Several hundred acre-feet of water is withdrawn each year from well 3/14-4N1, whereas well 2/14-32C1 is used solely as an observation well. Thus, their hydrographs do not furnish an absolute comparison of static water levels at one place. However, they do indicate the increasing differential in head between the two zones in a general way.

In 1904, water levels in both the "200-foot sand" and the Silverado water-bearing zone near the sites of these wells were about 25 feet above sea level. By 1933, the head in the "200-foot sand" was at sea level and that of the Silverado was about 8 feet below sea level. The pressure heads of both aquifers declined continuously from 1933 to 1945; by 1945, the head in the "200-foot sand" at well 2/14-32C1 was about 17 feet below sea level and the head in the Silverado at well 4N1 was about 40 feet below sea level. Thus, the head differential between the two aquifers, which was zero in 1904 increased by 1945 to 23 feet (high for the year) and about 50 feet (low for the year).

### FLUCTUATIONS AND CHANGE IN HEAD IN THE SILVERADO WATER-BEARING ZONE

Figure 5 and plate 13 include hydrographs for 20 wells or groups of wells in the Torrance-Inglewood subarea that tap the Silverado water-bearing zone or correlative aquifers in the San Pedro formation. These wells were selected to give a wide and representative geographic distribution (pl. 11).

### AREA SOUTH OF REDONDO BEACH BOULEVARD

With regard to the southern part of the area, figure 5 shows hydrographs for two wells in the water-table reach between Torrance and Redondo Beach—for well 4/14-8E1, 0.9 mile from the coast, and well 4/14-22D1, 2.3 miles from the coast; also for eight wells in the confined or pressure area between Torrance and Long Beach wells 4/14-13F1,

3/14-35R1, 3/13-33E1, 3/13-32F2, and 4/13-15A8, 21H3, 23G2, and 33D1. From west to east, these hydrographs show great differences in (1) the character and amplitude of the seasonal fluctuations, and (2) the rate and amount of decline in pressure head.

The seasonal fluctuations have been small in the water-table area west of Torrance and have become progressively greater to the east in the confined or pressure area. For example, in water-table well 4/14-8E1 the seasonal fluctuation has ranged from 1 to 3 feet, and since 1943, when pumping at this well ceased, the fluctuation has been about 1.5 feet per year. The graph from a water-level recorder operated on this well by the Geological Survey showed a daily fluctuation of as much as 0.1 foot, which was correlated with the tidal fluctuation at Los Angeles Outer Harbor. This correlation indicated a tidal efficiency of about 1.4 percent but with an 8-hour lag in registration. Well 4/14-22D1 is 2 miles farther from the coast and only about 200 feet from a pumped well. Even though the hydrograph shows the effect of the nearby pumping, the seasonal range commonly has not exceeded 4 feet.

Within the pressure area, the seasonal fluctuation has ranged from about 5 feet at well 4/14-13F1 in Torrance to as much as 20 to 25 feet at well 4/13-23G2 (city of Long Beach, Silverado well) in Dominguez Gap. Well 4/13-23G2 is an unused observation well a mile from the nearest active well tapping the Silverado water-bearing zone (4/13-22K1, used for irrigation); also 1.2 and 1.7 miles from the well field of the Dominguez Water Corp. (in 4/13-15A), and the Richfield Oil Corp. (in 4/13-21H). Each of these well fields is a locus of heavy draft (pl. 12, plants 14b and 26). The seasonal range shown by the hydrograph for well 4/13-23G2 was only about 13 feet from 1933 to 1938 but has nearly doubled with the accelerated withdrawal during the forties.

Most of the draft in the vicinity of Dominguez Gap is caused by continuous demands of industrial plants; the draft is about as heavy in winter as in summer. Therefore, the hydrograph for well 4/13-23G2 might be expected to show little, if any, seasonal fluctuation. However, the draft by the Dominguez Water Corp., which is the largest single draft of the area, does vary substantially from winter to summer, because part of the withdrawal is for irrigation and domestic use. The monthly draft by this corporation from January 1943 to June 1944, inclusive, has been plotted on figure 5C to show its relation to the seasonal fluctuation in pressure level in well 4/13-23G2. The correspondence is reasonably good, although the pressure level of well 4/13-23G2 is affected by other nearby pumping; it is possibly most strongly affected by the intermittent pumping of irrigation well 4/13-22K1.

The decline in the pressure head of the Silverado water-bearing zone in the southern part of the Torrance-Inglewood subarea has ranged from an average of about half a foot per year near Redondo Beach to as much as 2 feet per year in Dominguez Gap. At well 4/14-8E1 (in Redondo Beach), the water table has declined 10 feet from 1928 to 1946—an average yearly rate of 0.55 foot. In Dominguez Gap, some 10 miles to the east, the decline in the pressure head from 1924 to 1946, shown by the composite hydrograph for wells 4/13-21H3-23G2, has been 46 feet, and has occurred very largely in two widely separate periods. From 1924 to 1927 the decline was 20 feet, or about 7 feet per year; and from 1941 into 1946, during the war period, it was 26 feet, or about 5 feet per year.

#### AREA BETWEEN GARDENA AND THE BALLONA ESCARPMENT

For the central part of the west basin south of the Ballona escarpment, plate 13 shows hydrographs for eight wells or groups of wells which tap the confined reach of the Silverado, as follows: 3/15-12L1, L6, and L5, at El Segundo; 3/15-25H2 and A1 at Manhattan Beach; 3/14-21B1, 3/14-13J2, 3/13-18G2, and 3/13-20C1, all near Rosecrans Avenue; and 3/14-4N1 and 2/14-34C1 near Inglewood. Wells 2/15-34H1 and 34K1, whose hydrographs also are shown, tap the main aquifer of the San Pedro formation (believed correlative with the Silverado water-bearing zone) in the water-table reach near Playa del Rey (pl. 11).

In the confined reach of the Silverado water-bearing zone, near the coast at the municipal well field of El Segundo, hydrographs for wells 3/15-12L1, L6, and L5 suggest a seasonal fluctuation of about 2 feet if pumping effects are disregarded. Three miles inland and south of Hawthorne, the pressure level at well 3/14-21B1 varied about 10 feet per year in the middle thirties and the annual range increased to about 15 feet by the early forties. The joint discharge of wells 21B1 and 21B2 has ranged between 350 and 711 acre-feet per year since 1940. At the east margin of the west basin, the pressure level in well 3/13-18G2 fluctuated about 10 feet per year in 1945 and 1946, but the range in pumped well 3/14-13J2 has been as much as 23 feet (in 1945).

Throughout the central part of the west basin most of the water is pumped for domestic and irrigation use. Thus, the draft is heaviest late in the summer and it is lightest from December to March. The pressure levels in wells fluctuate in direct ratio to draft demands. This general seasonal fluctuation, which is greatest far within the confined reach of the Silverado water-bearing zone and near the centers of heaviest pumping, may be accompanied by a seasonal compression of the aquifer and the confining beds developed by the re-

duction of artesian pressure in the summer, when pumping is most intensive, and expansion of the beds caused by the gradual increase of pressure as water moves into the compressed parts of the formation during winter months. Such an explanation has been suggested by Fiedler (1944, p. 244-245) for similar fluctuation in the Roswell artesian basin. The subject of compressibility of artesian aquifers has been treated in more detail by Meinzer (Meinzer and Hard, 1925, p. 73-95; Meinzer, 1928, p. 263-291).

As in the water-table area near Redondo Beach, the seasonal fluctuations of the water table near Playa del Rey, at wells 2/15-34H1 and 34K1, have been very small—in most years the range in level has not exceeded 0.5 foot. The nearest heavy draft is at El Segundo, about 2.7 miles southeast from these wells as shown by plate 12. The only local withdrawal is from wells 2/15-34A1 and K1 (wells 3 and 1 of the Palisades del Rey Water Co.). In 1945 their joint draft was about 170 acre-feet.

The drawdown of about 1 foot in the water table at well 2/15-34H1, which persisted from February 1935 to April 1937, was induced by a temporary increase in draft from wells of the Palisades del Rey Water Company, as follows: 89 acre-feet in 1933; 87 acre-feet in 1934; 328 acre-feet in 1935; 147 acre-feet in 1936; 102 acre-feet in 1937; and 99 acre-feet in 1938. An active but temporary drilling program in 1935 in the so-called Del Rey Hills segment of the Playa del Rey oil field received most of its water supply from the wells of this company.

The water table in well 2/15-34K1 consistently stood about 2 feet above sea level in the thirties, but from the end of 1940 to the end of 1941 the level rose from 2.6 to 3.8 feet above sea level. Rainfall was very heavy in the water year 1940-41; at Los Angeles it was about 210 percent of the 68-year average (table 2), and the greatest since 1889-90. The unique rise in water level in well 34K1 was caused by recharge from this rainfall. The peak rainfall was in February and March (12.42 and 8.14 inches at Los Angeles); the water-table peak was in November-December, indicating a 9-month lag in maximum rate of recharge at the water table. The water from rainfall here must pass through about 80 feet of dune sand to reach the water table.

The average rate of downward movement of water from rainfall at well 34K1 in 1941 apparently was about 9 feet per month, only about 3 percent as rapid as the rate of 10 feet per day cited by Sopp (1929, p. 2227) for penetration through 150 feet of Recent alluvium near Pasadena, Calif. Possibly the slow rate of movement was caused by the restraining effect of two beds of clay (7 and 9 feet thick) reported in the log for this well to be present within the dune sand. It is not



known why the water table at well 2/15-34H1, 2,900 feet northeast of well 34K1, did not show a similar response, although a rise and decline may have occurred between the May and October measurements of 1941.

As shown by the hydrographs of plate 13, the decline in the pressure head of the Silverado water-bearing zone in the central part of the west basin (between Gardena and the Ballona escarpment) has differed widely from place to place.

Within the confined reach, about 1.2 miles from the ocean at the main well field of El Segundo, water levels were about 3 feet below sea level in the early thirties and about 4 feet below sea level in 1941 (wells 3/15-12L1-12L6); thus, these levels declined about a foot in 10 years. From 1942 through 1946 the decline was 8 feet, or nearly 2 feet per year. Wells at the main well field of Manhattan Beach (3/15-25A1) have shown about the same character and rate of pressure decline.

On the other hand, near the central synclinal axis of the west basin at well 3/14-4N1 (north of Hawthorne) the decline in pressure head was nearly uniform from 1933 to 1940 at about 2 feet per year, and then increased to more than 3 feet per year to 1946; at well 3/14-21B1, south of Hawthorne, the rate of decline was about 1.3 feet per year from 1930 to 1941 and about 3 feet per year from 1941 to 1946.

In the water-table reach near Playa del Rey (wells 2/15-34H1 and K1), water levels were essentially stable from 1930 through 1944 but declined about 2 feet in 1945-46. Because water levels to the north, east, and south were below sea level as early as 1933 (pl. 9), the water table of the Playa del Rey area must have been maintained at or above sea level since the early thirties by recharge from rainfall. Thus, the recharge from rainfall in this area is shown to have been more than sufficient to supply the draft from the wells of the Palisades del Rey Water Co. However, in 1945 the regional cone of water-level lowering reached wells 34H1 and 34K1 and caused a steady if slow decline. It is interesting to note that the chloride concentration of water from well 34K1 has increased sharply since January 1945 (fig. 15), coincident with the decline in water level.

#### FLUCTUATIONS IN THE CULVER CITY SUBAREA

As discussed previously, the part of the west basin in and north of Ballona Gap includes three semi-independent subbasins formed by the partitioning effect of the Overland Avenue and Charnock faults. Water levels in the three subbasins have fluctuated in widely differing fashion. The hydrographs of plate 14 bring out some of the most marked differences:

## COASTAL AREA

Wells 2/15-16F1 and 2/15-22B4, respectively, tap the "50-foot gravel" and the San Pedro formation in the coastal area west of the Charnock fault. Hydrographs for these wells (pl. 14) indicate that spring water levels in the two aquifers were essentially equal; in the thirties, the pressure head in the San Pedro formation at well 22B4 had a greater seasonal range than did that of the "50-foot gravel" at well 16F1, but this fluctuation was induced by nearby pumping for irrigation.

In 1904, water levels were about 5 feet above sea level near well 16F1 and 8 feet above sea level near well 22B4. By 1930 the levels had been drawn down about 10 feet below sea level at both wells. Records are not available to define when this drawdown developed; but presumably, most of it occurred in the twenties, when pumping for irrigation was most intensive. By 1930, the front of saline contamination had passed inland beyond both wells (pl. 16), and local draft was decreasing.

The hydrographs show a slow and relatively uniform recovery of water level from 1931 to 1941 in well 16F1, and a similar but irregular recovery in well 22B4; this recovery was caused by a decrease in irrigation draft as saline encroachment became more extensive (pl. 16). In the spring of 1941 the levels rose several feet, coincident with cessation of pumping at the Marine plant of the city of Santa Monica (in 2/15-9N); in 1940 this draft had been 944 acre-feet. Also the recovery of water level in 1941 probably was partly due to the increased replenishment during the wet winter of 1940-41. At well 16F1 the recovery continued until 1944, when the level stood a foot above sea level, and the "ground-water hole" of the early thirties had completely disappeared (pls. 9-12).

Well 2/15-23F1, about 4,000 feet east of well 22B4, taps the semi-perched water body overlying the "50-foot gravel." The hydrograph (pl. 14) suggests that, the water table of the semiperched body generally stood a few feet above the water level of the underlying aquifers in the late thirties, but has been essentially coincident since 1941.

## CHARNOCK SUBBASIN

Very few of the wells in the Charnock subbasin for which water-level records are available tap only the "50-foot gravel." Many small wells which formerly tapped this aquifer have gone dry and have been abandoned, such as well 2/15-1P3 (fig. 4). The hydrograph for this well indicates that the water level in the "50-foot gravel" declined fairly uniformly from 1904 to 1911 and from 1918 to 1926; the hydrograph for well 2/15-1P2 continues the record of the decline to 1946. Both wells are close to the Overland Avenue fault

which, however, does not interrupt hydraulic continuity within the "50-foot gravel." The hydrographs indicate that this aquifer does not have hydraulic continuity with the main aquifer of the San Pedro formation beneath, because the pressure levels of the latter aquifer have followed an entirely different trend. Hydrographs for wells 2/15-11F4 and 2/15-11E3 at the Charnock plant of the Southern California Water Co. and for well 2/15-24C1, about 2 miles southeast, illustrate the fluctuations since 1930 in the San Pedro formation (pl. 14).

In 1904 the water level in 2/15-11C was from 30 to 35 feet above sea level and in 2/15-24C it was about 16 feet above sea level. In 1925 the level at well 2/15-24C1 was 11 feet above sea level, thus indicating a decline in head of only about 5 feet since 1904.

In 1925 the city of Santa Monica completed its first well at the Charnock municipal field in 2/15-11C; about 1927 the Southern California Water Co. began taking water from its Charnock well field in 2/15-11E and 2/15-11F, and the draft became very heavy before 1930. This concentrated withdrawal from the NW $\frac{1}{4}$  sec. 11 has been the controlling factor in the fluctuation of the pressure level in the main aquifer of the San Pedro formation throughout the Charnock subbasin since 1926. The heavy draft at these fields was supplemented by pumping at the Sepulveda plant of the Southern California Water Co. in well 2/15-11J, which also commenced in 1926. Together, these withdrawals produced a cone of perennial drawdown which rapidly extended to the north and south but was terminated abruptly on the west by the Charnock fault barrier, and was limited on the east by the more distant Overland Avenue fault. A water-level contour map of the high level for 1930 (not included in this report) shows that pressure levels at the Charnock well fields then were 20 to 30 feet below sea level; in addition, the map shows that water levels had been drawn down below sea level southward about 2 miles, or to Ballona Creek (see hydrograph for well 24C1), and northward about three-quarters of a mile, or about halfway to Pico Boulevard.

The hydrographs for wells 2/15-11F4 and 11E3 illustrate the great drawdown of water level that occurred at this center of pumping from 1931 to 1940, inclusive. The combined yearly draft from the Charnock well fields by the city of Santa Monica and by the Southern California Water Co., also illustrated on plate 14, increased from 6,070 acre-feet in 1931 to 9,190 acre-feet in 1940. Withdrawal by Santa Monica decreased about one-half in 1941 and was negligible by 1942 (the total draft from the Charnock fields was 2,505 acre-feet at this time). In response to this variation in concentrated draft, the water level in well 11E3 was drawn down to 100 feet below sea level by 1940 but

recovered about 45 feet by 1945 and became temporarily stabilized about 55 feet below sea level. It should be noted that this well is pumped and is in the midst of other pumped wells; hence the level for this well illustrated on plate 14 represents a "recovery" level observed while well 11E3 was idle but while other wells were pumped. Thus, it shows the over-all drawdown at the well field.

Water levels in other wells tapping the San Pedro formation in the Charnock subbasin have fluctuated primarily in response to the draft at the Charnock well fields. For example, well 2/15-24C1 is 2 miles southeast from the Charnock fields and has not been pumped since 1935. Its pressure-level graph is a reduced replica of the hydrographs for wells 11F4 and 11E3 and shows the same downward trend from 1930 (1925) through 1940 and a gentle recovery of about 4 feet from 1941 to 1945, inclusive.

#### CRESTAL SUBBASIN

The crestal subbasin occupies the narrow upthrown block between the Inglewood fault to the east and the Charnock fault to the west. In the San Pedro formation within this subbasin, movement of water is southward and the pressure levels now stand far above the drawdown levels to the west and east.

Records of water level by Mendenhall in 1904 and periodic measurements beginning in 1930 show that there was no change in the pressure head of the San Pedro formation in the crestal subbasin from 1904 to 1930. For example, measurements made by the Geological Survey in well 2/15-1F1 (Ebert, 1921, well 16) between 1904 and 1910 indicate that its pressure level then was 60 to 62 feet above sea level; it was still about 62 feet above sea level in 1930, as shown by a water-level contour map for the spring of 1930 prepared as a part of the present investigation. Also, about 2 miles to the south in 2/14-7M, the pressure level was 40 feet above sea level in 1904 and in 1930.

The hydrographs for wells 2/14-7M1 and 18F1 (pl. 14) show the change in pressure head that has occurred from 1930 to 1945, inclusive. The seasonal fluctuation has been less than a foot (a characteristic of wells in this subbasin). Decline of head began in 1931, was very gentle until 1936, increased in 1937, and then continued until 1945 at a fairly uniform rate—about 1 foot per year in well 7M1 and 2 feet per year in 18F1. Compared with the great range in water levels to the east and west, the change in pressure head in this subbasin has been surprisingly uniform and completely independent—attesting to a lack of hydraulic continuity within the San Pedro formation across the Inglewood and Charnock faults. The fluctuations of water level have been in response to change in draft within the subbasin. Perennial withdrawal has been chiefly by the Southern California Water Co. at its Manning plant in 2/15-1C,

beginning in the middle twenties; and by the Metro-Goldwyn-Mayer Corp. from wells 2/15-12B1 and 2/14-7P1, beginning in 1932. As described earlier (p. 108), the over-all draft did not exceed a few hundred acre-feet per year until the middle thirties; it was about 1,100 acre-feet in 1935 and in 1940, and about 1,600 acre-feet in 1945.

Water levels in wells at the Manning plant of the Southern California Water Co. show a seasonal fluctuation of as much as 10 feet, but their long-term trend has been in agreement with that of the hydrograph for well 2/14-7M1; water levels at the Manning plant are about 25 feet higher than at well 7M1.

Water levels in the "50-foot gravel" in the crestal subbasin have fluctuated in a different manner from those in the San Pedro formation, presumably because the "50-foot gravel" is hydraulically continuous across the barrier faults that are so effective in damming the older aquifer. Hydrographs for wells 2/15-1P2 and 1P3 (fig. 4) show the long-term decline in head in this aquifer. For the past two decades, draft from the "50-foot gravel" within the crestal subbasin has been negligible; hence the decline has been caused largely by decrease of inflow, and by continued outflow.

#### FLUCTUATIONS INDUCED BY PUMPING

Seasonal fluctuations related to pumping are discernible in most of the hydrographs for wells measured monthly or more frequently. Pumping draft for irrigation and other uses fluctuates not only with the season but also from day to day. Even wells supplying water to satisfy a reasonably constant industrial demand may be subject to momentary and frequent changes in rate of discharge if the system is operated with an automatic control and substantial storage facilities. These fluctuations of the water level in observation wells induced by such changes in the rate of withdrawal can be determined only by taking a continuous record of water level.

In connection with the operation of water-level recorders in wells, the Geological Survey has obtained many examples of these short-term fluctuations. Two records of particular interest are illustrated in figure 6.

Well 4/13-33D1 (city of Los Angeles, Wilmington plant, well 14) in Wilmington taps the lower part of the Silverado water-bearing zone from 669 to 800 feet below the land surface. The wells of the Texas Co. in 4/13-27M, 6,000 feet to the northeast, tap the full thickness of the Silverado water-bearing zone from 400 to 800 feet below the surface. In December 1941 well 4/13-27M4 (owner's well 6) was being pumped continuously at 850 gpm and well 27M3 (owner's well 5) was on automatic control, pumping intermittently at 3,000 gpm. Thus, the over-all discharge was at the base rate of 850

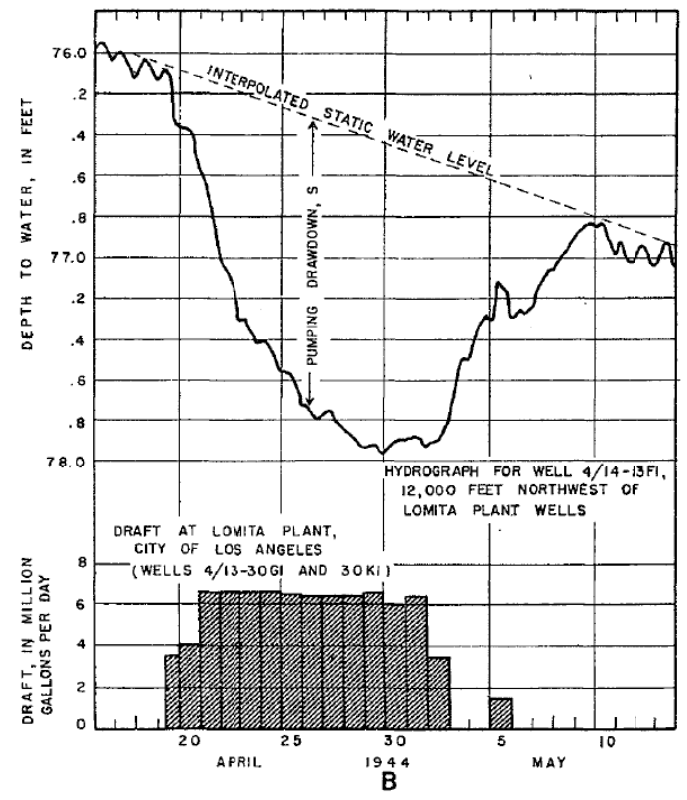
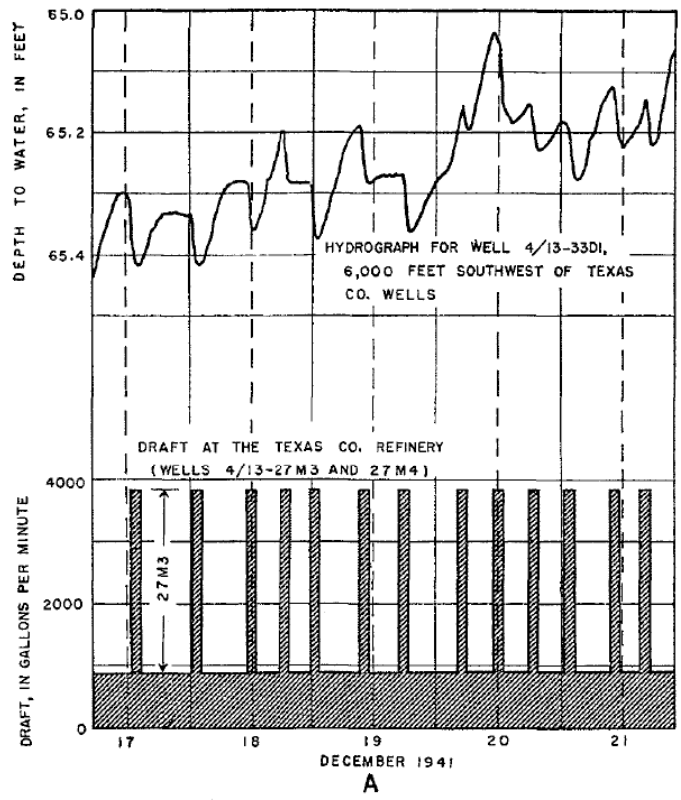

FIGURE 6.—Graphs showing fluctuations of water level in wells 4/13-33D1 and 4/14-13F1 induced by pumping of distant wells.

gpm with intermittent increase to 3,850 gpm (fig. 6). The plot of pressure head in well 4/13-33D1 indicates an immediate response to the pumping of well 27M3. During the time here graphed, the average length of each pumping period for well 27M3 was about 1 hour and the average drawdown in pressure level at well 33D1 induced by this pumping was about 0.08 foot. The drawdown at the pumped well was about 15 feet in 1941. The precise amount of time required for the transmission of the pressure effect through the 6,000-foot distance is not known but the graph indicates registration at well 33D1 within a very few minutes. Before the cause of the fluctuations was identified, the recorder had to be removed from the well and thus an expanded-time graph was not obtained.

Well 4/14-13F1, near Torrance, taps the full thickness of the Silverado water-bearing zone. The fluctuation of pressure head at this well from April 16 to May 13, 1944 is shown on figure 6 together with the combined daily draft from wells 4/13-30G1 and K1 (city of Los Angeles, Lomita plant, wells 6 and 7). The Lomita plant wells, located 12,000 feet southeast from well 4/14-13F1, also tap the Silverado. Their pumps had been idle for about 3 weeks before the beginning of pumping at 9:20 a. m. April 19. In the following 14 days (ending May 2), about 82,620,000 gallons (254 acre-feet) of water was withdrawn from the Silverado water-bearing zone through these wells, at an average discharge rate of 4,340 gpm. The hydrograph for well 13F1 shows that the drawdown of the pressure head caused by this pumping was superimposed on a general declining trend of about 0.04 foot per day. Before, during, and after the operation of the wells at the Lomita plant, the hydrograph for well 4/14-13F1 showed a diurnal fluctuation of about 0.1 foot; its cause is not known. As nearly as can be determined from the recorder graph for well 13F1, the pressure level at this well began to decline about 30 minutes after the pumps were turned on at the Lomita plant, about 2.3 miles distant. Considering the general trend, the drawdown in pressure level induced by the continuous operation of the Lomita plant was 1.1 feet after 4 days and 1.5 feet after 10 days.

Both the rate of response and the magnitude of drawdown at well 4/14-13F1 attest to the complete confinement of the Silverado water-bearing zone between Wilmington and Torrance. If this aquifer were unconfined in that area, it is doubtful if the effect of pumping at a distance of 12,000 feet could be detected from a recorder graph. Certainly a cone of water-table depression of appreciable depth would take many weeks to extend 12,000 feet from the origin.

By plotting on semilogarithmic coordinates the drawdown at well 4/14-13F1 against the time since the pumps at the Lomita plant were started (log scale), the graphical method developed by Cooper and

Jacob (1946, p. 526-534) can be used to determine transmissibility, permeability, and storage coefficient. As discussed on page 54, the transmissibility determined from these data is about 813,000 gpd per foot, and the indicated coefficient of permeability is about 2,000 gpd per square foot. The storage coefficient can be calculated by use of the equation:

$$S=2.25 T t_0/r^2$$

where  $S$  is the storage coefficient (volume of water that a unit decline of head releases from storage in a vertical prism of the aquifer of unit cross section),  $T$  is the transmissibility,  $t_0$  is the value of time at the drawdown intercept 0, and  $r$  is the distance of the observation well from the pumped well. The storage coefficient so derived from the semilogarithmic plot for drawdown in well 4/14-13F1 is 0.0012.

Figures 7 and 8—discussed in detail in the section on barrier features (p. 137 to 141)—also show drawdown fluctuations induced by pumping of nearby wells.

#### HYDROLOGIC EVIDENCE RELATING TO BOUNDARIES OF THE WEST BASIN

##### WATER LEVELS ACROSS THE BARRIER FEATURES OF THE NEWPORT-INGLEWOOD UPLIFT

The faults of the Newport-Inglewood uplift produce discontinuities in the pressure surfaces of the aquifers of Pleistocene age. Thus, the location of the fault barriers commonly can best be determined by constructing water-level contour maps and by relating hydraulic discontinuities to geologic or physiographic evidence of faulting. In places where the latter types of evidence are lacking or unknown, the hydraulic discontinuity may furnish the only proof of a fault barrier, and the accuracy of location then depends wholly on the water-level control. The inferred fault barrier passing southeastward along the Rosecrans Hills from the Potrero fault to the Avalon-Compton fault and the similar feature along the crest of Dominguez Hill both have been defined purely from hydrologic data as revealed on plates 9-12, and on hydrographs to be discussed.

The effectiveness of the faults as barriers to water movement can be evaluated in part from the magnitude of the hydraulic discontinuities across them, and by the gradients developed immediately inland and coastward. Both features are shown by the water-level contour maps. The effectiveness can be appraised also from simultaneous water-level fluctuations in two or more wells on opposite sides of such barrier features. In a recent report (Poland, 1959) such an appraisal has been made for the 22-mile reach of the Newport-Inglewood uplift from Dominguez Hill southeast to Newport Mesa.



From that appraisal and with respect to the reach within Los Angeles County—that is, from Dominguez Hill to the Orange County line near Seal Beach—it has been concluded (Poland, 1959) that:

In Dominguez Gap there is no barrier to movement through the Gaspar water-bearing zone of Recent age. In the underlying Silverado zone a substantial barrier has been developed but presumably it is not wholly watertight. Along the Signal Hill uplift the barrier features form a reasonably effective barrier to water movement but available evidence suggests that they are not wholly watertight against differential heads of several tens of feet. In Alamitos Gap, no barrier exists within the deposits of Recent age which extend to about 90 feet below land surface. However, the barrier across the underlying San Pedro formation is believed to be essentially watertight.

For the demonstration of the hydrologic evidence from which these conclusions were derived, the reader is referred to that report. In particular, attention is directed to the analysis of hydraulic conditions across the inferred extension of the Cherry-Hill fault in Dominguez Gap, (1) in the semiperched water body, (2) in the Gaspar water-bearing zone, and (3) in the Silverado water-bearing zone (Poland, 1959).

#### DOMINGUEZ HILL TO THE BALDWIN HILLS

To show hydraulic discontinuities across the 12-mile reach of the Newport-Inglewood uplift from Dominguez Hill northwesterly to the Baldwin Hills, selected data collected or assembled as a part of the present investigation are presented on five pairs or sets of hydrographs, as follows:

1. Across the ground-water barrier on the northwest flank of Dominguez Hill, hydrographs for well 3/13-33B1 (inland side) and well 3/13-33E1 (coastal side). (See fig. 5B.)
2. Across the south end of the Avalon-Compton fault, hydrographs for well 3/13-28P1 (inland side) and well 3/13-32F2 (coastal side). (See fig. 5B.)
3. Across the north end of the Avalon-Compton fault, hydrographs for well 3/13-17Q1 (inland side) and well 3/13-20C1 (coastal side). (See pl. 13C.)
4. Across the ground-water barrier along the central part of the Rosecrans Hills, hydrographs for wells 3/13-8L2 and 7N1 (inland side) and wells 3/13-18G2 and 3/14-13J2 (coastal side). (See pl. 13C.)
5. Across the Potrero fault east of the center of Inglewood, hydrographs for wells 2/14-27F1, 2, and 3 (inland side), and well 2/14-34C1 (coastal side). (See pl. 13D.)

All these wells tap the Silverado water-bearing zone, therefore the hydrologic data are common to this aquifer. The locations of these wells are shown on plate 11.

On the northwest flank of Dominguez Hill, wells 3/13-33B1 and 3/13-33E1 are about 2,700 feet apart (about 2,300 feet measured normal to the water-level contours). The record for well 3/13-33E1 spans only the years 1931-32. For these years seasonal fluctuation was about the same in both wells, but the pressure head in well 33E1

consistently stood 30 feet lower than that of well 33B1. Thus, the discontinuity shown on plate 9 (March 1933) is known to be an all-year feature. With reference to plate 9, if the approach gradient (inland side) and the escape gradient (coastal side) are projected to the inferred barrier a hydraulic discontinuity of about 25 feet is obtained. Although the measurements at well 33E1 ceased in 1933, the water-level contours of November 1945 (pl. 12) suggest that the actual discontinuity at the barrier had increased in the 12 years to nearly 40 feet.

The hydrographs for wells 3/13-28P1 and 32F2 also span a joint record of about 2 years, from 1944 to 1946. Well 3/13-28P1 is about 700 feet inland from the Avalon-Compton fault, and well 3/13-32F2 is about 4,500 feet coastward. The general character and amplitude of seasonal fluctuation are similar for the two wells. The differential in pressure head, which is about 50 feet, remained about equal throughout the 2 years. Hydrographs for wells 3/13-33B1 and 32F2 furnish a 15-year comparison of the fluctuation in wells which are 6,500 feet apart and on opposite sides of the barrier. They show that the difference between the pressure heads at the two wells has increased from 50 feet in 1931 to 66 feet in 1945.

Wells 3/13-17Q1 and 3/13-20C1, at the northwest end of the Avalon-Compton fault, are only 1,500 feet apart and nearly equidistant from the fault. The hydrographs for these wells, which extend from 1930 to 1945 (pl. 13C), show a striking difference in amplitude of seasonal fluctuation; the average for well 17Q1 is about 19 feet and the average for 20C1 is about 6 feet. The greater range in pressure head at well 17Q1 doubtless is caused by more intensive local pumping; however, the pressure effects are not transmitted to well 20C1 because of the fault barrier. The pressure differential at these wells was greatest in the early thirties—about 48 feet in February and 32 feet in August. In 1945 the differential had decreased to about 24 feet for both spring and autumn; this was due almost entirely to decline in head at well 17Q2 (successor to 17Q1 and tapping the same water-bearing beds).

On plate 13C, the hydrographs for wells 3/13-8L2 and 7N1 inland from the ground-water barrier along the Rosecrans Hills and those for wells 3/13-18G2 and 3/14-13J2 coastward from the barrier show a striking change during the 17-year period of record. Well 3/14-13J2 is one of the heavily pumped wells in the Gardena system of the Southern California Water Co. Well 3/13-18G2 was pumped by the Union Oil Co. until about 1942. So far as known the two inland wells have not been pumped during the period of record. From 1931 into 1937, the pressure-head differential between wells 3/13-8L2 and 18G2 decreased from 40 feet to 25 feet. In that same period

the head difference between wells 3/13-18G2 and 3/14-13J2 was constant at about 30 feet. From 1937 into 1941, the pressure head in well 3/13-18G2 declined about 30 feet; therefore, in 1941 a pressure differential of 52 feet had developed with respect to well 3/13-8L2. It is inferred that this drawdown of head in well 18G2 was caused by accelerated draft at the Southern plant of the Southern California Water Co. in 3/14-13J. By 1945 the high level for the year in well 18G2 was only about 4 feet above that for 3/14-13J2 and 57 feet below that for well 8L2. The record here discussed is considered to furnish indisputable evidence that well 3/13-18G2 is within the west basin and that it is hydraulically separated from the wells to the northeast by a ground-water barrier.

Hydrographs for wells 2/14-27F1, 2, 3, and 2/14-34C1 compare conditions across the Potrero fault at the north edge of the Rosecrans Hills (pl. 13D). Although the hydrograph for well 27F1 is shown here only from 1932, earlier measurements indicate a decline of head from 50 feet above sea level in 1930. The amplitude of seasonal fluctuation in well 27F1 has ranged from 5 to 7 feet; that in well 34C1 has ranged from 10 to 35 feet. From 1930 to 1939 the pressure head at well 27F1 was drawn down 49 feet, and the head in well 34C1 declined only 29 feet. On the other hand, from 1940 to 1945 the head in wells 27F2 and F3 (which tap the Silverado water-bearing zone also) declined only 2 feet, whereas the head in well 34C1 was drawn down 27 feet. This greatly accelerated drawdown of pressure head in well 34C1 is believed to reflect the increase in draft on the small subbasin in section 34 which was caused by the pumping of wells 34F1 and L2 (Hollywood Turf Club) beginning about 1941.

For the several pairs of hydrographs here discussed, the evidence indicates a substantial ground-water barrier at each place. The information gained from an appraisal of replenishment, however, indicates that the barrier features are by no means watertight throughout their extent under the range of differential heads that have prevailed across them in the past (see p. 159 to 161).

#### BALLONA GAP

Across the Inglewood fault in Ballona Gap, a striking hydraulic discontinuity has developed in the pressure head of the San Pedro formation through drawdown of head east of the fault by the joint draft of the Sentney plant of the Southern California Water Co. and the Castle plant of the city of Beverly Hills. Hydrographs are shown on plate 14 for wells 2/14-5D5 and 5F2 at and near the Sentney plant, respectively, inland from the fault, and for wells 2/14-7M1 and 18F1 in the crestal subbasin coastward from the fault. Although the latter two wells are more than a mile from the Inglewood fault and nearly 2

miles from the Sentney plant, their hydrographs represent fluctuation in the crestal subbasin. The contrast in the seasonal pattern and in the long-term trend needs no verbal emphasis. It is concluded from these graphs and from the shape of the water-level contours on plates 9-12 that between the Baldwin Hills and the Beverly Hills, the Inglewood fault presents an essentially water-tight barrier to movement in the San Pedro formation.

The water level in the "50-foot gravel" inland from the Inglewood fault was about 62 feet above sea level in 1946 (well 2/14-5D9)—about 90 feet above the pressure level in the San Pedro formation beneath (well 5D5). In the crestal subbasin coastward from the fault, the water level in the "50-foot gravel" as of 1946 was known only for well 2/15-1P2 (fig. 4), and was about 12 feet above sea level. Although the suggested gradient from well 5D9 to well 1P2 in 1946 was 25 feet per mile, it is inferred that no hydraulic barrier transects the "50-foot gravel" at the Inglewood fault. It is of interest to note that the gradient between these two places was 25 feet per mile in 1904 also, although the water level was about 30 feet higher at that time.

#### PUMPING TEST AT INGLEWOOD WELL FIELD

From January 3 to April 30, 1945, the Geological Survey operated a water-level recorder on well 2/14-27D1 (city of Inglewood, well 7), in the Centinela Park well field of the city of Inglewood, and 200 feet east of the Potrero fault. During the early part of the period of operation, it was noted that the water level in this well was drawn down several feet by the pumping of certain nearby wells in the Centinela Park field. With the cooperation of the Inglewood Water Department, a pumping schedule was arranged for the active wells in the Centinela Park field to determine the effectiveness of the Potrero fault as a barrier to water movement. The Inglewood Water Department kept a careful record of the pumping periods for the active wells in the field. The results of this pumping test are shown on figure 7.

As indicated by the plan of wells in the Centinela Park field (fig. 7), 9 of the 11 active wells in the field are east of the Potrero fault (in the main coastal basin) and 2 are west of the fault (in the west basin). All of the wells tap aquifers in the San Pedro formation, which is correlative with the Silverado water-bearing zone.

Figure 7 shows the drawdown in water level at well 27D1 caused by the pumping of well 22N2, 300 feet to the north. At the time, all other well pumps at the field were idle except those for wells 22P1 and 22P2, which were operated continuously through the period of record on the graph (March 5-12). The drawdown induced by pumping of well 22N2 was 3.8 feet after 46 hours of pumping. Obviously there is free hydraulic movement between these wells. As explained on page

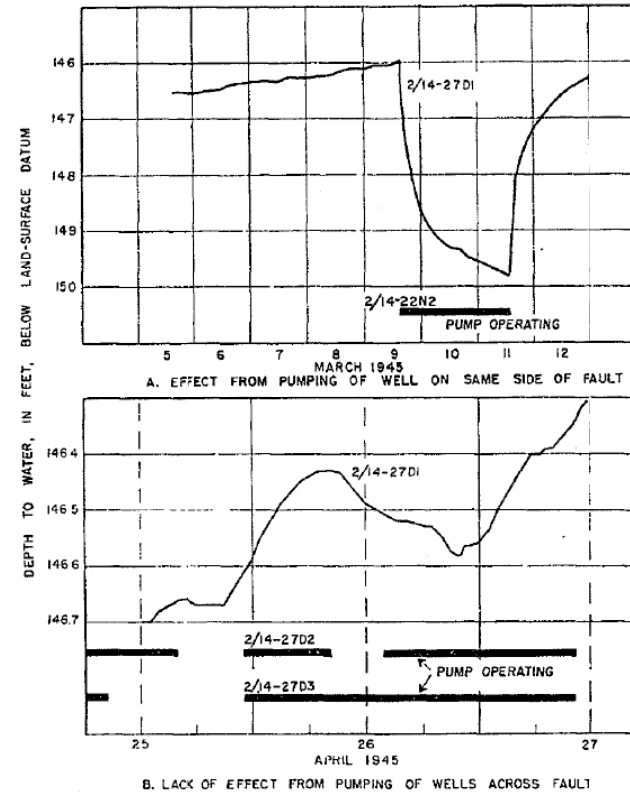
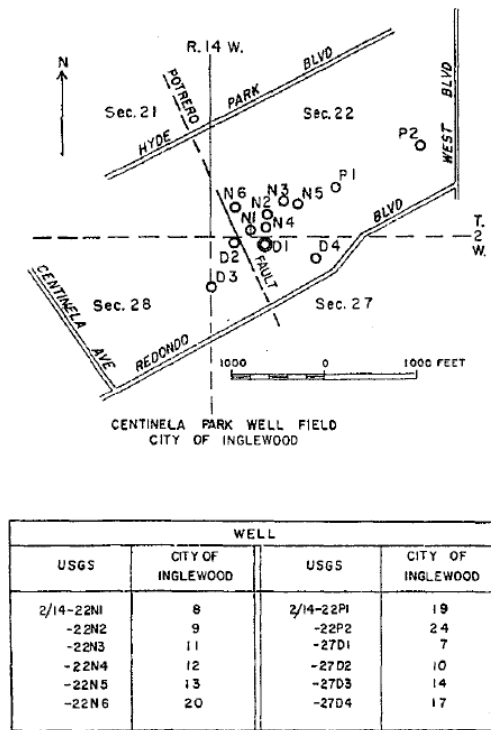

FIGURE 7.—Map of wells, and graphs showing fluctuations of water level in well 2/14-27D1 in Inglewood as related to pumping of nearby wells on opposite sides of Potrero fault.

55, this drawdown of water level in well 27D1 resulting from the pumping of well 22N2 was utilized in computing transmissibility and permeability of the water-bearing beds.

Figures 7 and 8 show the hydrograph for well 27D1 during the intermittent operation of the pumps in wells 27D2 and 27D3 (city of Inglewood, wells 10 and 14); both of these wells are west of the Potrero fault and are 325 and 725 feet, respectively, from well 27D1. For the period here graphed (6 a. m. April 25 to noon, April 27), two of the wells east of the fault 22P1 and 22P2 were operated continuously and all others were idle. Although the hydrograph for well 27D1 indicates drawdown and recovery of the water level in response to pumping, the fluctuations are not related to operation of the pumps in wells 27D2 and 27D3. For example, on April 25 the pumps in these two wells were started at 11:10 and 11:05 p. m., respectively, but the recovering water level in well 27D1 was not affected in the least. Clearly, the Potrero fault is an effective ground-water barrier within the head differentials imposed by this test. The drawdown in well 27D2 at the time of the test is not known. In November 1944 its level was drawn down to 30.7 feet below sea level after pumping for 15 minutes, or about 26 feet below the level in well 27D1. Presumably, the differential of April 25-27 was similar.

#### PUMPING TEST NEAR WILMINGTON

In September 1946, with the cooperation of the Union Oil Co., the Palos Verdes Water Co., and the Department of Water and Power of the city of Los Angeles, the Geological Survey made a pumping test near Bixby Slough, in Wilmington. This pumping test was made chiefly to determine whether a barrier to ground-water movement existed between the wells of the Union Oil Co. (4/13-31P1 and 5/13-6D2) and nearby wells at (1) the Lomita plant of the city of Los Angeles, in 4/13-31E, and (2) the Palos Verdes Water Co. property, in 4/14-36H. Figure 8 shows the relative locations of the wells, and graphs the results of the pumping test. All of the wells involved in the pumping test tap the Silverado water-bearing zone. Because the wells of the Union Oil Co., beginning with well 5/13-6D1 in 1922, always have yielded water of markedly different chemical quality from that yielded by the wells north of Anaheim Street (fig. 34), it had long been suspected that the Union Oil Co. wells might be separated from the west basin by a hydraulic barrier. For example, from the beginning of 1931 to the end of 1945 about 14,616 acre-feet of water was withdrawn from the Silverado water-bearing zone through the wells of the Union Oil Co. In 1931, the water yielded by well 5/13-6D1 contained about 500 ppm of chloride and 1,200 ppm of dissolved solids; as of 1945, the water from well 5/13-6D2 contained

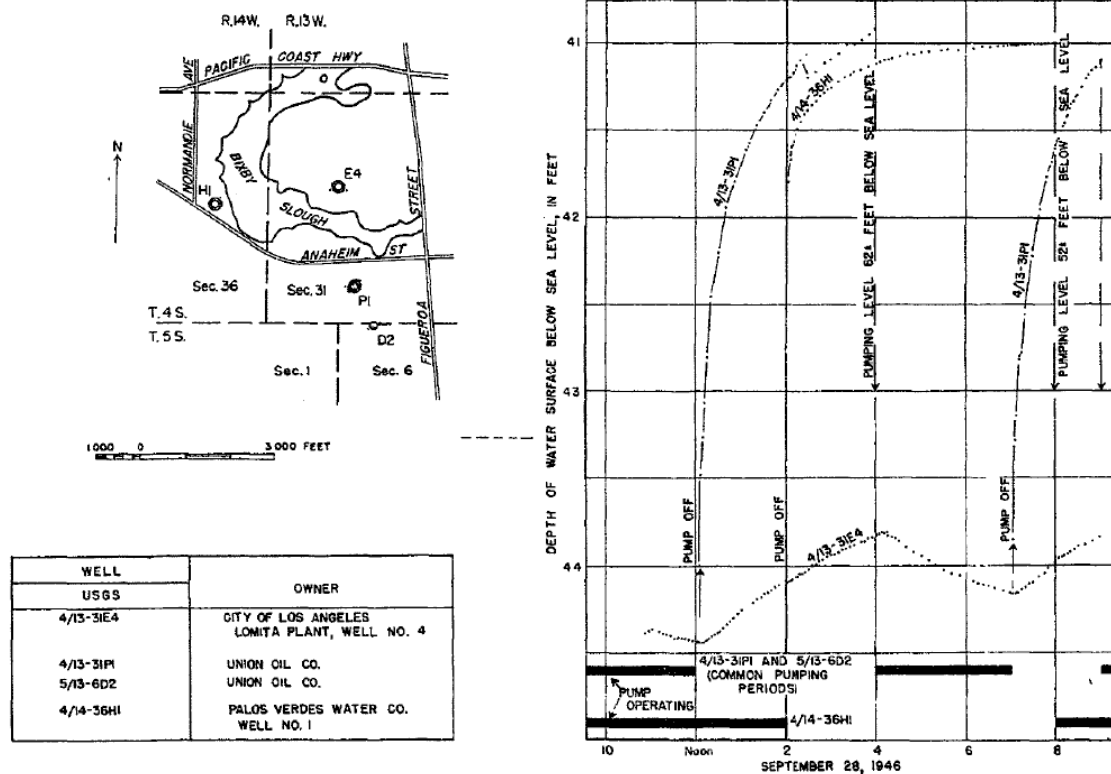

FIGURE 8.—Map of wells, and graph showing results of pumping tests to determine presence or absence of barrier features near Bixby Slough.

about 380 ppm of chloride and about 1,000 ppm of dissolved solids. On the other hand, the water withdrawn from the wells in 4/13-31E north of Anaheim Street, has ranged from 42 to 108 ppm of chloride and from 350 to 500 ppm of dissolved solids.

On September 28, 1946, the pumps at the Lomita plant of the city of Los Angeles were idle and had been shut down for several days. The wells of the Union Oil Co. had been pumped continuously for several months before the test, and the wells of the Palos Verdes Water Co. had been pumped intermittently during previous days. During the day, wells 4/13-31P1 and 5/13-6D2 (Union Oil Co.) and well 4/14-36H1 (Palos Verdes Water Co., well 1) were pumped intermittently on an alternating schedule (fig. 8), and water-level measurements were made by the Geological Survey at about 10-minute intervals from 10:00 a. m. to 9:00 p. m. at wells 4/13-31E4, 4/13-31P1, and 4/14-36H1. The fluctuation of water level in these wells is shown on figure 8. During the periods of pump operation as shown, the average joint discharge from the Union Oil Co. wells was about 2,150 gpm, and the discharge from well 4/14-36H1 was estimated by the operator as 1,230 gpm.

Between 12:10 and 4:10 p. m., the water level in well 31E4 recovered along a uniform curve as a result of the shutdown of the pumps in the Union Oil Co. wells from noon to 4:00 p. m. From 4:10 to 7:10 p. m., the water level in well 31E4 declined concurrently with pumping of the Union Oil Co. wells. There is no hydraulic barrier between the Union Oil Co. wells and well 31E4 at the Lomita plant of the city of Los Angeles. On the other hand, the recovering water levels in wells 31E4 and 31P1 did not show any response to the shutdown of the pump in well 4/14-36H1 (Palos Verdes Water Co., well 1) at 2:00 p. m., nor to the starting of the pump again at 8:00 p. m. Also, the recovering level in well 36H1 was not affected by the starting of the pumps in wells 4/13-31P1 and 5/13-6D2 of the Union Oil Co. at 4:00 p. m. Thus, there appears to be a substantial hydraulic barrier somewhere between well 36H1 on the west and wells 4/13-31E4, 31P1, and 5/13-6D2 on the east. The location and direction of this barrier are not known but it is inferred to be a cemented fault zone, because the Silverado water-bearing zone is known to be continuous, highly permeable, and about 700 feet thick between wells 4/13-31E4 and 4/14-36H1. If this barrier should extend northward from the Palos Verdes Hills into the west basin, it would have some effect on local circulation of ground water; but so far as known, it does not separate any of these wells from the main body of ground water in the west basin.



**REPLENISHMENT TO THE WEST BASIN**

**SOURCES AND GENERAL FEATURES**

**EARLY CONDITIONS**

Under the early conditions of ground-water development, replenishment to the water-bearing deposits of the west basin tapped by wells occurred in four ways. In probable relative order of importance they were as follows:

1. By underflow across the Newport-Inglewood uplift (the inland boundary of the west basin) through the deposits of Recent and of Pleistocene age.
2. By direct infiltration from the land surface of (a) water from rainfall, and (b) return water from irrigation, from cesspools, and by leakage from distribution systems.
3. By infiltration of local runoff water from the hills bordering the west basin, including the Santa Monica Mountains and the Santa Monica plain to the north, the hills of the Newport-Inglewood uplift (especially the Baldwin Hills) to the northeast, and the Palos Verdes Hills to the south.
4. By seepage within the west basin from the channels of the Los Angeles River to the south, and from Ballona Creek and its tributaries to the north.

**CONDITIONS DEVELOPED BY WATER-LEVEL DECLINE**

**OCEAN-WATER REPLENISHMENT**

During the period of ground-water use, the draft has become large and levels have been drawn down to sea level and below. As a result, in the twenties ocean water began to invade the water-bearing zones along the coast and became a source of recharge. Because of the accelerated decline of water levels in recent years this condition has become critical.

**WATER RELEASED BY COMPACTION**

Because of the drawdown of water level, water has been withdrawn from storage in the water-table reach, and some water has been derived by compaction of the aquifers and of the surrounding and enclosing fine-grained, relatively impervious sediments. The latter has been called "water of compaction" by Tolman (1937, p. 142-143, 470-472). The quantity so yielded doubtless has been largest in recent years and in areas of greatest drawdown of the pressure head, such as Dominguez Gap.

In certain other areas in California, large quantities of water have been derived by compaction of sediments resulting from regional drawdown of the pressure level. For example, in the Livermore Valley, Alameda County, Calif., Smith (1934; Tolman, 1937, p. 495-498) has estimated from a careful ground-water inventory that some 15,860 acre-feet of water was supplied by compaction of the alluvial materials during a low-water-level period from 1925 to 1930—an

average rate of about 3,200 acre-feet per year, as compared to an average yearly pumping draft of about 12,500 acre-feet. However, the amount of land-surface subsidence was not known, and the volume of compaction could not be determined.

In the Santa Clara Valley of Santa Clara County, Calif., Tolman and Poland (1940, p. 23-35) found that water of compaction, as measured by subsidence of the land surface and inferred equivalent reduction of pore space, was about 230,000 acre-feet from 1919 into 1937. Subsidence developed over an area of about 200 square miles as a result of an average water-level lowering of 100 feet in the 20 years from 1915 to 1935. The maximum subsidence, about 5.5 feet, was at San Jose. Insofar as water was derived from compaction of silt and clay bodies (aquicludes) within or enclosing the aquifers, it represented a nonreplaceable contribution to the usable ground-water supply.

In the west basin no such substantial subsidence of land surface has occurred as a result of ground-water withdrawal. In the vicinity of Terminal Island, near the crest of the Wilmington oil field, the land surface subsided as much as 7 feet between 1928 and 1947.<sup>9</sup> This subsidence was attributed by Gilluly, Johnson, and Grant (1945, also see Gilluly and Grant, 1949) as due almost wholly to the pressure decline and resulting compaction of the oil-bearing sands of Miocene and lower Pliocene age in the Wilmington oil field (which was caused by the removal of oil and gas beginning about 1937). In a recent report, Harris and Harlow (1947, p. 1197-1218) have concluded that the subsidence resulting from the pressure decline has occurred chiefly in the shale and siltstone associated with the oil sands. The publication of these two conflicting concepts on the mechanics of land subsidence emphasizes the need for careful research to resolve the relatively unexplored question of whether subsidence of the land surface associated with the withdrawal of large quantities of fluid is caused primarily by compaction of the permeable reservoir beds or of the relatively impermeable but porous silt, clay, and shale members which are interbedded with or confine the permeable beds, and which, in effect, are a part of the reservoir system.

A large range in the proportion of compaction of coarse-grained permeable deposits to that of fine-grained, relatively impermeable deposits probably will be found, as more examples of land subsidence associated with withdrawal of fluids or gases are studied in detail. The compressibility of each deposit must be in part a function of the physical character; for the fine-grained deposits the rate of com-

<sup>9</sup> Since the present report was released to the open file (1948), the maximum subsidence in the Wilmington area has increased to 22 feet (1955).

paction will also be a function of permeability which determines the rate at which pressure differentials can be equalized—that is, the rate at which fluid can escape from the fine-grained deposits to the more permeable reservoir rocks and permit compaction of the former.

Also in the vicinity of Terminal Island, a land subsidence of as much as half a foot occurred in 1941, concurrently with the dewatering for construction of the large graving dock at the Naval Operating Base on Terminal Island. A brief description of this dewatering operation, its effect on water levels in nearby wells, and the local subsidence of land surface has been given by Grant (1944, p. 149-154).

As summarized elsewhere (Poland, 1959), this dewatering at Terminal Island was carried out by turbine pumps in 36 gravel-envelope wells which tapped the Gaspur water-bearing zone. The dewatering was started on June 27, 1941, and reached a maximum during August, when the average rate of withdrawal was about 35,000 gpm. Pumping operations ceased on April 4, 1942, after the removal of about 26,000 acre-feet of water from the Gaspur zone in 9 months, or slightly more water than was pumped concurrently from this same zone by all water wells from Terminal Island to Whittier Narrows. The lowering of the piezometric level for the Gaspur water-bearing zone was as great as 35 feet in well 5/13-3L1 (Southern California Edison Co., well 4), and 15 feet in well 4/13-35M1, respectively 0.5 mile and 1.7 miles north of the center of pumping at the graving dock. The maximum recorded subsidence was at bench mark 43, at the southwest corner of the Southern California Edison Co. property and 1,650 feet from the center of the graving dock. Records taken by this company indicate that subsidence of bench mark 43 was 0.495 foot relative to bench mark 18, which is about 3,500 feet from the center of the graving dock. As described by Gilluly and Grant (1949, p. 497), substantial recovery of bench-mark altitudes coincided with recovery of water level in observation wells, during the reduced pumping rates of the latter part of the dewatering operation and immediately after cessation of pumping. The recovery of bench-mark altitudes ranged from 14 to 78 percent, with an average recovery of about 42 percent. From these facts, it was concluded by Gilluly and Grant that one-half or more of this subsidence due to the drawdown of the piezometric level of the Gaspur zone was attributable to mineral-grain rearrangement, and the remainder was due to elastic compression. It is of interest to note that the bench marks that underwent the largest subsidence had the smallest percentage of recovery of altitude.

At the center of the greatest drawdown of the pressure level of the Silverado zone within the west basin—at Carson and Alameda Streets in Dominguez Gap—the subsidence of land surface from about the

end of 1933 to 1944-46 was 0.354 foot, according to first-order leveling by the U. S. Coast and Geodetic Survey.<sup>10</sup>

Three miles to the south, on the right-of-way of the Southern Pacific Railroad, about 0.6 mile northeast of the Anaheim Street crossing, bench mark G 33-67 subsided 1.316 feet between 1914 and 1944-46. Of this subsidence, 0.942 foot has occurred since December 1931, and 0.528 foot since July 1941. This bench mark is within the productive limits of the Wilmington oil field and the greater part of the subsidence is believed to have been caused by the compaction which accompanied the withdrawal of oil and gas from that field.

Although the land surface has subsided several tenths of a foot throughout much of the southern part of the west basin, it is not known how much of this subsidence is due to compaction of sediments accompanying the decline of pressure head in the Silverado water-bearing zone. It may have been partly because of tectonic adjustments and partly because of pressure decline in the saline water sands at much greater depth which are hydraulically connected with the producing oil sands of the Wilmington and other oil fields. Accordingly, a direct estimate of subsidence due to compaction of sediments accompanying the decline of pressure head in the Silverado zone has not been attempted in this investigation. However, the quantity of water made available by such compaction of sediments has been estimated on page 151, by use of the empirical storage coefficient determined from the lowering of pressure head in well 4/14-13F1 due to the pumping of the wells at the Lomita plant of the city of Los Angeles (p. 133).

With fully effective confinement, water is yielded from storage only in proportion to the compaction of the water-bearing system (and expansion of the fluid) in response to pressure drop; therefore, it follows that in such cases the storage coefficient must be a measure of the compressibility of the system, and of the land-surface subsidence that will occur with each foot of sustained drawdown of the regional pressure level. However, in the ground-water basins of southwestern United States the water-bearing deposits consist almost entirely of valley fill (Meinzer, 1923, p. 291-303), and confining beds, although abundant, commonly are not extensive. Thus, with prolonged and substantial withdrawal of water, conditions of fully effective confinement are rarely found, and most of the water commonly is withdrawn from storage in the unconfined reaches of the basins by draining of the pore spaces. Only near the coast, where relatively impermeable beds associated with marine deposition are extensive, and in valleys such

<sup>10</sup> Bench mark D-167—At Dolores, at the southeast corner of the intersection of Alameda and Carson Streets, on the Dominguez Water Corp. property, at the pumping-plant building, in the face of the west wall.

as the San Joaquin, where the deeper water wells partly tap aquifers interbedded with fine-grained lacustrine deposits, would reasonably effective confining systems be found. When considered in relation to time intervals of as much as a few years, and possibly even several tens of years, conditions of fully effective confinement presumably are encountered only in the great artesian basins in which the aquifers have been deposited in interior seas. Probably the Dakota sandstone and the overlying plastic shales form the outstanding example of such a basin (Meinzer and Hard, 1925, p. 73-96; Darton, 1896).

Within the west basin, the area of greatest overdraft and of most serious saline contamination is the Torrance-Inglewood subarea. For these reasons, this subarea now (1948) is involved in a pending adjudication of water rights. Thus, the following appraisals of replenishment concern first the magnitude of replenishment to the Torrance-Inglewood subarea and second the replenishment to the smaller subbasins in the Culver City subarea.

#### REPLENISHMENT TO THE TORRANCE-INGLEWOOD SUBAREA

##### MAGNITUDE OF REPLENISHMENT IN 1903-4

The average rate of replenishment to the west basin in 1903-4 is believed to have been nearly equivalent to the natural and artificial discharge of that time. Such discharge occurred almost wholly by underflow to the ocean through the undersea extensions of the aquifers of Pleistocene and Recent age and by withdrawal through wells. The water levels were too far below the land surface to afford appreciable opportunity for evapotranspiration losses.

For the Torrance-Inglewood subarea an estimate of the natural discharge to the ocean in 1903-4 can be made by summing up (1) the discharge from the San Pedro formation (Silverado water-bearing zone and correlative aquifers) along the west coast from Playa del Rey to the Palos Verdes Hills, and along the south coast from the Palos Verdes Hills to the Los Angeles River, and (2) the discharge from the Gaspur water-bearing zone to San Pedro Bay. For the Silverado zone, the cross section along the coast is known with reasonable accuracy (pl. 3C), but the hydraulic gradient during 1903-4 at the coast cannot be accurately determined. Although water-level contours for the Silverado zone in 1903-4 have been reconstructed from data of Mendenhall (pl. 9 and p. 90), few of the wells in which water-level measurements were made near San Pedro Bay and from Manhattan Beach northward to Playa del Rey tapped the Silverado zone. The permeability of the Silverado zone was determined from pumping tests near Torrance and near Bixby Slough, but it was not determined along the coast. Yield factors for wells near the west coast compared to yield factors for wells between Long

Beach and Torrance (table 5)—where the permeability has been determined as about 2,000 gpm per square foot (p. 54)—suggest a proportion of about 2 to 3, or a permeability of about 1,300 gpm per square foot for the coastal reach from Palos Verdes Hills to Playa del Rey. The following paragraphs sum up the several increments of natural discharge:

1. For the reach from the Palos Verdes Hills to Hermosa Beach, the discharge to the ocean as of 1903-4 has been estimated as about 11 cfs, or about 8,000 acre-feet a year (p. 92).

2. In the same way and only as an approximation, the discharge to the ocean between Hermosa Beach and Playa del Rey can be estimated. The length of this reach is about 7 miles, the average thickness of the aquifer is about 125 feet (pl. 3C), the permeability is estimated as about 1,300 gpd per square foot, and the average hydraulic gradient at the coast in 1903-4 was at least 2 feet per mile. Thus, the discharge of that time (north of Hermosa Beach) is estimated to have been at least 2.3 mgd—about 3.5 cfs or about 2,500 acre-feet per year.

3. In regard to discharge from the Silverado water-bearing zone to San Pedro Bay, electric-log data for oil wells on Terminal Island indicate that the aquifers of the Silverado zone along that reach have an average thickness of about 250 feet. From the Los Angeles River west to the non-water-bearing rocks of the Palos Verdes Hills the width of the escape area is about 4 miles. Thus, the effective cross section is about 1,000 foot-miles. The coefficient of permeability for the Silverado zone in this area is not known, but it is probably somewhat lower than that in the Torrance area, where it was determined to be about 2,000 gpd per square foot (p. 54), and near Bixby Slough where it is about 1,400 gpd per square foot. If the permeability beneath Terminal Island is assumed to be about 1,000 gpd per square foot and if the hydraulic gradient of 1903-4 is taken as 4 feet per mile (p. 91), then the oceanward discharge through the Silverado zone beneath Terminal Island can be calculated at about 4 mgd—about 6.2 cfs or approximately 4,500 acre-feet per year.

4. Underflow to San Pedro Bay from the Gaspur water-bearing zone of Recent age is estimated to have been about 2.8 cfs, or about 2,000 acre-feet per year. These figures are based on the assumption that conditions at the coast were as follows: width of water-bearing zone, 2 miles (pl. 8); thickness, 60 feet—or an area of 120 foot-miles; hydraulic gradient, about 5 feet per mile (Mendenhall, 1905a, pl. 4); and an estimated permeability of 3,000 gpd per square foot (see p. 31).

In summation, the estimated yearly discharge to the ocean in 1903-4 from the aquifers beneath the Torrance-Inglewood subarea was about 21 cfs or 15,000 acre-feet from the Silverado water-bearing zone and was about 2.8 cfs or 2,000 acre-feet from the Gaspur water-bearing zone. Thus, the estimated total subsea escape was about 24 cfs or about 17,000 acre-feet per year. When this figure is added to the artificial discharge by pumping—which has been estimated at about 10,000 acre-feet per year during 1903-4 (p. 99)—the suggested over-all discharge was about 27,000 acre-feet per year, and the replenishment was comparable to that figure.

The rainfall record for Los Angeles (table 2) indicates that the 11 years ending with 1903-4 included only 4 years of normal or slightly above normal rainfall. With respect to the 68-year average rainfall of 15.53 inches, at the end of the year 1892-93 there was a cumulated surplus of 43.34 inches of rainfall. By the end of 1903-4 there was a cumulated deficiency of 3.79 inches, indicating an 11-year deficiency of 47.13 inches. The 3 years beginning with 1897-98 were the driest on record. Thus, runoff to the streams and recharge to the main coastal basin must have been continuously deficient during the 11-year period. Largely because of this deficiency, ground-water levels in the intake area near Whittier declined about 14 feet in this period and those near Anaheim declined about 40 feet (Poland, 1958). Also, the pressure level at the Bouton wells 2.5 miles north of Signal Hill and only 2 miles from the west basin boundary, declined about 80 feet in the same period. The decline of pressure head in the Bouton wells was far more than the average for the main coastal basin in Los Angeles County, however. The decline of artesian pressure along the northeast flank of the Newport-Inglewood uplift between Compton and Manchester Boulevard is known to have averaged about 30 feet from the initial historic level to 1904 (Mendenhall, 1905b, pl. 5).

The recharge to the west basin must have been affected in two ways by this deficiency of rainfall. First, there must have been little if any direct penetration of rainwater from the land surface in this period; certainly there was essentially none except in the 4 wettest years. Second, the replenishment by underflow across the Newport-Inglewood uplift must have diminished substantially in the 11-year period, because the pressure levels on the inland side of the barrier faults fell about 30 feet. Draft from the Torrance-Inglewood subarea was not large at that time and it appears doubtful that pressure levels in that subarea of the west basin could have declined in any such amount. Accordingly, the pressure differential across the barrier faults is inferred to have been greatly reduced by the decline in pressure level in the main basin; thus recharge to the Torrance-Inglewood subarea probably was considerably less in 1903-4 than in the eighties. It is believed that under native conditions of average rainfall the recharge to the Torrance-Inglewood subarea was 30,000 to 40,000 acre-feet per year.

#### MAGNITUDE OF REPLENISHMENT IN 1933-41

The replenishment to an underground basin may be estimated by measurement or calculation of the rate of inflow (intake methods) or the rate of discharge (discharge methods), or by determining changes in ground-water storage. Methods that have been applied to deter-

mine intake and discharge from ground-water reservoirs have been summarized by Meinzer (1932, p. 99-144).

For the west basin, the direct appraisal of the several elements of replenishment would be very tedious, and estimates of rain-water penetration, irrigation return water, and underflow (subsurface recharge) are subject to substantial error unless the basic data are sufficient to furnish reasonable control over the variable factors in the respective equations. Such is not the case at the present time. However, it is understood by the writer that the California Division of Water Resources, as referee in the pending adjudication of water rights, is planning to make a careful estimate of the several elements responsible for replenishment to the basin (California Division of Water Resources 1952).<sup>11</sup>

#### ESTIMATE BY RELATING PUMPAGE AND CHANGE IN STORAGE

For the purposes of this investigation, the elements of greatest interest are the over-all replenishment, the sea-water contribution, and the underflow across the Newport-Inglewood uplift. It can be assumed that, for years of average rainfall, the contribution by infiltration of water from rainfall and runoff from the land surface will be nearly constant from year to year. The residential and industrial areas are expanding rapidly and the agricultural area is decreasing, but the joint contribution by return water from irrigation of crops and lawns probably will not change appreciably as agricultural lands become residential districts.

The average gross replenishment can be determined most simply by selecting a period of years in which the cumulated rainfall did not markedly digress from the cumulated average, and in which the position of the water level was about equal at the beginning and the end of the period—that is, a period of little or no storage change. If the pumpage is known (or closely estimated) and if the storage change is estimated by the use of the specific yield and storage coefficients, the replenishment can be calculated. If there is no seaward discharge and no change in storage within the period, the gross replenishment is equal to the pumpage.

For the Torrance-Inglewood subarea of the west basin—the area included in the plaintiff's complaint for adjudication of water rights<sup>12</sup>—a relatively small amount of storage change occurred from the spring high-water level of 1933 to the spring high-water level of 1941 (pls. 9 and 11). Accordingly, this period of 8 years has been

<sup>11</sup> Since this report was released to the open file (1948), the California Division of Water Resources has completed its investigation as referee.

<sup>12</sup> California Water Service Co. and others v. City of Compton and others, Action No. 506,806 in the Superior Court for Los Angeles County, Calif., Oct. 1945.



selected for appraisal of the average replenishment to this area before the accelerated draft and decline of water levels in the war years 1942-45.

The average yearly rainfall at Los Angeles in the years from 1933 into 1941 was greater than normal. However, 1940-41 was the only year of greatly excessive rainfall (table 2). With respect to the average rainfall for the 68 years from 1877-78 through 1944-45, as shown in table 2, the average rainfall in the years 1932-33 through 1939-40 was 1.76 inches above normal, and the cumulated surplus for the 8 years was 14.04 inches. For the 9 years from 1932-33 through 1940-41 the yearly average increased to 3.47 inches above normal, and the cumulated surplus was 31.27 inches. Thus, it might be expected that inclusion of the year 1940-41 would yield a nonrepresentative figure for storage change and replenishment. However, most of the water withdrawn from the Torrance-Inglewood subarea is taken from the Silverado water-bearing zone, which is confined by relatively impermeable beds through most of the area. Therefore, it is doubtful that the rainwater penetration of the winter 1940-41 could have had an appreciable effect on the water levels of the Silverado zone or even on the water levels in the shallower "200-foot sand" by April 1941. Examination of the hydrographs introduced on figures 4 and 5 and plates 13 and 14 substantiates this general conclusion. Therefore, it is considered that the period selected is reasonably representative but that rainwater penetration in the 8 years was slightly above average.

The rise or fall of water level in the Silverado water-bearing zone from March 1933 (pl. 9) to April 1941 (pl. 11) is shown by lines of equal change (long dashes) on plate 10; the rise or fall for the "200-foot sand" in this 8-year period also is shown (short dashes). As discussed on pages 87-88, a water table occurs in the Silverado water-bearing zone only in the Redondo Beach area (pl. 10); another water table occurs in the correlative main water-bearing zone of the San Pedro formation in the vicinity of Playa del Rey. It will be noted from the lines of equal change on plate 10 that: (1) the storage change in the water-table reach of the Silverado zone near Redondo Beach did not exceed 5 feet; and (2) the storage change in the water-table reach of the main water-bearing zone near Playa del Rey did not exceed 6 feet. The maximum change (except for the local fall of 20 feet east of Inglewood between the Potrero and Inglewood faults) in the Torrance-Inglewood subarea, east of Hawthorne in the pressure area, was about 16 feet. Inland beyond the west basin boundary, the maximum fall was in excess of 30 feet.

TABLE 13.—Estimated storage change in the Torrance-Inglewood subarea, from March 1933 to April 1941, for the Silverado water-bearing zone and correlative aquifers in the San Pedro formation

| Township (S.) and range (W.)                                                  | Area (square miles) | Rise (+) or fall (-) (feet) | Change in volume    |           | Storage change (acre-feet of water) |
|-------------------------------------------------------------------------------|---------------------|-----------------------------|---------------------|-----------|-------------------------------------|
|                                                                               |                     |                             | Square miles × feet | Acre-feet |                                     |
| <b>Silverado water-bearing zone, water-table area near Redondo Beach</b>      |                     |                             |                     |           |                                     |
| -----                                                                         | 2.91                | -1                          | -2.91               | -1,862    | -----                               |
| -----                                                                         | 11.94               | -3                          | -35.82              | -22,925   | -----                               |
| -----                                                                         | .72                 | -5                          | -3.60               | -2,304    | -----                               |
| -----                                                                         | 1.38                | +1                          | +1.38               | +883      | -----                               |
| -----                                                                         | 1.05                | +3                          | +3.15               | +2,016    | -----                               |
| -----                                                                         | .17                 | +5                          | +.85                | +544      | -----                               |
|                                                                               | 18.17               | -----                       | -36.95              | -23,648   | <sup>1</sup> -4,730                 |
| <b>Main aquifer, San Pedro formation, water-table area near Playa del Rey</b> |                     |                             |                     |           |                                     |
| -----                                                                         | 1.42                | -1                          | -1.42               | -909      | -----                               |
| -----                                                                         | 1.11                | -3                          | -3.33               | -2,131    | -----                               |
| -----                                                                         | .39                 | -5                          | -1.95               | -1,248    | -----                               |
| -----                                                                         | 2.00                | +1                          | +2.00               | +1,280    | -----                               |
|                                                                               | 4.92                | -----                       | -4.70               | -3,008    | <sup>1</sup> -600                   |
| <b>Silverado water-bearing zone, confined area</b>                            |                     |                             |                     |           |                                     |
| 2/14                                                                          | 7                   | -11.6                       | -81                 | -----     | -----                               |
| 2/15                                                                          | 1                   | -5                          | -5                  | -----     | -----                               |
| 3/13                                                                          | 8                   | -4.4                        | -35                 | -----     | -----                               |
| 3/14                                                                          | 33.5                | +8.5                        | -285                | -----     | -----                               |
| 3/15                                                                          | 5                   | -2.2                        | -11                 | -----     | -----                               |
| 4/13                                                                          | 32                  | + .8                        | +25                 | -----     | -----                               |
| 4/14                                                                          | 7.5                 | 0                           | 0                   | -----     | -----                               |
|                                                                               | 94                  | -----                       | -392                | -250,880  | <sup>2</sup> -300                   |

<sup>1</sup> Total change in volume (acre-feet) multiplied by 0.20 (specific yield).

<sup>2</sup> Storage coefficient assumed to be 0.0012 throughout the pressure area.

The storage change in the Silverado water-bearing zone was determined in the following manner:

1. The working copy of plate 10, at a scale of 1:48,000 was superimposed over a map sectionized in the manner of plate 2, each main grid unit representing 1 square mile. For the two water-table areas, a grid subdivided in hundredths of a square mile was utilized to determine the part of each section falling between two lines of equal change. For the larger pressure area, the average change of water level in feet was estimated for each square mile. For each territory the area in square miles lying between lines of equal water-level change (0-2, 2-4, and 4-6) was summed up separately. Cumulative areas so obtained were multiplied by the odd-foot value between the two boundary lines (the average change for the area between the 2- and 4-foot lines was assumed to be 3 feet), giving a volume for storage change in square miles × feet. By summing up all such volumetric elements for each area, the total volume change was obtained for that area.

152 GEOLOGY, HYDROLOGY, TORRANCE-SANTA MONICA AREA

2. The specific yield for the two water-table areas was assumed to be 20 percent (in accordance with estimates made by Eckis from samples collected in the field and tested in the laboratory) (1934, pl. E). The storage coefficient of 0.0012—obtained from the drawdown of water level in well 4/14-13F1 due to pumping of the Lomita plant wells (p. 133)—was applied to the main pressure area. Table 13 presents a summary of water-level changes, volumes dewatered or saturated (or of pressure-level change), and water released from storage.

The storage change has been computed for the "200-foot sand" in the same manner. Contours of the water level in this aquifer were not constructed for the beginning and end of the period of appraisal. Instead, the changes in position of the water level in the period for individual wells were plotted on the working copy of plate 10 and the lines of equal change were drawn from these data. Table 14 summarizes the results of the computation. About one-fourth of the pertinent well logs show water-table conditions at current water levels in the upper Pleistocene deposits ("200-foot sand" and other deposits); therefore, the over-all specific yield was assumed to be about 5 percent.

TABLE 14.—Estimated storage change in the Torrance-Inglewood subarea, from March 1933 to April 1941, for the "200-foot sand" and correlative deposits of upper Pleistocene age

| Area (sq mi) | Rise (+) or fall (-)<br>(feet) | Change in volume    |           | Storage change<br>(acre-feet of water) |
|--------------|--------------------------------|---------------------|-----------|----------------------------------------|
|              |                                | Square miles × feet | Acro-feet |                                        |
| 16.93        | -3                             | -50.79              | -32,505   | -----                                  |
| 19.70        | -5                             | -98.50              | -63,040   | -----                                  |
| 10.90        | -7                             | -76.30              | -48,830   | -----                                  |
| 8.24         | -9                             | -74.16              | -47,460   | -----                                  |
| 55.77        | -----                          | -299.75             | -191,835  | <sup>1</sup> -9,600                    |

<sup>1</sup> Total change in volume (acre-feet) multiplied by 0.05 (specific yield).

The estimated storage change within the Silverado zone in the 8-year period (table 13) is 5,600 acre-feet of which 5,300 acre-feet occurred in the water-table areas. The estimated storage change in the unnamed upper Pleistocene deposits (table 14) is 9,600 acre-feet. Thus, the over-all withdrawal from storage in the 8 years is estimated to have been 15,200 acre-feet, or an average rate of about 2,000 acre-feet per year. Changes in storage in the shallow unconfined body and in the 400-foot gravel probably were inconsequential during this period.

The total withdrawal from the Torrance-Inglewood subarea in the 8 years from 1933 through 1940 (table 8) was 383,100 acre-feet; the average rate of withdrawal was about 47,900 acre-feet per year. There was essentially no natural discharge during this period, therefore, the gross replenishment is equal to the withdrawal less the change in

storage—that is, 383,100 less 15,200 or 367,900 acre-feet. Thus, the average yearly gross replenishment is estimated to have been about 46,000 acre-feet.

#### CONTRIBUTION FROM THE OCEAN

With the extensive drawdown of water levels to and below sea level, saline waters have invaded the Torrance-Inglewood subarea along the full reach from Playa del Rey to the Palos Verdes Hills. Also, along the south shore from the Palos Verdes Hills to the Los Angeles River channel, saline waters probably have moved northward beyond Terminal Island toward centers of pumping. The water in the Silverado zone beneath Terminal Island is inferred to have been of inferior quality under native conditions (Piper, Garrett, and others, 1953, p. 197). To date, these inferior waters have not advanced sufficiently far northward to reach any actively pumped well fields. As shown by the distribution of withdrawals on plate 12, the first major well fields to receive such inferior waters presumably would be that of the Union Oil Co. in Wilmington (pl. 12, no. 23) and that of the Texas Co. (pl. 12, no. 24) at the west edge of Dominguez Gap. Regardless of the quality of the ground water in the Silverado zone beneath Terminal Island, there must have been a substantial contribution of water to the west basin from the subsea reach south of Terminal Island in response to the landward gradients that have existed since the early thirties. This contribution is not being replaced by water of good quality, and probably it is being followed landward by saline waters, either ocean water entering the outcrop of the Silverado zone beneath San Pedro Bay, or connate saline waters contributed from within the subsea ground-water system, or both.

Ocean water advanced inland in the Gaspur water-bearing zone in the thirties (see p. 259, also pl. 16); the extent of that inland advance has been shown in an earlier report (Piper, Garrett, and others, 1953, pl. 17).

The over-all contribution from the ocean or from the seaward extensions of the water-bearing zones of the Torrance-Inglewood subarea from 1933 to 1941 is estimated in following paragraphs.

The extent of encroachment of saline waters for the reach along the west coast from Playa del Rey to the Palos Verdes Hills is shown on plate 16. The contribution from the ocean can be computed if the assumption is made that the rate of advance of the saline front is a direct measure of the rate of landward inflow of salt water to the water-bearing deposits.

From the appraisal of the rates of saline encroachment as suggested by the advance of the saline front from 1931 to 1946 (pl. 16), and with consideration to the effective hydraulic gradients, it is concluded

(p. 251 to 253) that the average yearly rate of advance of the saline front from Playa del Rey to El Segundo from 1931 to 1941 did not exceed 40 feet, from El Segundo to Hermosa Beach it was about 115 feet, and from Hermosa Beach to the Palos Verdes Hills it was about 90 feet. The effective porosity of the Silverado water-bearing zone and correlative water-bearing deposits along this full reach is estimated to be about 20 percent. The product of the cross-sectional area of water-bearing materials, the average yearly advance, and the effective porosity may be considered to be a measure of the contribution seaward from the front.

The cross-sectional area (pl. 3C) for the reach from Hermosa Beach to the Palos Verdes Hills is about 3.5 miles long by 400 feet thick. If the average advance of the front (pl. 16) was 90 feet per year through material with an effective porosity of 20 percent, the quantity of water required to fill the block 3.5 miles long by 400 feet thick by 90 feet wide would be about 3,100 acre-feet. In the same way, the yearly displacement for the reach from Hermosa Beach to Playa del Rey is estimated at about 2,500 acre-feet.

By this method, the average annual contribution to the ground water in the area coastward from the saline front in the reach from Playa del Rey to the Palos Verdes Hills for the years from 1931 to 1941 is estimated to be about 5,600 acre-feet.

By another method, the contribution along this reach can be computed as the product of: (1) the cross-sectional area of permeable material; (2) an estimated permeability of 1,300 gpd per square foot (p. 147); and (3) the average hydraulic gradient. For the reach from Hermosa Beach to the Palos Verdes Hills, where the average landward gradient of the thirties was about 3.5 feet per mile, the contribution so computed is 7,100 acre-feet per year. If the contribution in the reach from Hermosa Beach to El Segundo is computed assuming a permeability of 1,300, a cross-sectional area 4.5 miles long and 150 feet thick, and an equivalent hydraulic gradient of 3.5 feet per mile; and if the small contribution from El Segundo to Playa del Rey is estimated from the rate of saline encroachment, as above, the over-all contribution along the west coast is about 10,800 acre-feet per year.

If the quantities derived by these two independent methods are assumed to indicate the general limits of such a contribution along the west coast in the thirties, the suggested mean is about 8,000 acre-feet per year. Most of this contribution must have been ocean water, but it also included water that descended from the land surface to the water table, in the areas coastward from the saline front, south of Hermosa Beach and north of El Segundo. In the thirties, these two areas included about 3,000 acres, and the average annual contribution of water from the land surface in this dune-sand area may have been

as much as 1,000 acre-feet. If these figures are correct, the ocean-water contribution is estimated to be about 7,000 acre-feet per year.

For the south coast facing San Pedro Bay, the landward movement of water in the Silverado water-bearing zone in the thirties can be estimated in the same manner as the coastward discharge of 1903-4 (p. 147). It is inferred that the Silverado zone or correlative deposits crop out on the ocean floor from 8 to 9 miles southwest of Terminal Island.<sup>13</sup> The average depth of the piezometric level at Terminal Island from 1933 to 1941 was about 30 feet below sea level. Thus, the average inland gradient of those years is inferred to have been about 4 feet to the mile—about equal to the coastward gradient of 1903-4. Therefore, the annual contribution of water moving northward in the Silverado zone from beneath San Pedro Bay in the thirties is estimated to have been about 4,500 acre-feet per year.

The landward movement of salt water in the Gaspar water-bearing zone is known to have underrun about 300 acres from 1931 into 1943 (Piper, Garrett, and others, 1953, pl. 17 and p. 178). The thickness of the Gaspar water-bearing zone is about 60 feet and the effective porosity is about 25 percent. The landward encroachment of the thirties thus was approximately 400 acre-feet per year.

In summation, the average yearly contribution of water to the Torrance-Inglewood subarea from 1933 to 1941 from the ocean or from the subsea extensions of the aquifers is estimated to have been about 12,000 acre-feet per year. Thus, within the limitations of the assumptions made here the average net replenishment of fresh water to the Torrance-Inglewood subarea in these years is 46,000 acre-feet less 12,000 acre-feet, or about 34,000 acre-feet per year.

#### UNDERFLOW ACROSS THE NEWPORT-INGLEWOOD UPLIFT

Under native conditions of high-water level, the quantity of underflow passing across the Newport-Inglewood uplift from the main coastal basin to the Torrance-Inglewood subarea along the crestal reach from Long Beach to the Baldwin Hills varied in accordance with the differential in the water levels across the fault barriers of the uplift as the one variable (the product of permeability and cross section was a constant). At the crest of the uplift the Silverado water-bearing zone and related deposits in the San Pedro formation then were fully saturated, and the upper Pleistocene water-bearing zones were fully saturated, except at the crests of Dominguez Hill and the Rosecrans Hills, and high on the flank of the Baldwin Hills.

In accordance with the drawdown of water level due to increased withdrawal from the main coastal basin, water levels along the crest of the uplift have declined from 100 to 150 feet below the initial levels

<sup>13</sup> U. S. Coast and Geod. Survey hydrologic chart 5143, Los Angeles harbor and vicinity, 1936.

and substantial dewatering of certain aquifers has occurred. For aquifers almost entirely dewatered along the crest of the uplift, the transmissibility of the saturated cross section has become the primary control on the quantity of water passing into the west basin, and the differentials at the barrier features have become secondary. For aquifers wholly dewatered along the crest, no water passes coastward beyond the crest, and the differentials along the barrier features have no meaning.

#### DEWATERING ALONG THE UPLIFT CREST

Plate 15 has been prepared for the purpose of appraising the magnitude of dewatering of the water-bearing beds along the crest of the Newport-Inglewood uplift from the Baldwin Hills to Long Beach. The position of the water-bearing beds (pl. 15) has been generalized from plate 3A, with slight modification between Manchester Avenue and Imperial Highway, in order to follow the land-surface and inferred subsurface crests. Plate 15B shows on an expanded scale, the pressure level and the local water table of the Silverado water-bearing zone and correlative aquifers along the alinement of the section for selected times from 1903-4 to 1945. A partial plot of the water levels of the eighties, inferred from data by Mendenhall, also is shown. The water-level profiles for 1904, 1933, 1941, and 1945 are taken from plates 9-12; the profile for 1930 is from a work map not included in the report. Although the water-level profiles are constructed from data for wells tapping the Silverado zone and correlative deposits, these profiles also can be used to appraise the general order of dewatering of the upper Pleistocene deposits. Part of the generalized position of the top of the Silverado zone has been plotted at the expanded scale of plate 15B in order to emphasize the extent of dewatering in this principal aquifer.

As shown by the profiles of plate 15, the upper Pleistocene water-bearing deposits (the "200-foot sand" and correlative deposits) have been extensively dewatered along the crest. On the other hand, the Silverado water-bearing zone and lower Pleistocene correlative deposits have been partly dewatered in the 6-mile reach between the Baldwin Hills and El Segundo Boulevard, but no dewatering has occurred in the 8-mile reach from El Segundo Boulevard to Los Cerritos (Long Beach). The extent of dewatering is summarized as follows:

1. The upper Pleistocene water-bearing deposits initially were fully saturated except at the crests of the Dominguez Hill and Rosecrans Hills and high on the south flank of the Baldwin Hills. By 1945 these deposits had been entirely dewatered along all the crestal reach northwest of El Segundo Boulevard, and had been dewatered nearly to sea level along the crestal reach of Dominguez Hill. Thus, in the early forties, the only segments of these deposits still saturated were: the 3-mile reach between El Segundo Boulevard and Artesia Street, along most

of the Avalon-Compton fault; and the 3-mile synclinal reach beneath and adjacent to Dominguez Gap. The water-bearing beds in the reach along the Avalon-Compton fault are only about 60 feet thick but they are highly permeable and are tapped by many wells; thus, these deposits are believed to transmit substantial underflow through the fault barrier. On the other hand, the water-bearing beds beneath Dominguez Gap, which are composed almost entirely of fine sand (pl. 3A), as much as 120 feet thick (well 4/13-2J1), are not tapped by many wells because they are not highly permeable, and their transmissibility is less than that of the thinner aquifers northwest of Dominguez Hill.

In terms of cross-sectional area, about 50 percent of the upper Pleistocene water-bearing deposits throughout the area shown on plate 15A have been dewatered by the drawdown of water level from native conditions to the levels of 1945. However, the reduction in transmissibility has been much more than 50 percent, because the permeable deposits which occur northwest of well 3/13-17E1 and including those at the Centinela Park well field of the city of Inglewood, have been wholly dewatered. Utilizing the generalized data of plate 15A, the calculated cross-sectional area of the initially saturated upper Pleistocene aquifers is 4.4 million square feet and by 1945 the dewatered area totaled 2.1 million square feet.

2. The Silverado water-bearing zone and correlative aquifers in the San Pedro formation of early Pleistocene age initially were fully saturated along all of the crestal reach from Los Cerritos (Long Beach) to the Baldwin Hills. In nearly all of the 8-mile reach southeast of El Segundo Boulevard, the top of the Silverado zone is more than 100 feet below sea level, and beneath Dominguez Gap is as much as 400 feet below sea level. However, between El Segundo Boulevard and the Baldwin Hills, the top of the Silverado zone and correlative deposits is several tens of feet above sea level on a large area. Thus, because of the decline of water level to near sea level, by 1945, extensive dewatering has occurred in the deposits in the 6-mile reach northwest of El Segundo Boulevard.

In terms of cross-sectional area, about 35 percent of the water-bearing beds of the San Pedro formation northwest of El Segundo Boulevard had been dewatered by 1945. Throughout the entire reach, only about 10 percent had been dewatered. However, in the 2-mile reach from near well 2/14-27J1 (city of Inglewood, well 16) southeast to the intersection of Century Boulevard and Western Avenue, the decline of water level by 1945 had dewatered about two-thirds of the thickness and only 30-50 feet of the Silverado zone remained saturated. No well data are available to determine whether the reduction in saturated cross section may have been partly compensated by a steepening of the hydraulic gradient. In any case, a drawdown of water levels to as much as 30 feet below sea level would essentially dewater the Silverado water-bearing zone in this reach and would prevent underflow to the west basin.

From the generalized data of plate 15, the calculated cross-sectional area of the Silverado water-bearing zone and correlative aquifers is 18 million square feet, of which about 12.8 million is south of El Segundo Boulevard and about 5.2 million is north; of the latter, about 2 million square feet had been dewatered by 1945. Thus, the saturated cross-sectional area of the lower Pleistocene aquifers, as compared with that of the upper Pleistocene aquifers, was about four times as great under initial conditions and about seven times as great in 1945.

#### CHANGE IN DIFFERENTIAL HEAD ACROSS THE BARRIER FEATURES

The average differentials in water level across the barrier features of the uplift between the Baldwin Hills and the southeast edge of



Dominguez Gap can be calculated approximately from water-level contour maps of the Silverado water-bearing zone by estimating average differential heads across measured segments of the barrier features and totaling these differentials, which are weighted in accord with the lengths of the respective segments. In this manner, average differentials in water level have been estimated for 1904, 1933, 1941, and 1945, from the data of plates 9 to 12. Results are summarized in table 15.

TABLE 15.—Average water-level differentials, in feet, across the barrier features of the Newport-Inglewood uplift between the Baldwin Hills and Long Beach, 1904-45

| Year                 | Baldwin Hills to El Segundo Boulevard (6 miles) | El Segundo Boulevard to Long Beach (8 miles) | Totaled average from Baldwin Hills to Long Beach (14 miles) |
|----------------------|-------------------------------------------------|----------------------------------------------|-------------------------------------------------------------|
| 1904.....            | 49                                              | 33                                           | 40                                                          |
| 1933 (March).....    | 29                                              | 37                                           | 34                                                          |
| 1941 (April).....    | 22                                              | 33                                           | 28                                                          |
| 1945 (November)..... | 32                                              | 40                                           | 36                                                          |

The water-level differentials have been summed up separately for the 6-mile reach northwest of El Segundo Boulevard and the 8-mile reach to the southeast. The former parallels the area of partial dewatering along the crest, and also is the one with the poorer control on water-level differentials, especially across the Potrero fault north of Century Boulevard; here, the amount of drawdown of water level in the several fault blocks between the Potrero and Inglewood faults is irregular and largely unknown.

Although the average differentials presented in table 15 are only approximate and their derivation has required a considerable amount of extrapolation, they suggest with respect to the Silverado water-bearing zone and correlative deposits that:

1. In 1904 the differential in water levels was about 50 percent greater northwest of El Segundo Boulevard than to the southeast.
2. By 1933 the differential northwest of El Segundo Boulevard had decreased about 40 percent and was less than the differential to the southeast, which had increased slightly.
3. The average differential was least in 1941 only 28 feet for the over-all 14-mile reach.
4. If the average head differential between 1933 and 1941 is assumed to be the average of those 2 years, then the head differential northwest of El Segundo Boulevard in that 8-year period (26 feet) was just about half of that in 1904, whereas southeast of El Segundo Boulevard it was slightly higher than in 1904 (35 feet). If the water transmitted across the barrier features is proportional to the differential in head, as seems reasonable, if the permeability of the water-bearing beds is considered uniform along the full reach, and if the effect of de-

watering north of El Segundo Boulevard is ignored, the underflow into the Torrance-Inglewood subarea in the period 1933-41 can be estimated to be about 86 percent as great as in 1904 (product of differential head times cross-sectional area, for each segment).

5. In the same way, the underflow into the Torrance-Inglewood subarea as of 1945 can be estimated to be about the same as in 1904. If the dewatering along the crest north of El Segundo Boulevard is considered wholly effective in proportionately reducing the underflow to the west basin, then, the underflow as of 1945 would have been about 90 percent as great as in 1904, with respect to the Silverado zone and correlative deposits.

Of all water-bearing deposits of Pleistocene age along the reach from the Baldwin Hills to Los Cerritos—that is, the extensively dewatered upper Pleistocene deposits as well as the Silverado zone and correlative deposits of early Pleistocene age—it is estimated that the underflow as of 1945 was about 85 percent as great as in 1904.

#### METHODS OF ESTIMATING UNDERFLOW

The underflow to the Torrance-Inglewood subarea from the main coastal basin comprises two elements, (1) the underflow in the Gaspar water-bearing zone of Recent age, which passes into the west basin through the throat of Dominguez Gap, and (2) the underflow through all the aquifers of Pleistocene age, of which the Silverado water-bearing zone and correlative aquifers constitute the principal conduit.

The Gaspar water-bearing zone is not cut by the barrier features of the uplift—specifically, the Cherry-Hill fault (pl. 12)—and thus no differential in water level has been developed. Accordingly, the underflow to the west basin through this aquifer can be estimated as the product of the permeability, the cross-sectional area, and the hydraulic gradient. The permeability has been estimated to be about 3,000 gpd per square foot (p. 31), the cross-sectional area at the throat between Dominguez Hill and Los Cerritos is about 72 foot-miles (width 1.2 miles parallel to the ground-water contours, and thickness about 60 feet), and the hydraulic gradient through the throat has been about 12 feet to the mile in recent years (pl. 11). Thus, the current underflow to the west basin through the Gaspar water-bearing zone is estimated at about 4 cfs, or about 2,900 acre-feet per year.

The quantity of underflow to the Torrance-Inglewood subarea through the deposits of Pleistocene age also could be estimated directly if: (1) the permeability of the water-bearing deposits from place to place along the crest of the uplift had been determined by means of a sufficient number of pumping tests to afford reliable control; (2) the average hydraulic gradient across the crest were known for the particular instants or periods of appraisal; and (3) the amount of withdrawal between the crest of the uplift and the inland boundary of the west basin were known, so it could be subtracted from the underflow passing

the crest. Neither the permeability nor the crestal hydraulic gradient can be evaluated with reasonable accuracy at this time. In the 3-mile reach from the top of Dominguez Hill to the Los Angeles River not a single water well taps the Silverado water-bearing zone immediately inland from the barrier faults. It is here that the greatest differential in pressure level now exists across the barrier features of the uplift. During this investigation an attempt was made, with the cooperation of the Los Angeles County Flood Control District, to utilize certain oil-test holes for obtaining data on the permeability and piezometric level of the Silverado zone within this critical reach; however, the negotiations were unsuccessful.

The importance of obtaining accurate data on the hydraulic gradient can be illustrated by the following example. If the average permeability along the crestal reach is assumed for the moment to be 1,000 gpd per square foot, the quantity of water transmitted across the saturated crestal section of the Silverado zone and correlative deposits in 1945 would have been about 3,400 acre-feet per year for each foot per mile of hydraulic gradient.

The quantity of underflow passing into the Torrance-Inglewood subarea through the Silverado water-bearing zone and correlative deposits could be estimated by another method. The axis of the pressure trough, as shown on plates 9 to 12, marks the boundary between water moving inland and water moving coastward. That axis has migrated inland in recent years because the draft from the Torrance-Inglewood subarea has increased about 50 percent while the underflow has remained roughly constant. The quantity of water withdrawn between the barrier and the axis of the pressure trough—that is, within the area underlain by a coastward gradient—is a measure of the replenishment by underflow. It is impossible to estimate this draft accurately at present. For example, the axis of the pressure trough as of 1945 passed through the main well field of the Dominguez Water Corp. (pl. 12, plant 14b). The proportion of water contributed to this well field from the inland side (coastward hydraulic gradient) and from the coastward side (landward hydraulic gradient) cannot be determined without constructing additional observation wells to indicate the steepness of the coastward gradient as compared to the landward gradient.

However, as plates 9 and 11 suggest, the coastward hydraulic gradient on the inland side of the trough of pressure relief is somewhat steeper than the landward gradient on the oceanward side of the cone. If, for purposes of rough calculation, it is assumed that the coastward hydraulic gradient to such pumping plants along the axis of the pres-

sure trough was twice as great as the inland gradient in 1945, and presuming that the transmissibility of the deposits on the two sides is the same, then the contribution from the inland side would be two-thirds of the total to such well fields. On the basis of this assumption, the underflow from the main coastal basin to the Torrance-Inglewood subarea through the Silverado water-bearing zone as of 1945 is estimated roughly to have been about 12,000 to 16,000 acre-feet per year. If the estimated underflow through the upper Pleistocene deposits and through the Gaspur water-bearing zone is added to this, the total contribution to the Torrance-Inglewood subarea by underflow from the main coastal basin in 1945 is estimated to have been within the range of 15,000 to 20,000 acre-feet.

#### FACTORS AFFECTING CURRENT AND FUTURE REPLENISHMENT

The net replenishment to the Torrance-Inglewood subarea from 1933 to 1941 has been estimated at about 34,000 acre-feet per year (p. 148-155). Although the withdrawal as of 1945 had increased to some 78,000 acre-feet (table 8), or to about 160 percent of the average yearly draft of the thirties, the net replenishment in 1945 is believed not to have differed greatly from that of the thirties. Because the average differential in the water level across the barrier features is believed to have increased by a few feet from the thirties into 1945 (p. 158), the underflow to the Torrance-Inglewood subarea probably was slightly greater in 1945 than in the thirties. Therefore, because the sum of the other elements of net replenishment is considered to have been about equal in years of average rainfall, the net replenishment of the middle forties presumably has been at least equal to and probably slightly in excess of that of the thirties.

The increase in draft during the war years drew down the water levels substantially in the Torrance-Inglewood subarea and steepened the landward hydraulic gradient along the coastal reaches of the basin. The ocean-water or subsea contribution, which is estimated to have been about 12,000 acre-feet per year in the thirties, is believed to have more than doubled by the end of 1945. Additional drawdown of the water levels in the Torrance-Inglewood subarea would increase the rate of ocean-water contribution in direct proportion to the increase in landward hydraulic gradient along the coastal reach.

If a decrease in draft should occur and water levels in the Torrance-Inglewood subarea should remain about constant for the next few years, and if water levels in the main coastal basin should be drawn down appreciably below the levels of 1945, contributions by underflow from the main coastal basin, which are believed to constitute about

half the current net replenishment to the subarea, would be reduced roughly in proportion to the decrease in average differentials across the barrier. The reduction in underflow probably would be slightly greater than the decrease in differential head because of the effect of additional dewatering along the crest of the uplift. Thus, it is to the interest of water users in the west basin that water levels inland from the barrier be maintained as high as is feasible—in other words, replenishment to the Torrance-Inglewood subarea is affected beneficially by conservation of the water supply and increased replenishment to the groundwater reservoir throughout the coastal plain in Los Angeles County.

#### REPLENISHMENT TO THE CULVER CITY SUBAREA

Under initial conditions and to date, replenishment to the Culver City subarea has been supplied very largely by infiltration of runoff from the south flank of the Santa Monica Mountains west of the Inglewood fault and from rainwater penetration beneath the Santa Monica plain and within Ballona Gap. Initially, some replenishment doubtless passed coastward across the Inglewood fault from the main coastal basin. Since the middle twenties, however, little if any water has entered the Culver City subarea from the Pleistocene deposits to the east, because water levels in those deposits consistently have stood lower on the inland side of the Inglewood fault than on the coastal side. In the "50-foot gravel," however, a coastward gradient still prevails across the Inglewood fault and some water presumably passes into the Culver City subarea through this conduit.

In the crestal subbasin (between the Inglewood and Overland Avenue faults) withdrawal now is wholly from the San Pedro formation. The draft did not exceed a few hundred acre-feet per year until the middle thirties, when it increased to about 1,100 acre-feet per year (p. 108). Replenishment to the San Pedro formation is believed to be almost entirely from the north. As shown by the hydrographs for wells 2/14-7M1 and 18F1 (pl. 14), the water level declined at a gentle rate of about 0.6 foot per year in the early thirties, but it had declined at more than double that rate since 1936. The water-level trend in these observation wells must be interpreted with caution, because a general decline of water level in the subbasin would be expected to have occurred in response to drawdown of water levels to the south (escape area), east, and west, as well as to the increased withdrawal in the subbasin itself. Nevertheless, the evidence suggests that the replenishment under present conditions is somewhat less than the draft.

Replenishment to the Charnock subbasin as of 1904 was from: (1) the north by infiltration of rainfall and runoff on the Santa Monica

plain; (2) the east by movement of water from the crestal subbasin, probably largely through the "50-foot gravel," which is not cut by the Overland Avenue fault; and (3) by direct penetration of water from the land surface in the part of the subbasin within Ballona Gap. The concentrated withdrawal from the Charnock and Sepulveda well fields (p. 97 and pl. 12) has developed and maintained a central ground-water depression in which water levels have stood several tens of feet below sea level for the past two decades. Because of this great drawdown of water level, replenishment to the central part of the Charnock subbasin has been derived in part from the south since the late twenties. On the other hand, the general drawdown of water level within the Culver City subarea has largely dewatered the "50-foot gravel," and replenishment from the crestal subbasin to the east probably has about ceased, except for possible contributions across the Overland Avenue fault.

The draft from the Charnock subbasin is estimated to have ranged from 12,500 acre-feet in 1941 to 7,000 acre-feet in 1945. The hydrographs for wells 2/15-11E3 and 24C1 (pl. 14) suggest that in 1945 the replenishment was about equal to the estimated draft of 7,000 acre-feet. The water-level contours of plate 12 suggest that the hydraulic gradient from the north was then about  $2\frac{1}{2}$  times as steep as that from the south, and thus—assuming uniform permeability of the water-bearing material—that more than two-thirds of the replenishment was from the north. With respect to replenishment from the south, the water-level contours of plates 9-12 suggest that some of this replenishment moves northward from south of the Ballona escarpment, possibly in part from the crestal subbasin around the south end of the Overland Avenue fault.

The coastal area apparently receives almost all its replenishment from the Santa Monica upland to the north and by direct infiltration of rainwater in Ballona Gap. Through the thirties, when water levels stood below sea level, it also received substantial recharge from the ocean. For the past two decades no replenishment has moved westward across the Charnock fault. In fact, with the great differential in water levels that has existed across the Charnock fault since the late twenties, some water probably has moved inland across the fault.

The draft in the coastal area in the forties is estimated to have been between 2,000 and 3,000 acre-feet per year. The hydrographs for wells 2/15-16F1 and 22B4 (pl. 14) suggest that the replenishment from all sources has been at least equal to this draft in recent years.

**CHEMICAL CHARACTER OF NATIVE AND CONTAMINATED  
GROUND WATERS**

**GENERAL NATURE OF THE CHEMICAL PROBLEMS**

Locally, in the early twenties and more widely in the early thirties, certain wells near the coast from Ballona Gap to and beyond Redondo Beach began to yield saline water, leading ultimately to abandonment of some wells in which the salinity of the water became so great that it could no longer be used.

The districts in the Torrance-Santa Monica area in which the chloride content of some or all of the ground-water bodies exceeded 100 ppm in 1945-46 are shown on plate 16. These districts include several bodies containing water of native inferior quality—specifically, a part of the Wilmington district, a narrow zone extending along the north flank of the Palos Verdes Hills, the Gardena area, an area between Hawthorne and Inglewood, and a narrow strip along the west edge of the Baldwin Hills. They also include areas of inferior water in Dominguez Gap, along the coast from Redondo Beach to El Segundo, and in Ballona Gap, which have developed from progressive contamination during the past two decades; these are identified by diagonal ruling on plate 16.

The approximate extent of saline contamination in 1931-32 is also shown and represented by the boundaries of contaminated waters then containing more than about 100 ppm of chloride. Thus, the spread of contamination in the 14-year period is indicated by the relative position of the two boundaries.

In the Gardena area, the native waters of inferior quality occur within the shallow unconfined water body. In all the other districts underlain by water of more than 100 ppm of chloride, the inferior water is in the principal water body.

In Dominguez Gap, native waters of inferior quality occurring in the shallow unconfined body have become contaminated extensively during the past two decades. However, contamination has developed more widely in certain underlying water-bearing deposits in the principal water body—specifically in the Gaspur water-bearing zone and in the unnamed upper Pleistocene deposits to depths of 150 to 200 feet below land surface. In Dominguez Gap, the extent of contamination as shown on plate 16 relates to conditions in the principal water body and not to those in the shallow unconfined body.

Within the west basin and outside of the districts underlain by inferior waters as indicated on plate 16, a few wells tapping the principal water body yield water containing more than 100 ppm of chloride. Although these are not identified on plate 16, several of the wells are treated in the text beyond.

Because of the increased development of ground water in the west basin and the continuing decline in ground-water levels, local agencies that draw water from the basin or are concerned with the conservation of ground water have become increasingly alarmed by the spread of saline contamination.

Following sections of this report treat this problem of saline contamination by: (1) describing the chemical character and extent of waters of good quality and of inferior quality existing under native conditions; (2) describing the sources of saline contamination insofar as they can be identified; (3) determining the present extent of salt-water encroachment in the several water-bearing zones in the west basin; and (4) evaluating the possibilities for saline contamination to become more extensive in the future.

#### SCOPE AND SOURCES OF ANALYTICAL DATA

In connection with the canvass of water wells within the coastal plain by Mendenhall (1905a, 1905b) in 1903-4, the approximate dissolved-solids content of the water from about 2,500 wells in the Torrance-Santa Monica area was computed from their electrical conductances. Except for these determinations, only a few analyses are available for the period prior to 1929. The bulk of chemical analyses are for well waters sampled since that time—beginning chiefly in 1931-32, that is, sampling programs of the several active agencies began at about the time that local contamination problems became serious. At the present time, a large amount of analytical data has accumulated; this information includes both comprehensive analyses and those in which only one or two constituents, usually chloride or bicarbonate, have been determined. The scope of these data and the term of record by each contributing agency have been given in an earlier report (Sinnott and Garrett, 1946). In all, about 1,500 comprehensive analyses and about 12,000 field (partial) analyses have been made available for study. The Geological Survey has drawn freely upon this information in compiling the part of this interpretive report that deals with the chemistry of native and contaminated waters in the Torrance-Santa Monica area. From these data, representative analyses have been selected (table 30) to show the character of native waters and the progressive development of contamination in critical areas.

In addition to the large number of analyses, several interpretive reports relating to the problems of saline contamination have been made. Nearly all of these reports have been made by or for the Los Angeles County Flood Control District and chiefly discuss contamina-



tion in Ballona Gap. Most of these have been cited earlier in this report (p. 9).

Beginning late in 1943 as a part of the field canvass, the Geological Survey sampled 427 water wells in the Torrance-Santa Monica area, subsequently 73 of these were resampled. About 46 wells in critical areas were sampled periodically to determine if any change in salinity was occurring. In addition, a number of wells were sampled repeatedly while pumping. In all, the Geological Survey made 667 field analyses, comprising determinations of electrical conductivity, soap hardness, and chloride. These analyses are presented in table 29. Also, the Geological Survey has made 12 preliminary analyses in which electrical conductivity, soap hardness, calcium, bicarbonate, sulfate, chloride, borate, and iodide were determined; and 21 comprehensive analyses were made. These 33 analyses are included in table 30.

Plate 17 shows the location of wells for which chemical analyses are available from all sources, and indicates by symbol the type of analysis made. This plate also shows the water-quality data of Mendenhall by means of contours which indicate the approximate content of dissolved solids in parts per million. Necessarily, some generalization has been made; however, these contours suggest the approximate quality of the ground water under native conditions. During the survey by Mendenhall the approximate dissolved-solids content of the samples from about 7,500 wells—of which about 2,500 were within the Torrance-Santa Monica area—was computed from determinations of their electrical conductances, corrected to 60°F. The relationship between electrical conductivity and the approximate dissolved-solids content of natural waters within the coastal plain in Los Angeles and Orange Counties has been set forth in a recent report (Piper, Garrett, and others, 1953, p. 10, 11, and pl. 3). This relationship is a simple one and in many cases obviates the need for a gravimetric determination of dissolved solids.

#### **CHARACTER AND DISTRIBUTION OF NATIVE WATERS IN THE DEPOSITS COMMONLY PENETRATED BY WATER WELLS**

##### **RANGE IN CHEMICAL CHARACTER OF WATER FROM WELLS**

Native waters tapped by wells in the Torrance-Santa Monica area vary widely in quality from excellent to markedly inferior. For purposes of this report, water is considered inferior when its dissolved-solids content is more than about 600 ppm (Piper, Garrett, and others, 1953, p. 50). In general, all the confined waters in that part of the area inland from the Newport-Inglewood uplift are of good to excellent quality and are suitable for all domestic and irrigation purposes

and for industrial use with only moderate treatment. These are chiefly calcium-bicarbonate waters; their chloride content ranges from 20 to 30 ppm and their hardness from 150 to 225 ppm. In this report, terms describing the general chemical character of a water are used in particular senses, as in the following examples: (1) Calcium bicarbonate designates a water in which calcium amounts to 50 percent or more of the bases and bicarbonate to 50 percent or more of the acids, in chemical equivalents; (2) sodium calcium bicarbonate designates a water in which sodium and calcium are first and second, respectively, in order of abundance among the bases but neither amounts to 50 percent of all the bases; and (3) sodium sulfate bicarbonate designates a water in which sulfate and bicarbonate are first and second in order of abundance among the acids, as above.

Coastward from the Newport-Inglewood uplift within the west basin, native waters of good quality range in character from calcium to sodium bicarbonate. Except locally, the chloride in confined waters here ranges about from 30 to 200 ppm, but those containing more than about 100 ppm are considered inferior because their dissolved-solids content is usually in excess of 600 ppm. Locally, the chloride content of certain presumed native confined waters is as high as 400 ppm, although it is possible that some of these have been contaminated in recent years.

Unconfined waters on both sides of the Newport-Inglewood uplift are generally inferior but are poorest in quality on the coastal side. The chloride in these waters is as great as 2,200 ppm and dissolved solids as much as 4,000 ppm.

To show the overall range in chemical character of waters in the Torrance-Santa Monica area, chemical analyses of 375 samples from 338 wells have been plotted on figure 9. This method of plotting well waters has been used earlier to show the chemical character of water from wells in the Long Beach-Santa Ana area. The plotted positions of the analyses on the graph are dependent upon the predominating chemical constituents in the water. Hence, water types can be recognized at once by inspection of the graph. Additional explanation is given on figure 9. This plate presents almost all of the analytical data available to the Geological Survey in graphic form. Included on the graph are analyses of (1) native waters of good quality, (2) native waters of poor quality, (3) native blended waters, and (4) contaminated waters—those native waters that have been modified by the addition of inferior waters from sources exterior to the initial native water body.

The native waters of diverse character can be divided in a general way into several types; each type is more or less characteristic of a

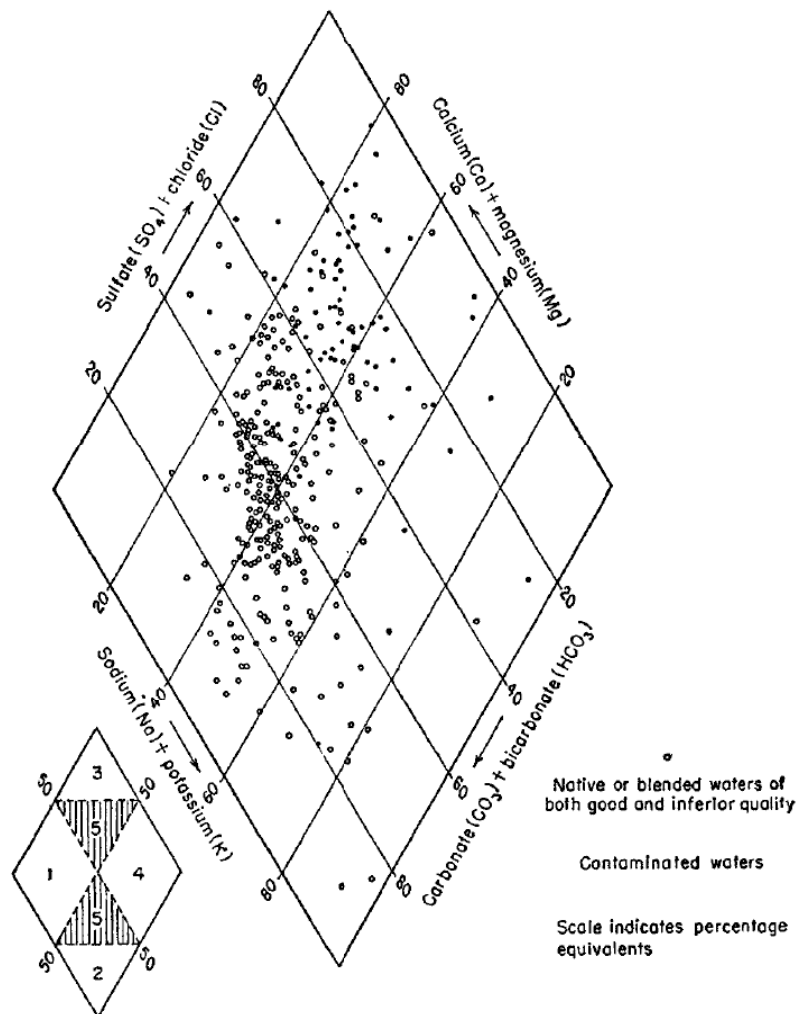

KEY DIAGRAM

- Area 1 Carbonate hardness exceeds 50 percent
- 2 Carbonate alkali exceeds 50 percent
- 3 Noncarbonate hardness exceeds 50 percent
- 4 Noncarbonate alkali exceeds 50 percent
- 5 None of the preceding characteristics exceeds 50 percent

FIGURE 9.—Chemical character of 375 water samples from 338 wells in the Torrance-Santa Monica area, 1929-46.

stratigraphic range. The zones of water quality associated with certain stratigraphic ranges are discussed later in this section.

#### ZONES OF WATER QUALITY

In the Long Beach-Santa Ana area, eight distinct vertical ranges of water quality have been discriminated within the deposits tapped by water wells (Piper, Garrett, and others, 1953, p. 17-18). Each of these except the uppermost—that occupied by the body of unconfined water—coincides roughly with a particular stratigraphic zone. In general, the waters of the several ranges as delineated differ from each other in chemical character. The difference in character is striking between certain ranges and between others it is minor. Similarly, in the Torrance-Santa Monica area each zone of water quality coincides in a general way with a particular stratigraphic range. As in the Long Beach-Santa Ana area, differences in character between adjacent ranges may be small, and water of uniform character does not necessarily exist throughout the lateral extent of any one range. However, although the full stratigraphic sequence of the Long Beach-Santa Ana area prevails in the Torrance-Santa Monica area, only six ranges of water quality have been discriminated. Certain of these ranges span stratigraphic intervals identical with those of their counterparts in the Long Beach-Santa Ana area to the east; others span a more inclusive stratigraphic interval.

In both the Long Beach-Santa Ana and the Torrance-Santa Monica areas the uppermost range is that occupied by the semiperched and essentially unconfined water body in the upper part of the alluvial deposits of Recent age in Dominguez and Ballona Gaps and in the topmost part of the upper Pleistocene deposits beneath the Torrance plain. Commonly, the semiperched water body in both the Recent and Pleistocene deposits is separated from the underlying principal water body by a few tens of feet of relatively impermeable layers of silt and clay.

The five ranges in the principal confined ground-water body in the Torrance-Santa Monica area have been assigned numbers identical to those used for comparable ranges in the Long Beach-Santa Ana area. In downward succession, these five ranges are as follows:

*Range 1.*—The lower division of the Recent deposits, which includes the Gaspur water-bearing zone of Dominguez Gap and the “50-foot gravel” of Ballona Gap. In Dominguez Gap the Gaspur water-bearing zone is 40 to 60 feet thick and its base is about 120 feet below land surface. In Ballona Gap, the base of the “50-foot gravel” is about 50 feet below land surface, and its thickness ranges from 10 to 40 feet. Locally the “50-foot gravel” is in hydraulic continuity with underlying permeable Pleistocene deposits. The extent of the

Gaspar water-bearing zone and the "50-foot gravel" is shown on plate 18.

*Range 2.*—The Long Beach-Santa Ana area, the uppermost Pleistocene deposits beneath the Downey plain, is not differentiated from range 3 in the Torrance-Santa Monica area.

*Range 3.*—The unnamed upper Pleistocene deposits, including the "200-foot sand" and strata correlative with or in hydraulic continuity with those deposits, ranges in thickness from a feather edge at the Baldwin and Palos Verdes Hills to as much as 300 feet along the synclinal trough within the west basin. The base of this range commonly is from 200 to 300 feet below land surface in the west basin.

*Range 4.*—In the Long Beach-Santa Ana area—the uppermost part of the San Pedro formation beneath the Downey plain—is not differentiated in the Torrance-Santa Monica area.

*Range 5.*—The upper part of the San Pedro formation, including the "400-foot gravel" of the area between Gardena and Inglewood, but excluding the Silverado water-bearing zone. In general, this is the stratigraphic equivalent of range 5 of the Long Beach-Santa Ana area. In the west basin, this range is thickest in the synclinal trough (as much as 200 feet); along the crest of the Newport-Inglewood uplift, although this range is present, it is substantially thinner. Along much of the coast from Redondo Beach to Santa Monica the range decreases in thickness to a feather edge or is entirely absent. Along the synclinal trough the base of this range is about 300 feet below land surface in Inglewood, about 400 feet below at Gardena, and as much as 700 feet below in Dominguez Gap, near the intersection of Alameda Boulevard and Carson Street. In Ballona Gap, just inland from the Newport-Inglewood uplift—specifically, in 1/14-32M and 2/14-5D—the San Pedro formation has been divided tentatively into an upper, a middle, and a lower part (fig. 14). However, the separation is intended primarily for local subdivision of the formation on the basis of water-bearing zones and is derived chiefly from examination of logs of wells at the Sentney plant of the Southern California Water Co. Although the upper part of the San Pedro formation here may not be correlative with any part of range 5, as here defined, it has been found most feasible to include the waters yielded from this upper part of the San Pedro formation in that range.

*Range 6.*—The middle and lower parts of the San Pedro formation, including the Silverado water-bearing zone of the Torrance-Inglewood subarea and the main water-bearing zone in Ballona Gap coastward from the Newport-Inglewood uplift—the essential correlative of the

Silverado zone. Within the west basin the thickness of this range is as much as 600 feet between Wilmington and Redondo Beach, but northward from Gardena the thickness commonly does not exceed 200 feet and in Inglewood it is as little as 50 feet. The depth of its base is shown by the contours of plate 2. In Ballona Gap, just inland from the Newport-Inglewood uplift, the aggregate thickness of the middle and lower parts is probably about 230 feet, and the top of the middle part is about 290 feet below land surface. In the Long Beach-Santa Ana area, range 6 included the lower part of the Silverado water-bearing zone; there the upper part was included in range 5. However, range 6 includes the full vertical extent of the Silverado zone. In other respects, range 6 of the two areas is essentially common.

*Range 7.*—The upper division of the Pico formation underlies nearly all the west basin. This range contains the deepest fresh waters known to occur in the area, although its waters are brackish locally north of Ballona Gap. Its vertical range has been described on pages 57–59. The depth of its base, where known, is shown on plate 8.

On following pages the waters contained in the six ranges of the Torrance-Santa Monica area are described in detail; on plates 18 and 19 are plotted the wells from which native waters have been selected that are considered representative of the respective ranges tapped. For each of the waters so selected, the dissolved solids content and a “binomial symbol” are shown on the plates 18 and 19. The binomial symbol is written in the form of a decimal fraction. The first term denotes the percentage of hardness-causing constituents among the bases—that is, of calcium and magnesium; the second term denotes the percentage of bicarbonate—and carbonate calculated to bicarbonate—among the acids. For example, the symbol 60.75 would indicate a water in which the calcium and magnesium amount to 60 percent of all the bases, in terms of chemical equivalents, and in which bicarbonate (including carbonate, if present) amounts to 75 percent of all the acids.

The complement of this binomial symbol indicates the percentage amounts of non-hardness-causing constituents or “alkalis” among the bases, and of noncarbonate acids. In the example here given, the complement is 40.25, which indicates 40 percent sodium and potassium [the “percent sodium” of Scofield (1933, p. 22–23)] and 25 percent sulfate and chloride, in chemical equivalents.

The analyses selected as representative for native waters are listed on table 16 and are grouped according to their respective ranges.

172 GEOLOGY, HYDROLOGY, TORRANCE-SANTA MONICA AREA

TABLE 16.—Analyses of representative native ground waters  
 [See table 30 for description of sources and for analytical data in parts per million]

| Well                                                                                                                                               | Dissolved solids (parts per million) | Constituents (percentage equivalents) |                |                             |                                              |                            |                            |
|----------------------------------------------------------------------------------------------------------------------------------------------------|--------------------------------------|---------------------------------------|----------------|-----------------------------|----------------------------------------------|----------------------------|----------------------------|
|                                                                                                                                                    |                                      | Calcium (Ca)                          | Magnesium (Mg) | Sodium and potassium (Na+K) | Bicarbonate (HCO <sub>3</sub> ) <sup>1</sup> | Sulfate (SO <sub>4</sub> ) | Chloride (Cl) <sup>2</sup> |
| <b>Waters from the unconfined shallow body</b><br>[Location of sources shown on plate 18]                                                          |                                      |                                       |                |                             |                                              |                            |                            |
| 3/13-27B1.....                                                                                                                                     | * 954                                | 34.0                                  | 24.4           | 41.6                        | 46.4                                         | 22.8                       | 30.8                       |
| 30P1.....                                                                                                                                          | * 1,125                              | 39.4                                  | 26.2           | 34.4                        | 31.8                                         | 16.6                       | 51.6                       |
| 31H4.....                                                                                                                                          | * 924                                | 48.4                                  | 20.8           | 30.8                        | 27.0                                         | 22.6                       | 50.4                       |
| 3/14-26G2.....                                                                                                                                     | * 3,907                              | 37.2                                  | 21.0           | 41.8                        | 5.4                                          | 6.4                        | 88.2                       |
| 4/13-8LI.....                                                                                                                                      | * 3,609                              | 25.0                                  | 28.0           | 47.0                        | 7.2                                          | 46.2                       | 46.6                       |
| Minimum.....                                                                                                                                       | 924                                  | 25.0                                  | 20.8           | 30.8                        | 5.4                                          | 6.4                        | 30.8                       |
| Maximum.....                                                                                                                                       | 3,907                                | 48.4                                  | 28.0           | 47.0                        | 46.4                                         | 46.2                       | 88.2                       |
| <b>Waters from the Gaspar water-bearing zone or "50-foot gravel" in alluvial deposits of Recent age</b><br>[Location of sources shown on plate 18] |                                      |                                       |                |                             |                                              |                            |                            |
| 2/14-5D9.....                                                                                                                                      | * 747                                | 43.6                                  | 29.2           | * 27.2                      | 48.0                                         | 28.4                       | 23.6                       |
| 3/13-36D1.....                                                                                                                                     | 404                                  | 52.6                                  | 13.6           | * 33.8                      | 68.6                                         | 19.6                       | 11.8                       |
| 4/13-2P4.....                                                                                                                                      | * 338                                | 52.4                                  | 11.4           | 36.2                        | 62.0                                         | 25.6                       | 12.4                       |
| 15A3.....                                                                                                                                          | * 449                                | 50.2                                  | 17.0           | 32.8                        | 52.8                                         | 28.6                       | 18.6                       |
| 35M3.....                                                                                                                                          | * 318                                | 23.2                                  | 15.6           | * 61.2                      | 66.2                                         | 14.4                       | 19.4                       |
| Minimum.....                                                                                                                                       | 318                                  | 23.2                                  | 11.4           | 27.2                        | 48.0                                         | 14.4                       | 11.8                       |
| Maximum.....                                                                                                                                       | 747                                  | 52.6                                  | 29.2           | 61.2                        | 68.6                                         | 28.6                       | 23.6                       |
| <b>Waters from unnamed upper Pleistocene deposits including the "200-foot sand"</b><br>[Location of sources shown on plate 18]                     |                                      |                                       |                |                             |                                              |                            |                            |
| 2/14-29K1.....                                                                                                                                     | 442                                  | 46.0                                  | 20.8           | * 33.2                      | 57.0                                         | 11.6                       | 31.4                       |
| 32E1.....                                                                                                                                          | * 496                                | 37.6                                  | 24.0           | * 38.4                      | 59.8                                         | 13.8                       | 26.4                       |
| 3/13-20H1.....                                                                                                                                     | 362                                  | 51.4                                  | 19.0           | 29.6                        | 60.0                                         | 28.0                       | 12.0                       |
| 3/14-26J1.....                                                                                                                                     | * 377                                | 44.2                                  | 20.4           | 35.4                        | 54.2                                         | 8.6                        | 37.2                       |
| 4/13-6J1.....                                                                                                                                      | * 308                                | 51.4                                  | 14.8           | 33.8                        | 63.4                                         | 24.8                       | 11.8                       |
| 4/13-19H1.....                                                                                                                                     | 518                                  | 46.0                                  | 17.0           | 37.0                        | 39.2                                         | 14.8                       | 46.0                       |
| 19J4.....                                                                                                                                          | * 787                                | 34.2                                  | 19.2           | 46.6                        | 30.4                                         | 5.4                        | 64.2                       |
| Minimum.....                                                                                                                                       | 308                                  | 34.2                                  | 14.8           | 29.6                        | 30.4                                         | 5.4                        | 11.8                       |
| Maximum.....                                                                                                                                       | 787                                  | 51.4                                  | 24.0           | 46.6                        | 63.4                                         | 28.0                       | 64.2                       |
| <b>Waters from the "400-foot gravel" in upper part of San Pedro formation</b><br>[Location of sources shown on plate 18]                           |                                      |                                       |                |                             |                                              |                            |                            |
| 3/14-10C1.....                                                                                                                                     | * 347                                | 34.2                                  | 17.8           | * 43.0                      | 69.8                                         | 13.6                       | 16.6                       |
| 15G1.....                                                                                                                                          | * 359                                | 42.0                                  | 21.2           | * 36.8                      | 65.0                                         | 19.6                       | 15.4                       |
| 23L1.....                                                                                                                                          | * 323                                | 46.2                                  | 21.0           | * 32.8                      | 62.0                                         | 24.6                       | 13.4                       |
| Minimum.....                                                                                                                                       | 323                                  | 34.2                                  | 17.8           | 32.8                        | 62.0                                         | 13.6                       | 13.4                       |
| Maximum.....                                                                                                                                       | 359                                  | 46.2                                  | 21.2           | 43.0                        | 69.8                                         | 24.6                       | 16.6                       |

<sup>1</sup> Includes carbonate (CO<sub>3</sub>) and borate (BO<sub>3</sub>), if determined.  
<sup>2</sup> Includes fluoride (F) and nitrate (NO<sub>3</sub>), if determined.  
<sup>3</sup> Calculated.

TABLE 16.—Analyses of representative native ground waters—Continued

[See table 30 for description of sources and for analytical data in parts per million]

| Well                                                                                                                                  | Dissolved solids (parts per million) | Constituents (percentage equivalents) |                |                             |                                              |                            |                            |
|---------------------------------------------------------------------------------------------------------------------------------------|--------------------------------------|---------------------------------------|----------------|-----------------------------|----------------------------------------------|----------------------------|----------------------------|
|                                                                                                                                       |                                      | Calcium (Ca)                          | Magnesium (Mg) | Sodium and potassium (Na+K) | Bicarbonate (HCO <sub>3</sub> ) <sup>1</sup> | Sulfate (SO <sub>4</sub> ) | Chloride (Cl) <sup>2</sup> |
| <b>Waters from the Silverado water-bearing zone, or, beyond that zone, from the middle and lower parts of the San Pedro formation</b> |                                      |                                       |                |                             |                                              |                            |                            |
| [Location of sources shown on plate 19]                                                                                               |                                      |                                       |                |                             |                                              |                            |                            |
| 2/14-4N1.....                                                                                                                         | 350                                  | 47.2                                  | 20.8           | 32.0                        | 61.6                                         | 27.4                       | 11.0                       |
| 5C1.....                                                                                                                              | 313                                  | 34.8                                  | 33.6           | 31.6                        | 59.4                                         | 17.6                       | 23.0                       |
| 5D6.....                                                                                                                              | 478                                  | 36.6                                  | 19.2           | 44.2                        | 63.6                                         | 20.8                       | 15.6                       |
| 14C2.....                                                                                                                             | 360                                  | 49.4                                  | 20.6           | 30.0                        | 61.0                                         | 26.8                       | 12.2                       |
| 19C1.....                                                                                                                             | 535                                  | 40.8                                  | 15.0           | 44.2                        | 65.2                                         | 12.0                       | 22.8                       |
| 2/14-22P1.....                                                                                                                        | 355                                  | 53.8                                  | 17.8           | 28.4                        | 61.6                                         | 26.6                       | 11.8                       |
| 23E2.....                                                                                                                             | 371                                  | 49.4                                  | 25.6           | 25.0                        | 59.4                                         | 27.2                       | 13.4                       |
| 2/15-1C2.....                                                                                                                         | 553                                  | 47.0                                  | 26.8           | 26.2                        | 52.0                                         | 30.8                       | 17.2                       |
| 11C6.....                                                                                                                             | 453                                  | 44.8                                  | 31.8           | 23.4                        | 51.0                                         | 31.7                       | 17.3                       |
| 11D2.....                                                                                                                             | 557                                  | 49.2                                  | 35.2           | 15.6                        | 50.6                                         | 37.8                       | 11.6                       |
| 2/15-11E1.....                                                                                                                        | 546                                  | 45.8                                  | 29.6           | 24.6                        | 48.0                                         | 37.0                       | 15.0                       |
| 11J1.....                                                                                                                             | 476                                  | 35.0                                  | 19.0           | 46.0                        | 60.0                                         | 19.8                       | 20.2                       |
| 14A1.....                                                                                                                             | 558                                  | 44.0                                  | 30.6           | 25.4                        | 52.0                                         | 26.8                       | 21.2                       |
| 15A4.....                                                                                                                             | 631                                  | 44.0                                  | 21.6           | 34.4                        | 44.6                                         | 37.2                       | 18.2                       |
| 15F2.....                                                                                                                             | 620                                  | 57.8                                  | 18.4           | 23.8                        | 43.6                                         | 39.4                       | 17.0                       |
| 2/15-15H1.....                                                                                                                        | 567                                  | 42.8                                  | 30.4           | 26.8                        | 48.0                                         | 32.4                       | 19.6                       |
| 24C1.....                                                                                                                             | 567                                  | 42.8                                  | 32.2           | 25.0                        | 51.2                                         | 38.2                       | 10.6                       |
| 28B1.....                                                                                                                             | 492                                  | 26.4                                  | 28.2           | 45.4                        | 65.0                                         | 8.6                        | 26.4                       |
| 34A1.....                                                                                                                             | 474                                  | 37.8                                  | 15.8           | 46.4                        | 61.0                                         | 7.8                        | 31.2                       |
| 34E1.....                                                                                                                             | 445                                  | 33.6                                  | 21.8           | 44.6                        | 59.4                                         | 11.4                       | 29.2                       |
| 3/13-6G1.....                                                                                                                         | 363                                  | 46.6                                  | 8.2            | 50.2                        | 64.0                                         | 24.6                       | 11.4                       |
| 3/14-1G1.....                                                                                                                         | 349                                  | 51.0                                  | 15.6           | 33.4                        | 63.4                                         | 24.0                       | 12.6                       |
| 8K2.....                                                                                                                              | 335                                  | 39.4                                  | 20.8           | 39.8                        | 72.8                                         | 11.2                       | 16.0                       |
| 4N1.....                                                                                                                              | 305                                  | 35.6                                  | 22.2           | 42.2                        | 80.4                                         | 3.4                        | 16.2                       |
| 9N3.....                                                                                                                              | 327                                  | 33.0                                  | 19.4           | 47.6                        | 83.0                                         | .2                         | 16.8                       |
| 3/14-10G1.....                                                                                                                        | 425                                  | 25.6                                  | 15.0           | 59.4                        | 86.8                                         | .8                         | 12.4                       |
| 13J3.....                                                                                                                             | 319                                  | 49.2                                  | 18.4           | 32.4                        | 62.4                                         | 23.6                       | 14.0                       |
| 21B2.....                                                                                                                             | 319                                  | 32.0                                  | 14.6           | 53.4                        | 84.2                                         | 1.2                        | 14.6                       |
| 30A2.....                                                                                                                             | 343                                  | 33.8                                  | 17.2           | 49.0                        | 85.0                                         |                            | 17.0                       |
| 35E1.....                                                                                                                             | 251                                  | 35.0                                  | 19.8           | 45.2                        | 82.8                                         | 1.2                        | 16.0                       |
| 3/15-1H1.....                                                                                                                         | 583                                  | 29.2                                  | 23.4           | 47.4                        | 71.2                                         | 5.6                        | 23.2                       |
| 12B1.....                                                                                                                             | 484                                  | 33.6                                  | 18.6           | 47.8                        | 75.0                                         | .2                         | 24.8                       |
| 13R1.....                                                                                                                             | 367                                  | 36.4                                  | 19.6           | 44.0                        | 77.4                                         | .0                         | 22.6                       |
| 24D1.....                                                                                                                             | 433                                  | 42.2                                  | 20.6           | 37.2                        | 67.0                                         | 2.6                        | 30.4                       |
| 25A4.....                                                                                                                             | 365                                  | 39.6                                  | 19.0           | 41.4                        | 57.2                                         | 7.0                        | 35.8                       |
| 4/13-14Q4.....                                                                                                                        | 236                                  | 27.2                                  | 11.4           | 61.4                        | 66.2                                         | 18.2                       | 15.6                       |
| 15A2.....                                                                                                                             | 208                                  | 23.8                                  | 13.8           | 62.4                        | 76.6                                         | 5.2                        | 18.2                       |
| 21Q1.....                                                                                                                             | 218                                  | 16.0                                  | 5.0            | 79.0                        | 82.0                                         |                            | 18.0                       |
| 22E1.....                                                                                                                             | 221                                  | 26.4                                  | 11.2           | 62.4                        | 81.2                                         | 1.6                        | 17.2                       |
| 30K1.....                                                                                                                             | 239                                  | 17.8                                  | 19.4           | 62.8                        | 85.8                                         | .4                         | 18.8                       |
| 4/13-31E3.....                                                                                                                        | 377                                  | 13.0                                  | 11.0           | 76.0                        | 72.4                                         | .0                         | 27.6                       |
| 31E4.....                                                                                                                             | 388                                  | 11.2                                  | 8.0            | 80.8                        | 61.0                                         | 10.8                       | 28.2                       |
| 4/14-1H.....                                                                                                                          | 252                                  | 43.4                                  | 14.2           | 42.4                        | 68.6                                         | 11.0                       | 20.4                       |
| 5N2.....                                                                                                                              | 308                                  | 35.6                                  | 24.6           | 39.8                        | 67.6                                         | 4.2                        | 28.2                       |
| 7J3.....                                                                                                                              | 320                                  | 35.2                                  | 17.6           | 47.2                        | 67.6                                         | 1.0                        | 31.4                       |
| 4/14-8C1.....                                                                                                                         | 344                                  | 33.0                                  | 18.8           | 48.2                        | 62.6                                         | .8                         | 36.6                       |
| 8E1.....                                                                                                                              | 327                                  | 31.6                                  | 22.0           | 46.4                        | 65.8                                         | 1.2                        | 33.0                       |
| 11G2.....                                                                                                                             | 267                                  | 27.8                                  | 20.4           | 51.8                        | 87.6                                         | .0                         | 12.4                       |
| 16L3.....                                                                                                                             | 291                                  | 18.8                                  | 7.4            | 73.8                        | 87.4                                         |                            | 12.6                       |
| 17G1.....                                                                                                                             | 325                                  | 27.2                                  | 16.8           | 56.0                        | 76.4                                         | .0                         | 23.6                       |
| 4/14-17N1.....                                                                                                                        | 427                                  | 28.2                                  | 20.0           | 51.8                        | 68.4                                         | 1.8                        | 29.8                       |
| 23N2.....                                                                                                                             | 332                                  | 15.2                                  | 8.0            | 76.8                        | 78.8                                         | .4                         | 20.8                       |
| 35E2.....                                                                                                                             | 547                                  | 29.6                                  | 6.6            | 63.8                        | 63.0                                         | 1.0                        | 36.0                       |
| 36E1.....                                                                                                                             | 334                                  | 22.0                                  | 19.2           | 68.8                        | 72.0                                         | .0                         | 23.0                       |
| Minimum.....                                                                                                                          | 206                                  | 11.2                                  | 3.2            | 15.6                        | 43.6                                         | .0                         | 10.6                       |
| Maximum.....                                                                                                                          | 631                                  | 57.8                                  | 35.2           | 80.8                        | 87.6                                         | 39.4                       | 36.6                       |

<sup>1</sup> Includes carbonate (CO<sub>3</sub>) and borate (BO<sub>3</sub>), if determined.  
<sup>2</sup> Includes fluoride (F) and nitrate (NO<sub>3</sub>), if determined.  
<sup>3</sup> Calculated.



## 174 GEOLOGY, HYDROLOGY, TORRANCE-SANTA MONICA AREA

TABLE 16.—Analyses of representative native ground waters—Continued

[See table 30 for description of sources and for analytical data in parts per million]

| Well                                                                          | Dissolved solids (parts per million) | Constituents (percentage equivalents) |                |                             |                                              |                            |                            |
|-------------------------------------------------------------------------------|--------------------------------------|---------------------------------------|----------------|-----------------------------|----------------------------------------------|----------------------------|----------------------------|
|                                                                               |                                      | Calcium (Ca)                          | Magnesium (Mg) | Sodium and potassium (Na+K) | Bicarbonate (HCO <sub>3</sub> ) <sup>1</sup> | Sulfate (SO <sub>4</sub> ) | Chloride (Cl) <sup>2</sup> |
| <b>Waters from undifferentiated Pleistocene deposits north of Ballona Gap</b> |                                      |                                       |                |                             |                                              |                            |                            |
| [Location of sources shown on plate 19]                                       |                                      |                                       |                |                             |                                              |                            |                            |
| 1/14-19R1.....                                                                | <sup>3</sup> 719                     | 49.8                                  | 34.6           | <sup>3</sup> 15.6           | 56.0                                         | 21.2                       | 22.8                       |
| 20M1.....                                                                     | <sup>3</sup> 683                     | 20.0                                  | 19.0           | <sup>3</sup> 61.0           | 67.0                                         | 4.2                        | 28.8                       |
| 1/15-28B2.....                                                                | <sup>3</sup> 569                     | 49.2                                  | 31.6           | 19.2                        | 53.2                                         | 26.4                       | 20.4                       |
| 32A1.....                                                                     | <sup>3</sup> 577                     | 42.0                                  | 36.6           | 21.4                        | 42.2                                         | 44.0                       | 13.8                       |
| Minimum.....                                                                  | 569                                  | 20.0                                  | 19.0           | 15.6                        | 42.2                                         | 4.2                        | 13.8                       |
| Maximum.....                                                                  | 719                                  | 49.8                                  | 36.6           | 61.0                        | 67.0                                         | 44.0                       | 28.8                       |
| <b>Waters from upper division of Pico formation</b>                           |                                      |                                       |                |                             |                                              |                            |                            |
| [Location of sources shown on plate 19]                                       |                                      |                                       |                |                             |                                              |                            |                            |
| 1/15-25C1.....                                                                | <sup>3</sup> 2,670                   | 40.2                                  | 30.2           | 29.6                        | 13.4                                         | 7.4                        | 79.2                       |
| 2/14-27J1.....                                                                | <sup>3</sup> 1,225                   | 4.2                                   | 3.0            | 92.8                        | 90.2                                         | 1.6                        | 8.2                        |
| 2/15-1C5.....                                                                 | <sup>3</sup> 1,698                   | 4.0                                   | 6.2            | <sup>3</sup> 89.8           | 38.2                                         | -----                      | 61.8                       |
| 3/14-17J1.....                                                                | <sup>3</sup> 481                     | 19.4                                  | 14.6           | <sup>3</sup> 66.0           | 77.6                                         | 6.2                        | 16.2                       |
| 4/18-12A2.....                                                                | <sup>3</sup> 452                     | 5.2                                   | 2.0            | <sup>3</sup> 92.8           | 79.2                                         | 1.6                        | 19.2                       |
| 5/13-3H.....                                                                  | <sup>3</sup> 750                     | 7.6                                   | 3.4            | <sup>3</sup> 89.0           | 68.0                                         | .8                         | 31.2                       |
| Minimum.....                                                                  | 452                                  | 4.0                                   | 2.0            | 29.6                        | 13.4                                         | .0                         | 8.2                        |
| Maximum.....                                                                  | 2,670                                | 40.2                                  | 30.2           | 92.8                        | 90.2                                         | 7.4                        | 79.2                       |

<sup>1</sup> Includes carbonate (CO<sub>3</sub>) and borate (BO<sub>3</sub>), if determined.<sup>2</sup> Includes fluoride (F) and nitrate (NO<sub>3</sub>), if determined.<sup>3</sup> Calculated.

## CHEMICAL CHARACTER OF THE WATERS

## UNCONFINED WATERS

In general, the native unconfined waters in the Torrance-Santa Monica area are of poor quality. Only locally are they used for domestic or irrigation purposes. Commonly, the high salinity of the water and the low permeability of the shallow deposits discourage extensive development.

The unconfined waters in Dominguez Gap generally range from 175 to 2,200 ppm in chloride content and from 1,000 to 12,900 ppm in dissolved solids; they are chiefly sodium sulfate to sodium sulfate, chloride waters. Typically, the bicarbonate content is high, ranging from 250 to 1,100 ppm. It is likely that these unconfined waters have been concentrated by evaporation and, locally, by addition of saline waters at land surface, and thus they do not represent native waters. Therefore, no conclusion can be set forth here in regard to the chemical character of these waters under purely native conditions. Probably, however, their chloride content was usually more than 100 ppm.

Near Gardena, about in secs. 24 to 27, T. 3 S., R. 14 W., and in secs. 29 and 30, T. 3 S., R. 13 W. (pl. 16), many domestic wells tapped the unconfined water body in 1903, as shown by the well canvass of that time. As of 1946, the body is tapped by about 100 active wells. The salinity of these unconfined waters is low enough at least locally, to be used for domestic purposes and for irrigation. Their chloride content ranges from 50 to 2,200 ppm but commonly it is from 300 to 500 ppm. An analysis of water from well 3/14-26G2 (table 30) indicates a sodium, calcium chloride water. No other complete analyses of the unconfined water in this area have been made, so far as known, but it is inferred that the proportion of sulfate and bicarbonate in these waters is somewhat lower than in Ballona Gap. On the basis of determinations of electrical conductivity, the dissolved solids are estimated to range from 1,000 to 4,000 ppm.

In Ballona Gap, as of 1903, many domestic and stock wells 10 to 30 feet deep tapped the shallow water body. At that time the dissolved solids in these unconfined waters ranged from 750 to more than 2,000 ppm, but chiefly were about 1,000 ppm; all estimates were based on determinations of electrical conductivity. Locally, however, the dissolved solids of these waters ranged from 1,500 to 2,300 ppm. Presumably, the water quality as determined in 1903 was essentially native. Because of the gradual drawdown of the water levels in Ballona Gap during the twenties and early thirties, many of these shallow wells went dry. Others were abandoned as a result of deterioration in the quality of the water. By the middle thirties none of these early shallow wells were in use. About all that is known concerning the quality of the unconfined water body in recent years has been obtained from 19 shallow wells bored by the Los Angeles County Flood Control District since 1936; almost all these wells were located in the reach between Lincoln and Centinela Boulevards. That agency has made complete analyses of water from two of these wells and partial analyses from five others. The two complete analyses (2/15-23Q1 and 23Q2, table 30) indicate that locally in sec. 23 the shallow unconfined waters are sodium sulfate to sodium, calcium sulfate waters. The partial analyses, which span a more extensive reach, show a chloride content ranging from 170 to 300 ppm. On the other hand, samples taken in 1943-45 from well 2/15-23M2, adjacent to the Ballona Creek channel and 13 feet deep, ranged in chloride content from 2,600 to 11,580 ppm. The channel here is within the reach of tidal water; doubtlessly, this accounts for the very high salinity of water from that well.

The chemical data for the unconfined water in Ballona Gap are so incomplete that its regional chemical character is not known, either under native conditions or in recent years. The complete analyses

from wells 2/15-23Q1 and Q2 (table 30) are probably not of native waters but instead, they concern waters concentrated by evaporation, by the possible addition of saline waters at land surface, or by infiltration of ocean water. However, from knowledge of the native quality of the unconfined body in other areas, it is reasonable to expect that even under native conditions the sulfate content was somewhat high.

Inland from the Newport-Inglewood zone, but proximate to it, little is known in regard to the character of the shallow waters because of the dearth of chemical analyses. One well, 3/13-27B1, in 1932 yielded a sodium, calcium bicarbonate, chloride water. The chloride and dissolved-solids contents of this water were 181 and 954 ppm, respectively. The well is 8 feet deep and taps Recent deposits. The chemical character of the unconfined waters beneath the Downey plain has been discussed in an earlier report (Piper, Garrett, and others, 1953, p. 21, 26, 51).

#### CONFINED WATERS

##### WATERS IN RANGE I (GASPUR WATER-BEARING ZONE AND "50-FOOT GRAVEL")

The Gaspur water-bearing zone extends from the coast through Dominguez Gap and inland to Whittier Narrows. Only the coastal 8-mile segment is within the Torrance-Santa Monica area, however (pl. 18). Inland from the Newport-Inglewood uplift the native waters of the Gaspur zone contain about 250 to 350 ppm of dissolved solids and about 175 to 225 ppm of hardness. All are calcium bicarbonate waters. Across the Newport-Inglewood belt and within the west basin, the native waters gain in dissolved solids about 25 to 40 percent, so that concentrations are as much as 450 ppm, largely owing to an increase in sulfate, chloride, sodium, and calcium. This increase may be due to contributions of water from the westerly "arm" of the Gaspur zone. However, at the present time much of the Gaspur zone throughout its extent in the west basin is either incipiently or definitely contaminated either from local sources or from the ocean to the extent that the native character of the water is completely obscured (pl. 16).

The "50-foot gravel" in Ballona Gap contained water ranging from 650 to 750 ppm of dissolved solids in 1903-4; this estimate is based upon determinations of electrical conductance. Locally, however, the dissolved-solids content was at least 850 ppm. Fragmentary data available suggest that ocean-water intrusion had not then occurred. In general, the water in the "50-foot gravel" initially was of substantially better quality than the unconfined water in the overlying shallow deposits.

Comprehensive analyses are not available to show the chemical character of native waters in the Gap—contamination of the “50-foot gravel” had started before extensive sampling of well waters was begun. The available analyses indicate that the dissolved solids have increased to about 1,000 to 1,500 ppm in recent years.

Inland from the Inglewood fault, well 2/14-5D9 (Southern California Water Co., Sentney plant, well 9) taps the full thickness of the “50-foot gravel.” That well in 1940 yielded calcium, sodium bicarbonate water containing 747 ppm of dissolved solids. In 1945 it yielded a calcium sulfate, bicarbonate water whose dissolved solids had increased to 958 ppm.

Inland from Ballona Gap, well 2/14-1M1, 80 feet deep, yielded water in 1935 containing 27 ppm of chloride, showing that at least locally the water from the “50-foot gravel” was then as low in chloride as that from deeper aquifers.

#### WATERS IN RANGE 3 (UNNAMED UPPER PLEISTOCENE DEPOSITS)

Within the west basin the chemical character of waters in the unnamed upper Pleistocene deposits is known almost wholly from analyses of waters from wells tapping the “200-foot sand” or correlative extensions in the Torrance-Inglewood subarea (pl. 18). Beneath the central part of the Torrance plain south of Rosecrans Avenue, under native conditions the “200-foot sand” yielded water in which the dissolved solids ranged about from 300 to 500 ppm and which was of the calcium, sodium bicarbonate type. Analyses made since 1929 (particularly chloride determinations by the Geological Survey for 1944-45) show that the chloride content of these native waters ranges about from 50 to 90 ppm. The upper limit here placed on their chloride content may be too low; water from two wells (3/14-22R2 and 26Q3) in 1943 contained 155 and 121 ppm of chloride, respectively (table 29), and dissolved solids were less than 600 ppm, according to determinations of electrical conductivity. However, data showing these to be native waters are lacking, and the chloride content may have been increased by local contamination. On the other hand, in sec. 26, T. 3 S., R. 14 W., the chloride content of waters taken in 1944-45 from wells tapping the unnamed upper Pleistocene deposits is as low as 22 ppm (table 29, wells 3/14-25N3, 26P1, and 26Q5).

North of Rosecrans Avenue, and especially in the area between Hawthorne and Inglewood, the unnamed upper Pleistocene deposits contain water in which the dissolved solids range about from 500 to 700 ppm and the chloride from 125 to at least 250 ppm. Analyses are not available to define the character of these waters closely, chiefly because wells tapping the unnamed deposits for which an-

Analyses are available also tap the underlying San Pedro formation. However, these waters are of native inferior character.

Southeast of Gardena, in sec. 31, T. 3 S., R. 13 W., the unnamed upper Pleistocene deposits now (1948) contain water which probably is contaminated locally. Under native conditions these deposits yielded water ranging in dissolved solids from 400 to 500 ppm (pl. 17). Analyses of water samples collected periodically by the Geological Survey in 1941-42 from wells in sec. 31 suggest that confined water in these unnamed upper Pleistocene deposits may contain somewhat more than 500 ppm of dissolved solids locally; also, they suggest an increase in salinity during that period in certain wells tapping these deposits (Piper, Garrett, and others, 1953, p. 264).

To the south, about in sec. 19, T. 4 S., R. 13 W., the unnamed upper Pleistocene deposits yield water in which the chloride content (based on water samples from 2 wells, each 180 feet deep) is about 25 ppm and the dissolved solids content is about 300 ppm. Here the water from that depth is of excellent quality and is considered free of contamination. However, water from wells not more than 100 feet deep—inferred to tap the upper part of the unnamed deposits—is of poorer quality. In 1941-42 that water ranged from 62 to 409 ppm in chloride content and from 350 to 1,050 ppm in dissolved solids. Waters of both poor and good quality in sec. 19 are believed to be native, however.

#### WATERS IN RANGE 5 (UPPER PART OF THE SAN PEDRO FORMATION)

In the west basin, the character of waters from range 5 (the upper part of the San Pedro formation) is known only from data of wells tapping the "400-foot gravel" in the synclinal trough beneath the Torrance plain. Analyses are available for four wells in T. 3 S., R. 14 W., and for one well in T. 2 S., R. 14 W., all of which tap only the "400-foot gravel." Of these five analyses, three are for waters considered representative for the "400-foot gravel." These are 3/14-10C1, analysis of August 21, 1945; 3/14-15G1, analysis of 1940; and 3/14-23L1, analysis of December 5, 1940 (table 30 and pl. 19). In these analyses the dissolved solids range from 323 to 359 ppm; from north to south, the ratio of calcium to other bases increases somewhat, with a corresponding decrease in the ratio of bicarbonate to other acid radicals. Also from north to south, chloride decreases from 38 to 28 ppm, and sulfate increases from 42 to 69 ppm. The content of 69 ppm of sulfate at well 23L1—the southernmost of the three—marks that water as being different from the water in the underlying Silverado water-bearing zone, which here contains less than 34 ppm of sulfate. The other two analyses do not conform to the regional character as described. For example, well 3/14-15D1 yields a water

definitely poorer in quality than the type water. In 1930 this well yielded a calcium, sodium chloride water in which the dissolved solids and chloride content were 576 and 198 ppm, respectively. This water has about the same amount of dissolved solids as that known to occur in the overlying unnamed upper Pleistocene deposits west of Hawthorne. Thus, analysis 3/14-15D1 probably represents a blend of waters from the "400-foot gravel" and from the unnamed deposits above.

In Ballona Gap, east of the Inglewood fault, the upper part of the San Pedro formation is tapped by several wells at the Sentney plant of the Southern California Water Co. (wells 2/14-5D5, 5D7, and 5D10); also by several public-supply wells of the city of Beverly Hills (wells 32M3 and 32K1). Chemical analyses are available for these wells. As shown on figure 14 and as discussed on pages 210-212, the character of these waters has varied between wide limits; however, as there explained, this fluctuation presumably does not represent a trend toward contamination but probably results from the blending with inferior native waters that existed in sec. 32. The waters were initially sodium bicarbonate waters; later analyses show a slight trend toward sodium, calcium bicarbonate waters. Chloride ranges generally from 62 to 173 ppm.

WATERS IN RANGE 6 (MIDDLE AND LOWER PARTS OF THE SAN PEDRO FORMATION)

Throughout its known extent in the west basin, except near the coast and locally elsewhere, the Silverado water-bearing zone of the middle and lower parts of the San Pedro formation yields native waters of excellent quality (pl. 19). These range from sodium, calcium bicarbonate to sodium bicarbonate waters.

In the southeastern part of the west basin, in and near Dominguez Gap, wells tapping the Silverado water-bearing zone yield sodium bicarbonate water, in which the dissolved solids range from 210 to 250 ppm, the hardness generally ranges from 70 to 85 ppm, and the chloride content is about 25 ppm. From east to west across Dominguez Gap, the sulfate seems to diminish; at well 4/13-14Q4 the sulfate content is about 35 ppm, and at well 21Q1 it is negligible. In Dominguez Gap most of the waters selected as representative of the Silverado water-bearing zone, as shown on plate 19, are from the upper or central parts of the zone. These waters are similar in hardness content to waters from wells tapping the upper part of the Silverado zone northeast of the Signal Hill uplift, where they range in hardness about from 66 to 91 ppm; those from the lower part of the Silverado zone range in hardness about from 15 to 28 ppm.

Along the northeast flank of Palos Verdes Hills in T. 4 S., R. 14 W., and in the southwest corner of T. 4 S., R. 13 W., the

Silverado water-bearing zone contains waters markedly different from those in the same zone beneath Dominguez Gap.

These markedly different waters are essentially sodium bicarbonate waters in which the bicarbonate is as high as 389 ppm; they differ from typical Silverado waters to the north and to the northeast in that (1) their sodium content is somewhat in excess of 100 ppm and (2) their chloride content commonly ranges from 50 to 75 ppm higher than that of the typical Silverado waters. The chloride is as high as 129 ppm (4/14-35E2) and sulfate commonly is less than 3 ppm. The high chloride content of these waters doubtless is due to blending with connate sodium chloride water occurring locally in the Silverado water-bearing zone beneath the flank of the Palos Verdes Hills (Piper, Garrett, and others, 1953, p. 57-58, and p. 230 analyses for well 5/13-6D1). This connate water is considered native, but since its inclusion with marine sediments it has been modified by the usual processes of base exchange and sulfate reduction, and, in addition, it has been diluted by land-derived waters. Analyses of water from well 5/13-6D1 are typical of this diluted connate water; the chloride and dissolved solids content are about 450 and 1,200 ppm, respectively. To the north, the effect of blending with this connate water does not extend more than about half a mile; wells 4/13-30K1 and 4/14-16L3, each about three-quarters of a mile northeast of the Palos Verdes Hills, yield water containing only 24 ppm of chloride. To the east, water from wells 4/13-31E3 and E4 shows the effect of blending with the connate water, although such blending has not been particularly deleterious; the chloride content of water from both wells in 1932 was less than 70 ppm. To the southeast, the extent of the connate water is not known, but evidence from electric logs of oil wells suggests that it may underlie the eastern part of Terminal Island.

In the west basin northwest of Dominguez Gap and extending about to Inglewood—that is, through the known extent of the Silverado water-bearing zone—the waters are consistently harder and higher in proportion of calcium and magnesium among the bases than those from this zone in Dominguez Gap. For example, the hardness ranges about from 100 to 275 ppm; north of Rosecrans Avenue, it is commonly more than 200 ppm. In these sodium, calcium bicarbonate waters the dissolved solids range about from 250 to 500 ppm but commonly are about 300 to 350 ppm. Across this central part of the west basin, from northeast to southwest—that is, from the crest of the Newport-Inglewood uplift to the coast—certain trends in chemical character are suggested by available data. These trends are as follows:

1. Near, but coastward, from the crest of the Newport-Inglewood uplift, the sulfate in the Silverado waters is at least 30 ppm. Westward, the sulfate di-

minishes rapidly and becomes low or negligible at the axis of the syncline; in general, it remains small or negligible to the coast.

2. Near, but coastward from the crest of the Newport-Inglewood uplift, the chloride content of the Silverado waters is probably not more than 36 ppm. This chloride content is reasonably constant to within about 2 miles of the coast; under native conditions it increased to about 90 ppm at the coast.

Adjacent to the coast, from the Ballona escarpment to and beyond Redondo Beach, native water no longer occurs in the Silverado water-bearing zone; as of 1946 this coastal strip was moderately to intensely contaminated. The chemical features of this contamination, and minor lateral differences in native waters found here initially will be discussed later.

Inland for 2 miles or more from the crest of the Newport-Inglewood uplift, from Dominguez Hill on the south to near Inglewood on the north, wells tapping the Silverado water-bearing zone yield water characteristically different from that in the central part of the west basin. As shown by analyses of water from wells 3/13-6G1, 3/13-8L2, and 3/14-1G1 (table 30), these are predominantly calcium bicarbonate waters; they differ chiefly in chloride and sulfate content from those waters coastward from the Newport-Inglewood uplift. In these waters, chloride is about 26 ppm and sulfate about 75 ppm.

Beyond the known extent of the Silverado zone (pl. 19), waters of excellent quality occur in the middle and lower parts of the San Pedro formation correlative with it. Analyses of water from well 2/14-22P1 at Inglewood, from wells 2/14-4N1 and 5D6, north of the Baldwin Hills, and from well 2/14-14C2, east of the Baldwin Hills, are representative. These wells contain calcium bicarbonate to sodium bicarbonate waters; their range in constituents and character may be determined from table 30, plate 19, and from table 16.

In sec. 5, T. 2 S., R. 14 W., available analyses indicate that water in the lower and middle parts of the San Pedro formation is sodium bicarbonate water and possibly is of somewhat better quality than that from the upper part of the formation (fig. 14).

In the Ballona Gap, about from the Inglewood fault to the coast, native waters in the San Pedro formation range from calcium, sodium bicarbonate to calcium bicarbonate waters. They contain about 40 to 70 ppm of chloride (usually about 60 ppm), nearly 100 ppm, and locally more than 200 ppm of sulfate, and about 480 to 650 ppm of dissolved solids. Thus, compared to waters inland from the Inglewood fault, their content of dissolved solids is higher than in the waters in the middle and lower parts of the San Pedro formation to the east. Also, they differ in character from the waters in the San Pedro formation yielded to wells just south of the Ballona escarpment (pl. 19, also p. 215). Native waters from wells 2/15-11J1 and 23P1



in Ballona Gap were anomalous in character (as compared to the type waters in the gap) but were roughly similar to the waters south of the escarpment; this fact suggests some blending of the two types of water.

As of 1946, in the coastal part of the gap the waters in both the San Pedro formation and the overlying "50-foot gravel" of Recent age were contaminated; the extent and degree of contamination will be discussed later.

In the area just south of the Ballona escarpment, about in secs. 26 and 34, T. 2 S., R. 15 W., analytical data suggest that the waters under native conditions generally ranged from 80 to 100 ppm of chloride, from 30 to 50 ppm of sulfate (but usually less than 40 ppm) and from 500 to 600 ppm of dissolved solids. They were sodium bicarbonate to sodium, calcium bicarbonate waters and are represented by analyses of water from wells 2/15-26B1, 34A1, 34H1, and 34K1 (table 30: well 26B1, Mar. 29, 1932; well 34A1, Nov. 18, 1929; well 34H1, Jan. 8, 1930). Their chemical character is shown by figure 11, which compares them to representative waters of the San Pedro formation in Ballona Gap. (See also discussion of contamination at Playa del Rey.)

#### WATERS OF THE UNDIFFERENTIATED PLEISTOCENE DEPOSITS

To the north of Ballona Gap, and particularly beyond the north limit of T. 2 S., water-bearing zones are so discontinuous that a regional stratigraphic correlation has not been made (p. 45). Here, as may be expected, the waters from these several zones range considerably in quality and show striking local differences in character. Nevertheless, the over-all range in character is not markedly greater than that of the waters in the San Pedro formation immediately to the south in Ballona Gap. This also is to be expected because of the presumed hydraulic continuity with those deposits. Analyses of waters from wells 1/14-19R1, 1/14-20M1, 1/15-28B2, and 32A1 are believed to illustrate the range in chemical character of these waters (table 30 and pl. 19).

Typical of water from wells tapping the undifferentiated Pleistocene deposits is a nonsystematic fluctuation of dissolved solids, particularly chloride, in recurrent analyses for any given well over a period of several years. The chloride content in these waters ranges from 40 to 268 ppm and the sulfate content ranges about from 5 to 212 ppm. They range from calcium bicarbonate to sodium bicarbonate waters. Definite evidence of local contamination in these deposits cannot be proved because of the great range in proportion of individual constituents and because of the great range of dissolved solids as a whole. However, definitely inferior waters in these Pleistocene

deposits may be derived through upward movement from the underlying Pliocene rocks.

WATERS IN RANGE 7 (UPPER DIVISION OF PICO FORMATION)

For the Torrance-Santa Monica area, information on the chemical quality of water from the upper division of the Pico formation is obtained from analyses of water from six widely separated wells—1/15-25C1, 2/14-27J1, 2/15-1C5, 3/14-17J1, 4/13-12A2, and 5/13-3H. (See table 30 and pl. 19.) Three of the analyses (3/14-17J1, 4/13-12A2, and 5/13-3H) are from wells in or near the Torrance-Inglewood subarea. In these the dissolved solids range from 452 to 750 ppm, the chloride from 52 to 130 ppm, and the bicarbonate from 413 to 487 ppm. All are sodium bicarbonate waters. For the three the average percent sodium is 83. Thus, these are potable waters, although they are not desirable for irrigation because of their high percent sodium. In well 4/13-12A2 (city of Long Beach, North Long Beach well 6) the water was dark brown and the temperature was about 104°F. Although color and temperature could have been reduced by treatment, the yield of the well was considered too low to make treatment economical and the well was abandoned.

Of the other three analyses, one is from a well in the eastern part of Inglewood (2/14-27J1) and the others are from wells north of Ballona Gap, which are inferred to tap the upper division of the Pico formation or correlative deposits. In these the total solids range from 1,225 to 2,663 ppm, the chloride from 66 to 1,363 ppm, and the bicarbonate from 396 to 1,266 ppm. All these waters are unfit for ordinary uses.

Thus, available analytical data suggest that the waters in the upper division of the Pico formation north of Inglewood are saline and unusable; however, south of Inglewood, locally at least, they are of a quality suitable for some uses, although they may require treatment.

In the descriptions of native waters in the water-bearing zones of the Torrance-Santa Monica area of Recent and Pleistocene age, the silica content of the waters was not discussed because it does not appear to be a distinctive characteristic of any of the several ranges. The silica content of these waters was from 10 to 30 ppm, commonly less than 20 ppm. However, of the analyses of waters from the upper division of the Pico formation, four analyses indicate a considerably higher silica content, ranging from 35 to 59 ppm. Because of this greater concentration in the waters of the upper Pico, silica might be used as a diagnostic constituent in a critical study dealing with blended native waters yielded from wells tapping both the upper division of the Pico formation and the overlying water-bearing zones.

## WATERS AT THE CENTINELA PARK WELL FIELD OF THE CITY OF INGLEWOOD

At the Centinela Park well field of the city of Inglewood, wells on opposite sides of the Potrero fault yield water with marked differences in chemical character. Elsewhere along the faults of the uplift, at least south to Dominguez Gap, differences are minor. Hydrologic information shows conclusively that the fault here is a substantial hydraulic barrier. Chemical evidence confirms the existence of that barrier. At this well field, seven wells were sampled in 1944-45 by the Geological Survey. Of the wells so sampled, five were east of (inland from) the Potrero fault and two were west of it. Inland from the fault, the chloride content of the water ranged from 25 to 56 ppm; coastward from the fault but adjacent to it, the chloride content ranged from 121 to 156 ppm. (For type analyses, see wells 2/14-22N3 and 2/14-27D3, table 30.) Inland from the fault, the waters are calcium bicarbonate in character and the dissolved-solids content is about 375 ppm. To the west, across the fault, well 2/14-27D3 also yields calcium bicarbonate water but the dissolved solids content is about 450 ppm. Although not cited here, chemical data from wells about a mile to the southwest, in sec. 28, T. 2 S., R. 14 W., suggest that the increase occurs chiefly in chloride and sulfate, with a proportionate increase in calcium and sodium. Only at well 28E1 (city of Inglewood well 23) is the increase in cations wholly in sodium. However, the character of water from this well probably is anomalous; transverse faulting south of the well may separate it from the others in sec. 28 for which chemical data are available.

At the Centinela field, both the "200-foot sand" and the water-bearing zones in the San Pedro formation are tapped by many of Inglewood's public-supply wells. However, water levels here are now (1948) at or below sea level and the "200-foot sand" is almost wholly dewatered; thus, in recent years the water has been withdrawn almost entirely from the San Pedro formation.

**POTENTIAL CONTAMINANTS OF FRESH-WATER BODIES IN THE TORRANCE-SANTA MONICA AREA**

Fresh waters in the Torrance-Santa Monica area, which have become contaminated, or which have received an increase in salinity, are a result of a mixture with certain waters, either moderately or excessively high in total solids. These latter waters have their source either outside the fresh-water zones, with migration into those zones after discharge at or near the land surface, or by establishment of favorable gradients through permeable deposits, or both, or inside the fresh-water zones, occupying either a part of a permeable zone stratigraphically equivalent to that containing the fresh water, or a con-

tiguous zone or zones that may be either younger or older than that containing fresh water, but requiring a suitable gradient and hydraulic continuity to advance into the fresh-water zone.

#### EXTERIOR CONTAMINANTS

Contaminants that initially are outside zones containing fresh water under native conditions and that require hydraulic continuity and a favorable gradient toward those zones in order to mingle with the fresh waters are: (1) ocean water, (2) industrial wastes, and (3) oil-field brines.

#### OCEAN WATER

As in the Long Beach-Santa Ana area, ocean water is an obvious potential contaminant in the Torrance-Santa Monica area because water-bearing zones, at places along the coast from Santa Monica to the Palos Verdes Hills and beneath San Pedro Bay, crop out on the ocean floor and are inferred to be in hydraulic continuity with the ocean; because certain areas, specifically the coastal parts of Dominguez and Ballona Gaps, have been or are now being overrun by ocean water within the tidal range; and because the water levels near the coast widely have been drawn down below sea level.

In the coastal part of Dominguez Gap, the original tidal flats have been filled in and dikes have been constructed along both the Los Angeles River and Dominguez Channel with the result that inland movement of tidal water is restricted to those water courses; in the Los Angeles River, the extreme inland reach of oceanic water during the highest tides is 0.95 mile or to a point about a quarter of a mile south of Anaheim Street. To the northwest in Ballona Gap, tidal marshes extend inland nearly to Lincoln Boulevard. In the old channel of Ballona Creek, the tidal range was about the same as in the adjacent marsh; in the new channel, completed early in 1938, the inland reach of tidal water is about to Inglewood Boulevard, 1 mile farther inland and about 3 miles from the coast.

To show the chemical character of ocean water, two analyses are given in table 31—a "standard" analysis and an analysis of water from San Pedro Bay. For these representative analyses, ocean water generally ranges from 34,100 to 34,500 ppm in solids, and from 18,400 to 19,000 ppm in chloride. Magnesium is about three times as abundant as calcium; however, in native ground waters, calcium is the more abundant. In ocean water, the bicarbonate content is about 140 ppm; in native ground waters, bicarbonate may be as great as 400 to 500 ppm, but normally it is about 250 to 300 ppm.

## INDUSTRIAL WASTES

Wastes discharged as a result of industrial activity become potential contaminants of fresh-water zones in the Torrance-Santa Monica area when (1) they are discharged into natural or artificial water courses that traverse that area, or (2) they are discharged at land surface in sumps and pits and are allowed to evaporate and seep away.

Four water courses traverse the Torrance-Santa Monica area. These are the Los Angeles River, Dominguez Channel, and Compton Creek, which are all in and near the Dominguez Gap, and Ballona Creek, in the Ballona Gap. The conditions of industrial-waste disposal in Dominguez Gap have been discussed at length in an earlier report (Piper, Garrett, and others, 1953, p. 80-83). Wastes discharged to the Los Angeles River inland from Dominguez Gap commonly are sodium chloride or sodium sulfate waters and in most cases are considerably less concentrated than oil-field brines. However, the analyses here cited suggest that in recent years, disposal of wastes into the Los Angeles River inland from Dominguez Gap has been carried on to a lesser degree than formerly.

Within the west basin, the chief point of disposal of waste to the Los Angeles River (in 1946) is just upstream from Wardlow Road. Here are the skimming sumps of the Oil Operators, Inc. From these sumps, oil-field brines have been discharged to the Los Angeles River at a rate that averaged 4.4 cfs from 1928 through 1943. These brines have ranged in chloride content from 9,000 to 16,000 ppm since 1932 and at times of low natural runoff the brines have made up the total flow of the river.

The Dominguez Channel is used for disposal of oil-field brines from the Dominguez and Rosecrans fields and of saline wastes from the several oil refineries in the industrial area west of Long Beach. As shown by analyses of water taken from Dominguez Channel by the Geological Survey in 1942-43, the water of the channel has ranged at least from 145 to 10,000 ppm of chloride throughout its reach southeast of Main Street to Wilmington Avenue. For at least a part of the time, the volume of wastes carried by the Dominguez Channel has been as much or more than that carried by the Los Angeles River.

Inland from the west basin, Compton Creek discharges to the Los Angeles River about 5.5 miles from the coast and 0.3 mile inland from the Cherry-Hill fault. In 1942-43 from analyses by the Geological Survey, the chloride content in the lower reach of Compton Creek ranged from 62 to 132 ppm. Although the indicated concentration is low, the creek carries organic material which makes the water very turbid and foul-smelling. For approximately the same period through which the water samples were taken, the mean flow in the creek was about 10 cfs; the minimum flow was 3 cfs.

Available chemical analyses for Ballona Creek suggest that, at least at times, the creek has received contributions of water of marked salinity. For instance, the highest chloride sample reported (4,354 ppm) was obtained in 1932 from a spring discharging from the northwest bank of Ballona Creek, 700 feet upstream from Higuera Street (in 2/14-5M). A comprehensive analysis was not made, hence the chemical nature of the saline water is not known. Most of the samples collected from the creek have contained only a few hundred parts of chloride. The lowest concentration known was for a sample taken from the creek February 11, 1936 by Dr. Carl Wilson; this sample had a chloride content of 15 ppm. A series of five analyses, two by Dr. Wilson in 1936 and three by the California Division of Water Resources in 1937-38, indicate that the streamflow then ranged in character from a sodium chloride water to a sodium, calcium bicarbonate water. None of the comprehensive analyses suggest additions of oil-field brines during that period; fluctuations in chloride content are accompanied by a corresponding change in sulfate content. If such chloride fluctuation had resulted from addition of oil-field brine, little or no change in sulfate would have occurred. Koch (1940, p. 18) reports that a sample taken in December 1939 from a small creek flowing into Ballona Creek from the Baldwin Hills (sampling point in 2/14-5N, about 100 feet north of Jefferson Boulevard) contained 2,630 ppm of chloride. This creek, according to the report, carries much of the surface runoff of the Inglewood oil field. However, the extent to which the Ballona Creek has been used as a means of disposal for oil-field brines is purely conjectural in the absence of analyses of creek flow showing such discharge.

From the early thirties to 1938, extensive sections of Ballona Creek were paved with concrete. As of 1938, the channel was paved with an impervious lining from Crenshaw Boulevard for about 4 miles downstream to LaSalle Avenue, which is about 0.75 mile upstream from the Overland Avenue fault (pl. 2). From LaSalle Avenue to the coast, about 5 miles, only the sides of the channel are paved (1946). The tidal reach now extends inland about 3.1 miles, or to Inglewood Boulevard. Thus, since 1938, it has been only in the 2-mile reach from LaSalle Avenue to Inglewood Boulevard that the channel bottom has been open to receive influent seepage from the creek discharge. This 2-mile reach spans the Charnock subbasin and the coastward 0.75-mile segment of the crestal subbasin. It is not known whether substantial seepage losses from the creek occur in this reach, but certainly a potential threat of contamination exists at such times as the creek carries water unfit for use. Coastward from Inglewood Boulevard, seepage contributions, if any, are from the saline tidal waters.

## OIL-FIELD BRINES

There are eight major oil fields in the Torrance-Santa Monica area—the Inglewood, Potrero, Rosecrans, and Dominguez fields along the Newport-Inglewood uplift and the Playa del Rey, El Segundo, Torrance, and Wilmington fields along the coast (pl. 18).<sup>14</sup> In addition, there are two minor fields—Lawndale and Beverly Hills—from which production is small. In all these fields most of the connate waters raised to the land surface are separated from the oil by settling or by mechanical or chemical dehydration. Analyses of the connate waters for four of these fields are given in table 31.<sup>15</sup> For the several oil fields, methods of brine disposal are described as completely as possible insofar as such information was made available to the Geological Survey.

*Yield of oil-field brines.*—The total amounts of brines pumped from the several oil fields in the Torrance-Santa Monica area are substantial. Table 17 shows the quantities of these brines discharged by each oil field for the year 1940, from records published by the California Division of Oil and Gas (1940-41, p. 28, 30).

TABLE 17.—Quantities of water produced from oil fields in the Torrance-Santa Monica area in 1940

[Data from publications of the California Division of Oil and Gas]

| Oil field          | Fluid yield (barrels) |               |
|--------------------|-----------------------|---------------|
|                    | Annual                | Daily average |
| Beverly Hills..... | 90, 141               | 247           |
| Inglewood.....     | 3, 705, 140           | 10, 150       |
| Potrero.....       | 337, 368              | 924           |
| Rosecrans.....     | 1, 556, 879           | 4, 265        |
| Dominguez.....     | 3, 291, 324           | 9, 017        |
| Playa del Rey..... | 3, 833, 257           | 10, 500       |
| El Segundo.....    | 1, 179, 636           | 3, 232        |
| Lawndale.....      | 79, 730               | 218           |
| Torrance.....      | 1, 695, 170           | 4, 644        |
| Wilmington.....    | 759, 856              | 2, 082        |

The total withdrawal of brines from these 10 fields in the Torrance-Santa Monica area as of 1940 was about 45,000 barrels a day or about 2,200 acre-feet a year, which is about 3 percent as great as the quantity of ground water pumped from the west basin alone in that same year.

*Inglewood field.*—The Inglewood oil field covers much of the Baldwin Hills north of Inglewood. The discovery well was completed late in 1924, and 150 productive wells had been drilled by September

<sup>14</sup> Two of the fields, Dominguez and Wilmington, are discussed at length by Piper, Garrett and others (1953, p. 70, 78) but those discussions will be briefed here.

<sup>15</sup> For analyses of connate waters from the Dominguez and Wilmington fields, see Piper and others (1953, table 29).

1925. The field has been developed almost entirely by the Kettleman and Inglewood Corp., Standard Oil Co. of California, Tidewater Associated Oil Co., Shell Oil Co., and the Texas Co. As of 1946, at least two companies, the Tidewater Associated Oil Co. and the Standard Oil Co. of California, ran the brines from their producing wells into settling ponds from which the overflow was piped chiefly to the city of Los Angeles Hyperion outfall sewer, which follows the north flank of Baldwin Hills and the south edge of Ballona Gap to the ocean. A part of the Standard Oil Co. waste water reportedly is discharged (1946) to Ballona Creek about half a mile upstream from Lincoln Boulevard, or well within the tidal reach. As of 1946, the Tidewater Associated Oil Co. discharged about 2,650,000 gallons of waste fluid each month. Although none of the brines from the Inglewood field are known to have been discharged to Ballona Creek above tidewater as of 1946, the analysis of the flow of a small stream from the north slope of Baldwin Hills (sampled in 1939 with a chloride content of 2,630 ppm) suggests that at least a diluted connate water was then discharged at land surface

*Potrero field.*—The Potrero field, east of Inglewood, was discovered in 1927, and by mid-1941 about 26 wells were in production. It is reported that, in the early thirties, the brines either were diverted into unlined ditches and sumps where they drained to the southwest, or they were hauled to a dump in Centinela Creek within the city of Inglewood until a city ordinance was passed to prohibit such practice. As of 1946 most of the production has been from wells of the Basin Oil Co., and waste brines are discharged to the Los Angeles County Sanitation District sewer system.

*Rosecrans field.*—This field occupies the west-central part of T. 3 S., R. 13 W., about 2 miles west of Compton. The chief operators in the field are the Union Oil Co. and the Barnsdall Oil Co. The Union Oil Co. carries (1946) the oil with its admixed brine from each well to a central dehydrating system. From there, the brine is pumped to a skimming pond near the intersection of Rosecrans Avenue and Main Street. This pond is used by the several companies operating in the field. The effluent from this pond reportedly is piped to a Los Angeles County sewer line. Of the total quantity so disposed, the Union Oil Co. in 1946 reportedly contributed about 57,000 barrels a month.

*Dominguez field.*—The Dominguez oil field was discovered in 1923 and has been developed largely by the Shell Oil Co. and the Union Oil Co. Since about 1930, at least a part of the waste fluids from the oil wells in this field have been piped to the plant of the Deepwater Chemical Co. for extraction of iodine. This plant is about 0.1 mile north and 1 mile west of the intersection of Wilmington Avenue and



Victoria Street, on the northwest flank of Dominguez Hill. The effluent from the plant is piped (1946) to an outfall on the Dominguez Channel about 0.4 mile northwest of Avalon Boulevard. When the plant is idle, the brines are piped to the Dominguez Channel through the same line.

Other means of disposal of brines formerly were employed by at least one of the operating companies (Piper, Garrett, and others, 1953, p. 70). In 1932, the Shell Oil Co. reportedly released brines into a ravine high on the southwest flank of Dominguez Hill and into the crater of a blown-out oil well near the crest of Dominguez Hill, just west of Wilmington Avenue and about 0.3 mile south of Victoria Street. It is understood that this practice was discontinued late in 1932. The quantity of brine so discharged at the land surface is not known, but if such disposal had been practiced since 1923, several hundred acre-feet of waste brine could have percolated to permeable deposits formerly saturated with fresh water.

*Playa del Rey field.*—This field is divided into two areas: (1) The ocean front or Venice area, along the coastal front of Ballona Gap, which was discovered in 1929; and (2) the Del Rey Hills area, almost wholly in sec. 27, T. 2 S., R. 15 W., which was discovered in 1931. In the Venice area, the brines from wells operated by the Union, Ohio, and Barnsdall Oil companies are piped to a plant operated by the Dow Chemical Co. for extraction of iodine. As of 1946, about 460,000 gpd was treated. The effluent from the plant is piped to a canal which is open to tidewater a short distance north of the plant. The brine treated by the plant constitutes almost the total water production of the field, although locally small amounts of brine may be discharged at land surface and allowed to drain away. The area occupied by this field is or has been overrun by tidal water of salinity equal to or greater than that of the connate brines.

In the Del Rey Hills part of the field, the brines are collected from the individual wells and then are piped into the city of Los Angeles Hyperion outfall sewer.

*El Segundo field.*—The El Segundo field, which is just east of the city of El Segundo, was discovered in August 1935 and was completely developed by late 1938. Waste fluids from wells east and southeast of El Segundo are piped (1946) to a main disposal line that crosses Sepulveda Boulevard at El Segundo Boulevard. Waste fluids from active wells in a minor producing area within the city of El Segundo, south of the city's water-treatment plant at Holly Avenue and Maryland Street, are conveyed to this line through a pipe running south on Center Street. The main disposal line runs west along El Segundo Boulevard, thence to the Standard Oil Co. refinery where, presumably, the brine is discharged to the ocean.

*Torrance field.*—The Torrance field is about 7.5 miles long; it reaches nearly to the Wilmington field on the east and to within about a mile of the coast on the west. The first productive well was completed in 1922, and peak production was reached in 1924. As of mid-1941, most of the production was from the southeastern part of the field.

From investigation of means of brine disposal in this field, it appears that (1946) many of the smaller companies discharge the brines from their wells to small sumps—usually one for each well—from which the brines evaporate or seep away. For the southeastern part of the field, brines from about 300 acres each of the Superior Oil Co. and of the Standard Oil Co. are piped to a skimming pond, about 1,500 feet east of Normandie Avenue and 0.9 mile south of Sepulveda Boulevard. From the pond, the brines are piped to the Los Angeles County sewer farm, which is between Vermont Avenue and Figueroa Street and about 0.8 mile south of Sepulveda Boulevard. In 1946, about 20,000 gpd of waste fluids were discharged to the sewer farm. Previous to about 1940, the fluids were conveyed from the skimming sump to the sewer farm by an open ditch. A large sump, just southwest of the intersection of Hawthorne Avenue and Torrance Boulevard, is reported to be used for disposal of waste fluids from wells of the Del Amo Estate Co.; from this sump, the fluids reportedly are allowed to evaporate or seep away. Disposal methods of waste fluids from the western part of the field are not known.

Thus, in the Torrance field it is possible that at least several hundred acre-feet of saline brines have passed from the land surface into the ground-water bodies, although only in sec. 9, T. 4 S., R. 14 W., are they inferred to have reached deposits tapped by an active water well.

*Wilmington field.*—The Wilmington oil field is west of the Los Angeles River and extends inland for a distance of about a mile to 3 miles from the Cerritos Channel and the innermost basins of the Los Angeles harbor. The first well of commercial importance was drilled here late in 1936. By the early forties, more than 900 wells were in production. At least three of the principal operators pipe their brines directly to tidewater (1946). However, many operators reportedly discharge brine into sumps or at land surface. Such disposal is of no serious consequence in the eastern two-thirds of the field, because that area now is underlain at shallow depth by contaminated waters which are no longer used. In the western third of the field, however, water wells not more than 75 feet deep yielded water of fair quality in the early forties; hence, in this western area, these brines are a potential contaminant, not only of the shallow water-bearing zones but also of the underlying Silverado water-bearing zone, by passage from the shallow zones through defective

---

## 192 GEOLOGY, HYDROLOGY, TORRANCE-SANTA MONICA AREA

well casings, or by slow downward movement through intervening deposits that are not wholly impermeable.

### INTERIOR CONTAMINANTS

The native interior contaminants in the Torrance-Santa Monica area are chiefly those inferior waters that have been described earlier. These include:

1. Unconfined and semiperched waters in the Dominguez and Ballona Gaps and beneath the Torrance plain. Locally in the gaps these contain as much as several thousand ppm of dissolved solids; their concentration probably has been increased both by contamination and by evaporation. Beneath the Torrance plain the dissolved-solids content of the unconfined waters ranges from 1,000 to 4,000 ppm.

2. Waters in the southernmost reach of the Gaspur water-bearing zone in Dominguez Gap. Here, this water-bearing zone has been extensively invaded by exterior contaminants; it, in turn, can contaminate deeper water-bearing zones now containing water of good quality.

3. Native connate or diluted connate water confined in the San Pedro formation adjacent to or underlying the northeast and east flanks of the Palos Verdes Hills. This is sodium chloride water and locally, at least, contains 1,200 ppm of dissolved solids.

Of the three sources, the first and second are the most critical. Wells tapping underlying aquifers must pass through these two, and where the inferior shallow water has a higher head than the deeper water of good quality, downward circulation will occur if well casings are defective. Both in Dominguez Gap and beneath the Torrance plain, water levels in underlying zones are several tens of feet below levels in the inferior water bodies above.

### CONTAMINATION OF THE NATIVE FRESH WATERS

#### GENERAL EXTENT OF WATER-QUALITY DEPRECIATION

As stated earlier, a few wells near the coast began to yield salty water in the late twenties. Subsequently, many of these wells were abandoned because contamination became so intense that the water could no longer be used. On plate 16 are shown the districts in the Torrance-Santa Monica area in which one or more of the ground-water bodies contained more than about 100 ppm of chloride in 1945-46. In certain of the districts, inferior waters existed under native conditions. In the Ballona and Dominguez Gaps, and along the coast from Playa del Rey to the Palos Verdes Hills, however, the extent of waters containing more than 100 ppm of chloride has resulted largely from saline contamination in the last 20 years, primarily from exterior sources. The inland advance of contamination along the coast since 1931-32 is indicated on plate 16 by the change in the position of the line showing 100 ppm of chloride.

**MODIFICATIONS IN CHEMICAL CHARACTER OF CONTAMINATED WATERS**

For both the Torrance-Santa Monica area and the Long Beach-Santa Ana area, contaminated waters are, almost without exception, not a simple blend of a native and a saline water. Instead, chemical reactions have occurred either concurrently with, or subsequent to, blending with the contaminant to the extent that the nature of the contaminant is completely or substantially disguised. Most commonly, these reactions involve (1) base exchange and (2) sulfate reduction.

1. For many of the contaminated waters in the Torrance-Santa Monica area, successive analyses of water from a given well during its period of active contamination show a definite increase in calcium along with the customary increase in chloride. Hence, these analyses might erroneously be taken as evidence to show blending with a calcium-chloride contaminant. However, no contaminant has been known to exist in the Torrance-Santa Monica area in which calcium predominates as an alkali radical. Therefore, this calcium enrichment, resulting from blending with a contaminant in most cases known to predominate in sodium among the bases, must be due to a modification in the ratios of calcium, magnesium, and sodium to each other. This modification is known as base exchange.

The fact that the base exchange process goes on extensively has become well-established. It can occur because the zeolite and glauconite minerals and certain clay-forming minerals have the property of holding the bases (calcium, magnesium, sodium, and potassium) loosely and in variable proportions. In the presence of a natural water, with whose chemical composition it is not in equilibrium, any of these particular minerals (and possibly some types of organic matter associated with sedimentary deposits) has the property of releasing to the water a part of the base or bases most loosely held and of absorbing from the water an equivalent amount of the base or bases for which it has a stronger bond. This process of exchanging bases goes on until an equilibrium is reached between the proportions of the several bases in the mineral and in the water, or until the exchangeable bases are exhausted in one or the other. With respect to the chemical character of the water, the effect is an increase in one or more bases and an ion-for-ion decrease in one or more of the remaining bases. Thus, if a sediment in equilibrium with a calcium bicarbonate water be subjected to contact with a water in which sodium predominates among the bases, a part of that sodium will be removed and will be replaced by calcium and to a smaller extent by magnesium in an ion-for-ion proportion. Hence, from this base-exchange phenomenon may arise the illusion that a calcium-rich contaminant has invaded the aquifer.

2. In both the Long Beach-Santa Ana area and the Torrance-Santa Monica area, many of the waters known to be contaminated by ocean water contain less sulfate than would result from a simple mixture of native water and the ocean water in the proportions indicated by the total amount of chloride present. This sulfate removal probably is due to the reduction of sulfate to sulfide, either by the action of anaerobic bacteria or by the action of organic material, with the concurrent production of  $\text{CO}_2$  in either case, which would increase the bicarbonate content of the water. In brines associated with petroleum, chemical analyses show the sulfate content to be low or zero, doubtless because the hydrocarbons have reacted with the sulfate and have resulted in the formation of hydrogen sulfide; the hydrocarbons in turn are oxidized to form carbon dioxide and water.

For a more complete discussion of these phenomena and for a bibliography relating thereto, reference should be made to the report on chemical character of waters in the Long Beach-Santa Ana area (Piper, Garrett, and others, 1953, p. 85-91).

#### CONTAMINATION IN BALLONA GAP

##### SUMMARY OF NATIVE WATER QUALITY

The geologic conditions in Ballona Gap and the hydraulic relations between the "50-foot gravel" and the underlying San Pedro formation have been summarized on pages 94 to 98. It is inferred that the difference in chemical character between waters yielded from the "50-foot gravel" and from the San Pedro formation was not great under native conditions. Water from wells tapping the "50-foot gravel" ranged about from 650 to 750 ppm of dissolved solids, although local wells presumably tapping the "50-foot gravel" yielded water containing at least 850 ppm of dissolved solids. Data concerning the chemical quality of water from wells tapping the San Pedro formation are fragmentary; the dissolved solids content probably ranged about from 480 to 650 ppm, although locally it was probably nearly as great as in the "50-foot gravel." These data represent the conditions as of 1903-4 and are based on determinations of electrical conductance of water from the wells sampled.

Chemical analyses of samples taken since about 1929 suggest that—at least for the period preceding that of extensive contamination—wells within Ballona Gap, tapping the "50-foot gravel" or underlying zones, yielded water markedly different from that yielded by wells tapping the San Pedro formation just south of the Ballona escarpment. In Ballona Gap, the waters contained from 40 to 70 ppm of chloride (the higher part of the range is confined to the shallower deposits), and nearly 100 to more than 200 ppm of sulfate. South of the Ballona escarpment, particularly in secs. 26 and 34, T. 2 S., R. 14 W., native water contained 80 to about 100 ppm of chloride and usually less than 40 ppm of sulfate. Figure 10 compares the chemical character of native or only incipiently contaminated waters in Ballona Gap to those immediately south of the Ballona escarpment. The principles of the procedure in plotting chemical character of waters on a so-called trilinear diagram have been described by Piper (1945). Also, figure 9 explains the chemical character of waters in the Torrance-Santa Monica area relative to their plotted positions on the diagram. On figure 10 the waters from Ballona Gap and from the area south of the gap plot in two separate fields, chiefly because of the difference in ratio of calcium and magnesium to sodium, and of bicarbonate to sulfate.

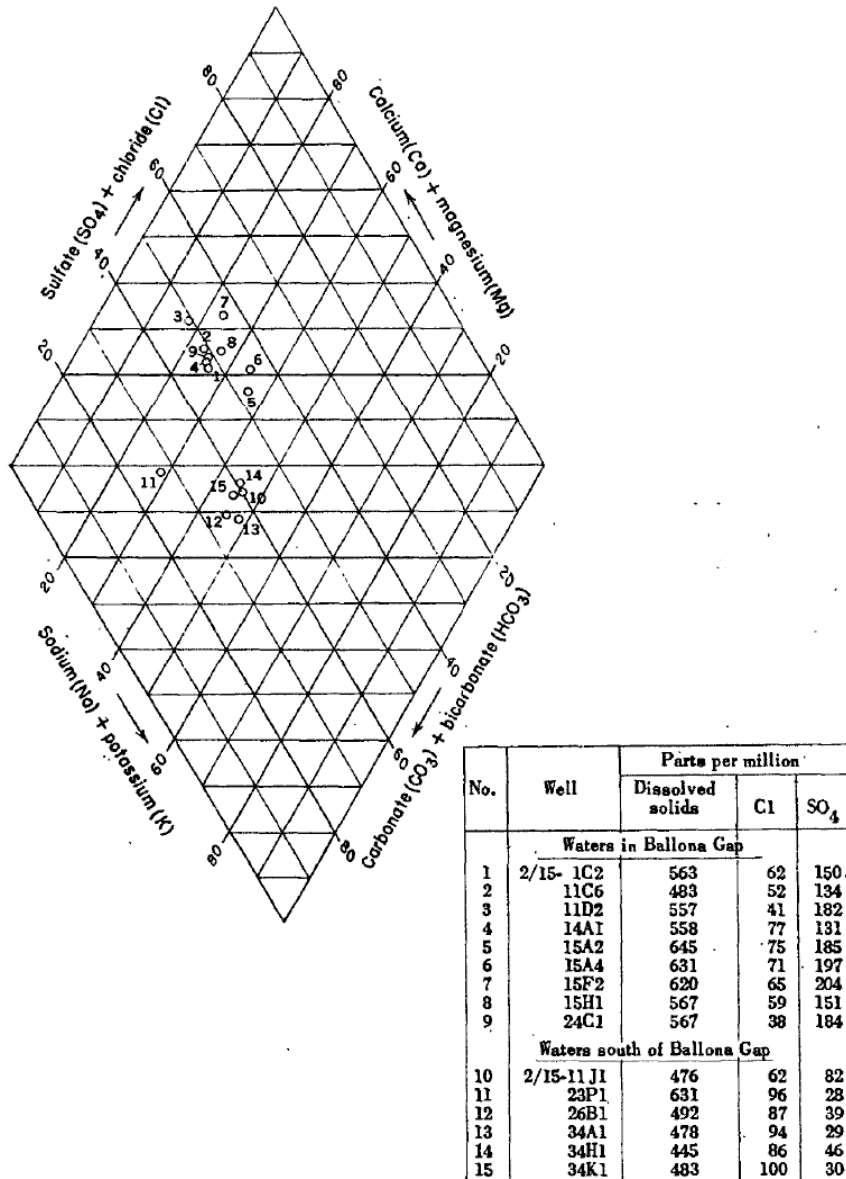

FIGURE 10.—Chemical character of selected native waters in Ballona Gap compared to waters just south of the Ballona escarpment.

However, this distinction in water character is not universal. For example, two wells in the gap, 2/15-11J1 and 23P1, in 1930-31 yielded water somewhat similar to that from wells tapping the San Pedro formation immediately south of the Ballona escarpment. The water in well 2/15-23P1 may represent a blend with a northward-extending lobe of the waters occurring south of the escarpment; it is difficult, however, to see how such a blend could have reached well 11J1 without appearing first in wells 2/15-24C1 and 14A1 (pl. 19). Thus, the chemical evidence here presented suggests that under native conditions, little, if any, water moved from the gap to the deposits south of the escarpment, or vice versa. Although the type native waters selected from secs. 26 and 34, T. 2 S., R. 15 W., are sodium, calcium bicarbonate waters, the analyses of water from wells 2/15-34A1 and 34K1 (table 30) suggest that, at least part of the time, sodium bicarbonate waters were present locally.

On the west flank of Baldwin Hills, well 2/14-18F1 in 1925 yielded water containing 182 ppm of chloride, 143 ppm of sulfate, and 823 ppm of dissolved solids. This water is probably a native blend in which waters from pre-Pleistocene deposits have moved into the San Pedro formation and are tapped by that well. The analysis represents a water similar to, but less concentrated than that from well 5/14-12C1 (table 30), on the east flank of the Palos Verdes Hills; this well is believed to tap pre-Pleistocene deposits in an area presumed to be free of contamination from surface-disposed brines. Analyses of water from well 2/14-18F1 in 1932 and 1945 show definite contamination, in which oil-field brine doubtless has contributed most, although not all, of the observed salinity.

For the shallow unconfined waters in Ballona Gap, too few analyses have been made to gain definite knowledge of their chemical character, either under native conditions or during the development of contamination. However, under native conditions dissolved solids commonly ranged from 800 to 1,000 ppm, but locally they are inferred to have been as high as 5,000 ppm. For water from several wells tapping the unconfined body in secs. 22, 23, and 24, T. 2 S., R. 15 W., the chloride concentration in 1930-32 was about 200 to 400 ppm—not inordinately high for shallow unconfined waters near the coast. However, because the unconfined waters can be expected to differ markedly with local conditions, these analyses are of little value for determining the quality of the unconfined waters elsewhere within the gap. It is concluded that the native unconfined waters at shallow depth in Ballona Gap generally were somewhat inferior and locally were greatly inferior to the waters in the underlying aquifers of the principal water body.

## GENERAL FEATURES AND EXTENT OF CONTAMINATION

The study of the history and progress of contamination in Ballona Gap is complex and is rendered difficult for three reasons:

1. Before 1930 only a few comprehensive analyses of Ballona Gap waters were made. Because of this dearth of analyses, some locally native water types in the gap may have been considered in this report as definitely or incipiently contaminated.

2. Only locally in the areas of contamination has the salinity increase been sufficiently great to afford definitive knowledge of the chemical character or the source of the contaminant.

3. The directions in which contaminated waters and contaminants move within the gap are influenced locally by hydrologic barriers which transect the San Pedro formation but do not transect the "50-foot gravel" (p. 94). Therefore, the paths taken by the contaminated waters during the period of development to date (1946) have depended not only upon the hydraulic gradient and the amount of hydraulic connection between the "50-foot gravel" and the underlying water-bearing beds of the San Pedro formation, but they also depend upon the barrier partitions within that formation.

Since 1930 many active wells have been sampled periodically. Consequently, a large number of analyses are available for study for the period 1930-46, and much can be learned regarding the chemical character and contamination of the waters during this period.

Information is not available to indicate the time contamination began in Ballona Gap. As of 1930-32, however, waters containing more than 100 ppm of chloride occurred within the "50-foot gravel" or the underlying water-bearing deposits of the San Pedro formation beneath about 5,100 acres, or about 8 square miles, along the coast and extending inland to the vicinity of Sepulveda Boulevard (pl. 16). In this area, the chloride concentration then ranged from 100 to about 400 ppm, and the dissolved solids commonly ranged from 800 to 2,000 ppm. The extent of contamination between the Charnock and Overland Avenue faults as of 1930-32 is not known because analyses are not available. However, in the middle and late thirties, wells south of Ballona Creek in this block yielded water containing as much as 500 ppm of chloride (wells 2/15-13K2 and K4), and it is inferred that this area was contaminated as early as 1930-32.

At the north edge of the Baldwin Hills, and some 6 miles inland from the coast, chiefly in sec. 5, T. 2 S., R. 14 W., an area of about 250 acres was underlain by contaminated waters in 1930-32. Of six wells for which analytical data are available, the chloride content of five wells was in excess of 500 ppm and was 254 ppm in the sixth. The contamination extended northward beyond well 2/14-5F2 and southward beyond well 2/14-8D1. The greatest concentration was in well 5N1 (5,414 ppm of chloride). Fragmentary analytical data suggest that the waters were not contaminated between the coastal



and inland areas as of 1930-32, although native water containing more than 100 ppm of chloride existed along the west flank of the Baldwin Hills; this is shown by a chloride concentration of 182 ppm in well 2/14-18F2 in 1925.

As of 1946, nearly all of Ballona Gap coastward from the Overland Avenue fault was underlain by contaminated waters; this coastal area of contamination had extended to some 7,300 acres, or about 11.4 square miles, an increase of about 2,200 acres in 15 years (pl. 16). The movement of the saline front had been generally northward across the gap; coastward from the Charnock fault, it had advanced from 0.4 to 0.9 mile; inland between that fault and the Overland Avenue fault, it probably had advanced about 1 mile in the 15 years. As of 1946, essentially all the area coastward from Lincoln Boulevard was underlain by water with a chloride content greater than 500 ppm.

At the north edge of the Baldwin Hills, in sec. 5, T. 2 S., R. 14 W., the area of contamination probably remained about constant from 1930 into 1946, although its front may have moved northward because of the large withdrawals from the wells of the Southern California Water Co. and the city of Beverly Hills in 2/14-5C and 2/14-5D.

Between the coastal area of contamination and the area north of the Baldwin Hills, a third area of contamination developed on the west flank of the Hills in the thirties and early forties. By 1946, about 200 acres east of the intersection of Overland Avenue and Jefferson Boulevard was underlain by water containing more than 500 ppm of chloride (pl. 16). The focus of this contamination is presumed to be in the vicinity of well 2/14-7K1, because water from this well contained 18,810 ppm of chloride in 1939.

In contrast to the general contamination in the gap, an area about 0.15 mile wide and 0.8 mile long, inland from the Charnock fault and south of Ballona Creek, was still uncontaminated as of 1940—according to analyses of samples from wells 2/15-24C1 and 24F3. So far as known, the main water-bearing zone in this narrow strip then contained less than 60 ppm of chloride; as of 1945, it probably was no more than incipiently contaminated.

#### CONTAMINATION NEAR THE COAST

In the coastal area of contamination, saline encroachment presumably began in the twenties and abandonment of wells started about 1930. For example, two wells of the Venice Consumers Water Co. in sec. 16, T. 2 S., R. 15 W., about 1 mile from the ocean, were abandoned in 1930 because of salinity. Abandonment of wells at the Marine plant of the city of Santa Monica in 2/15-9N began about 1933, although at least one or two of the wells were used into 1941. In 1940, well 2/15-9N7 (well 5 of the city of Santa Monica) yielded

water containing over 1,100 ppm of chloride. For the interval from 1930 to 1945, sharp increases in salinity were restricted chiefly to wells within 1.5 to 2 miles of the coast. Records of chloride analyses for selected wells are plotted on plate 20 to show the rate of salinity increase in the coastal area of contamination in Ballona Gap. Analyses were made chiefly by Los Angeles County Flood Control District, California Division of Water Resources, and Los Angeles Department of Water and Power. In general, the chloride increase has been greatest in wells less than about 1.5 miles from the coast. Except for these badly contaminated wells, and some local wells not shown here, the graphs indicate that, for the area as a whole, salinity has not definitely increased since the middle thirties; in fact, many of the well waters have had a slight decrease in salinity in recent years. For this coastal area of contamination, chemical evidence does not suggest any regional quality gradient between the "50-foot gravel" and the San Pedro formation.

The information regarding the zones tapped is too meager to indicate whether any definite relation exists between depth of zone tapped and water quality. Tentatively it may be concluded that, at least for the coastal part of the gap, no uniform vertical gradation in quality exists. Therefore, the two water-bearing zones are not discussed separately in dealing with contamination here, but instead, they are treated as containing a single contaminated water body.

#### CHEMICAL FEATURES OF CONTAMINATION

In the coastal area of contamination many of the well waters have become grossly contaminated; in 1945, at least one well (2/15-22J1) yielded water in which the dissolved-solids content was more than 4,000 ppm. To show the manner in which chemical character of the contaminated waters has changed with increase in concentration, figure 11 is plotted to show a number of the more highly contaminated waters in order of increasing concentration. Also plotted on the graph are the group of native waters from figure 10. Figure 11 shows that the points representing the contaminated waters scatter to the right and range upward. In terms of character change, departure to the right indicates an increase in the proportion of sulfate or chloride and a similar increase in the proportion of sodium. The shift upward and increased concentration denotes an increase in calcium and magnesium and a proportionate loss of sodium. Inferentially, the increase in alkaline earths at the expense of the sodium might be interpreted to indicate that a high-calcium or high-magnesium contaminant is present in Ballona Gap. However, neither here nor in the Long Beach-Santa Ana area has such a contaminant been found. Therefore, the increase in alkaline earths is presumed to be due to

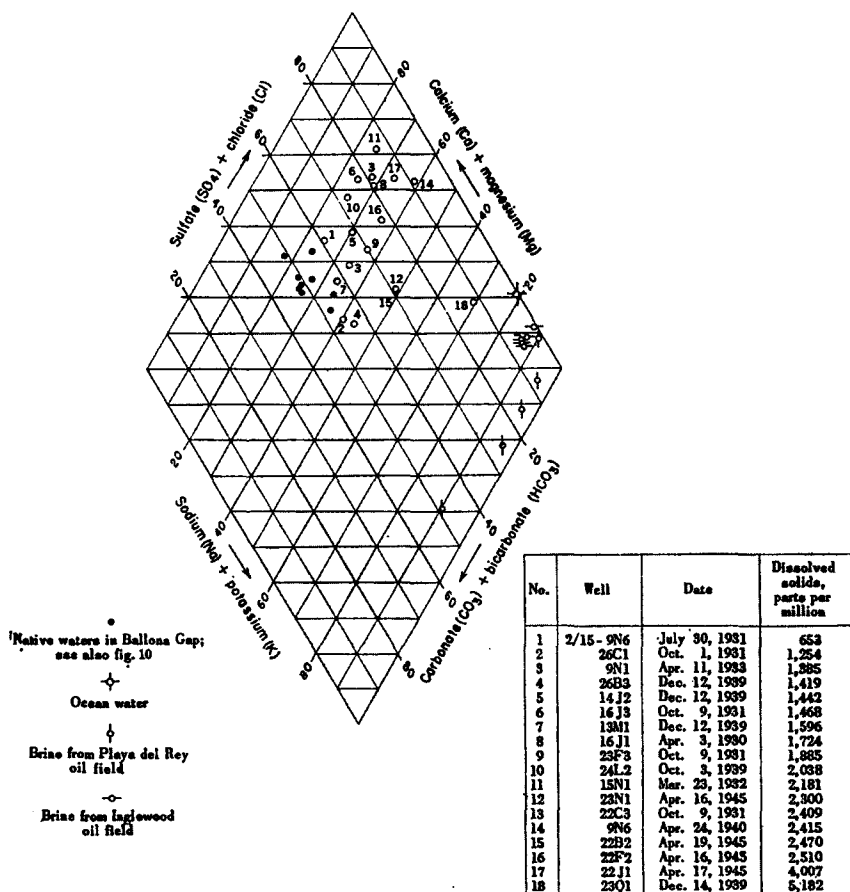

FIGURE 11.—Chemical character of native and contaminated waters in the coastal part of Ballona Gap.

base exchange, in which the sodium in the incoming contaminant is replaced nonuniformly by calcium or magnesium, or both. As will be noted on figure 11, the occurrence of base exchange disguises completely any possible gradation in quality toward that of known contaminants. As shown on the illustration it is obvious that, as salinity of the water increases, the path of the plotted points does not head toward the plots for either ocean water or a typical oil-field brine. If the degree to which base exchange has occurred could be determined and a correction made in the position of the plotted points, then a trend toward one or the other of the possible contaminants might actually occur.

Although, as shown by figure 11, no consistent trend in chemical character occurs with increasing concentration, it will be noted from data presented below that from the coast to about 1.5 miles inland,

or about to Lincoln Boulevard, chloride increase is attended by an increase in sulfate in about the proportion to be expected if ocean water were the contaminant. The progress of contamination from Lincoln Boulevard inland to near Sepulveda Boulevard indicates that the sulfate content of the contaminated waters has increased above that which could possibly result from the addition of sulfate carried into the aquifers by ocean water alone. Hence, inferentially, the encroachment of ocean water into Ballona Gap extends about to Lincoln Boulevard, or nearly as far as the 500 ppm chloride contour shown on plate 16.

To show the proportionate amount of sulfate increase in the coastal strip, analyses of contaminated water from three wells have been selected (2/15-9N6, 16J1, and 26C1, all within 1.75 miles of the coast) and are compared to hypothetical mixtures of native waters with ocean water. Table 18 shows these contaminated waters and the corresponding hypothetical mixtures, based on an equality of chloride concentration. As the table shows, only 9N6 contained an excess sulfate content (8 percent) but, because of possible analytical errors in the determination of that constituent, this small excess is not considered to be sufficient to rule out ocean water as the contaminant. On the other hand, analysis 26C1 showed a deficiency of 42 percent in sulfate content. In this case, however, a loss in sulfate is

TABLE 18.—Contaminated water from wells 2/15-9N6, 16J1, and 26C1, in comparison with hypothetical mixtures of the presumed native water with ocean water

|                                                                                                                      | Constituents    |                        |                |                                         |                               |                  |
|----------------------------------------------------------------------------------------------------------------------|-----------------|------------------------|----------------|-----------------------------------------|-------------------------------|------------------|
|                                                                                                                      | Calcium<br>(Ca) | Magne-<br>sium<br>(Mg) | Sodium<br>(Na) | Bicarbon-<br>ate<br>(HCO <sub>3</sub> ) | Sulfate<br>(SO <sub>4</sub> ) | Chloride<br>(Cl) |
| Parts per million:                                                                                                   |                 |                        |                |                                         |                               |                  |
| Presumed native water of well 2/15-9N6, April 11, 1933.....                                                          | 76              | 26                     | 78             | 274                                     | 151                           | 60               |
| Well 2/15-9N6, contaminated water of Apr. 24, 1940.....                                                              | 380             | 60                     | 465            | 250                                     | 323                           | 1,180            |
| Native water mixed with ocean water.....                                                                             | 95              | 100                    | 711            | 266                                     | 299                           | 1,180            |
| Well 2/15-16J1, contaminated water of Apr. 3, 1930.....                                                              | 270             | 105                    | 210            | 373                                     | 231                           | 720              |
| Native water mixed with ocean water.....                                                                             | 87              | 70                     | 451            | 269                                     | 238                           | 720              |
| Well 2/15-26C1, contaminated water of Oct. 1, 1931.....                                                              | 131             | 90                     | 225            | 662                                     | 112                           | 373              |
| Native water mixed with ocean water.....                                                                             | 81              | 47                     | 255            | 272                                     | 192                           | 373              |
| Equivalents per million:                                                                                             |                 |                        |                |                                         |                               |                  |
| Well 2/15-9N6, Apr. 24, 1940.....                                                                                    | 18.97           | 4.93                   | 20.21          | 4.10                                    | 6.72                          | 33.29            |
| Native waters mixed with ocean water.....                                                                            | 4.75            | 8.20                   | 30.92          | 4.36                                    | 6.22                          | 35.29            |
| Well 2/15-16J1, Apr. 3, 1930.....                                                                                    | 13.48           | 8.64                   | 9.11           | 6.11                                    | 4.81                          | 20.31            |
| Native water mixed with ocean water.....                                                                             | 4.36            | 5.72                   | 19.59          | 4.41                                    | 4.95                          | 20.31            |
| Well 2/15-26C1, Oct. 1, 1931.....                                                                                    | 6.54            | 7.40                   | 9.76           | 10.85                                   | 2.83                          | 10.52            |
| Native water mixed with ocean water.....                                                                             | 4.06            | 3.83                   | 11.09          | 4.46                                    | 4.00                          | 10.52            |
| Excess (+) or deficiency (-) of the contaminated waters with respect to native and ocean water mixtures, as follows: |                 |                        |                |                                         |                               |                  |
| Water of 2/15-9N6.....                                                                                               | +14.22          | -3.27                  | -10.71         | - .26                                   | + .50                         | -----            |
| Water of 2/15-16J1.....                                                                                              | +9.12           | +2.92                  | -10.48         | +1.70                                   | - .14                         | -----            |
| Water of 2/15-26C1.....                                                                                              | -2.48           | +3.67                  | -1.33          | +6.39                                   | -1.67                         | -----            |

not diagnostic, because the process of sulfate reduction is common in both native and contaminated waters—it certainly could have occurred here. Referring again to the table, all the contaminated waters are lower in sodium and higher in the sum of calcium and magnesium than the hypothetical mixtures. This discrepancy is due to base exchange in the direction of calcium enrichment and is to be expected. Hence, its occurrence will not, in itself, invalidate the postulation of ocean-water contamination of those well waters whose analyses are examined here.

In contrast, table 19 presents the sulfate content of water from a number of wells inland from the 500 ppm chloride contour, but coastward from Sepulveda Boulevard. The sulfate content of these waters is compared to that which would result from mixtures of native water with ocean water, based on an equality of chloride concentration. As may be seen from the table, all the analyses cited show more sulfate in the contaminated water than could possibly have resulted from an ocean water-native water blend. The excess of sulfate, expressed as the percent of excess over that contained in the hypothetical blend, ranges from 31 to 440 ppm for waters in the confined body. Well 2/15-23Q1, tapping the unconfined body, yielded water in which the percent excess of sulfate with respect to the native confined water is 1,240 ppm. Thus, considering the change in sulfate concentration that has occurred, the shallow water could be causing part of the contamination. Hence, for the coastal part of Ballona Gap, the concentration of sulfate suggests that ocean-water contamination doubtless has occurred inland about to and possibly beyond Lincoln Boulevard. From Lincoln Boulevard to Sepulveda Boulevard, the shallow water in the unconfined body may be the principal contaminant. However, it is likely that the boundary between the ocean-water and high-sulfate-water contamination is very irregular and indefinite.

In an attempt to define the position of this boundary, and to identify the contaminant inland from Lincoln Boulevard, three other chemical characteristics of potential contaminants were considered. These characteristics are (1) bicarbonate content, (2) calcium-magnesium ratio, and (3) borate content. The study of these characteristics failed to provide a better definition of the boundary.

1. The bicarbonate content in ocean water is about 140 ppm; in the shallow unconfined waters of Ballona Gap it commonly is about 500 to 700 ppm but in one locality it is as great as 1,670 ppm; in oil-field brines from the Inglewood field—according to six available analyses—it ranges from 297 to about 2,000 ppm and averages 1,350 ppm. In native waters in Ballona Gap it probably ranged about from 275 to 300 ppm. Therefore, a Ballona Gap native water contaminated by ocean water alone would decrease in bicarbonate, but if the contaminant were either shallow unconfined water, or an oil-field brine, the

TABLE 19.—Sulfate content of water from selected wells in the coastal part of Ballona Gap in comparison to that resulting from a hypothetical mixture of native water<sup>1</sup> and ocean water

| Well           | Parts per million |                  |                        | Excess (percent) |
|----------------|-------------------|------------------|------------------------|------------------|
|                | Chloride          | Sulfate (actual) | Sulfate (hypothetical) |                  |
| 2/15-13J3..... | 456               | 492              | 208                    | 137              |
| 13M1.....      | 375               | 295              | 192                    | 54               |
| 14Q1.....      | 259               | 231              | 177                    | 31               |
| 15N1.....      | 604               | 492              | 223                    | 121              |
| 22B2.....      | 222               | 931              | 173                    | 438              |
| 2/15-22C1..... | 266               | 835              | 169                    | 394              |
| 22C3.....      | 337               | 674              | 188                    | 259              |
| 23A2.....      | 187               | 532              | 168                    | 217              |
| 23A3.....      | 214               | 449              | 172                    | 161              |
| 23C1.....      | 371               | 483              | 193                    | 150              |
| 2/15-23F3..... | 206               | 593              | 170                    | 249              |
| 23G1.....      | 240               | 607              | 175                    | 247              |
| 23G2.....      | 231               | 633              | 174                    | 264              |
| 23H1.....      | 300               | 730              | 183                    | 299              |
| 23J2.....      | 174               | 476              | 166                    | 187              |
| 2/15-23M3..... | 250               | 583              | 176                    | 231              |
| 23Q1.....      | 941               | 2,234            | 167                    | 1,240            |
| 24L2.....      | 208               | 923              | 171                    | 440              |

<sup>1</sup> Native water selected is that from well 2/15-9N3, analysis of Apr. 11, 1933.

bicarbonate content of the contaminated water would increase slightly and irregularly. A study of the analyses of contaminated waters throughout the coastal part of Ballona Gap indicates that in such waters a bicarbonate content of 400 to 500 ppm is common and that, with very few exceptions, notably at the Marine plant of the city of Santa Monica, the increase in chloride is attended by an increase in bicarbonate. Well 2/15-9N6, at the Marine plant, yielded water that decreased in bicarbonate from 308 ppm in 1931 to 226 ppm in 1940. Over the same period, the chloride content increased from 81 to 930 ppm. However, here the bicarbonate loss is considerably more than would result from ocean-water contamination alone. In general, the conclusion was reached that, for this coastal area of Ballona Gap, bicarbonate is useless as a criterion for determination of the sources of contaminants.

2. The calcium-magnesium ratio for ocean water, computed from equivalents per million, is 0.19; for oil-field brines from the Inglewood field, it ranges from 0.28 to 1.04 and averages 0.56, according to six available analyses; for shallow, unconfined waters, it appears to be less than 1 (well 2/15-23Q1, 0.57; well 23Q2, 0.73). For presumed native waters in Ballona Gap, the ratio ranges from 1.2 to 2; hence, it would be expected that native waters rendered inferior by blending with any of the known contaminants, would show a decrease in calcium-magnesium ratio concurrent with salinity increase; of course, for only moderate contamination the decrease would be slight. According to computations (not presented here), such a decrease in calcium-magnesium ratio does not occur. Actually, with increase in salinity of randomly selected native waters, a considerable scatter (from 0.9 to 2.5) occurs in the value of the ratio; therefore, such a ratio could be of little value in discriminating the source of a contaminant.

In contrast, waters in Dominguez Gap that were contaminated by ocean water have a much lower calcium-magnesium ratio than waters contaminated by oil-field brines (at least, for chloride concentrations less than 1,000 ppm). There, in water contaminated from the ocean, the ratio averages about 0.6, whereas in

waters primarily contaminated by oil-field brine, the ratio averages about 2.3 (Piper, Garrett, and others, 1953, p. 190). That is, a calcium-magnesium ratio much greater than 0.6 would seem to indicate a contaminant other than ocean water. In regard to those waters in Dominguez Gap, the base-exchange reactions, which usually occur with blending of native waters and saline waters and which cause much irregularity in the proportion of bases, was operative to only a small extent. On the other hand, in Ballona Gap, the great irregularity in calcium-magnesium ratios in contaminated waters doubtless results from base-exchange reactions which prevent the use of that ratio as a diagnostic characteristic.

3. The borate content in ocean water is about 25 ppm. In presumed native waters of Ballona Gap, the borate content commonly ranges from 0.3 to 0.8 ppm, although some of these native waters—particularly those which may represent a blend with waters from the flank of the Santa Monica Mountains—contain as much as 1.4 ppm. Therefore, if a contaminated water with 500 ppm of chloride contains more than about 1.5 to 2 ppm of borate, it is inferred that some saline water other than ocean water has been the cause of such contamination. Little is known concerning the borate content of potential contaminants in Ballona Gap; however, a sample of water from Ballona Creek, collected in 1931, contained 350 ppm of chloride and more than 5 ppm of borate. Although not in Ballona Gap, and cited for example only, a sample of water collected in 1932 from the Los Angeles River just downstream from the sumps of Oil Operators, Inc., contained 14,289 ppm of chloride and 169 ppm of borate. Fragmentary data not presented here suggest that oil-field brines in the Los Angeles basin contain several times as much borate as ocean water (Piper, Garrett, and others, 1953, p. 67 and table 8).

Information on the borate content of contaminated waters in the coastal part of Ballona Gap shows that at least 13 wells have yielded water containing more than about 1.5 ppm of borate (for waters in which the chloride content is not appreciably more than 500 ppm). Of these 13 wells, 8 are in sec. 23, T. 2 S., R. 15 W.; all of the wells are in that part of the coastal reach of Ballona Gap about from Lincoln Boulevard to Centinela Boulevard. For 12 of these wells, the borate content ranges from 1.6 to 3.4 ppm. The additional well, 2/15-23N1, yielded water in 1931 containing 7.6 ppm. Nearly all of these wells are farther inland than the presumed inland extent of ocean-water contamination, as determined on the basis of sulfate content. However, throughout the area in which the 13 foregoing wells are located, other wells, equally saline, contain only slightly larger amounts of borate than is presumed to have occurred in the native waters; many of these wells yield high-sulfate waters. Therefore, it is concluded that the borate content of contaminated waters inland from Lincoln Boulevard is of virtually no value in attempting to delimit the inland extent of ocean-water contamination, because no definite borate-chloride ratio seems to exist.

With respect to possible contamination from Ballona Creek, the available analyses of side inflows and creek water are listed in table 20.

The points where the samples were taken are shown by corresponding numbers on plate 17. The table shows that waters discharged into the creek are of sufficiently great sulfate and chloride content to cause contamination of ground waters within the coastal reach inland from tidewater; that is, providing that the materials beneath and adjacent to the creek are sufficiently permeable to permit appreciable seepage from the creek. Regarding such seepage, the California Division of Water Resources (1933, p. 26) notes that, "Discharge during summer usually penetrates into creek bottom before reaching tidewater." At the time of this observation, August 1931, the flow in the creek was estimated at 3 cfs.

TABLE 20.—Chloride, bicarbonate, and sulfate content of water samples from Ballona Creek and its tributaries or points of inflow, 1931-40

[Analyses principally by Los Angeles County Flood Control District]

| Number on plate 17 | Sampling point                                                                                                            | Date sampled  | Constituents, parts per million |                                 |                            |
|--------------------|---------------------------------------------------------------------------------------------------------------------------|---------------|---------------------------------|---------------------------------|----------------------------|
|                    |                                                                                                                           |               | Chloride (Cl)                   | Bicarbonate (HCO <sub>3</sub> ) | Sulfate (SO <sub>4</sub> ) |
| 1                  | La Cienega storm drain; west half, near West Adams Blvd., 200 feet north of Washington Blvd.                              | Apr. 20, 1931 | 86                              | 353                             | 45                         |
|                    |                                                                                                                           | Mar. 1, 1932  | 304                             | 418                             | -----                      |
| 2                  | La Cienega storm drain, east half.....                                                                                    | Apr. 20, 1931 | 160                             | 353                             | 100                        |
|                    |                                                                                                                           | Mar. 1, 1932  | 241                             | 500                             | -----                      |
| 3                  | Sacatela storm drain, 50 feet upstream from outlet of La Cienega storm drains                                             | Mar. 1, 1932  | 227                             | 369                             | -----                      |
|                    |                                                                                                                           | Mar. 1, 1932  | 227                             | 369                             | -----                      |
| 4                  | Spring at west half of La Cienega storm drain....                                                                         | Mar. 1, 1932  | 524                             | 622                             | -----                      |
| 5                  | Spring, 700 feet upstream from Higuera St., discharging to Ballona Creek from northwest bank.                             | Mar. 1, 1932  | 4, 354                          | 806                             | -----                      |
| 6                  | Storm drain, Moynier Lane, 900 feet south of West Adams Blvd.                                                             | Mar. 25, 1932 | 4, 083                          | 778                             | 1, 880                     |
|                    |                                                                                                                           | Mar. 1, 1932  | 468                             | 422                             | -----                      |
| 7                  | do.....                                                                                                                   | Mar. 1, 1932  | 262                             | 320                             | -----                      |
| 8                  | Creek flowing from north flank of Baldwin Hills and entering Ballona Creek about at Jefferson Blvd.                       | Dec. 21, 1939 | 2, 633                          | 363                             | -----                      |
|                    |                                                                                                                           | Dec. 21, 1939 | 2, 633                          | 363                             | -----                      |
| 9                  | Spring, issuing from cave at north flank of Baldwin Hills, 0.37 mile south of Jefferson Blvd., in Lenawee Ave., extended. | Apr. 29, 1932 | 311                             | 581                             | -----                      |
| 10                 | Ballona Creek, at Duquesne St. Analyses by California Division of Water Resources.                                        | Aug. 19, 1931 | 350                             | 360                             | 201                        |
|                    |                                                                                                                           | Aug. 11, 1937 | 240                             | 361                             | 218                        |
|                    |                                                                                                                           | Oct. 27, 1937 | 532                             | 394                             | 231                        |
|                    |                                                                                                                           | Feb. 21, 1938 | 265                             | 508                             | 225                        |
| 11                 | Ballona Creek, at Sawtelle Blvd.....                                                                                      | Dec. 27, 1939 | 368                             | -----                           | -----                      |
|                    |                                                                                                                           | Apr. 25, 1940 | 489                             | -----                           | -----                      |
| 12                 | Ballona Creek, at Inglewood Blvd.....                                                                                     | Dec. 17, 1935 | 68                              | -----                           | -----                      |
|                    |                                                                                                                           | Jan. 30, 1936 | 185                             | -----                           | -----                      |
|                    |                                                                                                                           | Apr. 15, 1936 | 460                             | -----                           | -----                      |
|                    |                                                                                                                           | May 11, 1936  | 446                             | -----                           | -----                      |
|                    |                                                                                                                           | Oct. 14, 1936 | 383                             | -----                           | -----                      |
|                    |                                                                                                                           | Jan. 19, 1937 | 388                             | -----                           | -----                      |
|                    |                                                                                                                           | Mar. 8, 1937  | 450                             | -----                           | -----                      |
|                    |                                                                                                                           | Nov. 27, 1939 | 441                             | -----                           | -----                      |
|                    |                                                                                                                           | Aug. 24, 1936 | 629                             | -----                           | -----                      |
|                    |                                                                                                                           | Oct. 14, 1936 | 321                             | -----                           | -----                      |
| 13                 | Ballona Creek, at Centinela Blvd.....                                                                                     | Jan. 19, 1937 | 306                             | -----                           | -----                      |
|                    |                                                                                                                           | May 10, 1937  | 287                             | -----                           | -----                      |
|                    |                                                                                                                           | Nov. 27, 1939 | 356                             | -----                           | -----                      |
|                    |                                                                                                                           | Dec. 9, 1939  | 306                             | -----                           | -----                      |
|                    |                                                                                                                           | Aug. 24, 1936 | 7, 560                          | -----                           | -----                      |
|                    |                                                                                                                           | Jan. 19, 1937 | 12, 600                         | -----                           | -----                      |
| 14                 | Ballona Creek, at Lincoln Blvd. Sampling point within tidal reach in creek.                                               | Dec. 14, 1939 | 17, 600                         | -----                           | -----                      |
|                    |                                                                                                                           | Jan. 30, 1936 | 186                             | 160                             | 80                         |
|                    |                                                                                                                           | Jan. 30, 1936 | 186                             | 160                             | 80                         |
|                    |                                                                                                                           | Feb. 11, 1936 | 15                              | 62                              | 17                         |
| do.....            | Ballona Creek. Sampling point not known. Analyses by Dr. Carl Wilson.                                                     | Feb. 11, 1936 | 15                              | 62                              | 17                         |



As discussed on page 187, the channel of Ballona Creek is paved with an impervious lining inland from La Salle Avenue; however, coastward from this avenue the bottom of the channel is unlined. The analyses (table 20) of creek water suggest that, if seepage has occurred here, the waters so introduced into the ground-water body may have caused a substantial part of the contamination. From La Salle Avenue inland, the ground-water bodies are protected from saline waters flowing within the creek channel. La Salle Avenue is 0.7 mile inland from the fault separating the Charnock and the crestral subbasins; hence, both basins are subject to possible contamination from the creek channel at the present time.

In regard to the sources of contamination in the coastal part of Ballona Gap, it may be concluded that inland at least as far as Lincoln Boulevard and including the abandoned Marine plant of the city of Santa Monica, ocean water has caused most if not all of the contamination. The presence of a landward hydraulic gradient from the early twenties to the late thirties coincides with this conclusion. The conclusion regarding an oceanic source of contamination is in general agreement with that of the Los Angeles County Flood Control District, which was the result of extensive work in Ballona Gap by that agency (Koch, 1940, p. 16).

The Los Angeles County Flood Control District also prepared the first detailed map showing contamination conditions in Ballona Gap. This map (Koch, 1940, pl. 2) shows lines of equal salinity and designates a suggested boundary between sea-water intrusion and oil-field brine pollution.

Inland about from Lincoln Boulevard to Sepulveda Boulevard, water from the shallow, unconfined body tentatively is presumed to be the chief cause of contamination, although near Lincoln Boulevard the contaminant may have been a blend of ocean water and unconfined water. Although confirmatory information is not available, it is likely that Ballona Creek has been an important factor in contaminating the shallow water body, at least as far inland as La Salle Avenue. Nowhere in this coastal part of Ballona Gap has it been possible to identify any contamination from oil-field brines. In part, this may stem from the difficulty of applying any of the criteria that ordinarily may be used in recognition of a blend of oil-field brine with native water.

#### CONTAMINATION ON THE WEST FLANK OF BALDWIN HILLS

An area of contamination developed on the west flank of the Baldwin Hills in the thirties; by 1946, about 200 acres east of the intersection of Overland Avenue and Jefferson Boulevard was underlain by water containing more than 500 ppm of chloride (pl. 16). Evidence suggesting that the contamination originates in the Baldwin

Hills is afforded by a sample of water (collected in 1939 from well 2/14-7K1), which contained 18,810 ppm of chloride. Referring to table 31, the chloride content of brines from the Inglewood oil field, based on six analyses, ranges from 17,500 to 20,000 ppm. The depth of well 2/14-7K1 is not known, but it is high on the west flank of the Baldwin Hills and presumably taps the San Pedro formation.

The location of well 7K1 is such that contamination by ocean water is physically impossible, because the base of these water-bearing deposits is more than 100 feet above sea level (pl. 2). Hence the well doubtless is contaminated by oil-field brines. It is to be expected that such highly contaminated waters would percolate through the water-bearing deposits and ultimately would contaminate wells in Ballona Gap. Evidence of this fact is provided from two analyses of water from well 2/15-7P2 (table 30). In June 1945 the well yielded water containing 600 ppm of chloride; in February 1946 it yielded water containing 1,100 ppm. During that period the sulfate content increased from 152 to 156 ppm; the comparatively small increase in sulfate is consistent with brine contamination considering the small amount of sulfate present in the brines of the Inglewood field. These two analyses are plotted on figure 12. The analyses are so plotted on this graph that the vertical height of a given constituent represents the amount of that constituent in equivalents per million. The oil-field brine contamination has reached at least as far south as wells 2/14-18F1 and 18F2; to the west it presumably extends into sec. 12, but chemical evidence showing its exact extent is lacking. As shown by plate 2, the permeable sand and gravel of the San Pedro formation crop out extensively to the north, east, and south of well 2/14-7K1, and any brines discharged at the land surface can readily move down the westerly dipping beds to the Overland Avenue fault.

#### CONTAMINATION ON THE NORTH FLANK OF BALDWIN HILLS

About 300 acres, located chiefly in sec. 5, T. 2 S., R. 14W., was underlain by contaminated waters in 1930-32. The contamination extended northward beyond well 2/14-5F2 and southward into the Baldwin Hills beyond well 8D1. Inferentially, this area became contaminated some years earlier than the coastal area. By 1931 several wells in 2/14-5P yielded water containing from 1,000 to 5,400 ppm of chloride. Because this contamination apparently is due to blending with oil-field brines, as will be explained, the contamination could have started at any time after 1924, which was the year of initial development in the Inglewood oil field. Analyses from three highly contaminated wells in this area are available: analyses 2/14-5N1, March 23, 1932; 2/14-5P1, October 22, 1931; and 2/14-5P3, October 2, 1931. Their chemical character is shown on figure 12. Of the

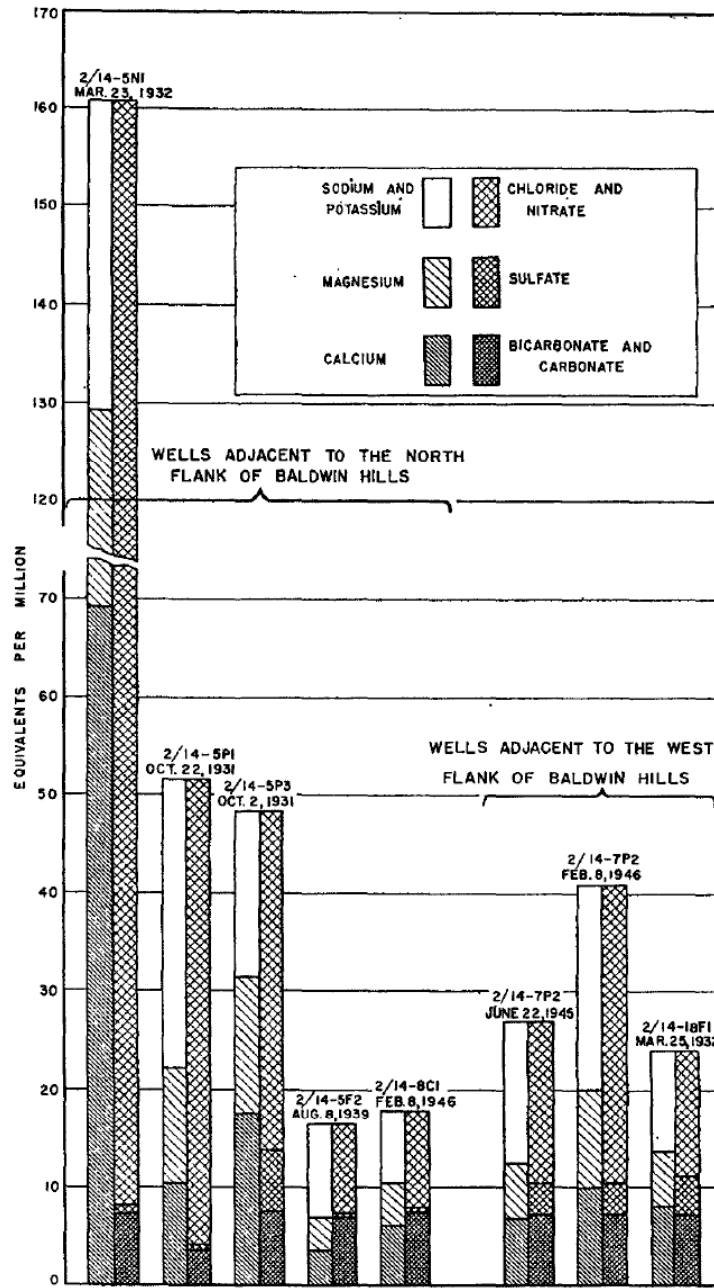

FIGURE 12.—Chemical character of contaminated waters from wells in Ballona Gap adjacent to the west and north flanks of Baldwin Hills.

analyses given, only 5P3 shows an appreciable amount of sulfate; however, in relation to the concentration of dissolved solids, that sulfate content is proportionally far less than in most of the contaminated waters toward the coast. Because the brines from the Inglewood field are low in sulfate—ranging from 13 to 56 ppm (table 31)—the low sulfate in the contaminated waters is a reasonably good indication of the source. Although well 5P1 contained 2.9 ppm and well 5P3 contained 3.5 ppm of borate, this constituent does not assist in isolating the source, because no analyses of borate in Inglewood brines are available.

Although it is possible that the contamination could have originated from Ballona Creek, such an origin is unlikely because of the following three important factors:

1. Because of the position of the contaminated area shown on plate 16 and because of the position of the more highly contaminated wells, a source to the south rather than to the north is the more logical.

2. Existing analyses of water samples from Ballona Creek upstream from the contaminated area fail to show the presence of waters sufficiently saline to cause the observed concentration in the contaminated wells.

3. Contamination from Ballona Creek would have resulted in definite impairment of the waters from one or more of the Sentney plant wells of the Southern California Water Co.

Hence, it is concluded that contamination here has been the result of discharge of oil-field brines from the Inglewood oil field.

Although the wells in 2/14-5P were strongly contaminated by 1931, recurrent chloride determinations from two wells, 2/14-5C1 and 5F2, plotted on figure 13, suggest that the concentration at these wells was not appreciably higher in the early forties than it was in 1931. Well 5C1, 0.2 mile east of the Sentney plant of the Southern California Water Co., taps essentially the same range as well 5D6 (Sentney plant,

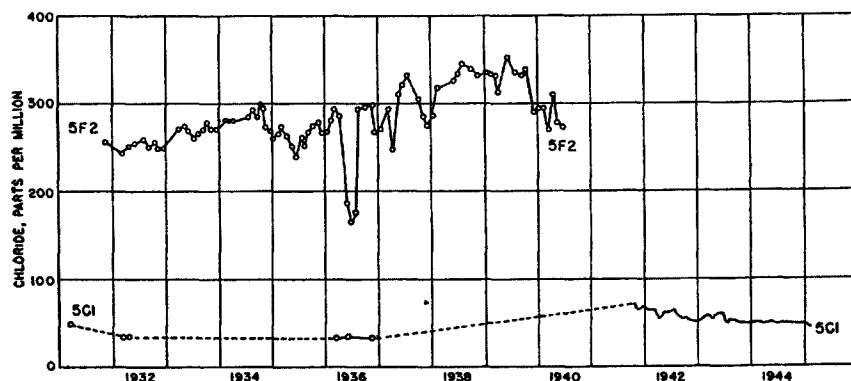

FIGURE 13.—Chloride content of waters from wells 2/14-5C1 and 2/14-5F2. Analyses chiefly by Los Angeles County Flood Control District.

well 6), and is about at the north edge of the contamination. Well 5F2, within the area of contamination, is about 0.2 mile south of 5C1. It is 260 feet deep and taps the upper part of the San Pedro formation. Well 5F2, although of irregular chloride content, showed an increase in salinity into 1939, then it showed a decrease. Well 5C1 may have reached a peak at about the same time as 5F2; chloride determinations on 5C1 from 1941 into 1945 show a decrease in chloride into 1944, then a leveling off at about 50 ppm. Well 5F2 yielded contaminated water containing very little sulfate and is assumed to be contaminated by oil-field brines.

To determine the current status of salinity in the area shown as contaminated in 1930-32 (pl. 16), an electrical-conductivity traverse was made on well 2/14-5P1 in July 1946. This unused well is located about 1,750 feet southeast of Ballona Creek and about 1,500 feet north of the flank of the Baldwin Hills. The measured depth was then 179 feet below land surface. The casing is perforated in gravel, 20 to 32 feet below land surface. As computed from values of specific conductance, the dissolved solids in the water within the casing, from water surface at 13 feet to 88 feet below land surface, ranged from 4,600 to 4,800 ppm. From 89 to 176 feet below land surface, the dissolved solids ranged from 7,400 to 8,000 ppm. In 1931 a sample from the well contained 2,856 ppm of dissolved solids; thus, at least at this one well, the salinity concentration has intensified appreciably during the 15-year period. Well 5N1, 1,000 feet northwest of 5P1, yielded water containing 8,528 ppm of dissolved solids in 1932; this well was not found in 1946, and its salinity at that time could not be determined.

#### WELLS AT THE SENTNEY PLANT OF THE SOUTHERN CALIFORNIA WATER CO.

In the NW¼ sec. 5, T. 2 S., R. 14 W., analyses of water from the Sentney plant wells of the Southern California Water Co. show that they yield waters with erratic fluctuations in chemical concentration; these analyses strongly suggest a blending of waters of different and distinct types. Although, as of 1946, all the active wells yielded presumably native water, distinct vertical differences in chloride concentration occur; water with the lowest chloride content is yielded from the lowest part of the water-bearing beds. Well 5C1, 0.2 mile east of the Sentney plant and perforated below 277 feet, yielded water containing 44 ppm of chloride in 1945. Well 5D6, perforated below 326 feet, yielded water containing 49 ppm of chloride in 1945. Well 5D4, for which the perforated interval is not known, yielded water containing as much as 219 ppm of chloride in 1936. The records of chloride content of water yielded from seven wells of the Sentney plant have been plotted on figure 14, together with the record of

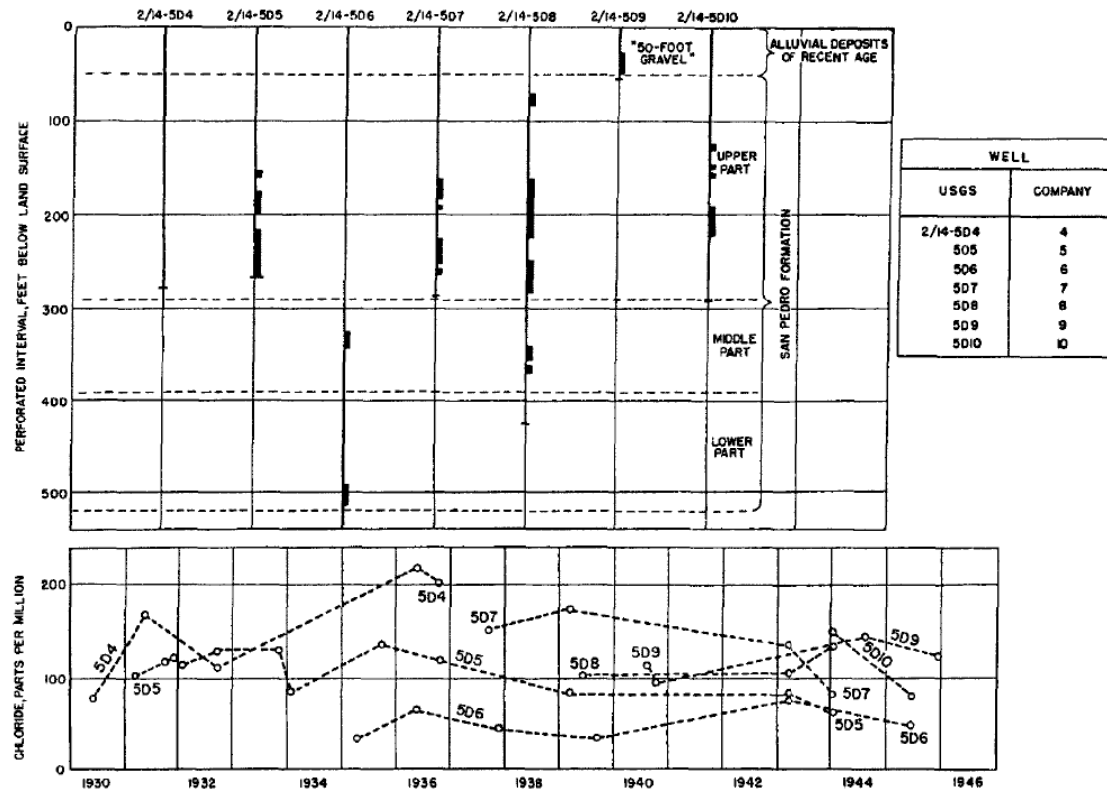

FIGURE 14.—Chloride content of waters and record of perforations for seven wells at the Sentney plant, Southern California Water Co.

perforations for these wells. Three conclusions may be drawn in part from the figure:

1. Well 5D6, which taps the middle and lower parts of the San Pedro formation, yielded water of the best quality, but as of 1943 the quality approached that of water yielded from the upper part of the formation.

2. Essentially no difference in chloride concentration exists between waters in the "50-foot gravel" of Recent age (well 5D9) and in the underlying upper part of the San Pedro formation. However, the former has yielded water definitely higher in sulfate than that from the San Pedro formation. Since 1944 analyses of water from well 5D9 tapping only the "50-foot gravel," have shown an increase in dissolved solids, which has been due chiefly to an increase in calcium and in sulfate.

3. For the respective zones tapped, only a comparatively small range in chloride content exists—as of 1944, from about 65 to 150 ppm. For the span of the records, no definite progressive contamination is indicated, with the possible exception of well 5D4, which has not been pumped since about 1936.

The heaviest production from the Sentney plant is from the upper part of the San Pedro formation—which here includes the main aquifers. Well 5F2, which is 0.4 mile southeast and was definitely contaminated in the thirties, also once yielded water from the upper part of the San Pedro formation. Because a steep cone of pressure relief has been maintained at the Sentney plant for many years (pls. 9-12 and 14) it might be expected that, at least by 1946 wells at the Sentney plant would have become contaminated from the south—that is, from the same source that caused well 5F2 to become saline. The fact that these wells have not yielded definitely contaminated water suggests a hydraulic discontinuity between the Sentney plant and the contaminated water body to the south. However, the hydrographs for wells 5D5 and 5F2 plotted on plate 14, suggest that no hydraulic separation exists. Accordingly, it is concluded that the bulk of the northward-migrating contaminant was withdrawn through wells 5F2, 5C1, and possibly other wells, in the thirties and early forties, and that a small marginal interception was withdrawn through wells 5D4 and 5D7 in the middle thirties (fig. 14).

Under native conditions, inferior waters occurred in sec. 32, T. 1 S., R. 14 W; in 1931 wells 32M1 and M3 yielded water containing 227 and 304 ppm of chloride, respectively. It is believed that these waters have migrated in part to the Sentney plant wells and have caused some of the observed fluctuations in chloride.

From existing analyses of water from the Sentney plant wells, it is inferred that as of 1946 the active wells were not contaminated, and that the recent fluctuations in chloride are not an indication of incipient contamination, but instead, they are a result of blending with inferior waters present to the north and east.

## RATE OF ADVANCE OF THE CONTAMINATION FRONT

In Ballona Gap the greatest advance of the contamination front in the last 16 years has been in the Charnock subbasin. From 1930-32 to 1945-46 the front has advanced about 1 mile, and in 1946 it was about 0.6 mile from the Charnock well field of the Southern California Water Co. This advance is estimated at an average rate of about 350 feet per year; the direction of advance is to the northwest and is in response to the hydraulic gradient developed by withdrawals from the Charnock field. If the front continues to advance at the same average rate, it will reach the Charnock field in 8 to 10 years. However, as the front moves closer to the field, it is expected that the rate of movement will be accelerated by the steeper gradient.

As of November 1945 (pl. 12), the hydraulic gradient to the well field from the northwest was about 30 feet per mile; from the southeast, about 15 feet per mile at the saline front. Thus, if the transmissibility of the deposits to the north and to the south is equal, about two-thirds of the supply is derived from the north and one-third from the south. The water now yielded from the Charnock well field contains about 50 ppm of chloride, about 700 ppm of dissolved solids, and 400 ppm of hardness (table 30). The saline waters just south of Ballona Creek in the Charnock subbasin contain as much as 500 ppm of chloride, 2,000 ppm of dissolved solids, and 800 ppm of hardness (table 29). If such saline waters eventually should reach the Charnock plant wells and should be withdrawn with the native waters in a proportion of 1:2, the resulting blend would contain about 200 ppm of chloride, 1,100 ppm of dissolved solids, and 500 ppm of hardness.

In the coastal area, contamination has advanced along about a 3-mile front, chiefly in secs. 14, 15, and 16, T. 2 S., R. 15 W. Part of the advance as shown on plate 16 is conjectural because of the scarcity of wells that could be used to locate the front more precisely. However, for the 16-year period the greatest advance appears to be along the west boundary of sec. 14 and in sec. 15, where it was from 0.7 to 0.9 mile. This represents an average yearly rate of about 260 feet, although for most of the front the rate is probably not more than half so great.

## CONTAMINATION FROM PLAYA DEL REY TO REDONDO BEACH

In the coastal reach from Playa del Rey southward to and somewhat beyond Redondo Beach—essentially the 11-mile reach from the Ballona escarpment to the Palos Verdes Hills—salt water has invaded the main water-bearing zone and now extends inland from half a mile to nearly 2 miles (pl. 16). Locally, this contaminated water contains as much as 5,000 ppm of dissolved solids.



Under the native conditions of coastward ground-water movement it is believed that waters of good or fair quality existed to the coast along essentially all of the reach from Playa del Rey to Redondo Beach. As of 1904, Mendenhall (1905b) canvassed 13 wells from Manhattan Beach to Redondo Beach that were less than 0.7 mile from the coast. Of these, all except three yielded water containing less than 600 ppm of dissolved solids. Only one well, in 3/15-36H (Mendenhall 273, Redondo), yielded water containing more than 1,000 ppm of dissolved solids. North of Manhattan Beach no wells had been drilled near the coast as of 1904—except near Playa del Rey in 2/15-34E (Mendenhall 80 and 81, Redondo), 0.4 mile inland from the coast. There, the main water-bearing zone yielded water containing 710 ppm of dissolved solids as of 1904.

So far as known, contamination within this coastal reach was first noted between 1912 and 1918—in well 4/14-6F1, at Hermosa Beach and 0.6 mile inland from the coast (p. 244). In the reach of greatest current inland advance at El Segundo, contamination was first reported in 1921 in wells of the Standard Oil Co.—in 3/15-13D and 14A (pl. 16). Well 3/15-14A2, about 0.6 mile inland from the coast, yielded water containing 90 ppm of chloride in 1920; this water was considered essentially native to the range tapped. Beginning in 1921, its quality deteriorated rapidly, however (fig. 20).

From 1920 to the early thirties, withdrawal from the Torrance-Inglewood subarea of the west basin increased substantially, largely because of the construction of a number of well fields supplying new industrial plants. As has been shown, water levels were lowered to and below sea level throughout most of the subarea. As a result of this lowering of water level, contamination of wells had occurred along most of the coastal reach from El Segundo to Redondo Beach by 1932.

The inland front of contaminated waters containing more than 100 ppm of chloride as of 1930-32 is shown on plate 16. At that time the greatest inland extent of the contaminated waters was about 1.3 miles at El Segundo; the least extent was not more than half a mile near Century Boulevard and at Hermosa Beach. Along the full 11-mile reach, the area then underlain by contaminated waters was about 5,000 acres, or nearly 8 square miles.

As of 1946, the front of waters containing more than 100 ppm of chloride, as shown on plate 16, ranged from half a mile inland near Century Boulevard to 1.7 miles at El Segundo. At Redondo Beach, the front then was 1.1 miles inland from the coast. From 1932 into 1946, the greatest advance of the saline front occurred between El Segundo and Manhattan Beach and was as much as 0.5 mile. However, the average advance of encroachment between Playa del Rey and Redondo Beach in the 14 years was about 0.3 mile, and the in-

crease in the area underlain by contaminated water was about 1,700 acres.

The withdrawal of water along the coastal reach is largely concentrated at five well fields or local centers of pumping. Analytical data relating to the active wells in these fields have been taken more or less continuously for many years. Thus, the rate of contamination, the chemical character of the contaminated waters, and the source or sources of contamination can be appraised best by analysis of conditions at these several well fields.

#### WELL FIELD AT PLAYA DEL REY

Just south of the Ballona escarpment in the vicinity of Playa del Rey, water is yielded only from the main water-bearing zone of the San Pedro formation, which here immediately underlies the dune-sand deposits and which, at least locally, is in hydraulic contact with them. At well 2/15-34A2 (Palisades del Rey Water Co. well 4) the main water-bearing zone is about 130 feet thick, and its top is about 30 feet above sea level. The log for this well is considered to be representative and is shown on plate 3C.

The Palisades del Rey Water Co. pumps water from two fields. The field in 2/15-34K is about 0.4 mile from the ocean; there two wells have been drilled, of which one (2/15-34K1) is now active. The other field, in 2/15-34A and 2/15-27R, is about 0.9 mile from the ocean and about 0.5 mile from the escarpment; there four wells have been drilled, and one (2/15-34A1) is now active. Of the two fields, that in 2/15-34K is the older; well 2/15-34K1 (Palisades del Rey Water Co. well 1) was drilled in 1924. The first well in field 2/15-34A (2/15-34A1) was drilled about in 1930.

Waters yielded from the two fields were chemically alike and ranged from sodium, calcium bicarbonate to sodium bicarbonate waters, although in the available analyses sodium always made up at least 44 percent of all the bases. In these waters under native conditions, the sulfate content was usually less than 40 ppm. Good series of chloride determinations are available for wells 2/15-34A1 and 34K1 and are plotted on figure 15. As shown in these chloride analyses, both wells became definitely contaminated by 1945, and well 2/15-34A1 was incipiently contaminated in the early thirties. Contamination now is much more serious at well 2/15-34K1, not only because the chloride content is nearly twice that at well 2/15-34A1, but also because the rate of contamination increase is many times greater, as indicated by the slope of the chloride graph.

A striking difference in character change of the two waters is shown by the graph of bicarbonate in water from the two wells (fig. 15). In 1929, both wells yielded water containing over 300 ppm of bicarbonate.

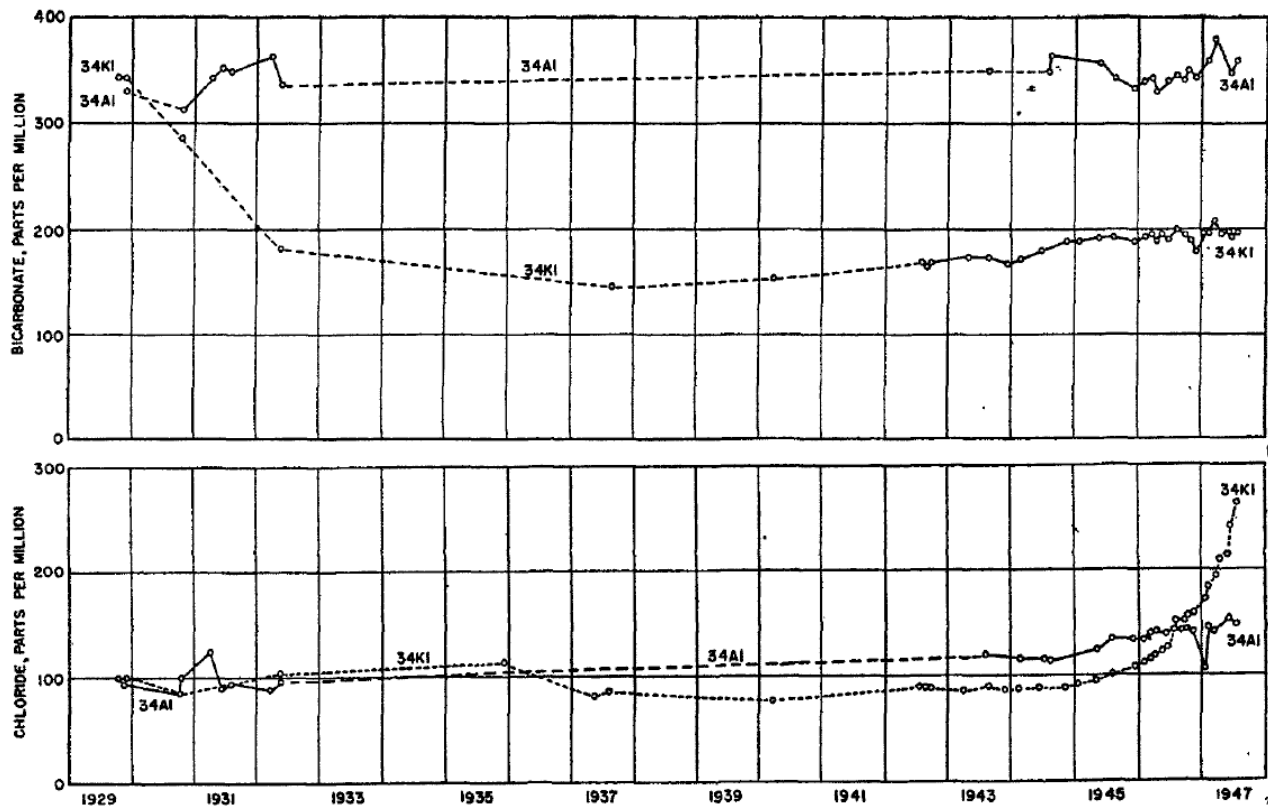

FIGURE 15.—Chloride and bicarbonate content of waters from wells 2/15-34A1 and 34K1 (Palsades del Rey Water Co. wells 3 and 1).

By 1932, the bicarbonate in well 34K1 had decreased to about 150 ppm; well 34A1 remained about the same through the period of record. Since about 1940, well 34K1 has shown an increase in bicarbonate to almost 200 ppm. The loss in bicarbonate in water from this well is accompanied by a loss of bases, chiefly in calcium and to a minor degree in sodium. It is interesting to note that the bulk of the bicarbonate loss in well 34K1 occurred during a period of very slight chloride increase. A possible explanation of the chemical behavior of this well is that the aquifer tapped by the well was being partly recharged by local rainfall on the sand-dune area. The San Pedro formation here is known to be in local hydraulic contact with the sand-dune deposits (p. 125, pl. 13).

Because the chloride increase in water from well 34K1 has become pronounced since 1945, with no corresponding gain in bicarbonate, it is tentatively concluded that the well is now within the area contaminated by ocean water. Furthermore, because the well is now within the area in which a regional inland gradient exists, it is expected that it soon will yield water unfit for use.

**WELL FIELD OF THE CITY OF EL SEGUNDO  
PERTINENT GEOLOGIC FEATURES**

At the well fields of the city of El Segundo in sec. 12, T. 3 S., R. 15 W., two distinct water-bearing zones in the deposits of Pleistocene age are tapped by wells. Recent deposits here consist solely of sand dunes and are non-water-bearing. The upper of the two Pleistocene aquifers is the "200-foot sand" of the unnamed deposits of upper Pleistocene age; here it ranges from 30 to 40 feet in thickness. The lower aquifer is the Silverado water-bearing zone and ranges from 70 to 140 feet in thickness. At the main well field of the city of El Segundo in 3/15-12L, only the upper 30 to 40 feet of the Silverado water-bearing zone is sufficiently coarse to permit perforation of well casings; the lower part, which is as much as 100 feet thick, consists of fine sand and some silt. In the NE¼ sec. 12, the logs of three municipal wells indicate a much more irregular lithology. Here also, the upper 30 to 40 feet of the Silverado water-bearing zone is permeable sand and gravel; however, in two of the three wells a basal gravel is present which is sufficiently permeable to yield water. The Silverado water-bearing zone is separated from the "200-foot sand" in the upper Pleistocene deposits by an impervious clay layer which is 15 to 40 feet thick. Both aquifers here dip gently southward (pl. 3C).

**SUMMARY OF NATIVE WATER QUALITY**

Inland from the coast, toward the axis of the syncline underlying the Torrance plain (pl. 2), it has been possible to distinguish between the quality of the water in the unnamed upper Pleistocene deposits

218 GEOLOGY, HYDROLOGY, TORRANCE-SANTA MONICA AREA

and that of the water in the Silverado water-bearing zone beneath, because chemical analyses are available for waters from certain wells tapping the upper zone only and from other wells tapping the Silverado zone only. In sec. 12, T. 3 S., R. 15 W., however, all wells tap both zones and thus yield blends of waters from the two aquifers. Necessarily, therefore, a description of native conditions here will be confined to these blended waters. An analysis of water from well 3/15-12L1, sampled March 4, 1930, is selected as representative of the native water throughout the local extent of the tapped water-bearing zones. From this analysis and from others, made before contamination had become more than incipient, it is inferred that these waters ranged about from 390 to 425 ppm in dissolved solids and contained less than 100 ppm—probably from 85 to 92 ppm—of chloride. The early (1929-30) analyses of water from wells of this field, particularly those from well 12L1, show an interesting fluctuation in sulfate content. For example, the analysis of 12L1 for February 13, 1931, shows that sulfate is absent. Other analyses of water from 12L1 for that period show that sulfate ranged from a trace to 35 ppm.

PROGRESS OF WATER-QUALITY DEPRECIATION

Table 21 lists all the wells drilled by the city of El Segundo and gives their status in 1946. Of the ten wells listed, seven were drilled at the main field near the city's water treatment plant at Grand Avenue and Maryland Street; only two wells, 12L5 and 12L7, were active in 1946. Of the other three wells, two are about 0.4 mile northeast of the main plant, and well 12B1, the latest one drilled, is about 0.2 mile north of the first-mentioned wells. All three are now active. Chloride analyses for wells 12L1, 12L3, and 12L6, plotted

TABLE 21.—History and chloride content of public-supply wells of the city of El Segundo

| Well              |                    | Date drilled | Chloride content                           |                              | Date abandoned | Reason for abandonment         |
|-------------------|--------------------|--------------|--------------------------------------------|------------------------------|----------------|--------------------------------|
| USGS <sup>1</sup> | City of El Segundo |              | Initial <sup>2</sup> analysis <sup>1</sup> | Latest <sup>3</sup> analysis |                |                                |
| 3/15-12L1         | 1                  | 1920         | 100                                        | 304                          | 1939           | Caved in.<br>Do.<br>Do.<br>(*) |
| 12L2              | 2                  | 1924         | 98                                         | 123                          | 1937           |                                |
| 12L3              | 3                  | 1930         | 104                                        | 211                          | 1940           |                                |
| 12L4              | 4                  | 1938         | 430                                        | 430                          | 1938           |                                |
| 12G2              | 5                  | 1939         | 113                                        | 138                          | (*)            |                                |
| 12G1              | 6                  | 1939         | 128                                        | 86                           | (*)            | Became saline.                 |
| 12L6              | 7                  | 1939         | 157                                        | 886                          | 1945           |                                |
| 12L5              | 8                  | 1942         | 116                                        | 245                          | (*)            |                                |
| 12L7              | 9                  | 1944         | 151                                        | 219                          | (*)            |                                |
| 12B1              | 10                 | 1945         | 82                                         | 86                           | (*)            |                                |

<sup>1</sup> United States Geological Survey.  
<sup>2</sup> Earliest analysis available.  
<sup>3</sup> Latest analysis available.  
<sup>4</sup> Abandoned at time of drilling; water too saline for use.  
<sup>5</sup> Active in December 1946.

on figure 16, show the development of contamination at the main field. Because of the fluctuation in chloride content for well 12L1 in 1930-31, it is thought that contamination was then incipient; by 1936 the increase in chloride content was positive. However, only in well 12L6 did salinity increase to a degree that made the water unusable. Wells 12L1 and L3 were abandoned because of mechanical difficulties; doubtless, the salinity of the water yielded by these wells would have increased appreciably above the amounts shown on the graph if pumping had been continued.

The two active wells at the main field as of 1946 (nos. 12L5 and 12L7) both yielded water containing more than 200 ppm of chloride at the end of that year. As shown by the graphs (fig. 16), the chloride content was about stable to mid-1946, and then it increased substantially. It is believed that if these wells are pumped almost continuously, within a relatively short time the chloride will increase at an accelerated rate—similar to the increase shown by the graph for well 12L6 in 1944-45 (fig. 16). Both of these active wells tap the same water-bearing zones that are tapped by wells 12L1, L3, and L6 (which were abandoned earlier). As shown later (p. 224), although both water-bearing zones are about equally contaminated, the upper of the two zones may be slightly more saline. Figure 16 also shows the chloride concentration of waters from wells 12G1 and 12G2. In contrast to chloride graphs for wells at the field in 3/15-12L, the graphs for both wells in 12G show a decrease in salinity (to a greater extent in well G2 than in well G1). Well 12G1 yields more water from a stratigraphically lower part of the Silverado water-bearing zone than any other city well. The monthly combined withdrawal for the two wells also has been plotted on figure 16. It will be noted that the chloride decrease has occurred over a period when withdrawals were nearly constant.

#### CHEMICAL FEATURES OF CONTAMINATION

As described earlier, at the main field of the city of El Segundo the trend of contamination is toward ever-increasing salinity and resultant abandonment of the wells; however, at the more recently developed field to the northeast in 3/15-12G, the trend since about 1941 is toward a decreasing salinity. In well 12G1 the water has almost returned to its native character. For all the wells of the city of El Segundo, the following description treats the manner in which contamination has occurred and suggests a possible source of this contamination. Although the analyses for any single well do not span the entire period of record, a series has been selected arbitrarily to show progressive increase in chloride content. These analyses have been plotted on a trilinear graph (fig. 17) which shows the salinity trend at the main field. Although some departure from a definite

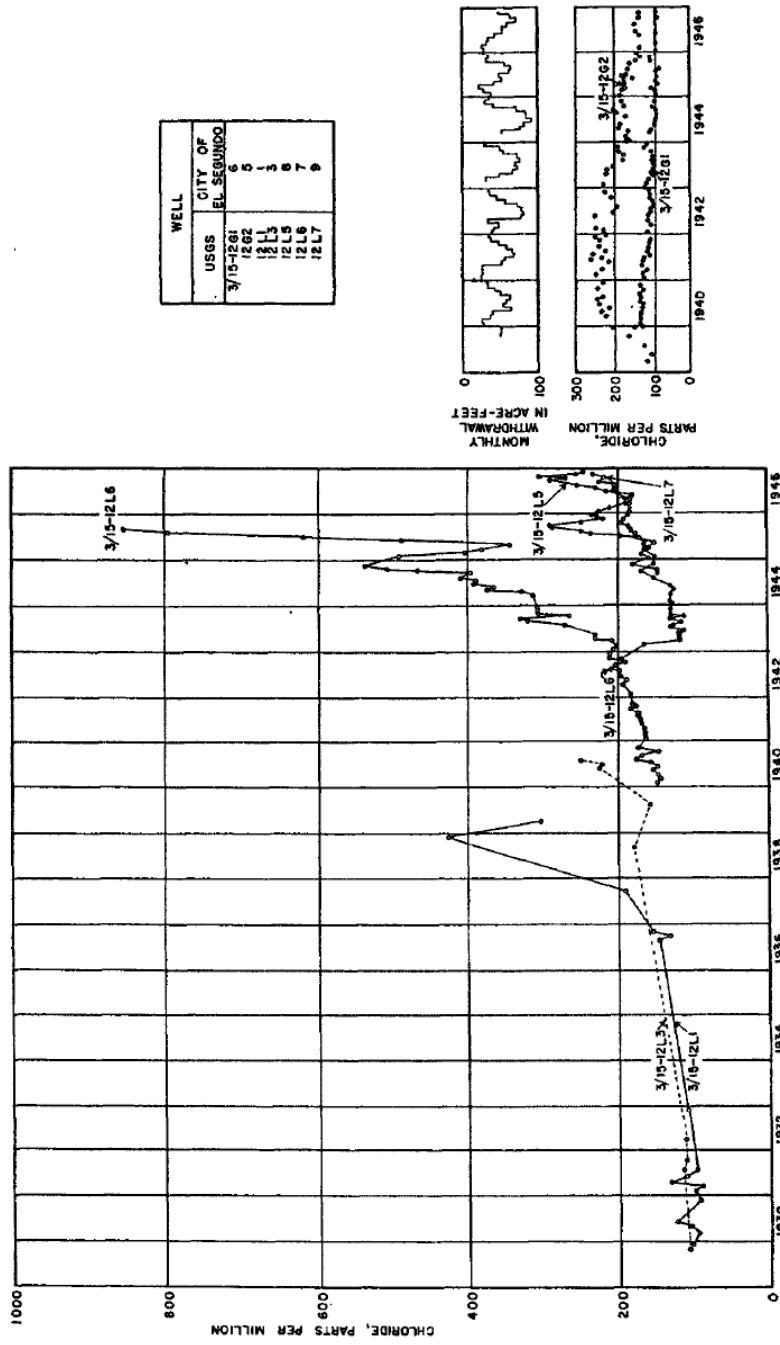
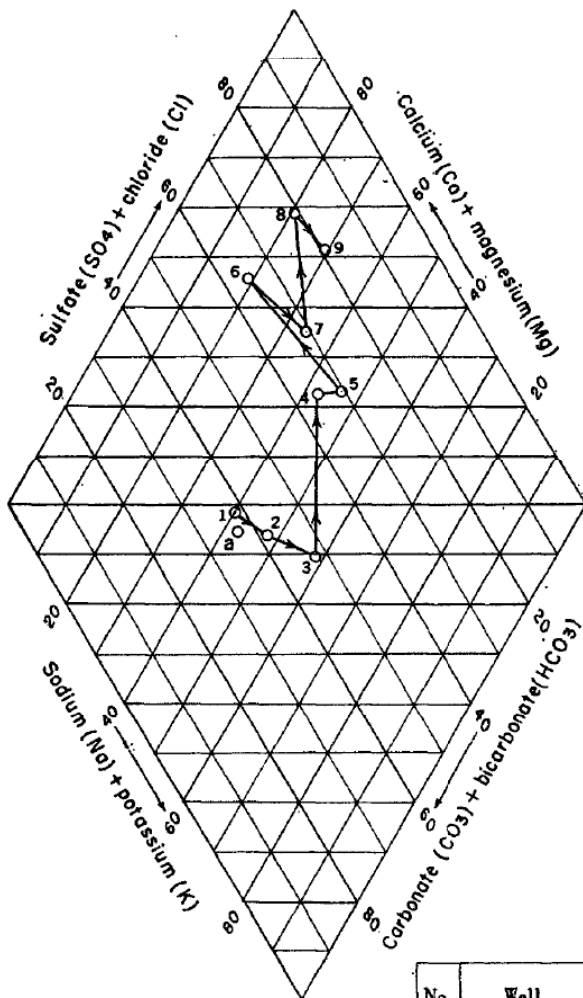

FIGURE 16.—Chloride content of waters from seven public-supply wells of the city of El Segundo.



| No. | Well        | Date           | Chloride, parts per million |
|-----|-------------|----------------|-----------------------------|
| a   | (3/15-12G1) | Feb. 25, 1945  | 92                          |
| 1   | 12L1        | Nov. 25, 1930  | 92                          |
| 2   | 12L2        | Sept. 11, 1930 | 104                         |
| 3   | 12L2        | Mar. 9, 1931   | 123                         |
| 4   | 12L3        | July 24, 1939  | 157                         |
| 5   | 12L6        | Jan. 4, 1940   | 181                         |
| 6   | 12L6        | Sept. 2, 1942  | 208                         |
| 7   | 12L6        | Apr. 24, 1943  | 220                         |
| 8   | 12L6        | Feb. 25, 1945  | 420                         |
| 9   | 12L6        | Oct. 24, 1944  | 520                         |

FIGURE 17.—Chemical character of native and progressively contaminated waters at the main well field of the city of El Segundo.



trend occurs, in general, as contamination progresses, the water is enriched chiefly in chloride and in calcium. Inasmuch as no known calcium-chloride contaminant is known to exist locally, it is assumed that the contaminant is a sodium-chloride saline in which base exchange has occurred during blending with the native water.

To determine the source of contamination at this field, use is made of the chloride-bicarbonate ratios of the progressively contaminated waters for which the analyses have been plotted on figure 17. Figure 18 shows these ratios plotted against the chloride content; hypothetical

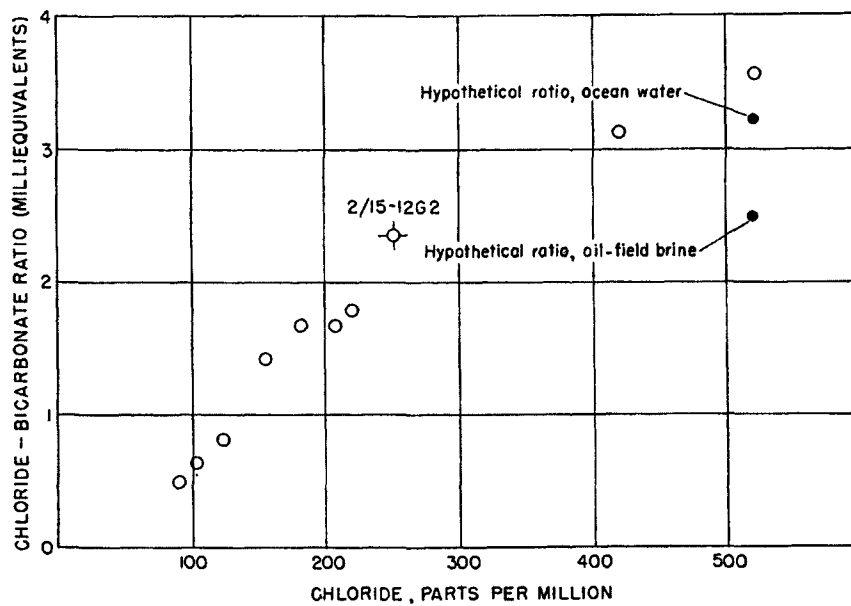

FIGURE 18.—Chloride-bicarbonate ratios of progressively contaminated waters at the main well field of the city of El Segundo.

ratios for a sea-water mixture and an oil-field brine mixture with a native water are plotted also. Sea water is strongly suggested as the source of contamination. That is, for the contaminated water containing 520 ppm of chloride, the  $\text{Cl-HCO}_3$  ratio is 3.58; for the ocean-water and brine mixtures with native water, computed to the same chloride concentration, the ratios are 3.21 and 2.49, respectively. The points representing the actual analyses fall on a reasonably well defined curve which approaches the point representing the ocean-water mixtures more closely than that representing the oil-field brine mixture.

The analysis used in computing the hypothetical mixture of brine and native waters was furnished by the Richfield Oil Corp. The water analyzed was from Richfield well El Segundo No. 2 (in 3/14-18G) and was yielded through perforations from 7,243 to 7,319 feet below

the land surface—presumably from rocks of upper Miocene age (pl. 7). The constituents cited below were determined from a sample collected and analyzed by the Richfield Oil Corp. for the Geological Survey; quantities are reported in parts per million (except pH which is reported in percent):

|                               | <i>Parts per million</i> |                              | <i>Parts per million</i> |
|-------------------------------|--------------------------|------------------------------|--------------------------|
| Silica.....                   | 81                       | Chloride.....                | 9,390                    |
| Iron and aluminum oxides..... | 3                        | Dissolved solids.....        | 24,561                   |
| Hydroxyl.....                 | 0                        | Suspended solids.....        | 207                      |
| Carbonate.....                | 0                        | Water soluble organic matter |                          |
| Bicarbonate.....              | 1,946                    | (approx.).....               | 5,300                    |
| Sulfate.....                  | 26                       | pH.....                      | 7.8                      |

<sup>1</sup> In percent.

Although the trend in chloride-bicarbonate ratios suggests ocean water as the contaminant, the other possible diagnostic constituent, sulfate, is not entirely confirmed by table 22. In the table, the actual sulfate content of the progressively contaminated waters is compared with the sulfate content that would be present if sea water alone had caused the chloride increase. In most of the contaminated waters sulfate is shown to be present in excess; this fact suggests a source of sulfate in addition to that brought in with sea water.

TABLE 22.—Comparison of actual and hypothetical sulfate content in progressively contaminated waters in the main well field of the city of El Segundo

| Well           | Date of sample | Chloride (ppm) | Sulfate (ppm) |                           | Excess (+) or deficiency (-) of sulfate (ppm) |
|----------------|----------------|----------------|---------------|---------------------------|-----------------------------------------------|
|                |                |                | Actual        | Hypothetical <sup>1</sup> |                                               |
| 3/15-12L1..... | Nov. 25, 1930  | 92             | 14            | .....                     | .....                                         |
| 12L2.....      | Sept. 11, 1930 | 104            | 19            | 14                        | +5                                            |
| 12L2.....      | Mar. 9, 1931   | 123            | 17            | 18                        | -1                                            |
| 12L3.....      | July 24, 1939  | 157            | 60            | 23                        | +37                                           |
| 12L6.....      | Jan. 4, 1940   | 181            | 90            | 26                        | +64                                           |
| 12L6.....      | Sept. 2, 1942  | 208            | 20            | 30                        | -10                                           |
| 12L6.....      | Apr. 24, 1943  | 220            | 76            | 32                        | +44                                           |
| 12L6.....      | Feb. 25, 1945  | 420            | 97            | 60                        | +37                                           |
| 12L6.....      | Oct. 24, 1944  | 520            | 119           | 74                        | +45                                           |

<sup>1</sup> Computed from a hypothetical mixture of sea water and a native water of 14 ppm sulfate, for which mixture the chloride content is identical to that of the actual contaminated water under comparison.

In regard to contamination at wells 12G1 and 12G2, the salinity increase has not yet become sufficiently intense that the source can be identified. It is inferred that the cause of contamination is the same at the two fields. If such is the case, the chemical character of the contaminated waters would be expected to be the same in both areas. As a check on this inference, the analysis of water from well 12G2 for February 7, 1942, has been selected for comparison. This analysis represents the most saline water of record taken from this well. The chloride-bicarbonate ratio for well 12G2 plotted on figure 18 falls close to the generalized curve. The value of 74 ppm for sulfate

is in excess of that brought in by sea water by about the same amount as in the wells in the main field (in 3/15-12L).

For the main field, the Geological Survey in 1945 conducted a series of pumping tests on well 12L6 in order to determine, if possible, which of the two water-bearing zones tapped would yield water of better quality. Figure 19 shows the electrical-conductivity values

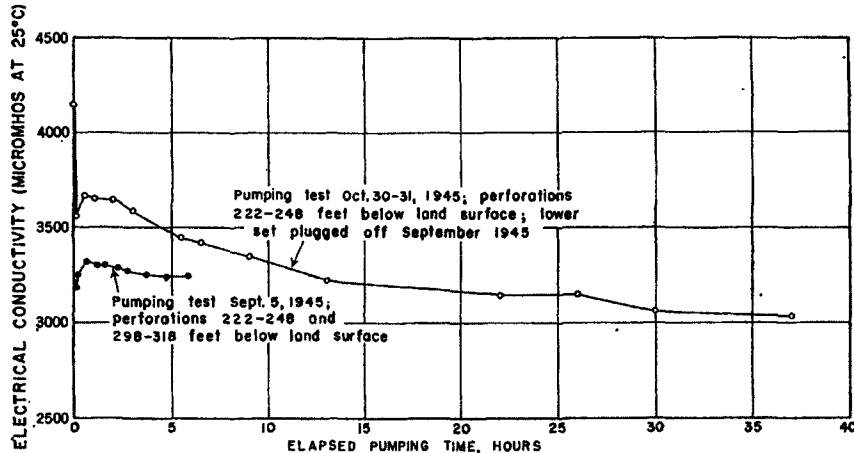

FIGURE 19.—Character of water discharged from well 3/15-12L6 (city of El Segundo, well 7) during pumping tests of September 5 and October 30-31, 1945.

obtained from two separate tests, on September 5 and October 30-31, 1945. During the test on September 5, the well yielded water through perforations from 222 to 248 feet and from 298 to 318 feet below land surface. The lower perforations were then plugged, and during the test of October 30-31 the well yielded water from only the shallower of the two water-bearing zones. The test of September 5 is believed to have been too short for the water from the well to have reached constant quality. During the pumping test of October 30-31 the water yielded initially was poorer but after 13 hours of continuous pumping it was of better quality than that yielded during the short span of the September test. The graphs are not conclusive but the results are included here as a matter of record.

#### WELL FIELDS OF THE STANDARD OIL CO. AND OF THE GENERAL CHEMICAL CO. AT EL SEGUNDO

The well field of the Standard Oil Co. of California is between El Segundo Boulevard and Rosecrans Avenue and is west of Sepulveda Boulevard, in sec. 13, T. 3 S., R. 15 W. Immediately east of Sepulveda Boulevard, in 3/14-18N, are the wells of the General Chemical Co. These two well fields are treated together here because they tap the same water-bearing zones, and conditions of contamination are common to both.

In this area, wells tap both the "200-foot sand" of upper Pleistocene age and the Silverado water-bearing zone of the San Pedro formation (pl. 3C). The "200-foot sand" here is about 20 feet thick, and its top is about 150 feet below the land surface and 50 feet below sea level. Commonly it is separated from the underlying Silverado water-bearing zone by 20–30 feet of impervious silt or clay.

The Silverado water-bearing zone in sec. 13 ranges in over-all thickness from about 150 feet in the northwestern part to about 250 feet in the eastern part (along Sepulveda Boulevard). This thickness includes beds of silt or clay of irregular occurrence. In general, the Silverado zone here spans three more or less distinct parts, which in downward succession are: (1) the principal water-bearing member, which is chiefly sand and gravel and about 100 feet thick; (2) an interbed of silt or clay from 20 to 50 feet thick; and (3) a basal member, which consists of alternating thin layers of sand, gravel, and silt, about 100 feet thick. The bottom of the Silverado zone is about 300 feet below sea level along Sepulveda Boulevard (pl. 2). Logs of wells in 3/15–13D and 14A, about 0.7 mile from the coast, suggest that the basal member grades westward into a layer of nearly uniform silt, and that the thickness of the upper member of the Silverado zone decreases to about 70 feet; the character of the zone here is similar to that at the main well field of Manhattan Beach, 2.4 miles southeast.

#### SUMMARY OF NATIVE WATER QUALITY

In the "200-foot sand," water is inferred to have been somewhat inferior under native conditions. As of 1903–4, a well in the southeast angle of the intersection of Rosecrans Avenue and Sepulveda Boulevard (Redondo, no. 150), which tapped the "200-foot sand," yielded water containing 630 ppm of dissolved solids. This well was about 1.4 miles inland from the ocean. Because of the comparatively poor quality of water in the "200-foot sand" in this area, it has been tapped by few wells. For the well fields here discussed, only three are known to have yielded water from this zone—wells 3/14–18N3 and 18N4 of the General Chemical Co. and well 3/15–13H1 of the Standard Oil Co. All other wells of these two companies tap solely the Silverado water-bearing zone; some tap the upper part, some the basal part, and some tap both.

In the Silverado water-bearing zone, under native conditions, two somewhat distinct water types existed in sec. 13, T. 3 S., R. 15 W. In the western part of sec. 13 and in the northeastern part of sec. 14, the native water was similar to but perhaps of somewhat poorer quality than that at the city of El Segundo main well field. Both waters contained about 400 ppm of dissolved solids, were calcium, sodium bicarbonate waters and contained substantially equal quan-

tities of chloride; however, the waters at the Standard Oil Co. field may have been somewhat higher in bicarbonate, with a corresponding increase in calcium and sodium. In the eastern part of sec. 13, where nearly all the producing wells of the company are now located, the native water was of somewhat better quality than those described above. These native waters ranged from sodium, calcium bicarbonate to sodium bicarbonate in character and contained from 330 to 375 ppm of dissolved solids and from 50 to 60 ppm of chloride. This difference in quality in the two parts of the field is presumed to result from the deeper penetration of wells in the eastern portion of the section; these waters from the deeper part of the range penetrated agree closely in quality with those that have been yielded from the Silverado water-bearing zone to the east. With respect to sulfate content, a slight difference existed in native waters from the two parts of the field. To the west, they contained about 15 ppm; to the east, the content was probably less than 10 ppm in the upper part and was negligible in the lower part of the range penetrated.

#### HISTORY OF WELL DRILLING AND ABANDONMENT

Since the first two wells of the Standard Oil Co. were placed in operation in 1914, withdrawal of water from the field has been continuous and has increased in quantity until, as of 1945, the 11 active wells yielded 4,780 acre-feet of water. Table 23 lists the 25 wells drilled by the company before 1946 and shows their status as of January 1946 and the chloride content of their water. For the six producing wells abandoned by 1930, the latest analysis indicated chloride in excess of 200 ppm in each; for the five wells abandoned from 1930 to 1946, only one appears to have yielded water containing more than 200 ppm of chloride at the time of abandonment. At least three of the latter group were abandoned because of mechanical difficulties or gradually diminishing yield. Although the various reports seem inconclusive, it appears that company wells 1 to 8 were abandoned because of excessive salinity. By 1922 salinity became apparent in this area, several years earlier than anywhere else along the coast. For the contaminated but still active wells along the east edge of sec. 13, the salinity increase is only slight; generally an increase in dissolved solids of not more than 25 percent has occurred.

#### CHEMICAL FEATURES OF CONTAMINATION

A study of the analytical data available for the wells in sec. 13, T. 3 S., R. 15 W., and also for those adjacent to the east, has disclosed that the contaminated waters there are of two general types with respect to change in chemical character and time of such change.

TABLE 23.—History and chloride content of wells at the Standard Oil Co., El Segundo refinery

| Well    |                   | Date drilled      | Chloride content (parts per million) |                   |         |       | Date abandoned   |
|---------|-------------------|-------------------|--------------------------------------|-------------------|---------|-------|------------------|
| Company | USGS <sup>1</sup> |                   | Initial <sup>2</sup>                 | Date              | Latest  | Date  |                  |
| 1.....  | 3/15-13D1.....    | 1911              | 102                                  | <sup>3</sup> 1921 | -----   | ----- | 1922             |
| 2.....  | 13D2.....         | 1911              | 188                                  | 1921              | 255     | 1921  | 1922             |
| 3.....  | 14A2.....         | 1917              | 90                                   | 1920              | 950-125 | 1923  | 1924             |
| 4a..... | 14A1.....         | <sup>4</sup> 1920 | -----                                | -----             | -----   | ----- | 1920             |
| 4b..... | 13E1.....         | 1920              | 89                                   | 1921              | 2,400   | 1930  | 1930             |
| 5.....  | 13F1.....         | 1922              | 248                                  | 1922              | 664     | 1929  | 1929             |
| 6.....  | 13G1.....         | 1923              | 58                                   | 1924              | 194     | 1942  | 1943             |
| 7.....  | 13G2.....         | 1928              | 118                                  | 1928              | 620     | 1939  | 1939             |
| 8.....  | 13F2.....         | 1929              | 610                                  | 1929              | 505     | 1929  | 1929             |
| 9.....  | 13R1.....         | 1930              | 60                                   | 1930              | 60      | 1943  | 1944             |
| 10..... | 13A1.....         | 1930              | 92                                   | 1930              | 92      | 1940  | 1940             |
| 11..... | 13J1.....         | 1935              | 92                                   | 1935              | 202     | 1945  | ( <sup>5</sup> ) |
| 12..... | 13H1.....         | 1937              | 86                                   | 1937              | 198     | 1944  | 1944             |
| 13..... | 13A2.....         | 1939              | 96                                   | 1939              | 224     | 1944  | ( <sup>5</sup> ) |
| 14..... | 13H2.....         | 1940              | 102                                  | 1940              | 70      | 1946  | ( <sup>5</sup> ) |
| 15..... | 13A3.....         | 1941              | 86                                   | 1941              | 160     | 1945  | ( <sup>5</sup> ) |
| 16..... | 13R2.....         | 1941              | 170                                  | 1941              | 104     | 1946  | ( <sup>5</sup> ) |
| 17..... | 13R3.....         | 1941              | 86                                   | 1941              | 141     | 1946  | ( <sup>5</sup> ) |
| 18..... | 3/14-19C1.....    | 1943              | 121                                  | 1943              | 112     | 1946  | ( <sup>5</sup> ) |
| 19..... | 3/15-13R4.....    | 1943              | 72                                   | 1943              | 109     | 1946  | ( <sup>5</sup> ) |
| 20..... | 13R5.....         | 1944              | 68                                   | 1944              | 75      | 1946  | ( <sup>5</sup> ) |
| 21..... | 13J2.....         | 1944              | 83                                   | 1945              | 92      | 1946  | ( <sup>5</sup> ) |
| 22..... | 13R6.....         | 1945              | 70                                   | 1945              | 68      | 1946  | ( <sup>5</sup> ) |
| 23..... | 13J3.....         | 1945              | 97                                   | 1945              | 119     | 1946  | ( <sup>5</sup> ) |
| 24..... | 13A4.....         | 1945              | 95                                   | 1946              | -----   | ----- | ( <sup>5</sup> ) |

<sup>1</sup> United States Geological Survey.

<sup>2</sup> Earliest analysis available.

<sup>3</sup> An analysis is available in which the chloride content is 91 ppm; date of analysis unknown.

<sup>4</sup> Abandoned after construction because of insufficient thickness of water-bearing strata.

<sup>5</sup> Presumed inactive, but status not known definitely.

<sup>6</sup> Presumed active as of Jan. 1, 1946.

1. In several of the earlier wells, notably 3/15-13E1, 13F1, and 14A2, contamination occurred at a comparatively early date and was characterized by a somewhat sudden increase of chloride and sulfate and by an increase in dissolved solids to more than 5,000 ppm.

2. In the wells just west of Sepulveda Boulevard, contamination has occurred to only a slight degree and is characterized by a small increase in chloride, by only a small increase in sulfate, and by a suggested concurrent but irregular decrease in bicarbonate.

These two water types will be described separately and graphs will be presented to show how contamination has occurred in each case.

For the first type, in which sulfate has increased markedly, figure 20 shows the extent to which sulfate and chloride increases are coincident with the advance of contamination. To show that the sulfate content of these waters is more than that which could have been brought in by sea water, figure 21 gives chloride and sulfate analyses plotted graphically for well 13G2, also the hypothetical content of

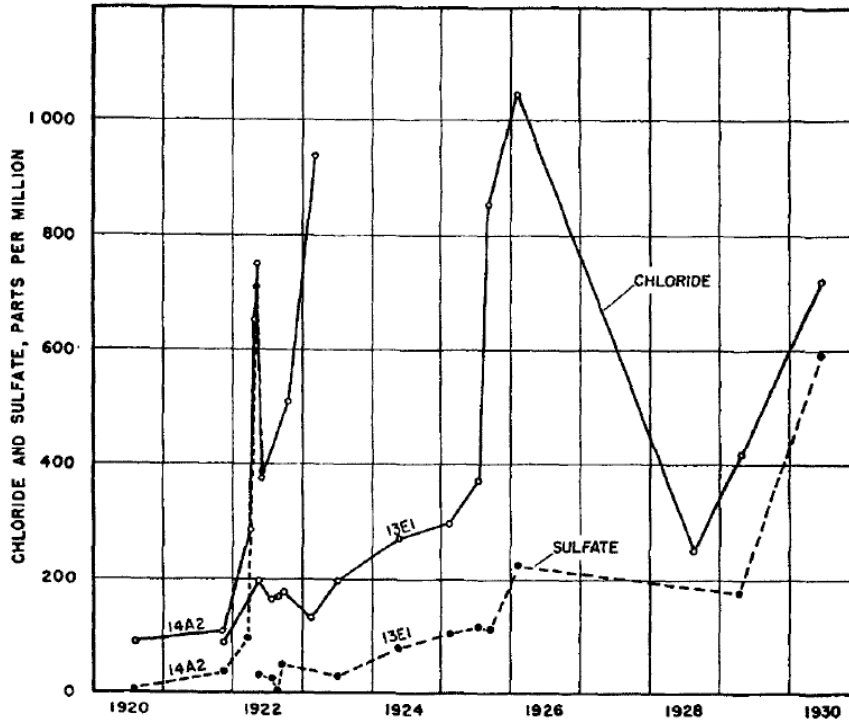

FIGURE 20.—Chloride and sulfate content of progressively contaminated waters from wells 3/15-13E1 and 14A2 (Standard Oil Co. wells 4b and 3).

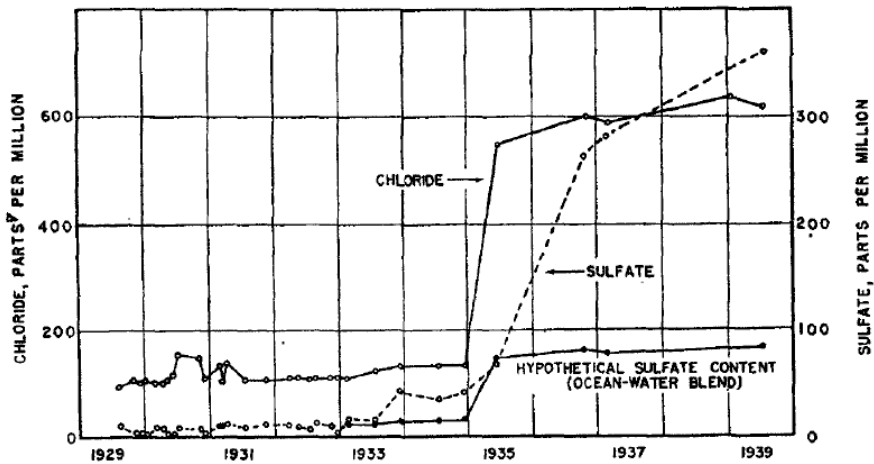

FIGURE 21.—Chloride content and actual and hypothetical sulfate content of progressively contaminated waters from well 3/15-18G2 (Standard Oil Co. well 7).

sulfate in the contaminated water if sea water had been the sole contaminant. The graph for this well shows that sulfate increase began in 1933; definite chloride contamination began in 1935. As of 1939, the increase in sulfate was about five times as great as that which would have been brought in by sea water. Obviously a high-sulfate contaminant must have contributed to the deterioration of the water in these wells.

The Standard Oil Co. conducted pumping tests in 1923, 1929, and 1930, respectively, for three wells that yielded contaminated water at an early date—3/15-14A2, 13F2, and 13E1; a series of water samples was collected from each of the wells until the quality of the effluent became constant. Each well tapped the Silverado water-bearing zone. Figure 22 shows the chloride analyses plotted for the three wells. Presumably, the pump had been idle for several days prior to each test. The following facts are significant:

1. The water yielded initially from each well was highly contaminated, but the water taken in the succeeding samples improved substantially in quality.
2. For each well, the water representative of the Silverado water-bearing zone at the time of the test contained less than 350 ppm of chloride; this water was yielded only after extended pumping—8 hours for well 13E1 and about 160 hours for well 14A2.

Accordingly, it is inferred that the water causing the contamination was coming from a source outside the Silverado zone; and that, while each pump was idle, a relatively small amount of the contaminant moved through the well casing and collected within the Silverado zone immediately outside the well casing. With continued pumping, the supply of concentrated contaminant was exhausted, and the water then yielded indicated the concentration of the regional contaminant in the Silverado zone. If the more concentrated contaminant had been invading the Silverado zone directly, the water quality would have deteriorated or remained about constant during prolonged pumping, because the saline water would have been replenished as rapidly as it was withdrawn. Contamination of this nature has been encountered in Santa Ana Gap and was described in an earlier report (Piper, Garrett, and others, 1953, p. 115-118).

The graph for well 14A2 in 1923 shows a regionally contaminated water containing about 120 ppm of chloride—little more than the native chloride concentration of about 90 ppm. For the three wells, a local source of contamination apparently supplied a small amount of highly saline water; the water yielded after prolonged pumping reflects the regional contamination in the Silverado zone, which contained less than 200 ppm of chloride in the middle twenties and 200 to 400 ppm about 1930. It is inferred that the more concentrated contaminant withdrawn through the wells during the first hours of



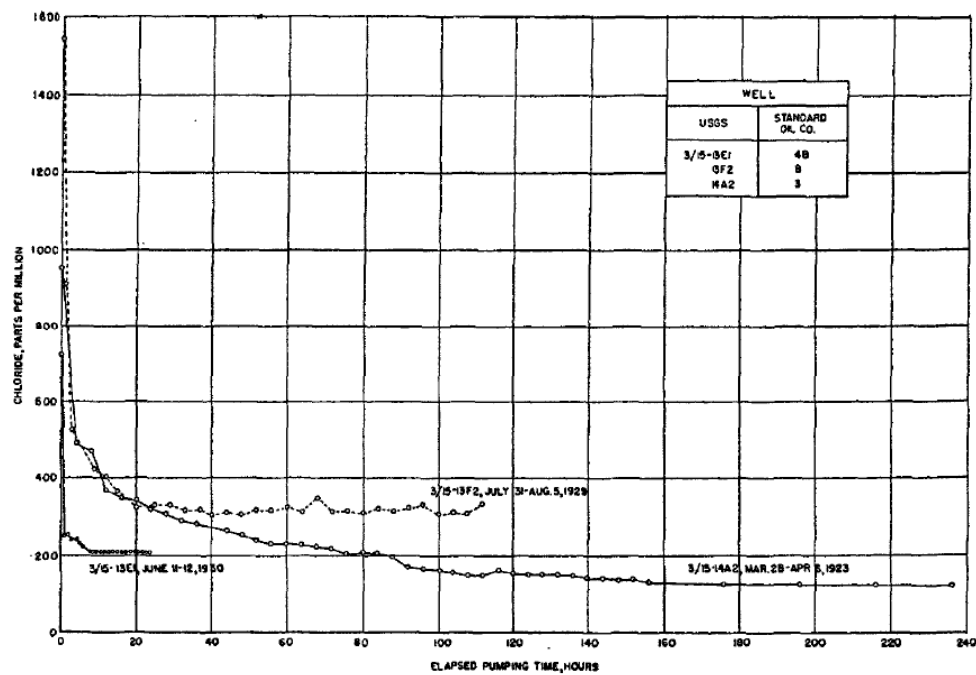

FIGURE 22.—Chloride content of waters from wells 3/5-13E1, 13F2, and 14A2, in relation to duration of pumping.

pumping must have entered the Silverado zone by passing down through the well casings from the overlying "200-foot sand." Because the well casings were not perforated opposite this overlying aquifer, the concentrated contaminant must have entered the casing through leaks.

As a further demonstration of the type of contamination occurring here locally, table 24 compares the contaminated water from well 3/15-13E1 with a hypothetical water formed by a mixture of ocean water and a native water to the same chloride content. The table shows that a large excess of sulfate is present in the contaminated water, also that a large excess of calcium and magnesium is present above that which could be accounted for solely by base exchange following ocean-water contamination. The excess of calcium and magnesium amounts to 14.13 equivalents per million, and is nearly equal to the sulfate excess of 14.26 equivalents per million. Hence, the local contaminant was doubtless a calcium sulfate or calcium, magnesium sulfate water at the time of mixture with the ground water.

TABLE 24.—Contaminated water from well 3/15-13E1 (Standard Oil Co., well 4b) in comparison with a hypothetical mixture of a presumed native water with ocean water

|                                                                                                      | Constituents (ppm) |                |             |                                 |                            |               |
|------------------------------------------------------------------------------------------------------|--------------------|----------------|-------------|---------------------------------|----------------------------|---------------|
|                                                                                                      | Calcium (Ca)       | Magnesium (Mg) | Sodium (Na) | Bicarbonate (HCO <sub>3</sub> ) | Sulfate (SO <sub>4</sub> ) | Chloride (Cl) |
| Parts per million:                                                                                   |                    |                |             |                                 |                            |               |
| Native water, well 3/15-13D1.....                                                                    | 54                 | 19             | 62          | 252                             | 12                         | 91            |
| Contaminated water, well 3/15-13E1; analysis of June 5, 1930.....                                    | 400                | 260            | 1,181       | 230                             | 1,020                      | 2,400         |
| Hypothetical mixture of ocean water with native water.....                                           | 96                 | 172            | 1,371       | 238                             | 335                        | 2,400         |
| Equivalents per million:                                                                             |                    |                |             |                                 |                            |               |
| Native water, well 3/15-13D1.....                                                                    | 2.70               | 1.56           | 2.69        | 4.13                            | 0.25                       | 2.57          |
| Contaminated water, well 3/15-13E1; analysis of June 5, 1930.....                                    | 19.96              | 21.38          | 51.36       | 3.77                            | 21.23                      | 67.70         |
| Hypothetical mixture of ocean water with native water.....                                           | 4.79               | 14.14          | 59.64       | 3.90                            | 6.97                       | 67.70         |
| Excess (+) or deficiency (-) of the contaminated water with respect to the hypothetical mixture..... | +15.17             | +7.24          | -8.28       | -1.13                           | +14.26                     | -----         |

For the wells along the eastern boundary of the Standard Oil Co. property, just west of Sepulveda Boulevard, contamination has been far less intensive, and at least three wells—3/15-13H2, J2, and R5—yielded essentially native water as of January 1946. Graphs showing the chloride content of waters from these wells have been presented on figure 23. Wells 3/15-13A1, A2, and A3 all tap essentially the entire thickness of the Silverado water-bearing zone, which here is only about 100 feet thick. The graph for well 13A1 suggests a slight but reasonably consistent increase in chloride from 1931 to 1939; those for

232 GEOLOGY, HYDROLOGY, TORRANCE-SANTA MONICA AREA

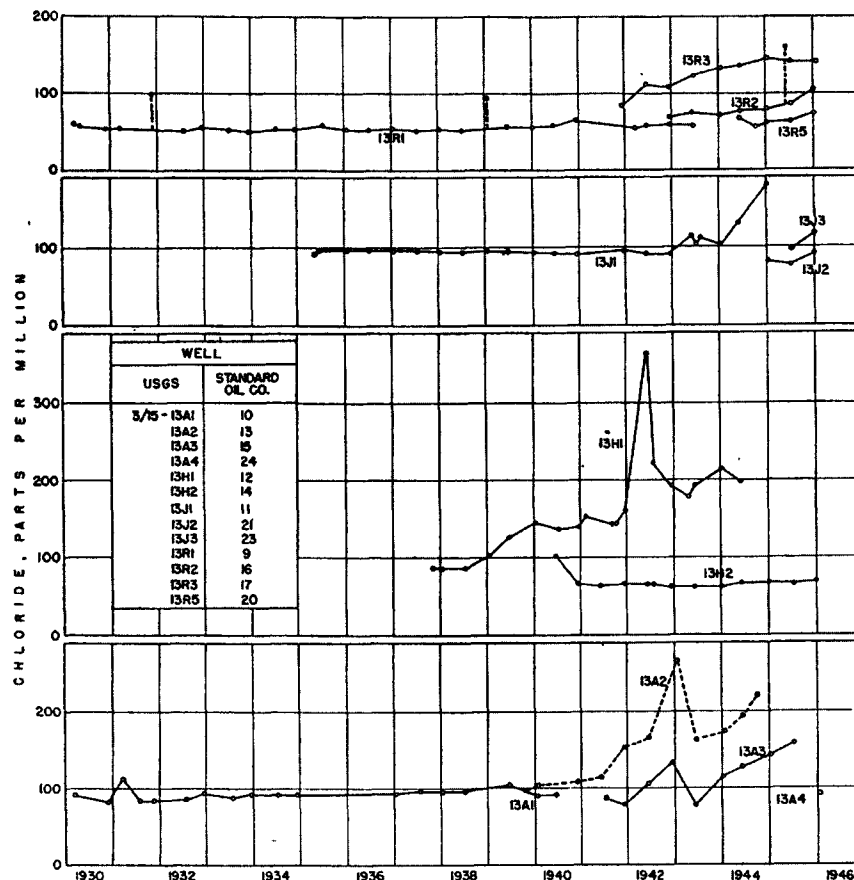

FIGURE 23.—Chloride content of waters from selected wells of the Standard Oil Co. at El Segundo.

wells A2 and A3 indicate a sharp increase in chloride in the early forties. The greatest recorded concentration of chloride for well 13A2—268 ppm—was accompanied by a sulfate content of 66 ppm; this is considerably more than that which could have been brought in with ocean water. For wells 3/15-13H1 and 13H2, the graphs show that definite contamination has occurred at well 13H1, and that well 13H2 yielded essentially native water as of January 1946. Well 13H1 taps the full range of the Silverado zone, and well H2 taps only the basal part. Thus, the contamination here is in the upper part of the Silverado zone.

Of the three wells 3/15-13J1, 13J2, and 13J3, well 13J1 taps the full thickness of the Silverado water-bearing zone, well 13J2 taps the middle part, and well 13J3 taps the middle and lower parts. Well 13J1 became contaminated in 1943, and the other two were incipiently contaminated in January 1946; here, also, the upper part of the Silver-

ado zone is the most saline. Of wells 3/15-13R1, 13R2, 13R3, and 13R5, well 13R1 taps about the middle part of the water-bearing zone, 13R2 taps only the lower part, 13R3 taps the upper part, and 13R5 taps both the middle and lower parts. The water from well 13R3 is the most saline; this fact indicates that here again the water in the upper part of the Silverado zone is markedly of poorer quality than that from the middle and lower parts. Contamination in the upper part of the zone in 13R began in late 1941, and therefore, it is roughly coincident with the onset of contamination adjacent to the north.

To the east, at the property of the General Chemical Co. in 3/14-18N, an analysis of water from well 18N3, in 1930, suggests that here, as to the west, waters contained about 60 ppm of chloride under native conditions. Of the three wells of the General Chemical Co. for which chemical analyses are available, wells 3/14-18N3 (company well 3) and 18N4 (company well 4) tap both the "200-foot sand" in the unnamed upper Pleistocene deposits and the Silverado water-bearing zone beneath. Inferentially, well 18N5 also taps both zones. Because of the low chloride content of water initially yielded from 18N3 (about 60 ppm), that well probably drew most of its water from the Silverado zone and drew a comparatively minor part from the "200-foot sand."

To show the progress of contamination at the well field of the General Chemical Co., chloride determinations on waters from the three wells have been plotted on figure 24. The graph for well 18N3 indicates that contamination here reached a peak in 1940 and since then has decreased markedly; as of January 1946, water from these wells was only very slightly contaminated.

If the graphs of figure 24 are compared with those of figure 23, it will be noted that this contamination peak occurred not only in well 3/14-18N3, but also in wells 3/15-13A2, 13A3, and 13H1, of the Standard Oil Co.; for these latter three wells, however, the peak occurred about in 1942, 2 years later than in well 18N3. This contamination seems to be superimposed on a regional trend toward increasing ground-water salinity which, as of 1945-46, was only moderate. In an attempt to discover whether this superimposed contamination showed a sulfate-chloride pattern similar to that in several of the early wells of the Standard Oil Co. (fig. 21 and p. 231), computations were made to determine, for periods of peak salinity, whether more sulfate had entered the wells than could be accounted for if sea water were the sole contaminant. The data concerning sulfate excess or deficiency for the four wells is given in table 25. The data contained therein indicate that the sulfate content during peak salinity was in excess of that to be expected from an ocean-water blend, and that the sulfate-chloride pattern was essentially

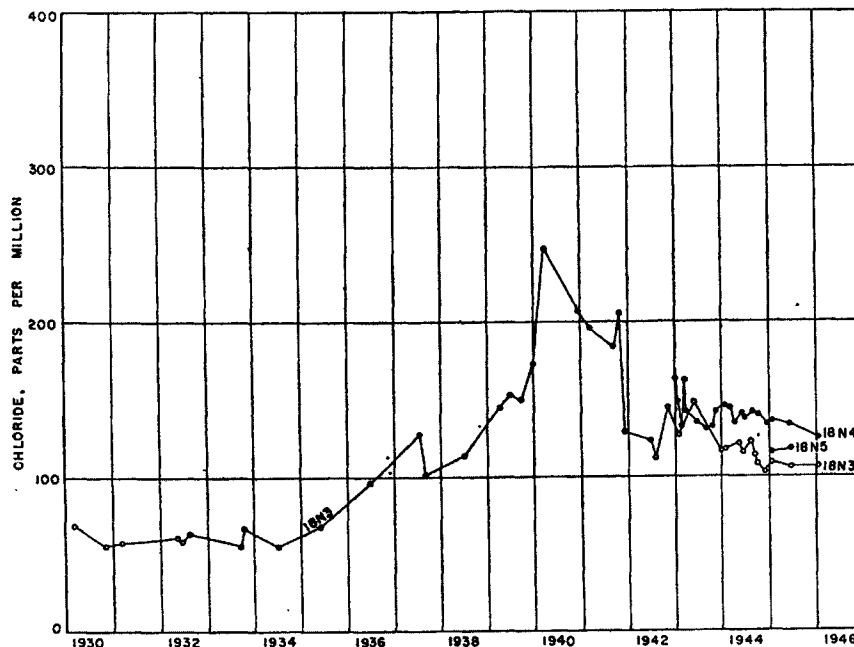

FIGURE 24.—Chloride content of waters from wells 3/14-18N3, 18N4, and 18N5 (General Chemical Co., wells 3, 4, and 5).

similar to that of the earlier contaminant in wells 3/15-13E1 and 14A2, about a mile to the west. For wells 3/15-13A2, A3, and H1 (fig. 23), the chloride peaks of 1942 had essentially disappeared as of mid-1943, and for each well the chloride concentration had returned to the projected normal increase in regional contamination. Furthermore, the abnormal chloride concentration began and ended within a period of 2 years in wells 13A2 and A3 and within one year in well 13H1.

For well 3/14-18N3, the chloride peak of 1940 had essentially disappeared as of 1942. However, as shown by figure 24, the chloride content of waters from the wells of the General Chemical Co. continued to decrease from 1942 into 1946, this fact indicates that the regional contamination front had not yet reached this well field by the end of 1945. Also, as of 1945, the sulfate content of water from the General Chemical Co. wells was only slightly greater than normal; this indicates that the local contaminant has been almost entirely removed or dissipated.

Probably this high-sulfate contaminant is not the cause of the regional contamination, which has progressed much more gradually, and which, for the active wells near Sepulveda Boulevard, has resulted in a maximum concentration only slightly in excess of 200

TABLE 25.—Sulfate content of contaminated water from certain wells in sec. 18, T. 3 S., R. 14 W., and sec. 13, T. 3 S., R. 15 W., in comparison with hypothetical sulfate content resulting from mixture of a presumed native water with ocean water

| Well           | Analysis (parts per million) |               |                            | Sulfate content resulting from mixture with sea water (parts per million) <sup>1</sup> | Excess (+) or deficiency (-) of the contaminated water with respect to the hypothetical mixture (percent) |
|----------------|------------------------------|---------------|----------------------------|----------------------------------------------------------------------------------------|-----------------------------------------------------------------------------------------------------------|
|                | Date                         | Chloride (Cl) | Sulfate (SO <sub>4</sub> ) |                                                                                        |                                                                                                           |
| 3/14-18N3..... | Apr. 24, 1940                | 246           | 43                         | 31                                                                                     | +39                                                                                                       |
| 3/15-13A2..... | Jan. 23, 1943                | 268           | 66                         | 34                                                                                     | +94                                                                                                       |
| 13A3.....      | Dec. 22, 1942                | 134           | 13                         | 15                                                                                     | -13                                                                                                       |
| 13H1.....      | June 24, 1942                | 364           | 64                         | 48                                                                                     | +33                                                                                                       |

<sup>1</sup> Based on a native water with presumed chloride and sulfate content of 60 and 5 ppm, respectively.

ppm of chloride—in wells 3/15-13A2. As for the wells of the city of El Segundo, ocean-water intrusion is inferred to have caused the regional contamination, although the change in chemical character of the contaminated waters from the wells near Sepulveda Boulevard has not been great enough to furnish diagnostic proof of such a source.

The source of the high-sulfate contaminant is not known. However, from the occurrence and movement of this contaminant, as described in previous pages, it is inferred that it originated at or near land surface. If waste water containing sulfuric acid were discharged at land surface, it would be neutralized by downward percolation through the soil zone and surface deposits, and it would pick up calcium and, to a lesser degree, magnesium (p. 231).

From land surface to a depth of about 140 feet, the underlying deposits are permeable dune sand or beach deposits, which rest upon the "200-foot sand" of upper Pleistocene age. Well logs indicate that a bed of silt, 10 to 30 feet thick, underlies the "200-foot sand" and separates it from the Silverado zone beneath. Thus, some of the water discharged at land surface doubtless could have seeped through the dune sand to the "200-foot sand" and could then have moved laterally on top of the subjacent silt bed. The lateral movement would have been in the direction of ground-water flow. Downward movement into the Silverado water-bearing zone would occur only where the silt bed was absent, or where it could move through defective well casings.

It is inferred that the high-sulfate contaminant, which has been described in waters from wells 3/15-13E1, 13F2, and 14A2 (p. 227), was derived by downward percolation to the "200-foot sand" and entered these wells through defective or leaky casings. It is inferred further that between the early twenties and the early forties, this high-sulfate contaminant migrated eastward about 1 mile to wells 3/15-13A2 and 13H1 (company wells 13 and 12). In 1935 the con-

taminant reached well 13G2 (fig. 23). Apparently, the "200-foot sand" is not present at well 13G2, and thus, the high-sulfate contaminant must have migrated into the upper part of the Silverado water-bearing zone before reaching this well. Doubtless at some place west of well 13G2 the "200-foot sand" is in direct hydraulic connection with the upper part of the Silverado zone.

Apparently, at the well field of the General Chemical Co. (3/14-18N) the bulk of contamination has entered the casings from the "200-foot sand," and the underlying Silverado water-bearing zone has been comparatively free of contamination. For example, a series of samples taken June 2, 1943, from well 3/14-18N3, during a 24-hour period of operation after a 3-month shutdown, yielded the following quantities of chloride: At start of test, 760 ppm; after pumping 1 hour, 360 ppm; after pumping 24 hours, 148 ppm. Presumably, a relatively small amount of contaminated water migrated downward through the well casing from the "200-foot sand" to the Silverado zone and was soon removed by pumping. (For a parallel example, see discussion of pumping tests of wells 3/15-13E1 and 14A2 (p. 229).)

#### WELL FIELD OF THE CITY OF MANHATTAN BEACH

Of the 11 public-supply wells of the city of Manhattan Beach, 6 were drilled in a small tract near the intersection of Eighth Street and Sepulveda Boulevard in the NE $\frac{1}{4}$  sec. 25, T. 3. S., R. 15 W. This tract, initially the only well field of the city, is 0.8 mile from the ocean and 1.3 miles south of the large well field of the Standard Oil Co. at El Segundo. With one exception, these six wells tap only the Silverado water-bearing zone, which here ranges in thickness from 30 feet (well 25H1) to 120 feet (well 25A3). That exception, well 3/15-25H1, taps 14 additional feet of coarse sand, 240 feet below the lower assigned limit of the Silverado water-bearing zone. Well 3/15-30D1 (city well 8), which is about 400 feet east of this well field, also taps the Silverado water-bearing zone.

The "200-foot sand" in the unnamed upper Pleistocene deposits was reported to be present in only one well at the main well field—no. 3/15-25H1 (city well 1)—but it was not tapped by that well. About 1 mile east, logs of three additional wells drilled by the city—wells 3/14-30H1, 30A2, and 29D3 (city wells 9, 10, and 11)—show that there the thickness of the Silverado water-bearing zone ranges from 120 feet in well 30H1 (city well 9) to 250 feet in well 29D3 (city well 11); the "200-foot sand" there has been tapped by well 30H1 but the other two wells tap only the Silverado zone.

#### SUMMARY OF NATIVE WATER QUALITY

Analyses of water from wells in the main field in 1930 indicate that the water in the Silverado water-bearing zone contained from 70 to

80 ppm of chloride and 20 to 35 ppm of sulfate. It is inferred that this water was essentially native. This inferred native water contained about 250 ppm of bicarbonate and 350 ppm of dissolved solids.

The chloride content of waters from six of the municipal wells has been plotted on figure 25. As shown by this figure, the chloride content of water from well 3/15-25A1 (city well 3) ranged from 76 to 120 ppm from 1929 to 1931; however, definite contamination did not develop until 1940 (in well 25H2). As of 1944, all wells in the main field yielded water containing more than 300 ppm of chloride.

By 1946 only wells 25A2 and A3 at the main field were still being utilized; both yielded water containing about 500 ppm of chloride. The three municipal wells near Aviation Boulevard, however, 3/14-29D3, 30A2, and 30H1, as of 1946 yielded native water of excellent quality. (See table 30.)

#### CHEMICAL FEATURES OF CONTAMINATION

To show the general change in chemical character of the waters at the main well field because of the progress of contamination, selected analyses have been plotted on figure 26. The graph indicates a trend characteristic of contaminated waters along the seaward margin of the coastal plain—that is, toward an increase in chloride, or chloride and sulfate, and with the ratio of sodium to calcium plus magnesium remaining more or less constant; for high-sodium contaminants, such as ocean water and oil-field brines, this approximately constant ratio could be explained only through ionic readjustment by base exchange. The starting point (well 3/14-30D1, analysis of Oct. 20, 1938) represents a water assumed to be essentially native. As revealed by the analytical data (table 30), the drift toward the apex of the graph has resulted almost entirely from an increase in chloride; sulfate has increased very slightly, and bicarbonate has decreased. The slight increase in sulfate renders unlikely the existence of a high-sulfate contaminant here. Thus, the two possible sources of contamination are oil-well brines and ocean water. The sulfate content of the progressively contaminated waters suggests that of the two sources, ocean water has been the source at this field (fig. 27). On this figure both chloride-bicarbonate and chloride-sulfate ratios have been plotted against the chloride content, as determined from all available complete analyses of the contaminated waters. Also plotted on the graph are the points showing, respectively, blends of an essentially native water with ocean water, and with a typical oil-well brine. The illustration shows two pertinent features:

1. The points representing the chloride-bicarbonate ratios of the well waters fall slightly closer to the line indicating the ocean-water blend than to that of the oil-field brine blend. For waters with chloride content of more than 450 ppm,



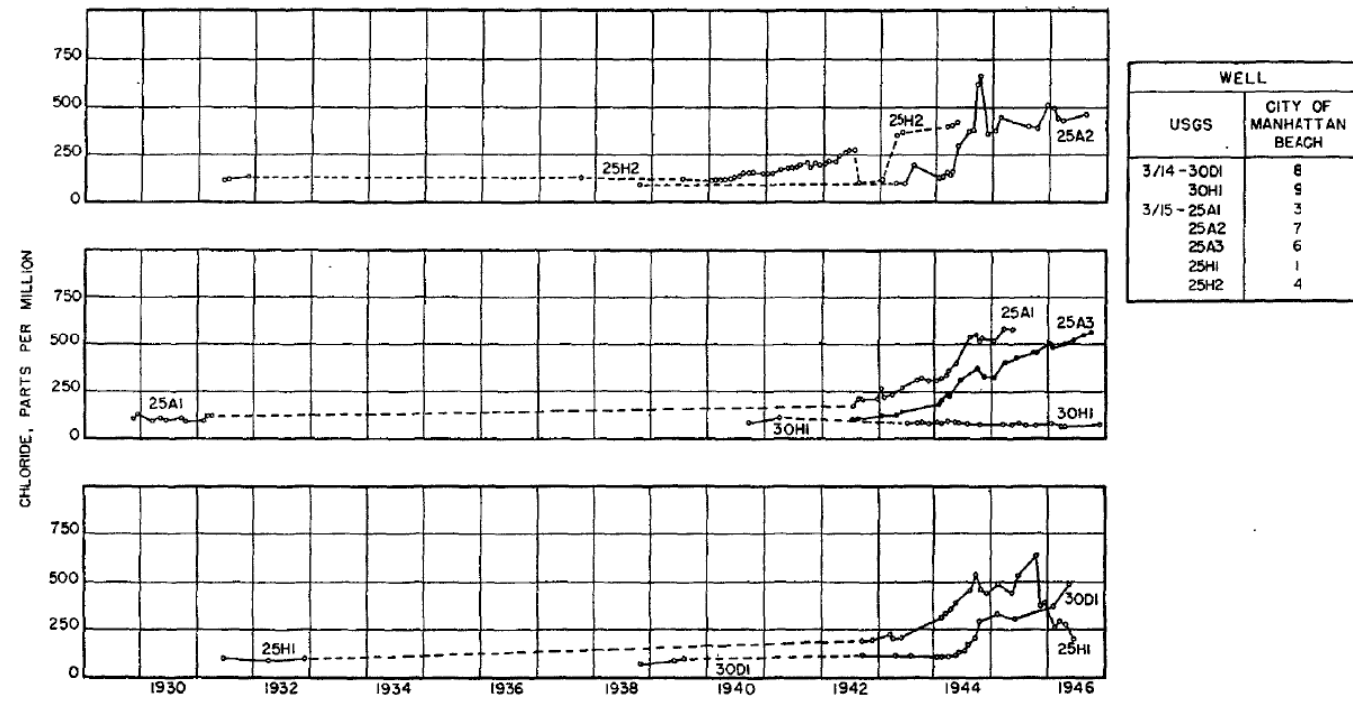
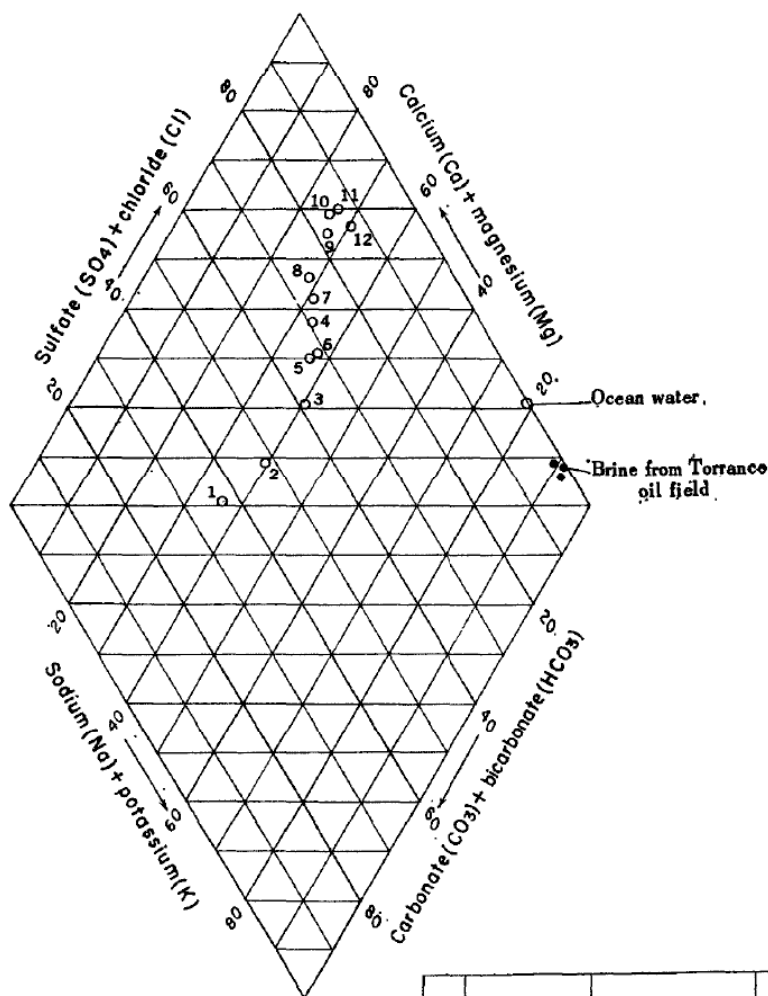

FIGURE 25.—Chloride content of waters from selected public-supply wells of the city of Manhattan Beach.



| No. | Well      | Date           | Chloride, parts per million |
|-----|-----------|----------------|-----------------------------|
| 1   | 3/14-30D1 | Oct. 20, 1938  | 67                          |
| 2   | 30D1      | Mar. 31, 1944  | 111                         |
| 3   | 30D1      | Aug. 15, 1944  | 172                         |
| 4   | 3/15-25H1 | June 11, 1943  | 203                         |
| 5   | 3/14-30D1 | Sept. 25, 1944 | 212                         |
| 6   | 30D1      | Oct. 24, 1944  | 226                         |
| 7   | 30D1      | Oct. 29, 1944  | 303                         |
| 8   | 30D1      | Feb. 5, 1946   | 371                         |
| 9   | 3/15-25A1 | Aug. 15, 1944  | 545                         |
| 10  | 25A1      | Sept. 25, 1944 | 561                         |
| 11  | 3/15-25A2 | Sept. 15, 1944 | 631                         |
| 12  | 25A2      | Sept. 25, 1944 | 677                         |

FIGURE 26.—Chemical character of contaminated waters from selected public-supply wells of the city of Manhattan Beach.

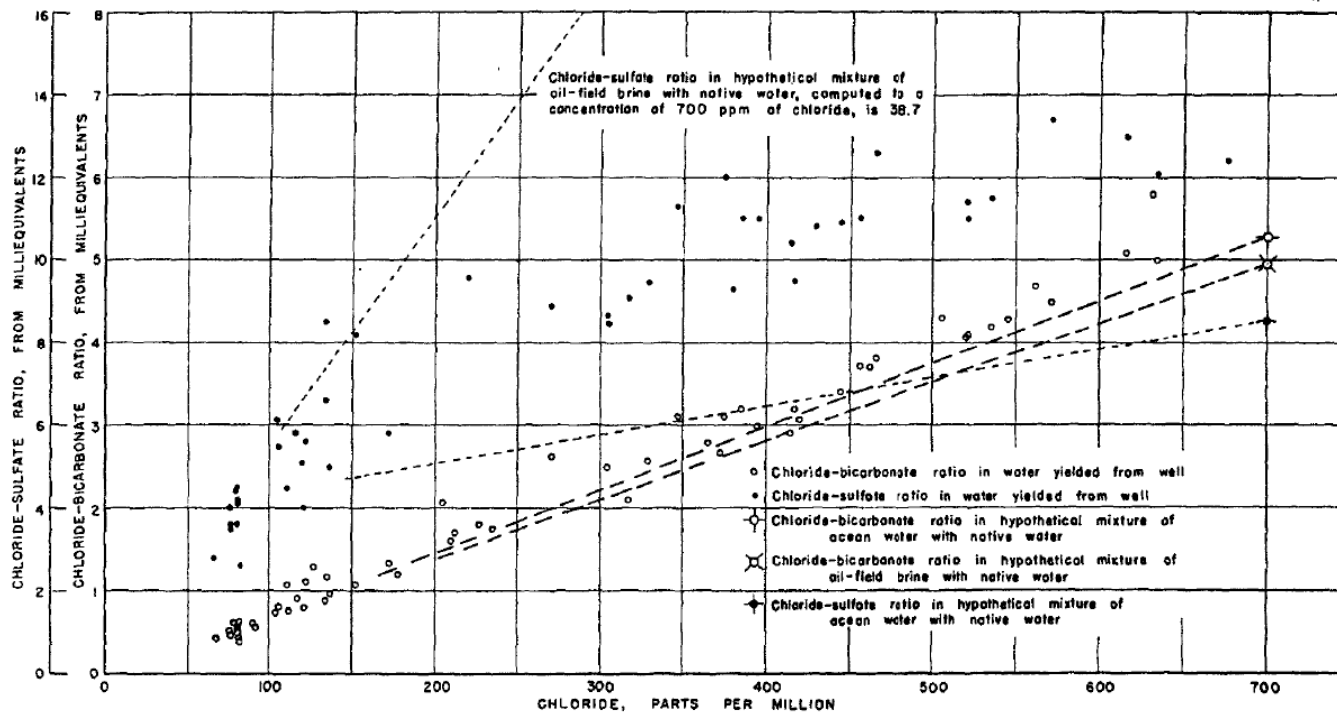

FIGURE 27.—Relationship of chloride, bicarbonate, and sulfate in contaminated waters from public-supply wells of the city of Manhattan Beach.

the digression of the plotted points from the ocean-water blend represents a decrease of bicarbonate amounting to about 7 percent. For the line indicating the oil-field brine blend the loss would have to be about 13 percent. However, this evidence certainly is not diagnostic with respect to selection between the two sources.

2. For values of chloride above 300 ppm the points representing the chloride-sulfate ratios of the well waters are alined much closer to the trend of the line indicating the ocean-water blend than to that of the oil-field brine blend. That is, the contaminated well waters contain much more sulfate than could have been brought in by oil-field brines, but slightly less than the computed amount carried in by ocean water. Of the two features, the chloride-sulfate ratio presents the only definite evidence of ocean-water contamination.

So far as is known from existing analytical data, brines from the western part of the Torrance oil field contain almost as much sulfate as the inferred native water at the main well field of the city of Manhattan Beach. Hence, waters contaminated with such a brine would be expected to show no increase in sulfate with increase in contamination. The analyses of the contaminated waters do show an increase in sulfate; however, this increase is less than that resulting from a simple blend of native water with ocean water, as shown by figure 27. This lack of agreement possibly could be explained to be a result of sulfate reduction if substantiating evidence could be found. However, because of the rapidity with which sulfate reduction may occur and the difficulty of obtaining confirmatory analyses, its occurrence at any given place is necessarily an inferential matter. However, not only does the sulfate content of these waters become greater with increase in contamination, but, as indicated by figure 27, the trend of the chloride-sulfate ratio is about parallel to the hypothetical chloride-sulfate ratio for a simple ocean-water mixture. Thus, it is concluded that ocean water is the contaminant at the Manhattan Beach well field.

#### VERTICAL RANGE OF CONTAMINATION

As described earlier, all wells at the main field of the city of Manhattan Beach, except well 25H1, yield from a single aquifer—the Silverado water-bearing zone. Well 25H1 taps both the Silverado zone and a 14-foot sand, 240 feet below that zone. In October 1944 and in January 1945, the Geological Survey made conductivity traverses in well 3/15-25H1 to determine: (1) if any range in quality existed between the waters yielded from the two zones; and (2) if any vertical range in quality existed in the water entering the casing through the perforations reported to be 221 to 240 feet below land surface opposite the Silverado zone. The data obtained from those traverses are shown on figure 28, from which the following conclusions have been drawn:

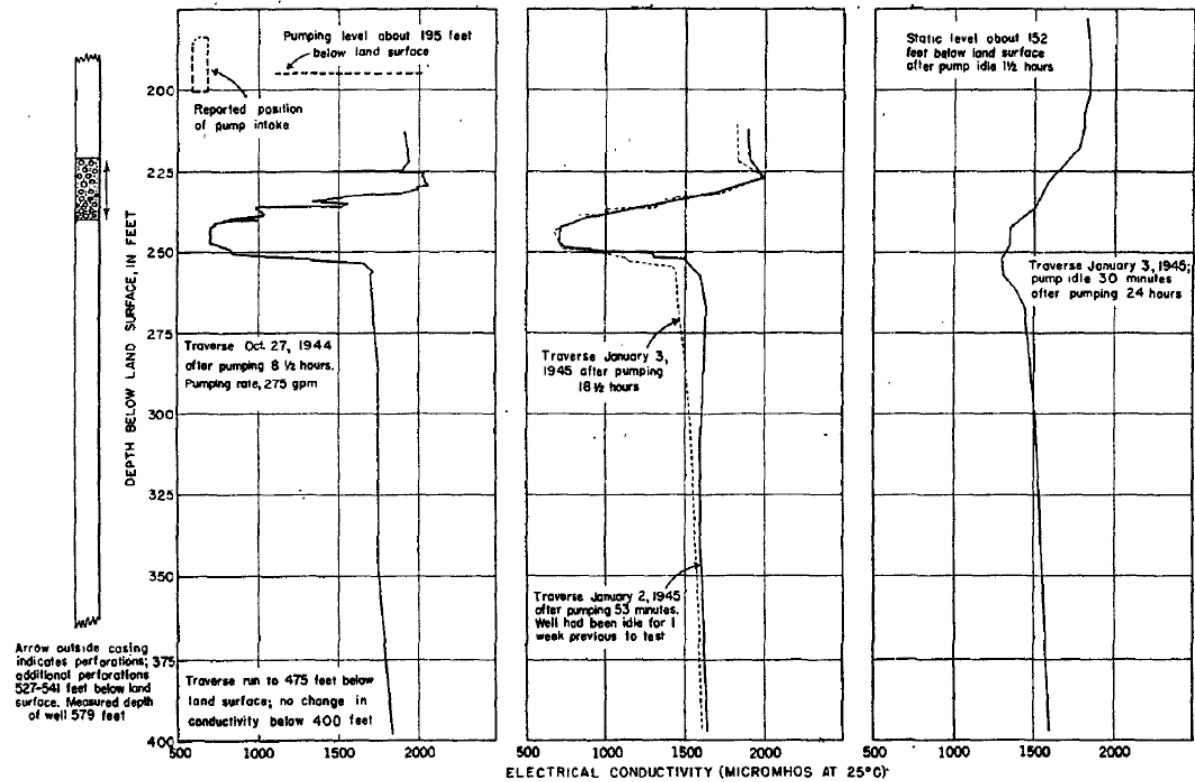

FIGURE 28.—Conductivity traverses in well 3/15-25H1 (city of Manhattan Beach well 1), Oct. 27, 1944, and Jan. 2-3, 1945.

1. The quality of the water from the deeper perforations (527-541 feet) was somewhat better than the water admitted to the pump intake. The amount of water yielded through these perforations was small, probably about 25 gpm.

2. Fresh water entered the well from 248 to 256 feet below land surface; there, the conductivity decreased from about 1,500 to 700 micromhos (dissolved solids about from 900 to 400 ppm). The casing reportedly is not perforated at this depth; thus the water must have entered either through unreported perforations or through a leaking casing.

3. Saline water entered the casing from 230 to 243 feet below land surface. The concentration of this water was indeterminate, but the conductivity was greater than 1,850 (dissolved solids greater than about 1,100 ppm).

4. Under nonpumping conditions, the saline water entering through the perforations 221-240 feet below land surface moved down to displace the fresh water at 248-256 feet and at 527-541 feet. Doubtless this saline fluid not only displaced the water in the casing, but it also invaded these lower water-bearing zones while the pump was idle.

#### WELLS IN AND NEAR REDONDO BEACH

To the south of 190th Street, near the coast, the Silverado water-bearing zone and the "200-foot sand" cannot be discriminated as separate entities. From here southward to the Palos Verdes Hills, the materials penetrated by wells are permeable throughout nearly their entire thickness (pl. 3C). Beneath the dune sand, which extends from land surface about to sea level, the water-bearing material tapped by wells is considered to be within the Silverado water-bearing zone. Wells have penetrated this zone to a depth as great as 400 feet below sea level (well 4/14-17E1 and 5N1). A comparison of drillers' logs of wells in the western part of sec. 8, T. 4 S., R. 14 W., suggests a local division of the Silverado zone into an upper and a lower part, separated by a few tens of feet of clay. Records of water levels in well 4/14-8E1, which taps only the upper part, and in well 8D1, which taps both the upper and lower parts, show little difference in altitude of water level in the two parts from the middle to the late thirties. Since about 1941, however, as shown by measurements at these two wells, the water level in the lower part has been slightly higher than that in the upper. Available chemical analyses suggest some slight difference in quality of water from the two parts; also, even where the separating clayey layer is not present, the deeper water is of appreciably better quality.

#### SUMMARY OF NATIVE WATER QUALITY

Water of native quality is represented by analyses of water from wells of the California Water Service Co. in sec. 31, T. 3 S., R. 14 W., and from random wells in secs. 5, 8, and 17, T. 4 S., R. 14 W. According to these analyses, the native waters contained 50 to 60 ppm of chloride, and about 300 to 360 ppm of dissolved solids; the sulfate content decreased from north to south. In sec. 31 the sulfate content

of these native waters was about 40 ppm; in sec. 5, from 15 to 12 ppm; in sec. 17, from about 7 ppm to only a trace. The native waters range from sodium, calcium-bicarbonate waters in the northern part of the area to sodium bicarbonate waters in the south. For the central part of the area, the analysis of October 6, 1931 of well 4/14-5N2 (table 30) has been selected to be representative of a native water of good quality. Locally, near the coast, inferior waters existed under native conditions according to early records. For example, by 1908, about half a mile from the coast in 4/14-7J, brackish water containing noticeable quantities of hydrogen sulfide gas was reported at depths of less than 185 feet below land surface. The water below that depth was utilized from about 1905 to 1930 by several public-supply wells of the California Water Service Co. It is reported to have been of good quality until it became contaminated late in the twenties.

#### PROGRESS OF WATER-QUALITY DEPRECIATION

The earliest known occurrence of water-quality depreciation in the Redondo Beach area is indicated by a series of analyses from well 4/14-6F1, which was drilled in 1912 by the Southern California Edison Co. The chloride content of the water from that well was 79 ppm. By late 1918 the chloride content had increased to 462 ppm. The public-supply wells of the California Water Service Co. in 4/14-7J were abandoned prior to 1931 because of saline contamination. Also, well 4/14-17E1, which was drilled in 1929 and perforated at intervals from 253 to 400 feet below land surface, yielded water containing 404 ppm of chloride in October of that year. Thus, as of 1930, the front of contaminated water extended inland at least 0.8 mile at Redondo Beach.

The general progress of contamination in the Redondo Beach area since 1930 is best shown by the chloride plots for several wells with good analytical records. These have been plotted on figure 29 and include well 4/14-5N2, which, since 1932, has an excellent record of chloride determinations made by the Los Angeles County Flood Control District. Definite contamination in this well began in 1938, and it increased so rapidly that the well was abandoned in 1945. Also plotted on figure 29 are chloride determinations on waters from wells 4/14-8D1 and 8E1, which were badly contaminated when abandoned in 1942 and 1943, respectively; well 8C1, which was incipiently contaminated as of 1946; and well 3/14-31A1, which in mid-1947 still yielded water of excellent quality. The trend of chloride for well 8C1 is anomalous; on the basis of trends shown by the chloride graphs for wells 5N2, 8D1, and 8E1, it would be expected that when the chloride content increased beyond 100 ppm, the slope of the curve would become much steeper and ultimately would result in the abandonment of