



**California Department of Fish and Wildlife
Inland Deserts Region
3602 INLAND EMPIRE BLVD. SUITE C-220
ONTARIO, CA91764**

California Endangered Species Act
Incidental Take Permit No. 2081-2020-037-06
(Amendment No. 2)

BALDY MESA SOLAR PROJECT

I. Authority:

This California Endangered Species Act (CESA) incidental take permit (ITP) is issued by the California Department of Fish and Wildlife (CDFW) pursuant to Fish and Game Code section 2081, subdivisions (b) and (c), and California Code of Regulations, Title 14, section 783.0 et seq. CESA prohibits the take¹ of any species of wildlife designated by the California Fish and Game Commission as an endangered, threatened, or candidate species.² However, CDFW may authorize the take of any such species by permit pursuant to the conditions set forth in Fish and Game Code section 2081, subdivisions (b) and (c). (See Cal. Code Regs., tit. 14, § 783.4).

Permittee:	Baldy Mesa Solar, LLC
Principal Officer:	Theresa Carroll
Contact Person:	Ariel Szymanski, (916) 580-9632
Mailing Address:	2180 S. 1300 E #500 Salt Lake City, UT 84106 aescepermitting@aes.com

II. Amended ITP³ Background

On July 29, 2020, Baldy Mesa Solar, LLC submitted a CESA ITP application to CDFW pursuant to Fish and Game Code section 2081, subdivisions (b) and (c), and California Code of Regulations Title 14, section 783.0 et. seq. Baldy Mesa Solar, LLC sought take coverage authorization for CESA listed species associated with Project-related impacts from the Baldy Mesa Solar Project (Project) in San Bernardino County.

On March 17, 2022, CDFW issued ITP No. 2081-2020-037-06 to Baldy Mesa Solar, LLC (Permittee), authorizing take of Agassiz’s desert tortoise (*Gopherus agassizii*), Mohave ground squirrel (*Xerospermophilus mohavensis*), and western Joshua tree (*Yucca brevifolia*) (collectively, the Covered

¹Pursuant to Fish and Game Code section 86, “‘take’ means hunt, pursue, catch, capture, or kill, or attempt to hunt, pursue, catch, capture, or kill.” (See also *Environmental Protection Information Center v. California Department of Forestry and Fire Protection* (2008) 44 Cal.4th 459, 507 [for purposes of incidental take permitting under Fish and Game Code section 2081, subdivision (b), “‘take’ ... means to catch, capture or kill”].)

²The definition of an endangered, threatened, and candidate species for purposes of CESA are found in Fish and Game Code sections 2062, 2067, and 2068, respectively.

³ When this incidental take permit and attachments refer to the “ITP”, it means the “Amended ITP” unless the context dictates otherwise.

Species) associated with and incidental to the Baldy Mesa Solar Project in San Bernardino County, California (Project). The Project as described in the ITP as originally issued by CDFW includes the construction of a ground-mounted, utility-scale solar energy and energy storage facility, with a generating capacity of up to 200 Megawatts (MW) located on approximately 1,197 acres. In issuing the ITP, CDFW found, among other things, that the Permittee’s compliance with the Conditions of Approval of the ITP would fully mitigate Project impacts of the taking on the Covered Species and that issuance of the ITP would not jeopardize the continued existence of the Covered Species.

ITP Condition of Approval 8 requires the permanent protection and perpetual management of compensatory habitat to mitigate for impacts to Covered Species, and that the mitigation must be complete within 18 months of the effective date of the ITP if Security is provided. The Permittee provided Security in the form of a letter of credit issued June 10, 2022. They have since been working to secure the required HM lands and have provided CDFW the preliminary information on proposed properties to fulfill the requirements.

Amendment No. 1

In an application submitted September 7, 2023, the Permittee requested an additional 12 months to complete the mitigation. The extension is needed due to initial difficulty and delays in securing biologically suitable mitigation lands for the Covered Species, as well as necessary CDFW reviews and approvals. The Permittee will continue the letter of credit that was issued as security until the land is secured and approved. On December 7, 2023, Minor Amendment 1 was executed to allow the Permittee a total of 30 months from the effective date of the original ITP to complete the mitigation.

Amendment No. 2

On January 25, 2023, the Permittee submitted a package of proposed lands to meet the mitigation requirement for desert tortoise and Mohave ground squirrel, which CDFW deemed biologically suitable in a letter dated July 14, 2023. On June 10, 2024, the Permittee submitted additional proposed lands to meet the requirement for western Joshua tree, which CDFW deemed biologically suitable in a letter dated July 26, 2024. On September 5, 2024, the Permittee submitted all of the additional required documentation for CDFW to review for property acceptance.

Due to the size of the mitigation package and time required for CDFW staff to complete final review and approval, CDFW has determined that an additional six months is warranted for the Permittee to complete their mitigation and remain in compliance with ITP Condition of Approval 8.

CDFW finds that this Amendment is a Minor Amendment, as defined in California Code of Regulations, title 14, section 783.6, subdivision (c)(4).

Issuance of this Amendment will not increase the amount of take of the Covered Species compared to the Project as originally approved, nor will this Amendment increase other Project impacts on the Covered Species (i.e., “impacts of taking” as used in Fish and Game Code Section 2081, subd. (b)(2)).

Incidental Take Permit
 No. 2081-2020-037-06
 (Amendment No. 2)
BALDY MESA SOLAR, LLC
BALDY MESA SOLAR PROJECT

Issuance of this Amendment does not affect CDFW's previous determination that issuance of the ITP meets and is otherwise consistent with the permitting criteria set forth in Fish and Game Code section 2081, subdivisions (b) and (c).

CDFW now reissues this ITP including the revised provisions in this Minor Amendment (Collectively, the Amended ITP). The Amended ITP includes all of the operative provisions as of the effective date of this Amended ITP. Attachment 9 to this Amended ITP shows the specific red-line changes made to the ITP as a result of this Minor Amendment

III. Effective Date and Expiration Date of this ITP:

The original ITP was executed in duplicate original form and became effective when a duplicate original was acknowledged by signature of the Permittee on the last page of the original ITP and returned to CDFW's Habitat Conservation Planning Branch at the address listed in the Notices section of this ITP. The original ITP's effective date was March 17, 2022. This remains the effective date for the original take authorization. The Amended ITP shall be executed in the same manner and shall become effective when signed by all parties and received by CDFW as described in the Notices section of this Amended ITP. Unless renewed by CDFW, this ITP and its authorization to take the Covered Species shall expire on **March 1, 2052**.

Notwithstanding the expiration date on the take authorization provided by this ITP, Permittee's obligations pursuant to this ITP do not end until CDFW accepts as complete the Permittee's Final Mitigation Report required by Condition of Approval 6.10 of this ITP.

IV. Project Location:

The Project is located in the northwestern portion of the City of Adelanto within the Mojave Desert. The main Project area is bounded by El Mirage Road on the south, Colusa Road on the north, extends 0.5 mile west of Richardson Road on the west, and to Raccoon Road on the east. The Project and gen-tie options are located in Sections 11–13 of Township 6 North, Range 6 West, and Sections 6, 7, 17-20, and 28-33 of Township 6 North, Range 5 West (San Bernardino Meridian) found on the U.S. Geological Survey (USGS) Adelanto and Victorville NW 7.5-minute topographic quadrangles (Exhibit A).

V. Project Description:

The proposed Project involves the construction of a ground-mounted, utility-scale solar energy and energy storage facility. The proposed Project would employ solar photovoltaic (PV) modules that convert sunlight directly into electrical energy. The proposed Project would have a generating capacity of up to 200 Megawatts (MW) located on approximately 1,197 acres.

Incidental Take Permit
No. 2081-2020-037-06
(Amendment No. 2)
BALDY MESA SOLAR, LLC
BALDY MESA SOLAR PROJECT

Solar Facility

A series of PV module arrays would be mounted on racking systems supported by a pile-driven foundation that would rotate east to west throughout the day. Electrical connections from a series of PV arrays would be channeled to combiner boxes located throughout the solar field. The underground electrical cables will be installed using standard trenching techniques, with directional boring techniques available to avoid sensitive resources, as necessary. The inverters will be fully enclosed and located adjacent to medium-voltage transformers, both of which will be installed on concrete foundations or elevated support structures. Switchgear cabinetry will also be installed for circuit control. Modules will be nonreflective and highly absorptive. The foundations are typically steel I-beams or piles driven into the soil using pneumatic or similar techniques for pile driving. The PV modules would have a typical height of 6 feet and a maximum height of approximately 12 feet, depending on the angle of the tracking system as it changes over the course of each day, and may be elevated in some isolated areas to avoid flood zones.

The substation will be located in the southeast region of the project site. The power will be delivered to the nearby SCE Roadway Substation located at the intersection of Delicious Street and Lawson Avenue via an approximate 5-mile 115 kV gen-tie. The Project also includes a battery electrical storage system (BESS) that would store up to +/- 100 MWAC of electricity for dispatch into the local SCE grid via the same point of interconnection as the solar array. The Applicant anticipates that the BESS would consist of between 15-30 battery storage containers, which would each house battery modules mounted in racks (akin to server racks) and associated electrical equipment. The BESS would have a SCADA system that would allow for remote monitoring and control of inverters and other proposed Project components.

VI. Covered Species Subject to Take Authorization Provided by this ITP:

This ITP covers the following species:

<u>Name</u>	<u>CESA Status⁴</u>
1. Agassiz’s Desert Tortoise (<i>Gopherus agassizii</i>)	Threatened ^{3a} Candidate ^{3b}
2. Mohave ground squirrel (<i>Xerospermophilus mohavensis</i>)	Threatened ^{3c}
3. Western Joshua Tree (<i>Yucca brevifolia</i>)	Candidate ^{3d}

These species and only these species are the “Covered Species” for the purposes of this ITP.

⁴ Incidental Take Permit

^{4a}See Cal. Code Regs. tit. 14 § 670.5, subd. (b)(4)(A).

^{3b}See 2020 Cal. Reg. Notice Register, No. 44-Z, pp. 1445-1446 (October 30, 2020).

^{3c}See Cal. Code Regs. tit. 14 § 670.5, subd. (b)(6)(A).

^{3d}See 2020 Cal. Reg. Notice Register, No. 41-Z, pp. 1349 (October 9, 2020)

VII. Impacts of the Taking on Covered Species:

Project activities and their resulting impacts are expected to result in the incidental take of individuals of the Covered Species. The activities described above expected to result in incidental take of individuals of the Covered Species include vegetation clearing; grading, leveling, and compaction; excavation; installation of fencing or barriers; installation and/or construction of temporary Project facilities and structures; general operation of vehicles and heavy equipment; noise, vibration, and dust generating activities; and capture and relocation activities (Covered Activities).

Incidental take of individuals of the Covered Species in the form of mortality (“kill”) may occur as a result of Covered Activities such as: collision with, or crushing by, vehicles or heavy equipment; crushing or burial of individuals or eggs in burrows; destruction of burrows and refugia; and increased predation. Incidental take of individuals of the Covered Species may also occur from the Covered Activities in the form of pursue, catch, capture, or attempt to do so of the Covered Species as well as, capture and relocation activities. More specifically, relocation of Covered Species out of harm’s way may disrupt the behavior and social structure of resident individuals. The areas where authorized take of the Covered Species is expected to occur is within the 1,197-acre area for the Project site and along the 5-mile-long gen-tie line (collectively, the Project Area).

The Project is expected to cause 74 acres of permanent impacts to habitat for the desert tortoise, 74 acres of permanent impacts to low-to-moderate habitat for Mojave ground squirrel, and a total of 692.1 acres of permanent impacts to western Joshua trees. Impacts of the authorized taking also include adverse impacts to the Covered Species related to temporal losses, increased habitat fragmentation and edge effects, and the Project’s incremental contribution to cumulative impacts (indirect impacts), removal of trees. These impacts include stress resulting from noise and vibrations, displacement from preferred habitat, increased competition for food and space, and increased vulnerability to predation.

VIII. Incidental Take Authorization of Covered Species:

This ITP authorizes incidental take of the Covered Species and only the Covered Species. With respect to incidental take of the Covered Species, CDFW authorizes the Permittee, its employees, contractors, and agents to take Covered Species incidentally in carrying out the Covered Activities, subject to the limitations described in this section and the Conditions of Approval identified below. This ITP does not authorize take of Covered Species from activities outside the scope of the Covered Activities, take of Covered Species outside of the Project Area, take of Covered Species resulting from violation of this ITP, or intentional take of Covered Species except for capture and relocation of Covered Species as authorized by this ITP.

IX. Conditions of Approval:

Unless specified otherwise, the following measures apply to all Covered Activities within the Project Area, including areas used for vehicular ingress and egress, staging and parking, and noise and vibration generating activities that may/will cause take. CDFW’s issuance of this ITP and Permittee’s

Incidental Take Permit
No. 2081-2020-037-06
(Amendment No. 2)
BALDY MESA SOLAR, LLC
BALDY MESA SOLAR PROJECT

authorization to take the Covered Species are subject to Permittee's compliance with and implementation of the following Conditions of Approval:

- 1. Legal Compliance:** Permittee shall comply with all applicable federal, state, and local laws in existence on the effective date of this ITP or adopted thereafter.
- 2. CEQA Compliance:** Permittee shall implement and adhere to the mitigation measures related to the Covered Species in the Biological Resources section of the Mitigated Negative Declaration (SCH No.: 2020090176) approved by the City of Adelanto on November 13, 2020, as lead agency for the Project pursuant to the California Environmental Quality Act (CEQA) (Pub. Resources Code, § 21000 et seq.).
- 3. LSA Agreement Compliance:** Permittee shall implement and adhere to the mitigation measures and conditions related to the Covered Species in the Lake and Streambed Alteration Agreement (LSAA) (Notification No. EPIMS-SBR-13456-R6) for the Project executed by CDFW pursuant to Fish and Game Code section 1600 et seq.
- 4. ITP Time Frame Compliance:** Permittee shall fully implement and adhere to the conditions of this ITP within the time frames set forth below and as set forth in the Mitigation Monitoring and Reporting Program (MMRP), which is included as Attachment 1 to this ITP.
- 5. General Provisions:**
 - 5.1. Designated Representative.** Before starting Covered Activities, Permittee shall designate a representative (Designated Representative) responsible for communications with CDFW and overseeing compliance with this ITP. Permittee shall notify CDFW in writing before starting Covered Activities of the Designated Representative's name, business address, and contact information, and shall notify CDFW in writing if a substitute Designated Representative is selected or identified at any time during the term of this ITP.
 - 5.2. Biological Monitor(s).** Permittee shall designate Biological Monitor(s) (Biological Monitor(s)) knowledgeable and experienced in the biology and natural history of the Covered Species. The Biological Monitor(s) shall be responsible for monitoring Covered Activities to help minimize and fully mitigate or avoid the incidental take of individual Covered Species and to minimize disturbance of Covered Species' habitat.
 - 5.3. Authorized Biologist.** Permittee shall designate Authorized Biologist(s) (Authorized Biologist(s)) knowledgeable in the biology and natural history of the Covered Species. The Authorized Biologist(s) shall be responsible for monitoring Covered Activities to help minimize and fully mitigate and avoid the incidental take of individual Covered Species and to minimize disturbance of Covered Species' habitat. Additionally, the Authorized Biologist(s) shall have experience with all activities that will be carried out for the Project

Incidental Take Permit
No. 2081-2020-037-06
(Amendment No. 2)
BALDY MESA SOLAR, LLC
BALDY MESA SOLAR PROJECT

including, but not limited to, excavating burrows, handling and temporarily holding the Covered Species, relocating/translocating the Covered Species, reconstructing Covered Species burrows, unearthing and relocating Covered Species eggs, locating, identifying, and recording all forms of Covered Species signs, collecting Covered Species blood samples, conducting Covered Species health assessments, conducting Covered Species protocol level surveys, and/or attaching and removing transmitters to and from the Covered Species.

- 5.4. Biologists and Veterinarians Approvals.** Permittee shall obtain CDFW approval of the Authorized Biologist(s), Biological Monitor(s), and if needed veterinarian(s), in writing before starting Covered Activities, and shall also obtain advance written approval if any of these entities are changed. For approval, the Designated Representative shall submit Attachment 2 of this ITP and an Excel spreadsheet listing in alphabetical order the names of the proposed Authorized Biologist(s), Biological Monitor(s), and veterinarian(s) to CDFW a minimum of 30 calendar days before starting Covered Activities or before any changes are made to these personnel. For each proposed Authorized Biologist(s) and Biological Monitor(s), the Excel spreadsheet shall include the activities outlined in this ITP and associated Desert Tortoise Translocation Plan (DTTP) that the Permittee is requesting approval for that individual to carry out.
- 5.5. Authorized Biologist(s) and Biological Monitor(s) Authority.** To ensure compliance with the Conditions of Approval of the ITP, the Biological Monitor(s) and/or Authorized Biologist(s) shall have authority and take necessary steps to immediately stop work if any activity does not comply with this ITP and/or Authorized Biologist(s) shall order any reasonable measure to avoid the unauthorized take of an individual of the Covered Species. If a Biological Monitor or Authorized Biologist stops work on the Project site, work shall not resume until an Authorized Biologist determines that all activities are in compliance with the ITP and communicates that determination to the onsite manager. Permittee shall inform all persons employed or otherwise working in the Project Area that the Biological Monitor(s) and Authorized Biologist(s) have the authority described in this subsection.
- 5.6. Education Program.** Permittee shall conduct an education program for all persons employed or otherwise working in the Project Area before performing any work. The program shall consist of a presentation from the Designated Biologist that includes a discussion of the biology and general behavior of the Covered Species, information about the distribution and habitat needs of the Covered Species, sensitivity of the Covered Species to human activities, its status pursuant to CESA including legal protection, recovery efforts, penalties for violations and Project-specific protective measures described in this ITP. Permittee shall prepare and distribute wallet-sized cards or a fact sheet handout containing this information for workers to carry in the Project Area. Permittee shall provide interpretation for non-English speaking workers, and the same instruction shall be provided to any new workers before they are authorized to perform work in the Project Area. Upon

completion of the program, employees shall sign a form stating they attended the program and understand all protection measures. This training shall be repeated at least once annually for long-term and/or permanent employees that will be conducting work in the Project Area. If the training program is presented as a prerecorded presentation, it shall be accompanied by a formal process that allows submission of questions that shall be answered by the Authorized Biologist(s) within 24 hours of submission.

- 5.7. Construction Monitoring Documentation.** The Biological Monitor(s) and Authorized Biologist(s) shall maintain construction-monitoring documentation on-site in either hard copy or digital format throughout the construction period, which shall include a copy of this ITP with attachments and a list of signatures of all personnel who have successfully completed the education program. Permittee shall ensure a copy of the construction-monitoring documentation is available for review at the Project site upon request by CDFW.
- 5.8. Trash Abatement.** Permittee shall initiate a trash abatement program before starting Covered Activities and shall continue the program for the duration of the Project. Permittee shall ensure that trash and food items are contained in animal-proof containers and removed, ideally at daily intervals but at least once a week, to avoid attracting opportunistic predators such as ravens, coyotes, and feral dogs.
- 5.9. Dust Control.** Permittee shall implement dust control measures during Covered Activities to facilitate visibility for monitoring of the Covered Species by the Designated Biologist. Permittee shall keep the amount of water used to the minimum amount needed and shall not allow water to form puddles.
- 5.10. Erosion Control Materials.** Permittee shall prohibit use of erosion control materials potentially harmful to Covered Species and other species, such as monofilament netting (erosion control matting) or similar material, in potential Covered Species' habitat.
- 5.11. Delineation of Property Boundaries.** Before starting Covered Activities along each part of the route in active construction, Permittee shall clearly delineate the boundaries of the Project Area with fencing, stakes, or flags. Permittee shall restrict all Covered Activities to within the fenced, staked, or flagged areas. Permittee shall maintain all fencing, stakes, and flags until the completion of Covered Activities in that area.
- 5.12. Delineation of Habitat.** Permittee shall clearly delineate habitat of the Covered Species within the Project Area with posted signs, posting stakes, flags, and/or rope or cord, and place fencing as necessary to minimize the disturbance of Covered Species' habitat.
- 5.13. Project Access.** Project-related personnel shall access the Project Area using existing routes, or routes identified in the Project Description and shall not cross Covered Species' habitat outside of or enroute to the Project Area; cross-country (off-road) vehicle travel

Incidental Take Permit
No. 2081-2020-037-06
(Amendment No. 2)
BALDY MESA SOLAR, LLC
BALDY MESA SOLAR PROJECT

shall be prohibited unless specifically accounted for as a Covered Activity. Permittee shall restrict Project-related vehicle traffic to established roads, staging, and parking areas. Project-related vehicle traffic shall not exceed 25 miles per hour, except in Covered Species habitat where vehicle speed shall not exceed 15 miles per hour. If Permittee determines construction of routes for travel are necessary outside of the Project Area, the Designated Representative shall contact CDFW for written approval before carrying out such an activity. CDFW may require an amendment to this ITP, among other reasons, if additional take of Covered Species will occur as a result of the Project modification.

- 5.14. Staging Areas.** Permittee shall confine all Project-related parking, storage areas, laydown sites, equipment storage, and any other surface-disturbing activities to the Project Area using, to the extent possible, previously disturbed areas. Additionally, Permittee shall not use or cross Covered Species' habitat outside of the marked Project Area unless provided for as described in Condition of Approval 5.11 of this ITP.
- 5.15. Hazardous Waste.** Permittee shall immediately stop and, pursuant to pertinent state and federal statutes and regulations, arrange for repair and clean up by qualified individuals of any fuel or hazardous waste leaks or spills at the time of occurrence, or as soon as it is safe to do so. Permittee shall exclude the storage and handling of hazardous materials from the Project Area and shall properly contain and dispose of any unused or leftover hazardous products off-site.
- 5.16. CDFW Access.** Permittee shall provide CDFW staff with reasonable access to the Project and mitigation lands under Permittee control and shall otherwise fully cooperate with CDFW efforts to verify compliance with or effectiveness of mitigation measures set forth in this ITP.
- 5.17. Refuse Removal.** Upon completion of Covered Activities, Permittee shall remove from the Project Area and properly dispose of all temporary fill and construction refuse, including, but not limited to, broken equipment parts, wrapping material, cords, cables, wire, rope, strapping, twine, buckets, metal or plastic containers, and boxes.
- 5.18. General Habitat and Species Avoidance.** Permittee shall, to the greatest extent feasible, avoid impacts/disturbances to sensitive plants, plant communities, and animals within the Project Area. In addition, Permittee shall avoid, to the maximum extent practicable, impacts/disturbance to perennial, native vegetation within the Project Area. To the maximum extent practicable, Permittee shall limit access-related Covered Activities to “drive and crush” rather than vegetation removal or grubbing.
- 5.19. Firearms and Dogs.** Permittee shall prohibit Project personnel and any other individuals associated with the Project from bringing any firearms or dogs on the Project Area during Covered Activities, except those in the possession of authorized security personnel or

Incidental Take Permit
 No. 2081-2020-037-06
 (Amendment No. 2)
BALDY MESA SOLAR, LLC
BALDY MESA SOLAR PROJECT

local, state, or federal law enforcement officials, dogs that may be used to aid in official and approved monitoring procedures/protocols, or service dogs under Title II and Title III of the American with Disabilities Act.

6. Monitoring, Notification and Reporting Provisions:

Notification Requirements

- 6.1. Notification Before Commencement.** The Designated Representative shall notify CDFW 14 calendar days before starting Covered Activities and shall document compliance with all pre-Project Conditions of Approval before starting Covered Activities.
- 6.2. Notification of Non-compliance.** The Designated Representative shall immediately notify CDFW if the Permittee is not in compliance with any Condition of Approval of this ITP, including but not limited to any actual or anticipated failure to implement measures within the time periods indicated in this ITP and/or the MMRP. The Designated Representative shall follow up within 24 hours with a written report to CDFW describing, in detail, any non-compliance with this ITP and suggested measures to remedy the situation.
- 6.3. Notification of Take or Injury.** Permittee shall immediately notify the Biological Monitor(s) and/or Authorized Biologist(s) if a Covered Species is taken or injured by a Project-related activity, or if a Covered Species is otherwise found dead or injured within the vicinity of the Project. The Biological Monitor(s), Authorized Biologist(s), or Designated Representative shall provide initial notification to CDFW by following Condition of Approval 6.5. The initial notification to CDFW shall include information regarding the location, species, and number of animals/plants taken or injured/damaged and the ITP Number. Following initial notification, Permittee shall send CDFW a written report within three calendar days. The report shall include the date and time of the finding or incident, location of the animal or carcass, and if possible, provide a photograph, explanation as to cause of take or injury, and any other pertinent information.
- 6.4. Future Take or Injury Prevention.** The Permittee shall develop and include measures that will be implemented to prevent or minimize future take or injury of Covered Species in all reports provided under Section 6.3 above.
- 6.5. Notifying Procedures.** The Permittee or the Designated Representative shall provide all required notifications in this ITP by sending an email to the CDFW Regional Representative Rose Banks (Rose.Banks@wildlife.ca.gov) and as described in the Notices section of this ITP. All notifications shall be submitted via email to the Regional Representative and shall include the following information: ITP Number, the ITP Condition number that the notification is addressing, any necessary photos or attachments, and the name and phone numbers of the Biological Monitor(s) and/or Authorized Biologist(s) (if applicable).

Incidental Take Permit
 No. 2081-2020-037-06
 (Amendment No. 2)
BALDY MESA SOLAR, LLC
BALDY MESA SOLAR PROJECT

Monitoring Requirements

6.6. Compliance Monitoring. The Biological Monitor(s) and/or Authorized Biologist(s) shall be on-site daily when Covered Activities occur. The Biological Monitor(s) and/or Authorized Biologist(s) shall conduct compliance inspections a minimum of to:

- (1) minimize incidental take of the Covered Species;
- (2) prevent unlawful take of species;
- (3) check for compliance with all measures of this ITP;
- (4) check all exclusion zones; and
- (5) ensure that signs, stakes, and fencing are intact, and that Covered Activities are only occurring in the Project Area.

The Designated Representative, Biological Monitor(s), and/or Authorized Biologist(s) shall prepare daily written observation and inspection records summarizing oversight activities and compliance inspections, observations of Covered Species and their sign, survey results, and monitoring activities required by this ITP. The Authorized Biologist(s) and/or Biological Monitor shall conduct compliance inspections a minimum of three times a day (once during the onset of the day's work, once mid-day, and once at the conclusion of that day's work).

Reporting Requirements

6.7. Quarterly Compliance Report. The Designated Representative, Biological Monitor(s), and/or Authorized Biologist(s) shall compile the observation and inspection records identified in Condition of Approval 6.6 into a Quarterly Compliance Report and submit it to CDFW along with a copy of the MMRP table with notes showing the current implementation status of each mitigation measure. Quarterly Compliance Reports shall be submitted to the CDFW offices listed in the Notices section of this ITP and via e-mail to CDFW's Regional Representative and Headquarters CESA Program. At the time of this ITP's approval, the CDFW Regional Representative is Rose Banks (Rose.Banks@wildlife.ca.gov) and Headquarters CESA Program email is CESA@wildlife.ca.gov. CDFW may at any time increase the timing and number of compliance inspections and reports required under this provision depending upon the results of previous compliance inspections. If CDFW determines the reporting schedule must be changed, CDFW will notify Permittee in writing of the new reporting schedule.

6.8. Annual Status Report. Permittee shall provide CDFW with an Annual Status Report (ASR) no later than January 31 of every year beginning with issuance of this ITP and continuing until CDFW accepts the Final Mitigation Report identified below. Each ASR shall include, at a minimum: (1) a summary of all Quarterly Compliance Reports for that year identified in

Incidental Take Permit
No. 2081-2020-037-06
(Amendment No. 2)
BALDY MESA SOLAR, LLC
BALDY MESA SOLAR PROJECT

Condition of Approval 6.7; (2) a general description of the status of the Project Area and Covered Activities, including actual or projected completion dates, if known; (3) a copy of the table in the MMRP with notes showing the current implementation status of each mitigation measure; (4) an assessment of the effectiveness of each completed or partially completed mitigation measure in avoiding, minimizing and mitigating Project impacts; (5) all available information about Project-related incidental take of the Covered Species; and (6) information about other Project impacts on the Covered Species.

6.9. CNDDDB Observations. The Designated Representative shall submit all observations of Covered Species to CDFW's California Natural Diversity Database (CNDDDB) within 60 calendar days of the observation and the Designated Representative shall include copies of the submitted forms with the next Quarterly Compliance Report or ASR, whichever is submitted first relative to the observation. More information is available at <https://www.wildlife.ca.gov/Data/CNDDDB>.

6.10. Final Mitigation Report. No later than 45 days after completion of all mitigation measures, Permittee shall provide CDFW with a Final Mitigation Report. The Biological Monitor(s) or Authorized Biologist(s) shall prepare the Final Mitigation Report which shall include, at a minimum: (1) a summary of all Quarterly Compliance Reports and all ASRs; (2) a copy of the table in the MMRP with notes showing when each of the mitigation measures was implemented; (3) all available information about Project-related incidental take of the Covered Species; (4) information about other Project impacts on the Covered Species; (5) beginning and ending dates of Covered Activities; (6) an assessment of the effectiveness of this ITP's Conditions of Approval in minimizing and fully mitigating Project impacts of the taking on Covered Species; (7) recommendations on how mitigation measures might be changed to more effectively minimize take and mitigate the impacts of future projects on the Covered Species; (8) Include geographic information system (GIS) shapefiles in the format specified in Attachment 3; and (9) any other pertinent information.

7. Take Minimization Measures: The following requirements are intended to ensure the minimization of incidental take of Covered Species in the Project Area during Covered Activities. Permittee shall implement and adhere to the following conditions to minimize take of Covered Species:

Desert Tortoise and Mohave Ground Squirrel

7.1. Herbicides. Permittee shall only use herbicides containing a harmless dye and registered with the California Department of Pesticide Regulation (DPR). All herbicides shall be applied in accordance with regulations set by DPR. All herbicides shall be used according to labeled

Incidental Take Permit
No. 2081-2020-037-06
(Amendment No. 2)
BALDY MESA SOLAR, LLC
BALDY MESA SOLAR PROJECT

instructions. Labeled instructions for the herbicide used shall be made available to CDFW upon request. No herbicide application when winds are greater than five (5) miles per hour.

- 7.2. Rodenticides and Insecticides.** Permittee shall not use rodenticides and/or insecticides on the Project Area without prior written permission from CDFW. Permittee shall not use any second-generation anticoagulant rodenticide (brodifacoum, bromadiolone, difethialone, and difenacoum) on the Project Area. Permittee shall not use any first-generation anticoagulant rodenticide (diphacinone, chlorophacinone, and warfarin) on the Project Area without prior written permission from CDFW.
- 7.3. Removal of Debris.** Permittee shall remove all hardened concrete and other loose debris in areas that need to be cleared by slowly removing stored material starting from the top and working down to ground level, rather than scooping from the ground up. This method will minimize the possibility of harming a Covered Species using the debris as shelter and will allow them to escape.
- 7.4. Entrapment Inspections.** Any pipes, culverts, or similar structures with a diameter greater than 3 inches and less than 8 inches aboveground shall be inspected by the Authorized Biologist(s) and/or Biological Monitor(s) for Covered Species' before the material is moved, buried, or capped. The Authorized Biologist(s) and/or Biological Monitor(s) shall inspect all open holes and trenches within Covered Species habitat at a minimum of twice a day and just prior to backfilling. At the end of each work day, Permittee shall place an escape ramp at each end of trenches to allow any animals that may have become trapped in the trench to climb out overnight. The ramp may be constructed of either dirt fill or wood planking or other suitable material that is placed at an angle no greater than 30 degrees. If any worker discovers that Covered Species have become trapped, they shall halt Covered Activities and notify the Biological Monitor(s) and/or Authorized Biologist(s) immediately. Project workers and the Biological Monitor(s) and/or Authorized Biologist(s) shall allow the Covered Species to escape unimpeded if possible, or an Authorized Biologist(s) approved under Condition of Approval 5.4 of this ITP shall move the Covered Species out of harm's way before allowing work to continue.
- 7.5. Pre-Construction Clearance Surveys for Desert Tortoise.** No later than 30 days prior to start of Covered Activities, the Authorized Biologist(s) and/or Biological Monitor(s) approved under this ITP shall conduct pre-construction clearance surveys for Covered Species, using the methods described in the most recent United States Fish and Wildlife Service (USFWS) Desert Tortoise (Mojave Population) Field Manual (hereinafter referred to as USFWS Field Manual). In addition to the guidance provided in the USFWS Field Manual, CDFW provides the following requirement(s):

Incidental Take Permit
 No. 2081-2020-037-06
 (Amendment No. 2)
BALDY MESA SOLAR, LLC
BALDY MESA SOLAR PROJECT

- 7.5.1. Pre-construction clearance surveys shall be completed using perpendicular survey routes within the Project Area. Pre-construction clearance surveys cannot be combined with other clearance surveys conducted for other species while using the same personnel. Covered Activities cannot start until two (2) negative results from consecutive surveys using perpendicular survey routes for the Covered Species are documented.
- 7.5.2. These surveys shall cover 100 percent of the Project Area and a 50-foot buffer zone around the Project site. The Biological Monitor(s) and/or Authorized Biologist(s) shall record all potential Covered Species and burrows within the pre-construction clearance survey area, using global positioning system (GPS) technology. The Biological Monitor(s) and/or Authorized Biologist(s) shall provide the results of the pre-construction clearance survey (including all information of the USFWS Protocol data sheet) to CDFW within 10 Calendar days of completing the surveys. The use of specialized equipment (e.g., fiber optics) may be necessary to thoroughly inspect all burrows in preparation for collapsing them.
- 7.5.3. Twenty-Four (24) hours prior to the start of any Covered Activities, except for areas already cleared within installation of desert tortoise exclusion fencing, the Biological Monitor(s) and/or Authorized Biologist(s) shall conduct a final clearance survey of Project Area. The use of specialized equipment (e.g., fiber optics) may be necessary to thoroughly inspect all burrows in preparation for collapsing them.
- 7.6. Pre-Construction Surveys for Mohave Ground Squirrels. No more than 30 calendar days prior to the start of ground disturbing activities the Authorized Biologist(s)/Biological Monitor(s) shall be present onsite to perform a pre-construction survey for MGS. These surveys shall cover the Project Area and a 50-foot buffer zone. All known or suspected MGS burrows within the work areas shall be flagged to alert biological and work crews to their presence. A report documenting the results of the pre-construction surveys shall be submitted to CDFW within 30 calendar days after performing them.
- 7.7. Covered Species Observations. If a Covered Species is observed during Covered Activities, all work within 300 feet of the Covered Species shall immediately stop and the observation shall be immediately reported to the Authorized Biologist(s). Covered Activities shall not resume until the Authorized Biologist(s) and/or Biological Monitor(s) has verified the Covered Species has left the Project Area OR an Authorized Biologist(s) approved under Condition of Approval 5.4 of this ITP relocates the Covered Species as described in this ITP and Desert Tortoise Translocation Plan. The Designated Representative shall notify CDFW of any Covered Species observations within the Project Area. Notification shall occur as described in Condition of Approval 6.5 within 24 hours. Notification and the written report shall include the date, location, and circumstances of the observation, the name of the

Incidental Take Permit
 No. 2081-2020-037-06
 (Amendment No. 2)
BALDY MESA SOLAR, LLC
BALDY MESA SOLAR PROJECT

Authorized Biologist(s) that relocated the individual, pictures, map and shapefiles with the location (including GPS coordinates) where the individual was moved as specified in the DTTP.

- 7.8. Desert Tortoise Burrow Excavation.** Only Authorized Biologist(s) and Biological Monitor(s) approved by CDFW are authorized to conduct burrow excavation. Excavation of burrows shall follow the methods described the USFWS Field Manual.
- 7.9. Mohave Ground Squirrel Burrow Excavation.** The Authorized Biologist(s) shall fully excavate by hand all burrows OR scope each burrow within the Project Area that are suspected or known to be occupied by Mohave ground squirrels. The Authorized Biologist(s) shall allow Mohave ground squirrels encountered in the excavated burrows during their active period (March 15 – July 15) to escape out of harm’s way. During the Mohave ground squirrel dormant period (September 1 – January 31), the Authorized Biologist(s) shall collect and immediately relocate the individuals to an artificial burrow in the following preferential order: 1.) relocate to the nearest public lands with suitable habitat from where the squirrel was originally captured; 2.) relocate outside of right-of-way, within existing parcel on private property. Mohave ground squirrels may not be relocated to private property unless the Permittee obtains written permission from the property owner prior to Covered Activities. The Mohave ground squirrel may only be relocated by the Authorized Biologist(s). The Authorized Biologist(s) shall prepare relocation burrows in the following manner: (1) A hole of at least two feet deep shall be dug; (2) Install a nine-inch diameter non-collapsible plastic container, which shall be connected to a three-inch diameter non-collapsible plastic pipe that runs to the ground surface at a 45-degree angle; (3) The Authorized Biologist(s) shall place the Mohave ground squirrel in the artificial burrow and lightly plug the burrow mouth with soil in a manner that is similar to a natural Mohave ground squirrel burrow.
- 7.10. Desert Tortoise Translocation out of Harm’s Way.** Regardless of the number of Covered Species estimated to be moved out of harm’s way the Permittee shall prepare a modified Desert Tortoise Translocation Plan (DTTP) to address only moving desert tortoise out of harm’s way 15 Calendar days prior to start of Covered Activities and submit it according to condition of approval 6.5 of this ITP. Covered Activities are not authorized to start until the DTTP is approved in writing by CDFW. The DTTP shall follow the most current guidelines provided by USFWS and CDFW regarding Covered Species translocation. Where guidance differs between USFWS and CDFW, verbal and/or written direction provided by CDFW always controls.

The list of items below are the most common examples of the differences between CDFW and USFWS guidelines. These shall be included in the DTTP along with the most recent USFWS translocation guidelines:

Incidental Take Permit
No. 2081-2020-037-06
(Amendment No. 2)
BALDY MESA SOLAR, LLC
BALDY MESA SOLAR PROJECT

- Translocated tortoise are tortoises removed from the Project Area and/or have a radio transmitter attached.
- The Authorized Biologist shall determine when the creation of artificial burrows is needed.
- Moving out of harm's way will consist of hand-carrying the desert tortoise as close to ground level as possible to the release site. Each tortoise that is hand-carried will be kept upright in its normal spatial orientation and the handler, wearing disposable examination gloves (one pair per tortoise), will move the tortoise as quickly and smoothly as possible.
- Ambient air temperature guidelines shall be followed as specified in Condition of Approval 7.11 of this ITP.
- Tortoises <100 millimeters (mm) midline carapace length (MCL) shall be released immediately without being held, transmittered, or blood drawn for disease testing as long as the temperature requirements in Condition of Approval 8.10 of this ITP above are met.
- Linear Facilities: Tortoises >100 mm MCL that are moved due to their burrow being collapsed shall be transmittered (duration of monitoring shall be determined on an individual project basis and shall be included in the DTTP) and disease tested.
- The Applicant will identify, in advance, suitable release areas within the action area, but no more than 300 meters away (generally within existing home range), to move desert tortoises from harm's way. Release areas would be surveyed to identify suitable habitat, shelter sites, resident tortoises already established in the area, and active burrows. The number of release area will be determined by the survey results and the number of desert tortoises anticipated to be moved.
- All tortoise burrows within the Project Area shall be excavated following procedures outlined in the U. S. Fish and Wildlife Service Desert Tortoise Field Manual.
- Creation of artificial burrows, as well as translocation of tortoises and eggs shall only occur on land(s) (including Bureau of Land Management), when written authorization has been obtained from the landowner prior to the start of Covered Activities. The written permission from the landowner shall be included in the DTTP and the DTTP shall not be approved by CDFW until authorization is provide in writing. If creation of artificial burrows or translocation of tortoise or eggs is

Incidental Take Permit
No. 2081-2020-037-06
(Amendment No. 2)
BALDY MESA SOLAR, LLC
BALDY MESA SOLAR PROJECT

proposed to take place on private lands then in addition to written approval required above, some form of protection for the land such as a conservation easement shall be in place prior to translocation occurring.

- Cleaning and Disinfection Protocol. Trifectant and Rescue Ready to Use One Step Disinfectant Cleaner are the only products authorized under this ITP and its associated DTTP to be used as a disinfectant. These products are not authorized to be applied using a spray bottle or other spray methods.

Cleaning and Disinfection Protocol shall include the following:⁴

- Remove all grossly visible debris.
- Wash the area or item with water and mild detergent.
- Thoroughly rinse the cleaned area to remove any detergent residue.
- Allow the area to dry completely
- Apply disinfectant mixture.
- Allow the full disinfectant product recommended contact time.
- Thoroughly rinse away any residual disinfectant and allow the area or item to air dry.

7.11. Ambient Air Temperature for Desert Tortoise: During all handling procedures, Covered Species shall be treated in a manner to ensure that they do not overheat or exhibit signs of overheating (e.g., gaping, foaming at the mouth, etc.), or are placed in a situation where they cannot maintain surface and core temperatures necessary to their well-being. Covered Species shall be kept shaded at all times until it is safe to release them. For the purposes of this permit, ambient air temperature shall be measured in the shade, protected from wind, at a height of 5 centimeters above the ground surface. For all Covered Activities no Covered Species shall be captured, moved, transported, released, or purposefully caused to leave its burrow for whatever reason when the ambient air temperature is above 95° Fahrenheit (F) (35° Celsius (C)). No Covered Species shall be captured if the ambient air temperature is anticipated to exceed 95° F (35° C) before handling or processing can be completed. If the ambient air temperature exceeds 95° F (35° C) during handling or processing, Covered Species shall be kept shaded in an environment that does not exceed 95° F (35° C), and not released until ambient air temperature declines to below 95°F (35°C). Covered Species moved during the less active season (June 1 to August 31 and November 1 to March 31) shall be monitored by the Authorized Biologist(s) for at least two days after placement in the new burrows to ensure their safety. During relocation, the Authorized Biologist(s) may hold a captured Covered Species overnight and move them the following morning within these temperature constraints.

⁴ Brown, Mary. Cleaning and Disinfection Protocol. Department of Infectious Diseases and Pathology, College of Veterinary Medicine, Gainesville FL.

- 7.12. Desert Tortoise Species Rehydration.** If a Covered Species voids its bladder as a result of being handled, the Authorized Biologist(s) shall rehydrate the animal(s). The Authorized Biologist(s) shall rehydrate the Covered Species at the location where the animal(s) was or were captured, or the location where the animal(s) is or will be released. The Authorized Biologist(s) shall rehydrate the Covered Species by placing it in a tub with a clean plastic disposable liner. The Authorized Biologist(s) shall add water to the lined tub while ensuring that the water level is not higher than the lower jaw of the Covered Species. The Authorized Biologist(s) shall rehydrate each Covered Species individually for a minimum of 10 to 20 minutes. The Authorized Biologist(s) shall place the lined tub in a quiet protected area during rehydration.
- 7.13. Covered Species Handling Records.** The Authorized Biologist(s) and/or Biological Monitor(s) shall maintain a record of all Covered Species handled. This information shall include: (a) the locations (narrative and maps) and dates of observation, including whether the individual(s) was found above ground or in a burrow; (b) ambient temperature when handled and released; (c) general condition and health of the individual(s), including injuries, state of healing, and whether the individual(s) voided its bladders; (d) identified diagnostic markings (i.e., identification numbers or marked marginal scutes); (e) location moved from and location moved to (using GPS technology), including information on any burrow (natural or artificial) utilized; (f) whether any eggs were discovered and relocated; (g) digital photographs of any Covered Species and eggs handled; and (h) results of ongoing monitoring. The Designated Representative(s) shall provide CDFW with the information listed above submitted in the quarterly reports.
- 7.14. Covered Species Guards.** The design of Covered Species guards shall include exit ramps and cleanout. Guards shall be installed along the Existing Right-of-Way fence. Guard locations and design shall be provided to CDFW and shall be approved by CDFW in writing prior to starting Covered Activities.
- 7.15. Temporary Desert Tortoise Fencing.** Temporary desert tortoise fencing shall be installed around the array fields, operation and maintenance facilities, warehouses, substations, switchyard, and interconnection facilities during construction. Construct the desert tortoise fence according to Chapter 8 of the USFWS Field Manual, but if any tortoises <100 mm MCL are translocated within 500 meters of the Project site, tortoise fencing shall be 16 gauge or heavier galvanized after welded wire with mesh opening of ½ inch horizontal by ½ inch vertical (Attachment 4).
- 7.16. Covered Species Fence Maintenance Inspection.** The Biological Monitor(s) and/or Authorized Biologist(s) shall inspect the Covered Species fencing during the Covered

Activities, at the end of each workday, and during major rainfall events and within 24 hours to ensure Covered Species is prohibited from entering the Project Area. If the fence is compromised, repairs shall be completed immediately, and clearance protocol level surveys shall be conducted as described in Condition of Approval 7.5.

- 7.17. Vehicle Inspection.** Workers shall inspect for Covered Species under vehicles and equipment before the vehicles and equipment are moved. If a Covered Species is present, the worker shall contact the Biological Monitor(s) or Authorized Biologist(s) and wait for the Covered Species to move unimpeded to a safe location or the Authorized Biologist(s) shall relocate the Covered Species as described in Condition of Approval 7.10 before moving vehicles and equipment.
- 7.18. Staging Area and Parking Area.** The Permittee shall enclose all staging areas and parking areas with Covered Species exclusion fencing. All parked vehicles and equipment shall be inspected prior to being moved. If a Covered Species is found within a staging or parking area the worker shall immediately contact a Biological Monitor(s) and/or Authorized Biologist(s) approved in Condition of Approval 5 of this ITP. A biologist approved in Condition of Approval 5 of this ITP shall relocate the Covered Species in accordance with Condition of Approval 7.10 of this ITP and the DTTP.
- 7.19. Raven Management.** The Permittee shall prepare a Raven Management Plan to minimize the potential to attract common ravens to the site and submit it to CDFW for review and approval. In addition, the Permittee shall provide funds to the Renewable Energy Action Team (REAT) account established with the National Fish and Wildlife Foundation (NFWF) to contribute to a region-wide raven control plan to help address raven predation on the tortoise. This contribution shall be used to address raven predation on a regional basis and shall be calculated as a one-time payment of \$105 per acre of project disturbance. Based on this calculation the Permittee shall provide a one-time payment at \$105.00/acre for 1,150 acres at **\$120,750.00** to the REAT account established with NFWF's Raven Management Plan fund. A minimum of 15 days prior to the start of Covered Activities these funds shall be provided to NFWF using appropriate deposit document (Attachment 5) and proof of paying this fee shall be provided to CDFW within 24 hours after the funds have been provided to NFWF.
- 7.20. Erosion Control Materials – Monofilament Netting.** To minimize the risk of ensnaring and strangling Covered Species, Permittee shall not utilize erosion control materials containing synthetic (e.g., plastic or nylon) monofilament netting. Geotextiles, fiber rolls, and other erosion control measures shall be made of loose-weave mesh, such as jute, coconut (coir) fiber, or other products without welded weaves. Permittee shall utilize erosion control materials composed entirely of natural-fiber biodegradable materials. Permittee shall not use plastic “photodegradable” erosion control materials.

Incidental Take Permit
 No. 2081-2020-037-06
 (Amendment No. 2)
BALDY MESA SOLAR, LLC
BALDY MESA SOLAR PROJECT

- 7.21. Invasive Plant Management Plan.** Permittee shall develop an Invasive Plant Management Plan focused on controlling or eradicating existing invasive plants within the project site and preventing the introduction of new nonnative and invasive plants into the project site. The Plan shall include a list of plant species targeted for control or eradication, a description of the methods that will be used for control or eradication, a list of BMPs to prevent the introduction and spread of invasive plant species into and out of the project site, monitoring requirement, success criteria, and a rapid response plan in the event that a new plant species invades the project site. The Plan shall be implemented during Covered Activities and monitored for the time specified in the Plan. The Plan shall be submitted to CDFW for review and approval no later than 60 days prior to the commencement of Covered Activities.
- 7.22. Full time monitoring.** An Authorized Biologist(s) or Biological Monitor(s) shall be present during all Covered Activities that occur outside a permanent fenced area.
- 7.23. Revegetation.** Plantings and seed mix shall be approved by CDFW prior to application. Plantings and seed mix shall be comprised of only native plant material from the same geographic range as the Project.

Operation and Maintenance Minimization Measures

- 7.24. Modified Fencing for Solar Sites.** Approximately 3 years post construction and once vegetation has been allowed to recover to a minimum 50% from baseline site conditions within the solar sites the temporary desert tortoise fencing will be removed. The chain link security fence will be bent upward 6 to 8 inches above the ground and bent upward so that no sharp edges are exposed along the lower fence margin. The fence will remain open during O&M for the duration of the permit. Provide photos of the modified fence design and the 6–8-inch gap described above in your annual report.
- 7.25. Burrow Avoidance within Modified Fenced Solar Sites.** If a potential Covered Species burrow (one that shows evidence of current use or was used in the past) is discovered or a Covered Species is found in an "atypical" den (e.g., a pipe or culvert) during the non-active season, a 100-foot buffer shall be established using flagging. If an occupied burrow is discovered during the desert tortoise active season (September-October and April-May), a buffer of at least 250 feet shall be established. Burrows shall be avoided. Buffer zones shall have restricted entry for activities approved by CDFW.
- 7.26. Covered Species Inspection within Modified Fenced Solar Sites.** Workers shall inspect for Covered Species under vehicles and equipment every time the vehicles and equipment are moved. If a Covered Species is present, the worker shall wait for the Covered Species to move on its own to a safe location. Alternatively, the Designated Representative,

Incidental Take Permit
No. 2081-2020-037-06
(Amendment No. 2)
BALDY MESA SOLAR, LLC
BALDY MESA SOLAR PROJECT

Authorized Biologist, or Biological Monitor shall be contacted to determine if the animal may be safely moved within the conditions of the ITP.

- 7.27. Covered Species Observations within Modified Fenced Solar Sites.** During Project implementation, all workers shall inform the Designated Representative if a Covered Species is seen within the Project Site. All work in the vicinity of the Covered Species, which could injure or kill the animal, shall cease until the Covered Species is moved by the approved Authorized Biologist or it moves from the construction area of its own accord.
- 7.28. Clearance surveys within Modified Fenced Solar Sites.** Twenty-Four (24) hours prior to the start of Covered Activities the AB or BM shall conduct a survey of the area where maintenance work will occur. If a desert tortoise burrow is found in the work area the Permittee shall follow guidance in 7.25.
- 7.29. Annual Status Report during O&M.** Permittee shall provide CDFW with an Annual Status Report (ASR) no later than January 31 of every year beginning with issuance of this ITP and continuing until permit termination date or CDFW determines they are no longer necessary. Each ASR shall include, at a minimum: (1) a summary of any siting's of covered species within the site (2) results of biological surveys performed during the year (3) status of any covered species living on site (4) all available information about Project-related incidental take of the Covered Species; and (5) information about other Project impacts on the Covered Species

8. Habitat Management Land Acquisition: CDFW has determined that permanent protection and perpetual management of compensatory habitat is necessary and required pursuant to CESA to fully mitigate Project-related impacts of the taking on the Covered Species that will result from implementation of the Covered Activities. This determination is based on factors including an assessment of the importance of the habitat in the Project Area, the extent to which the Covered Activities will impact the habitat, and CDFW's estimate of the protected acreage required to provide for adequate compensation.

To meet this requirement, the Permittee shall either purchase **612 acres** of Covered Species Mojave Ground Squirrel credits, **612 acres** of Covered Species Desert Tortoise credits, and **1,038 acres** of Covered Species Western Joshua Tree credits from a CDFW-approved mitigation or conservation bank pursuant to Condition of Approval 9.2 below OR shall provide for both the permanent protection and management of 612 acres of Covered Species Mojave Ground Squirrel, 612 acres of Covered Species Desert Tortoise, and 1,038 acres of Covered Species Western Joshua Tree Habitat Management (HM) lands pursuant to Condition of Approval 8.3 below and the calculation and deposit of the management funds pursuant to Condition of Approval 9.4 below. Purchase of Covered Species credits OR permanent protection and funding for perpetual management of HM lands must be complete before starting Covered Activities, or within **36**

Incidental Take Permit
 No. 2081-2020-037-06
 (Amendment No. 2)
BALDY MESA SOLAR, LLC
BALDY MESA SOLAR PROJECT

months of the effective date of this ITP if Security is provided pursuant to Condition of Approval 9 below for all uncompleted obligations.

8.1. Cost Estimates. For the purposes of determining the Security amount, CDFW has estimated the cost sufficient for CDFW or its contractors to complete acquisition, protection, and perpetual management of the HM lands as follows:

- 8.1.1. Land acquisition costs for HM lands identified in Condition of Approval 9.3 below, estimated at \$2,500.00/acre for 1,038 acres: **\$2,595,000.00**. Land acquisitions costs are estimated using local fair market current value per acre for lands with habitat values meeting mitigation requirements;
- 8.1.2. All other costs necessary to review and acquire the land in fee title and record a conservation easement as described in Condition of Approval 9.3.1 and 9.3.2 below: **\$17,440.00**.
- 8.1.3. Start-up costs for HM lands, including initial site protection and enhancement costs as described in Condition of Approval 9.3.6 below, estimated at \$2,000.00/acre for 1,038 acres: **\$2,076,000.00**; including.
- 8.1.4. Interim management period funding as described in Condition of Approval 9.3.7 below, estimated at \$600.00/acre for 1,038 acres: **\$622,800.00**.
- 8.1.5. Long-term management funding as described in Condition of Approval 9.4 below, estimated at \$3,100.00/acre for 1038 acres: **\$3,217,800.00**. Long-term management funding is estimated initially for the purpose of providing Security to ensure implementation of HM lands management.
- 8.1.6. Related transaction fees including but not limited to account set-up fees, administrative fees, title and documentation review and related title transactions, expenses incurred from other state agency reviews, and overhead related to transfer of HM lands to CDFW as described in Condition of Approval 9.5, estimated at **\$6,000.00**.
- 8.1.7. All costs associated with CDFW engaging an outside contractor to complete the mitigation tasks, including but not limited to acquisition, protection, and perpetual funding and management of the HM lands and restoration of temporarily disturbed habitat. These costs include but are not limited to the cost of issuing a request for proposals, transaction costs, contract administration costs, and costs associated with monitoring the contractor's work **\$75,000.00**.

Incidental Take Permit
No. 2081-2020-037-06
(Amendment No. 2)
BALDY MESA SOLAR, LLC
BALDY MESA SOLAR PROJECT

8.2. Covered Species Credits. If the Permittee elects to purchase Covered Species credits to complete compensatory mitigation obligations, then Permittee shall purchase 612 acres of Covered Species Mojave Ground Squirrel credits, 612 acres of Covered Species Desert Tortoise credits, and 1,038 acres of Covered Species Western Joshua Tree credits from a CDFW-approved mitigation or conservation bank prior to initiating Covered Activities, or no later than 36 months from the issuance of this ITP if Security is provided pursuant to Condition of Approval 9 below. Prior to purchase of Covered Species credits, Permittee shall obtain CDFW approval to ensure the mitigation or conservation bank is appropriate to compensate for the impacts of the Project. Permittee shall submit to CDFW a copy of the Bill of Sale(s) and Payment Receipt prior to initiating Covered Activities or within 36 months from issuance of this ITP if Security is provided.

8.3. Habitat Management Lands Acquisition and Protection. If the Permittee elects to provide for the acquisition, permanent protection, and perpetual management of HM lands to complete compensatory mitigation obligations, then the Permittee shall:

8.3.1. **Fee Title.** Transfer fee title of the HM lands to CDFW pursuant to terms approved in writing by CDFW. Alternatively, CDFW, in its sole discretion, may authorize a governmental entity, special district, non-profit organization, for-profit entity, person, or another entity to hold title to and manage the property provided that the district, organization, entity, or person meets the requirements of Government Code sections 65965-65968, as amended.

8.3.2. **Conservation Easement.** If CDFW does not hold fee title to the HM lands, CDFW shall act as grantee for a conservation easement over the HM lands or shall, in its sole discretion, approve a non-profit entity, public agency, or Native American tribe to act as grantee for a conservation easement over the HM lands provided that the entity, agency, or tribe meets the requirements of Civil Code section 815.3. If CDFW elects not to be named as the grantee for the conservation easement, CDFW shall be expressly named in the conservation easement as a third-party beneficiary. The Permittee shall obtain CDFW written approval of any conservation easement before its execution or recordation. No conservation easement shall be approved by CDFW unless it complies with Civil Code sections 815-816, as amended, and Government Code sections 65965-65968, as amended and includes provisions expressly addressing Government Code sections 65966(j) and 65967(e). Because the “doctrine of merger” could invalidate the conservation interest, under no circumstances can the fee title owner of the HM lands serve as grantee for the conservation easement.

8.3.3. **HM Lands Approval.** Obtain CDFW written approval of the HM lands before acquisition and/or transfer of the land by submitting, at least three months before acquisition and/or transfer of the HM lands, documentation identifying the land to be purchased

or property interest conveyed to an approved entity as mitigation for the Project's impacts on Covered Species;

- 8.3.4. HM Lands Documentation. Provide a recent preliminary title report, Phase I Environmental Site Assessment, and other necessary documents (please contact CDFW for document list). All documents conveying the HM lands and all conditions of title are subject to the approval of CDFW, and if applicable, the Wildlife Conservation Board and the Department of General Services;
- 8.3.5. Land Manager. Designate both an interim and long-term land manager approved by CDFW. The interim and long-term land managers may, but need not, be the same. The interim and/or long-term land managers may be the landowner or another party. Documents related to land management shall identify both the interim and long-term land managers. Permittee shall notify CDFW of any subsequent changes in the land manager within 30 days of the change. If CDFW will hold fee title to the mitigation land, CDFW will also act as both the interim and long-term land manager unless otherwise specified. The grantee for the conservation easement cannot serve as the interim or long-term manager without the express written authorization of CDFW in its sole discretion.
- 8.3.6. Start-up Activities. Provide for the implementation of start-up activities, including the initial site protection and enhancement of HM lands, once the HM lands have been approved by CDFW. Start-up activities include, at a minimum: (1) preparing a final management plan for CDFW approval (see <https://nrm.dfg.ca.gov/FileHandler.ashx?DocumentID=137386&inline>) (2) conducting a baseline biological assessment and land survey report within four months of recording or transfer; (3) developing and transferring Geographic Information Systems (GIS) data if applicable; (4) establishing initial fencing; (5) conducting litter removal; (6) conducting initial habitat restoration or enhancement, if applicable; and (7) installing signage;
- 8.3.7. Interim Management (Initial and Capital). Provide for the interim management of the HM lands. The Permittee shall ensure that the interim land manager implements the interim management of the HM lands as described in the final management plan and conservation easement approved by CDFW. The interim management period shall be a minimum of three years from the date of HM land acquisition and protection and full funding of the Endowment and includes expected management following start-up activities. Interim management period activities described in the final management plan shall include fence repair, continuing trash removal, site monitoring, and vegetation and invasive species management

Incidental Take Permit
No. 2081-2020-037-06
(Amendment No. 2)
BALDY MESA SOLAR, LLC
BALDY MESA SOLAR PROJECT

Permittee shall either (1) provide Security to CDFW for the minimum of three years of interim management that the land owner, Permittee, or land manager agrees to manage and pay for at their own expense, (2) establish an escrow account with written instructions approved in advance in writing by CDFW to pay the land manager annually in advance, or (3) establish a short-term enhancement account with CDFW or a CDFW-approved entity for payment to the land manager.

8.4. Endowment Fund. If the Permittee elects to provide for the acquisition, permanent protection, and perpetual management of HM lands to complete compensatory mitigation obligations, then Permittee shall ensure that the HM lands are perpetually managed, maintained, and monitored by the long-term land manager as described in this ITP, the conservation easement, and the final management plan approved by CDFW. After obtaining CDFW approval of the HM lands, Permittee shall provide long-term management funding for the perpetual management of the HM lands by establishing a long-term management fund (Endowment). The Endowment is a sum of money, held in a CDFW-approved fund that is permanently restricted to paying the costs of long-term management and stewardship of the mitigation property for which the funds were set aside, which costs include the perpetual management, maintenance, monitoring, and other activities on the HM lands consistent with this ITP, the conservation easement, and the management plan required by Condition of Approval 8.3. Endowment as used in this ITP shall refer to the endowment deposit and all interest, dividends, other earnings, additions and appreciation thereon. The Endowment shall be governed by this ITP, Government Code sections 65965-65968, as amended, and Probate Code sections 18501-18510, as amended.

After the interim management period, Permittee shall ensure that the designated long-term land manager implements the management and monitoring of the HM lands according to the final management plan. The long-term land manager shall be obligated to manage and monitor the HM lands in perpetuity to preserve their conservation values in accordance with this ITP, the conservation easement, and the final management plan. Such activities shall be funded through the Endowment.

8.4.1. Identify an Endowment Manager. The Endowment shall be held by the Endowment Manager, which shall be either CDFW or another entity qualified pursuant to Government Code sections 65965-65968, as amended.

Permittee shall submit to CDFW a written proposal that includes: (i) the name of the proposed Endowment Manager; (ii) whether the proposed Endowment Manager is a governmental entity, special district, nonprofit organization, community foundation, or congressionally chartered foundation; (iii) whether the proposed Endowment Manager holds the property or an interest in the property for conservation purposes as required by Government Code section 65968(b)(1) or, in the alternative, the basis for finding

that the Project qualifies for an exception pursuant to Government Code section 65968(b)(2); and (iv) a copy of the proposed Endowment Manager’s certification pursuant to Government Code section 65968(e).

Within thirty days of CDFW’s receipt of Permittee’s written proposal, CDFW shall inform Permittee in writing if it determines the proposal does not satisfy the requirements of Fish and Game Code section 2081(b)(3) and, if so, shall provide Permittee with a written explanation of the reasons for its determination. If CDFW does not provide Permittee with a written determination within the thirty-day period, the proposal shall be deemed consistent with Section 2081(b)(3).

8.4.2. Calculate the Endowment Funds Deposit. After obtaining CDFW written approval of the HM lands, long-term management plan, and Endowment Manager, Permittee shall prepare an endowment assessment (equivalent to a Property Analysis Record (PAR)) to calculate the amount of funding necessary to ensure the long-term management of the HM lands (Endowment Deposit Amount). Note that the endowment for the easement holder should not be included in this calculation. The Permittee shall submit to CDFW for review and approval the results of the endowment assessment before transferring funds to the Endowment Manager.

8.4.2.1. Capitalization Rate and Fees. Permittee shall obtain the capitalization rate from the selected Endowment Manager for use in calculating the endowment assessment and adjust for any additional administrative, periodic, or annual fees.

8.4.2.2. Endowment Buffers/Assumptions. Permittee shall include in the endowment assessment assumptions the following buffers for endowment establishment and use that will substantially ensure long-term viability and security of the Endowment:

8.4.2.2.1. 10 Percent Contingency. A 10 percent contingency shall be added to each endowment calculation to hedge against underestimation of the fund, unanticipated expenditures, inflation, or catastrophic events.

8.4.2.2.2. Three Years Delayed Spending. The endowment shall be established assuming spending will not occur for the first three years after full funding.

8.4.2.2.3. Non-annualized Expenses. For all large capital expenses to occur periodically but not annually such as fence replacement or well replacement, payments shall be withheld from the annual disbursement until the year of anticipated need or upon request to Endowment Manager and CDFW.

8.4.3. Transfer Long-term Endowment Funds. Permittee shall transfer the long-term endowment funds to the Endowment Manager upon CDFW approval of the Endowment Deposit Amount identified above.

8.4.4. Management of the Endowment. The approved Endowment Manager may pool the Endowment with other endowments for the operation, management, and protection of HM lands for local populations of the Covered Species but shall maintain separate accounting for each Endowment. The Endowment Manager shall, at all times, hold and manage the Endowment in compliance with this ITP, Government Code sections 65965-65968, as amended, and Probate Code sections 18501-18510, as amended.

Notwithstanding Probate Code sections 18501-18510, the Endowment Manager shall not make any disbursement from the Endowment that will result in expenditure of any portion of the principal of the endowment without the prior written approval of CDFW in its sole discretion. Permittee shall ensure that this requirement is included in any agreement of any kind governing the holding, investment, management, and/or disbursement of the Endowment funds.

Notwithstanding Probate Code sections 18501-18510, if CDFW determines in its sole discretion that an expenditure needs to be made from the Endowment to preserve the conservation values of the HM lands, the Endowment Manager shall process that expenditure in accordance with directions from CDFW. The Endowment Manager shall not be liable for any shortfall in the Endowment resulting from CDFW's decision to make such an expenditure.

8.5. Reimburse CDFW. Permittee shall reimburse CDFW for all reasonable costs incurred by CDFW related to issuance and monitoring of this ITP, including, but not limited to transaction fees, account set-up fees, administrative fees, title and documentation review and related title transactions, costs incurred from other state agency reviews, and overhead related to transfer of HM lands to CDFW.

9. **Security:** The Permittee may proceed with Covered Activities only after the Permittee has ensured funding (Security) to complete any activity required by Condition of Approval 8 that has not been completed before Covered Activities begin. Permittee shall provide Security as follows:

9.1. Security Amount. The Security shall be in the amount of **\$8,610,040.00** or in the amount identified in 8.1 specific to the obligation that has not been completed. This amount is determined by CDFW based on the cost estimates identified in Condition of Approval 8.1 above, sufficient for CDFW or its contractors to complete land acquisition, property enhancement, startup costs, initial management, long-term management, and monitoring.

9.2. Security Form. The Security shall be in the form of an irrevocable letter of credit (see

Incidental Take Permit
No. 2081-2020-037-06
(Amendment No. 2)
BALDY MESA SOLAR, LLC
BALDY MESA SOLAR PROJECT

Attachment 6), or another form of Security approved in advance in writing by CDFW's Office of the General Counsel.

- 9.3. Security Timeline. The Security shall be provided to CDFW before Covered Activities begin.
- 9.4. Security Holder. The Security shall be held by CDFW or in a manner approved in advance in writing by CDFW.
- 9.5. Security Transmittal. Permittee shall transmit it to CDFW with a completed Mitigation Payment Transmittal Form (see Attachment 7) or by way of an approved instrument such as an escrow agreement, irrevocable letter of credit, or other.
- 9.6. Security Drawing. The Security shall allow CDFW to draw on the principal sum if CDFW, in its sole discretion, determines that the Permittee has failed to comply with the Conditions of Approval of this ITP.
- 9.7. Security Release. The Security (or any portion of the Security then remaining) shall be released to the Permittee after CDFW has conducted an on-site inspection and received confirmation that all secured requirements have been satisfied, as evidenced by:

Credit Purchase

- Copy of Bill of Sale(s) and Payment Receipt(s) or Credit Transfer Agreement for the purchase of Covered Species credits; and
- Timely submission of all required reports.

Habitat Management Land Acquisition (HMLA)

Written documentation of the acquisition of the HM lands;

- Copies of all executed and recorded conservation easements;
- Written confirmation from the approved Endowment Manager of its receipt of the full Endowment; and
- Timely submission of all required reports.

Even if Security is provided, the Permittee must complete the required acquisition, protection and transfer of all HM lands and record any required conservation easements no later than **36 months** from the effective date of this ITP. CDFW may require the Permittee to provide additional HM lands and/or additional funding to ensure the impacts of the taking are minimized and fully mitigated, as required by law, if the Permittee does not complete these requirements within the specified timeframe.

X. Amendment:

This ITP may be amended as provided by California Code of Regulations, Title 14, section 783.6, subdivision (c), and other applicable law. This ITP may be amended without the concurrence of the

Incidental Take Permit
No. 2081-2020-037-06
(Amendment No. 2)
BALDY MESA SOLAR, LLC
BALDY MESA SOLAR PROJECT

Permittee as required by law, including if CDFW determines that continued implementation of the Project as authorized under this ITP would jeopardize the continued existence of the Covered Species or where Project changes or changed biological conditions necessitate an ITP amendment to ensure that all Project-related impacts of the taking to the Covered Species are minimized and fully mitigated.

XI. Stop-Work Order:

If CDFW determines the Permittee has violated any term or condition of this ITP or has engaged in unlawful take, CDFW may issue Permittee a written stop-work order instructing the Permittee to suspend any Covered Activity for an initial period of up to 30 days or risk suspension or revocation of this ITP. CDFW can issue a stop-work order to prevent or remedy a violation of this ITP, including but not limited to the failure to comply with reporting or monitoring obligations, or to prevent the unauthorized take of any CESA endangered, threatened, or candidate species, regardless of whether that species is a Covered Species under this ITP. Permittee shall stop work immediately as directed by CDFW upon receipt of any such stop-work order. Upon written notice to Permittee, CDFW may extend any stop-work order issued to Permittee for a period not to exceed 30 additional days.

If Permittee fails to remedy the violation or to comply with a stop-work order, CDFW may proceed with suspension and revocation of this ITP. Suspension and revocation of this ITP shall be governed by California Code of Regulations, Title 14, section 783.7, and any other applicable law. Neither the Designated Biologist nor CDFW shall be liable for any costs incurred in complying with stop-work orders.

XII. Liability:

All terms and conditions of this ITP shall be binding upon each Permittee. Notwithstanding California Civil Code section 1431 or any other provision of law, each Permittee shall be jointly and severally liable for performance of all terms, conditions, and obligations of this ITP and shall be jointly and severally liable for any unauthorized take or other violations of this ITP, whether committed by Permittees or any person acting on behalf of one or more Permittees, including their officers, employees, representatives, agents or contractors and subcontractors. Any failure by one or more Permittees to comply with any term, condition, or obligation herein shall be deemed a failure to comply by all Permittees.

XIII. Compliance with Other Laws:

This ITP sets forth CDFW's requirements for the Permittee to implement the Project pursuant to CESA. This ITP does not necessarily create an entitlement to proceed with the Project. Permittee is responsible for complying with all other applicable federal, state, and local law.

XIV. Notices:

The Permittee shall sign and return this ITP to CDFW. A manual or digital signature is acceptable, provided a digital signature complies with Government Code section 16.5. Digital signatures

Incidental Take Permit
No. 2081-2020-037-06
(Amendment No. 2)
BALDY MESA SOLAR, LLC
BALDY MESA SOLAR PROJECT

facilitated by CDFW will be automatically returned. Manual (wet) signatures on duplicate original paper copies shall be returned by the Permittee via registered first-class mail or overnight delivery to the following address:

Habitat Conservation Planning Branch
California Department of Fish and Wildlife
Attention: CESA Permitting Program
Post Office Box 944209
Sacramento, CA 94244-2090

Written notices, reports and other communications relating to this ITP shall be delivered to CDFW by email or registered first class mail at the following address, or at addresses CDFW may subsequently provide the Permittee. Notices, reports, and other communications shall reference the Project name, Permittee, and ITP Number (2081-2019-061-06) in a cover letter and on any other associated documents.

Original cover with attachment(s) to:

Regional Manager
California Department of Fish and Wildlife
3602 Inland Empire Boulevard, Suite C-220
Ontario, CA 91764
Telephone (909) 484-0167
AskRegion6@wildlife.ca.gov

and a copy to:

Habitat Conservation Planning Branch
California Department of Fish and Wildlife
Attention: CESA Permitting Program
Post Office Box 944209
Sacramento, CA 94244-2090
CESA@wildlife.ca.gov

Unless Permittee is notified otherwise, CDFW's Regional Representative for purposes of addressing issues that arise during implementation of this ITP is:

Rose Banks
3602 Inland Empire Boulevard, Suite C-220
Ontario, CA 91764
Telephone (760) 218-0022
Rose.Banks@wildlife.ca.gov

Incidental Take Permit
No. 2081-2020-037-06
(Amendment No. 2)
BALDY MESA SOLAR, LLC
BALDY MESA SOLAR PROJECT

XV. Compliance with the California Environmental Quality Act:

CDFW’s issuance of this ITP is subject to CEQA. CDFW is a responsible agency pursuant to CEQA with respect to this ITP because of prior environmental review of the Project by the lead agency, City of Adelanto. (See generally Pub. Resources Code, §§ 21067, 21069.) The lead agency’s prior environmental review of the Project is set forth in the Mitigated Negative Declaration (SCH No.: 2020090176) that the City of Adelanto approved for the Baldy Mesa Solar Project. At the time the lead agency certified the EIR and approved the Project it also adopted various mitigation measures for the Covered Species as conditions of Project approval.

This ITP, along with CDFW’s related CEQA findings, which are available as a separate document, provide evidence of CDFW’s consideration of the lead agency’s EIR for the Project and the environmental effects related to issuance of this ITP (CEQA Guidelines, § 15096, subd. (f)). CDFW finds that issuance of this ITP will not result in any previously undisclosed potentially significant effects on the environment or a substantial increase in the severity of any potentially significant environmental effects previously disclosed by the lead agency. Furthermore, to the extent the potential for such effects exists, CDFW finds adherence to and implementation of the Conditions of Project Approval adopted by the lead agency, and that adherence to and implementation of the Conditions of Approval imposed by CDFW through the issuance of this ITP, will avoid or reduce to below a level of significance any such potential effects. CDFW consequently finds that issuance of this ITP will not result in any significant, adverse impacts on the environment.

None of the factors that would trigger the need for subsequent or supplemental environmental analysis of the Project under Public Resources Code section 21166 or California Code of Regulations, Title 14, section 15162 and 15163, exist as a result of this Amendment.

XVI. Findings Pursuant to CESA:

These findings are intended to document CDFW’s compliance with the specific findings requirements set forth in CESA and related regulations. (Fish & G. Code § 2081, subs. (b)-(c); Cal. Code Regs., tit. 14, §§ 783.4, subds, (a)-(b), 783.5, subd. (c)(2).)

CDFW finds based on substantial evidence in the ITP application, Baldy Mesa Solar Project, the Baldy Mesa Solar Mitigated Negative Declaration, the results of consultations, and the administrative record of proceedings, that issuance of this ITP complies and is consistent with the criteria governing the issuance of ITPs pursuant to CESA:

- (1) Take of Covered Species as defined in this ITP will be incidental to the otherwise lawful activities covered under this ITP;
- (2) Impacts of the taking on Covered Species will be minimized and fully mitigated through the implementation of measures required by this ITP and as described in the MMRP. Measures include: (1) permanent habitat protection; (2) establishment of avoidance zones; (3) worker education; and (4) Quarterly Compliance Reports. CDFW evaluated factors including an

Incidental Take Permit
 No. 2081-2020-037-06
 (Amendment No. 2)
BALDY MESA SOLAR, LLC
BALDY MESA SOLAR PROJECT

assessment of the importance of the habitat in the Project Area, the extent to which the Covered Activities will impact the habitat, and CDFW's estimate of the acreage required to provide for adequate compensation. Based on this evaluation, CDFW determined that the protection and management for 612 acres of Mojave Ground Squirrel habitat, 612 acres of Desert Tortoise habitat, and 1,038 acres of Covered Species Western Joshua Tree compensatory habitat that is contiguous with other protected Covered Species habitat and/or is of higher quality than the habitat being destroyed by the Project, along with the minimization, monitoring, reporting, and funding requirements of this ITP minimizes and fully mitigates the impacts of the taking caused by the Project;

- (3) The take avoidance and mitigation measures required pursuant to the conditions of this ITP and its attachments are roughly proportional in extent to the impacts of the taking authorized by this ITP;
- (4) The measures required by this ITP maintain Permittee's objectives to the greatest extent possible;
- (5) All required measures are capable of successful implementation;
- (6) This ITP is consistent with any regulations adopted pursuant to Fish and Game Code sections 2112 and 2114;
- (7) Permittee has ensured adequate funding to implement the measures required by this ITP as well as for monitoring compliance with, and the effectiveness of, those measures for the Project; and
- (8) Issuance of this ITP will not jeopardize the continued existence of the Covered Species based on the best scientific and other information reasonably available, and this finding includes consideration of the species' capability to survive and reproduce, and any adverse impacts of the taking on those abilities in light of (1) known population trends; (2) known threats to the species; and (3) reasonably foreseeable impacts on the species from other related projects and activities. Moreover, CDFW's finding is based, in part, on CDFW's express authority to amend the terms and conditions of this ITP without concurrence of the Permittee as necessary to avoid jeopardy and as required by law.

XVII. Attachments:

FIGURE 1	Map of Project
ATTACHMENT 1	Mitigation Monitoring and Reporting Program
ATTACHMENT 2	Desert Tortoise Biologist Form
ATTACHMENT 3	GIS Data Collection Requirements
ATTACHMENT 4	Exclusion Fence

Incidental Take Permit
No. 2081-2020-037-06
(Amendment No. 2)
BALDY MESA SOLAR, LLC
BALDY MESA SOLAR PROJECT

ATTACHMENT 5
ATTACHMENT 6
ATTACHMENT 7
ATTACHMENT 8
ATTACHMENT 9

Raven Management Renewable Deposit Document
Irrevocable Letter of Credit
Mitigation Payment Transmittal Form
Minor Amendment No. 1 with Track Changes
Minor Amendment No. 2 with Track Changes

ISSUED BY THE CALIFORNIA DEPARTMENT OF FISH AND WILDLIFE ON October 29, 2024

DocuSigned by:

Heidi Calvert

CAEE4779B63E4A3...

Heidi Calvert, Regional Manager
Inland Deserts Region

Incidental Take Permit
No. 2081-2020-037-06
(Amendment No. 2)
BALDY MESA SOLAR, LLC
BALDY MESA SOLAR PROJECT

Baldy Mesa Solar Project

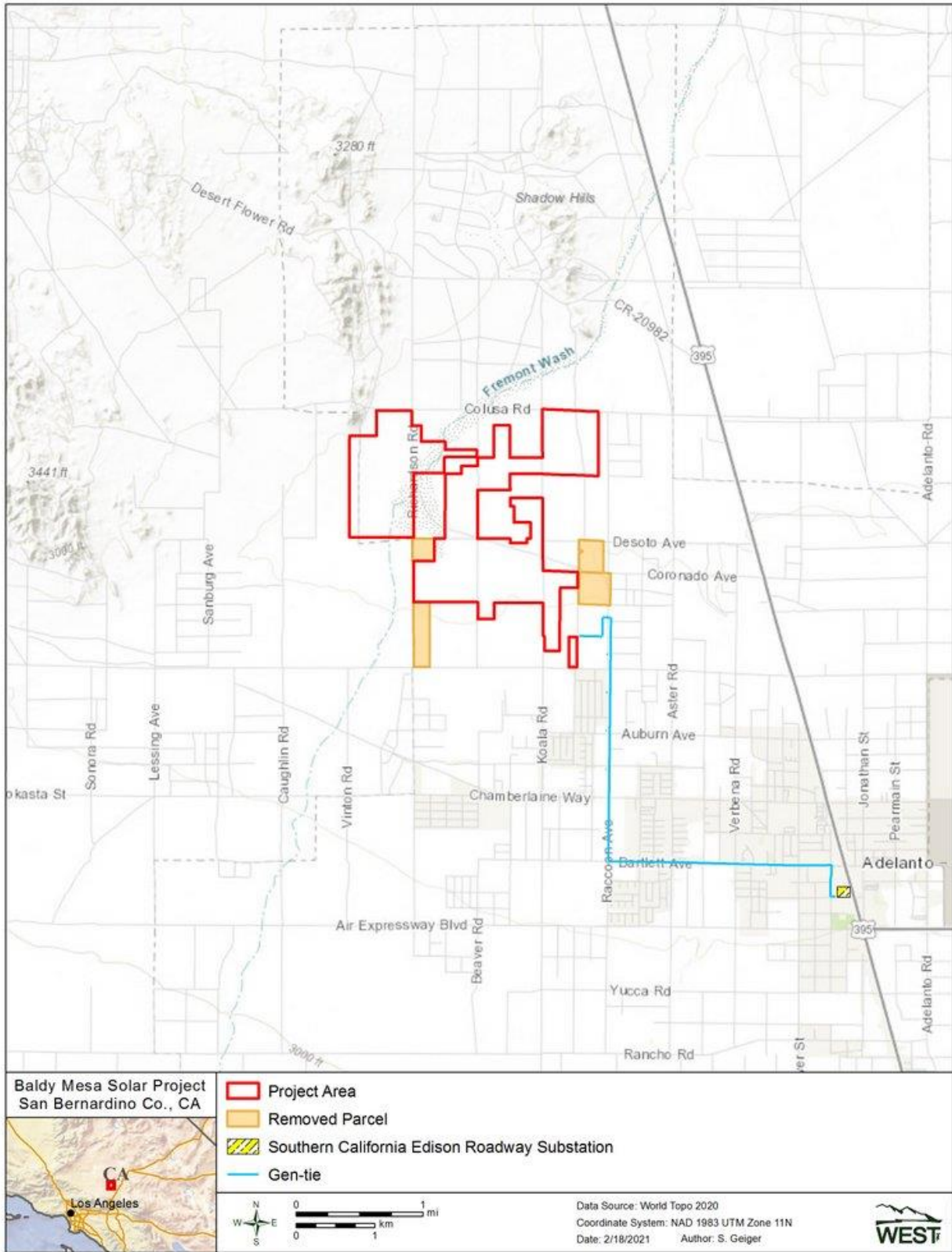

Figure 1. Location of the Baldy Mesa Solar Project, City of Adelanto, California.

Attachment 1

**CALIFORNIA DEPARTMENT OF FISH AND WILDLIFE
MITIGATION MONITORING AND REPORTING PROGRAM (MMRP)
CALIFORNIA ENDANGERED SPECIES ACT**

INCIDENTAL TAKE PERMIT NO. 2081-2020-037-06-A2

PERMITTEE: Baldy Mesa Solar, LLC

PROJECT: Baldy Mesa Solar Project

PURPOSE OF THE MMRP

The purpose of the MMRP is to ensure that the impact minimization and mitigation measures required by the Department of Fish and Wildlife (CDFW) for the above-referenced Project are properly implemented, and thereby to ensure compliance with section 2081(b) of the Fish and Game Code and section 21081.6 of the Public Resources Code. A table summarizing the mitigation measures required by CDFW is attached. This table is a tool for use in monitoring and reporting on implementation of mitigation measures, but the descriptions in the table do not supersede the mitigation measures set forth in the California Incidental Take Permit (ITP) and in attachments to the ITP, and the omission of a permit requirement from the attached table does not relieve the Permittee of the obligation to ensure the requirement is performed.

OBLIGATIONS OF PERMITTEE

Mitigation measures must be implemented within the time periods indicated in the table that appears below. Permittee has the primary responsibility for monitoring compliance with all mitigation measures and for reporting to CDFW on the progress in implementing those measures. These monitoring and reporting requirements are set forth in the ITP itself and are summarized at the front of the attached table.

VERIFICATION OF COMPLIANCE, EFFECTIVENESS

CDFW may, at its sole discretion, verify compliance with any mitigation measure or independently assess the effectiveness of any mitigation measure.

TABLE OF MITIGATION MEASURES

The following items are identified for each mitigation measure: Mitigation Measure, Source, Implementation Schedule, Responsible Party, and Status/Date/Initials. The Mitigation Measure column summarizes the mitigation requirements of the ITP. The Source column identifies the ITP condition that sets forth the mitigation measure. The Implementation Schedule column shows the date or phase when each mitigation measure will be implemented. The Responsible Party column identifies the person or agency that is primarily responsible for implementing the mitigation measure. The Status/Date/Initials column shall be completed by the Permittee during preparation of each Status Report and the Final Mitigation Report and must identify the implementation status of each mitigation measure, the date that status was determined, and the initials of the person determining the status.

	Mitigation Measure	Source	Implementation Schedule	Responsible Party	Status / Date / Initials
BEFORE DISTURBING SOIL OR VEGETATION					
1	Before starting Covered Activities, Permittee shall designate a representative (Designated Representative) responsible for communications with CDFW and overseeing compliance with this ITP. Permittee shall notify CDFW in writing before starting Covered Activities of the Designated Representative's name, business address, and contact information, and shall notify CDFW in writing if a substitute Designated Representative is selected or identified at any time during the term of this ITP.	ITP Condition # 5.1	Before commencing ground- or vegetation-disturbing activities/ Entire Project	Permittee	
2	Permittee shall designate Biological Monitor(s) (Biological Monitor(s)) knowledgeable and experienced in the biology and natural history of the Covered Species. The Biological Monitor(s) shall be responsible for monitoring Covered Activities to help minimize and fully mitigate or avoid the incidental take of individual Covered Species and to minimize disturbance of Covered Species' habitat. Permittee shall designate Authorized Biologist(s) (Authorized Biologist(s)) knowledgeable in the biology and natural history of the Covered Species. The Authorized Biologist(s) shall be responsible for monitoring Covered Activities to help minimize and fully mitigate and avoid the incidental take of individual Covered Species and to minimize disturbance of Covered Species' habitat. Additionally, the Authorized Biologist(s) shall have experience with all activities that will be carried out for the Project including, but not limited to, excavating burrows, handling and temporarily holding the Covered Species, relocating/translocating the Covered Species, reconstructing Covered Species burrows, unearthing and relocating Covered Species eggs, locating, identifying, and recording all forms of Covered Species signs, collecting Covered Species blood samples, conducting Covered Species health assessments, conducting Covered Species protocol level surveys, and/or attaching and removing transmitters to and from the Covered Species. Permittee shall obtain CDFW approval of the Authorized Biologist(s), Biological Monitor(s), and if needed veterinarian(s), in writing before starting Covered Activities, and shall also obtain advance written approval if any of these entities are changed. For approval, the Designated Representative shall submit Attachment 2 of this ITP and an Excel spreadsheet listing in alphabetical order the names of the proposed Authorized Biologist(s), Biological Monitor(s), and veterinarian(s) to CDFW a minimum of 21 calendar days before starting Covered Activities or before any changes are made to these personnel. For each proposed Authorized Biologist(s) and Biological Monitor(s), the Excel spreadsheet shall include the activities outlined in this ITP and associated Desert Tortoise Translocation Plan (DTTP) that the Permittee is requesting approval for that individual to carry out.	ITP Condition # 5.2,5.3, and 5.4	Before commencing ground- or vegetation-disturbing activities Entire Project	Permittee	

	Mitigation Measure	Source	Implementation Schedule	Responsible Party	Status / Date / Initials
3	Permittee shall conduct an education program for all persons employed or otherwise working in the Project Area before performing any work. The program shall consist of a presentation from the Designated Biologist that includes a discussion of the biology and general behavior of the Covered Species, information about the distribution and habitat needs of the Covered Species, sensitivity of the Covered Species to human activities, its status pursuant to CESA including legal protection, recovery efforts, penalties for violations and Project-specific protective measures described in this ITP. Permittee shall prepare and distribute wallet-sized cards or a fact sheet handout containing this information for workers to carry in the Project Area. Permittee shall provide interpretation for non-English speaking workers, and the same instruction shall be provided to any new workers before they are authorized to perform work in the Project Area. Upon completion of the program, employees shall sign a form stating they attended the program and understand all protection measures. This training shall be repeated at least once annually for long-term and/or permanent employees that will be conducting work in the Project Area. If the training program is presented as a prerecorded presentation, it shall be accompanied by a formal process that allows submission of questions that shall be answered by the Authorized Biologist(s) within 24 hours of submission.	ITP Condition #5.6	Before commencing ground- or vegetation-disturbing activities / Entire Project	Permittee	
4	Permittee shall initiate a trash abatement program before starting Covered Activities and shall continue the program for the duration of the Project. Permittee shall ensure that trash and food items are contained in animal-proof containers and removed, ideally at daily intervals but at least once a week, to avoid attracting opportunistic predators such as ravens, coyotes, and feral dogs.	ITP Condition # 5.8	Before commencing ground- or vegetation-disturbing activities Entire Project	Permittee	
5	Permittee shall clearly delineate habitat of the Covered Species within the Project Area with posted signs, posting stakes, flags, and/or rope or cord, and place fencing as necessary to minimize the disturbance of Covered Species' habitat.	ITP Condition # 5.12	Before commencing ground- or vegetation-disturbing activities / Entire Project	Permittee	
6	Project-related personnel shall access the Project Area using existing routes, or routes identified in the Project Description and shall not cross Covered Species' habitat outside of or en route to the Project Area; cross-country (off-road) vehicle travel shall be prohibited unless specifically accounted for as a Covered Activity. Permittee shall restrict Project-related vehicle traffic to established roads, staging, and parking areas. Project-related vehicle traffic shall not exceed 25 miles per hour, except in Covered Species habitat where vehicle speed shall not exceed 15 miles per hour. If Permittee determines construction of routes for travel are necessary outside of the Project Area, the Designated Representative shall contact CDFW for written approval before carrying out such an activity. CDFW may require an amendment to this ITP, among other reasons, if additional take of Covered Species will occur as a result of the Project modification.	ITP Condition # 5.13	Before commencing ground- or vegetation-disturbing activities / Entire Project	Permittee	
7	Permittee shall confine all Project-related parking, storage areas, laydown sites, equipment storage, and any other surface-disturbing activities to the Project Area using, to the extent possible, previously disturbed areas. Additionally, Permittee shall not use or cross Covered Species' habitat outside of the marked Project Area unless provided for as described in Condition of Approval 5.11 of this ITP.	ITP Condition # 5.14	Before commencing ground- or vegetation-disturbing activities	Permittee	

	Mitigation Measure	Source	Implementation Schedule	Responsible Party	Status / Date / Initials
8	The Designated Representative shall notify CDFW 14 calendar days before starting Covered Activities and shall document compliance with all pre-Project Conditions of Approval before starting Covered Activities.	ITP Condition #6.1	Before commencing ground- or vegetation-disturbing activities	Permittee	
9	The Permittee shall prepare a Raven Management Plan to minimize the potential to attract common ravens to the site and submit it to CDFW for review and approval. In addition, the Permittee shall provide funds to the Renewable Energy Action Team (REAT) account established with the National Fish and Wildlife Foundation (NFWF) to contribute to a region-wide raven control plan to help address raven predation on the tortoise. This contribution shall be used to address raven predation on a regional basis and shall be calculated as a one-time payment of \$105 per acre of project disturbance. Based on this calculation the Permittee shall provide a one-time payment at \$105.00/acre for 1,150 acres at \$120,750.00 to the REAT account established with NFWF's Raven Management Plan fund. A minimum of 30 days prior to the start of Covered Activities these funds shall be provided to NFWF using appropriate deposit document (Attachment 5) and proof of paying this fee shall be provided to CDFW within 24 hours after the funds have been provided to NFWF.	ITP Condition # 7.19	Before commencing ground- or vegetation-disturbing activities (or within 36 months from initiation of Covered Activities if Security is provided)	Permittee	
10	Permittee shall either purchase 612 acres of Covered Species Mojave Ground Squirrel credits, 612 acres of Covered Species Desert Tortoise credits, and 1,038 acres of Covered Species Western Joshua Tree credits from a CDFW-approved mitigation or conservation bank pursuant to Condition of Approval 9.2 below OR shall provide for both the permanent protection and management of 612 acres of Covered Species Mojave Ground Squirrel, 612 acres of Covered Species Desert Tortoise, and 1,038 acres of Covered Species Western Joshua Tree Habitat Management (HM) lands pursuant to Condition of Approval 8.3 below and the calculation and deposit of the management funds pursuant to Condition of Approval 9.4 below. Purchase of Covered Species credits OR permanent protection and funding for perpetual management of HM lands must be complete before starting Covered Activities, or within 36 months of the effective date of this ITP if Security is provided pursuant to Condition of Approval 9 below for all uncompleted obligations.	ITP Condition # 8	Before commencing ground- or vegetation-disturbing activities (or within 36 months from initiation of Covered Activities if Security is provided)	Permittee	

	Mitigation Measure	Source	Implementation Schedule	Responsible Party	Status / Date / Initials
11	<p>CDFW has estimated the cost of acquisition, protection, and perpetual management of the HM lands as follows:</p> <ul style="list-style-type: none"> 8.1.1. Land acquisition costs for HM lands identified in Condition of Approval 9.3 below, estimated at \$2,500.00/acre for 1,038 acres: \$2,595,000.00. Land acquisitions costs are estimated using local fair market current value per acre for lands with habitat values meeting mitigation requirements; 8.1.2. All other costs necessary to review and acquire the land in fee title and record a conservation easement as described in Condition of Approval 9.3.1 and 9.3.2 below: \$17,440.00. 8.1.3. Start-up costs for HM lands, including initial site protection and enhancement costs as described in Condition of Approval 9.3.6 below, estimated at \$2,000.00/acre for 1,038 acres: \$2,076,000.00; including. 8.1.4. Interim management period funding as described in Condition of Approval 9.3.7 below, estimated at \$600.00/acre for 1,038 acres: \$622,800.00. 8.1.5. Long-term management funding as described in Condition of Approval 9.4 below, estimated at \$3,100.00/acre for 1038 acres: \$3,217,800.00. Long-term management funding is estimated initially for the purpose of providing Security to ensure implementation of HM lands management. 8.1.6. Related transaction fees including but not limited to account set-up fees, administrative fees, title and documentation review and related title transactions, expenses incurred from other state agency reviews, and overhead related to transfer of HM lands to CDFW as described in Condition of Approval 9.5, estimated at \$6,000.00. 8.1.7. All costs associated with CDFW engaging an outside contractor to complete the mitigation tasks, including but not limited to acquisition, protection, and perpetual funding and management of the HM lands and restoration of temporarily disturbed habitat. These costs include but are not limited to the cost of issuing a request for proposals, transaction costs, contract administration costs, and costs associated with monitoring the contractor's work \$75,000.00. 	ITP Condition #8.1	Before commencing ground- or vegetation-disturbing activities (or within 36 months from initiation of Covered Activities if Security is provided)	Permittee	
12	<p>If the Permittee elects to purchase Covered Species credits to complete compensatory mitigation obligations, then Permittee shall purchase 612 acres of Covered Species Mojave Ground Squirrel credits, 612 acres of Covered Species Desert Tortoise credits, and 1,038 acres of Covered Species Western Joshua Tree credits from a CDFW-approved mitigation or conservation bank prior to initiating Covered Activities, or no later than 36 months from the issuance of this ITP if Security is provided pursuant to Condition of Approval 9 below. Prior to purchase of Covered Species credits, Permittee shall obtain CDFW approval to ensure the mitigation or conservation bank is appropriate to compensate for the impacts of the Project. Permittee shall submit to CDFW a copy of the Bill of Sale(s) and Payment Receipt prior to initiating Covered Activities or within 36 months from issuance of this ITP if Security is provided.</p>	ITP Condition #8.2	Before commencing ground- or vegetation-disturbing activities (or within 36 months from initiation of Covered Activities if Security is provided)	Permittee	

	Mitigation Measure	Source	Implementation Schedule	Responsible Party	Status / Date / Initials
13	To provide for the acquisition and protection of the HM lands, the Permittee shall transfer fee title of the HM lands to CDFW pursuant to terms approved in writing by CDFW. Alternatively, CDFW, in its sole discretion, may authorize a governmental entity, special district, non-profit organization, for-profit entity, person, or another entity to hold title to and manage the property provided that the district, organization, entity, or person meets the requirements of Government Code sections 65965-65968, as amended.	ITP Condition #8.3.1	Before commencing ground- or vegetation-disturbing activities (or within 36 months from initiation of Covered Activities if Security is provided)	Permittee	
14	If CDFW does not hold fee title to the HM lands, CDFW shall act as grantee for a conservation easement over the HM lands or shall, in its sole discretion, approve a non-profit entity, public agency, or Native American tribe to act as grantee for a conservation easement over the HM lands provided that the entity, agency, or tribe meets the requirements of Civil Code section 815.3. If CDFW elects not to be named as the grantee for the conservation easement, CDFW shall be expressly named in the conservation easement as a third-party beneficiary. The Permittee shall obtain CDFW written approval of any conservation easement before its execution or recordation. No conservation easement shall be approved by CDFW unless it complies with Civil Code sections 815-816, as amended, and Government Code sections 65965-65968, as amended and includes provisions expressly addressing Government Code sections 65966(j) and 65967(e). Because the "doctrine of merger" could invalidate the conservation interest, under no circumstances can the fee title owner of the HM lands serve as grantee for the conservation easement.	ITP Condition 8.3.2	Before commencing ground- or vegetation-disturbing activities (or within 36 months from initiation of Covered Activities if Security is provided)	Permittee	
15	Permittee shall obtain CDFW written approval of the HM lands before acquisition and/or transfer of the land by submitting, at least three months before acquisition and/or transfer of the HM lands, documentation identifying the land to be purchased, or property interest conveyed to an approved entity as mitigation for the Project's impacts on Covered Species;	ITP Condition #8.3.3	Before commencing ground- or vegetation-disturbing activities (or within 36 months from initiation of Covered Activities if Security is provided)	Permittee	
16	Permittee shall provide a recent preliminary title report, Phase I Environmental Site Assessment, and other necessary documents (please contact CDFW for document list). All documents conveying the HM lands, and all conditions of title are subject to the approval of CDFW, and if applicable, the Wildlife Conservation Board and the Department of General Services.	ITP Condition #8.3.4	Before commencing ground- or vegetation-disturbing activities (or within 36 months from initiation of Covered Activities if Security is provided)	Permittee	

	Mitigation Measure	Source	Implementation Schedule	Responsible Party	Status / Date / Initials
17	Permittee shall designate both an interim and long-term land manager approved by CDFW. The interim and long-term land managers may, but need not, be the same. The interim and/or long-term land managers may be the landowner or another party. Documents related to land management shall identify both the interim and long-term land managers. Permittee shall notify CDFW of any subsequent changes in the land manager within 30 days of the change. If CDFW will hold fee title to the mitigation land, CDFW will also act as both the interim and long-term land manager unless otherwise specified. The grantee for the conservation easement cannot serve as the interim or long-term manager without the express written authorization of CDFW in its sole discretion.	ITP Condition #8.3.5	Before commencing ground- or vegetation-disturbing activities (or within 36 months from initiation of Covered Activities if Security is provided)	Permittee	
18	Permittee shall provide for the implementation of start-up activities, including the initial site protection and enhancement of HM lands, once the HM lands have been approved by CDFW. Start-up activities include, at a minimum: (1) preparing a final management plan for CDFW approval (see https://nrm.dfg.ca.gov/FileHandler.ashx?DocumentID=137386&inline) (2) conducting a baseline biological assessment and land survey report within four months of recording or transfer; (3) developing and transferring Geographic Information Systems (GIS) data if applicable; (4) establishing initial fencing; (5) conducting litter removal; (6) conducting initial habitat restoration or enhancement, if applicable; and (7) installing signage.	ITP Condition #8.3.6	Before commencing ground- or vegetation-disturbing activities (or within 36 months from initiation of Covered Activities if Security is provided)	Permittee	
19	Permittee shall provide for the interim management of the HM lands. The Permittee shall ensure that the interim land manager implements the interim management of the HM lands as described in the final management plan and conservation easement approved by CDFW. The interim management period shall be a minimum of three years from the date of HM land acquisition and protection and full funding of the Endowment and includes expected management following start-up activities. Interim management period activities described in the final management plan shall include fence repair, continuing trash removal, site monitoring, and vegetation and invasive species management. Permittee shall either (1) provide Security to CDFW for the minimum of three years of interim management that the land owner, Permittee, or land manager agrees to manage and pay for at their own expense, (2) establish an escrow account with written instructions approved in advance in writing by CDFW to pay the land manager annually in advance, or (3) establish a short-term enhancement account with CDFW or a CDFW-approved entity for payment to the land manager.	ITP Condition #8.3.7	Before commencing ground- or vegetation-disturbing activities (or within 36 months from initiation of Covered Activities if Security is provided)	Permittee	

	Mitigation Measure	Source	Implementation Schedule	Responsible Party	Status / Date / Initials
20	<p>If the Permittee elects to provide for the acquisition, permanent protection, and perpetual management of HM lands to complete compensatory mitigation obligations, then Permittee shall ensure that the HM lands are perpetually managed, maintained, and monitored by the long-term land manager as described in this ITP, the conservation easement, and the final management plan approved by CDFW. After obtaining CDFW approval of the HM lands, Permittee shall provide long-term management funding for the perpetual management of the HM lands by establishing a long-term management fund (Endowment). The Endowment is a sum of money, held in a CDFW-approved fund that is permanently restricted to paying the costs of long-term management and stewardship of the mitigation property for which the funds were set aside, which costs include the perpetual management, maintenance, monitoring, and other activities on the HM lands consistent with this ITP, the conservation easement, and the management plan required by Condition of Approval 8.3.5. Endowment as used in this ITP shall refer to the endowment deposit and all interest, dividends, other earnings, additions and appreciation thereon. The Endowment shall be governed by this ITP, Government Code sections 65965-65968, as amended, and Probate Code sections 18501-18510, as amended.</p> <p>After the interim management period, Permittee shall ensure that the designated long-term land manager implements the management and monitoring of the HM lands according to the final management plan. The long-term land manager shall be obligated to manage and monitor the HM lands in perpetuity to preserve their conservation values in accordance with this ITP, the conservation easement, and the final management plan. Such activities shall be funded through the Endowment.</p>	ITP Condition #8.4	Before commencing ground- or vegetation-disturbing activities (or within 36 months from initiation of Covered Activities if Security is provided)	Permittee	
21	<p>The Endowment shall be held by the Endowment Manager, which shall be either CDFW or another entity qualified pursuant to Government Code sections 65965-65968, as amended.</p> <p>Permittee shall submit to CDFW a written proposal that includes: (i) the name of the proposed Endowment Manager; (ii) whether the proposed Endowment Manager is a governmental entity, special district, nonprofit organization, community foundation, or congressionally chartered foundation; (iii) whether the proposed Endowment Manager holds the property or an interest in the property for conservation purposes as required by Government Code section 65968(b)(1) or, in the alternative, the basis for finding that the Project qualifies for an exception pursuant to Government Code section 65968(b)(2); and (iv) a copy of the proposed Endowment Manager's certification pursuant to Government Code section 65968(e).</p> <p>Within thirty days of CDFW's receipt of Permittee's written proposal, CDFW shall inform Permittee in writing if it determines the proposal does not satisfy the requirements of Fish and Game Code section 2081(b)(3) and, if so, shall provide Permittee with a written explanation of the reasons for its determination. If CDFW does not provide Permittee with a written determination within the thirty-day period, the proposal shall be deemed consistent with Section 2081(b)(3).</p>	ITP Conditions #8.4.1	Before commencing ground- or vegetation-disturbing activities (or within 36 months from initiation of Covered Activities if Security is provided)	Permittee	

	Mitigation Measure	Source	Implementation Schedule	Responsible Party	Status / Date / Initials
22	<p>After obtaining CDFW written approval of the HM lands, long-term management plan, and Endowment Manager, Permittee shall prepare an endowment assessment (equivalent to a Property Analysis Record (PAR)) to calculate the amount of funding necessary to ensure the long-term management of the HM lands (Endowment Deposit Amount). Note that the endowment for the easement holder should not be included in this calculation. The Permittee shall submit to CDFW for review and approval the results of the endowment assessment before transferring funds to the Endowment Manager.</p> <p><u>Capitalization Rate and Fees.</u> Permittee shall obtain the capitalization rate from the selected Endowment Manager for use in calculating the endowment assessment and adjust for any additional administrative, periodic, or annual fees.</p> <p><u>Endowment Buffers/Assumptions.</u> Permittee shall include in the endowment assessment assumptions the following buffers for endowment establishment and use that will substantially ensure long-term viability and security of the Endowment:</p> <ul style="list-style-type: none"> • <u>10 Percent Contingency.</u> A 10 percent contingency shall be added to each endowment calculation to hedge against underestimation of the fund, unanticipated expenditures, inflation, or catastrophic events. • <u>Three Years Delayed Spending.</u> The endowment shall be established assuming spending will not occur for the first three years after full funding. • <u>Non-annualized Expenses.</u> For all large capital expenses to occur periodically but not annually such as fence replacement or well replacement, payments shall be withheld from the annual disbursement until the year of anticipated need or upon request to Endowment Manager and CDFW. 	ITP Conditions #8.4.2	Before commencing ground- or vegetation-disturbing activities (or within 36 months from initiation of Covered Activities if Security is provided)	Permittee	
23	Permittee shall transfer the long-term endowment funds to the Endowment Manager upon CDFW approval of the Endowment Deposit Amount identified above.	ITP Conditions #8.4.3	Before commencing ground- or vegetation-disturbing activities (or within 36 months from initiation of Covered Activities if Security is provided)	Permittee	

	Mitigation Measure	Source	Implementation Schedule	Responsible Party	Status / Date / Initials
24	<p>The approved Endowment Manager may pool the Endowment with other endowments for the operation, management, and protection of HM lands for local populations of the Covered Species but shall maintain separate accounting for each Endowment. The Endowment Manager shall, at all times, hold and manage the Endowment in compliance with this ITP, Government Code sections 65965-65968, as amended, and Probate Code sections 18501-18510, as amended.</p> <p>Notwithstanding Probate Code sections 18501-18510, the Endowment Manager shall not make any disbursement from the Endowment that will result in expenditure of any portion of the principal of the endowment without the prior written approval of CDFW in its sole discretion. Permittee shall ensure that this requirement is included in any agreement of any kind governing the holding, investment, management, and/or disbursement of the Endowment funds.</p> <p>Notwithstanding Probate Code sections 18501-18510, if CDFW determines in its sole discretion that an expenditure needs to be made from the Endowment to preserve the conservation values of the HM lands, the Endowment Manager shall process that expenditure in accordance with directions from CDFW. The Endowment Manager shall not be liable for any shortfall in the Endowment resulting from CDFW's decision to make such an expenditure.</p>	ITP Conditions #8.4.4	Before commencing ground- or vegetation-disturbing activities (or within 36 months from initiation of Covered Activities if Security is provided)		
25	<p>Permittee shall reimburse CDFW for all reasonable costs incurred by CDFW related to issuance and monitoring of this ITP, including, but not limited to transaction fees, account set-up fees, administrative fees, title and documentation review and related title transactions, costs incurred from other state agency reviews, and overhead related to transfer of HM lands to CDFW.</p>	ITP Conditions #8.5	Before commencing ground- or vegetation-disturbing activities (or within 36 months from initiation of Covered Activities if Security is provided)	Permittee	

	Mitigation Measure	Source	Implementation Schedule	Responsible Party	Status / Date / Initials
26	<p>The Permittee may proceed with Covered Activities only after the Permittee has ensured funding (Security) to complete any activity required by Condition of Approval 8 that has not been completed before Covered Activities begin. Permittee shall provide Security as follows:</p> <ol style="list-style-type: none"> 9.1. <u>Security Amount</u>. The Security shall be in the amount of \$8,635,040.00 or in the amount identified in 8.1 specific to the obligation that has not been completed. This amount is determined by CDFW based on the cost estimates identified in Condition of Approval 8.1 above, sufficient for CDFW or its contractors to complete land acquisition, property enhancement, startup costs, initial management, long-term management, and monitoring. 9.2. <u>Security Form</u>. The Security shall be in the form of an irrevocable letter of credit (see Attachment 6), or another form of Security approved in advance in writing by CDFW's Office of the General Counsel. 9.3. <u>Security Timeline</u>. The Security shall be provided to CDFW before Covered Activities begin. 9.4. <u>Security Holder</u>. The Security shall be held by CDFW or in a manner approved in advance in writing by CDFW. 9.5. <u>Security Transmittal</u>. Permittee shall transmit it to CDFW with a completed Mitigation Payment Transmittal Form (see Attachment 7) or by way of an approved instrument such as an escrow agreement, irrevocable letter of credit, or other. 9.6. <u>Security Drawing</u>. The Security shall allow CDFW to draw on the principal sum if CDFW, in its sole discretion, determines that the Permittee has failed to comply with the Conditions of Approval of this ITP. 9.7. <u>Security Release</u>. The Security (or any portion of the Security then remaining) shall be released to the Permittee after CDFW has conducted an on-site inspection and received confirmation that all secured requirements have been satisfied, as evidenced by: <p>Credit Purchase</p> <ul style="list-style-type: none"> • Copy of Bill of Sale(s) and Payment Receipt(s) or Credit Transfer Agreement for the purchase of Covered Species credits; and • Timely submission of all required reports. <p>Habitat Management Land Acquisition (HMLA)</p> <p>Written documentation of the acquisition of the HM lands;</p> <ul style="list-style-type: none"> • Copies of all executed and recorded conservation easements; • Written confirmation from the approved Endowment Manager of its receipt of the full Endowment; and • Timely submission of all required reports. <p>Even if Security is provided, the Permittee must complete the required acquisition, protection and transfer of all HM lands and record any required conservation easements no later than 36 months from the effective date of this ITP. CDFW may require the Permittee to provide additional HM lands and/or additional funding to ensure the impacts of the taking are minimized and fully mitigated, as required by law, if the Permittee does not complete these requirements within the specified timeframe.</p>	ITP Condition # 9	Before commencing ground- or vegetation-disturbing activities (or within 36 months from initiation of Covered Activities if Security is provided)	Permittee	

	Mitigation Measure	Source	Implementation Schedule	Responsible Party	Status / Date / Initials
DURING CONSTRUCTION					
27	The Biological Monitor(s) and Authorized Biologist(s) shall maintain construction-monitoring documentation on-site in either hard copy or digital format throughout the construction period, which shall include a copy of this ITP with attachments and a list of signatures of all personnel who have successfully completed the education program. Permittee shall ensure a copy of the construction-monitoring documentation is available for review at the Project site upon request by CDFW.	ITP Condition # 5.7	During Construction on Entire Project	Permittee	
28	Permittee shall implement dust control measures during Covered Activities to facilitate visibility for monitoring of the Covered Species by the Designated Biologist. Permittee shall keep the amount of water used to the minimum amount needed and shall not allow water to form puddles.	ITP Condition # 5.9	During Construction on Entire Project	Permittee	
29	Permittee shall immediately stop and, pursuant to pertinent state and federal statutes and regulations, arrange for repair and clean up by qualified individuals of any fuel or hazardous waste leaks or spills at the time of occurrence, or as soon as it is safe to do so. Permittee shall exclude the storage and handling of hazardous materials from the Project Area and shall properly contain and dispose of any unused or leftover hazardous products off-site.	ITP Condition # 5.15	During Construction on Entire Project	Permittee	
30	Permittee shall provide CDFW staff with reasonable access to the Project and mitigation lands under Permittee control and shall otherwise fully cooperate with CDFW efforts to verify compliance with or effectiveness of mitigation measures set forth in this ITP.	ITP Condition # 5.16	During Construction on Entire Project	Permittee	
31	Permittee shall prohibit Project personnel, and any other individuals associated with the Project from bringing any firearms or dogs on the Project Area during Covered Activities, except those in the possession of authorized security personnel or local, state, or federal law enforcement officials, dogs that may be used to aid in official and approved monitoring procedures/protocols, or service dogs under Title II and Title III of the American with Disabilities Act.	ITP Condition #5.19	During Construction on Entire Project	Permittee	
32	The Designated Representative shall immediately notify CDFW if the Permittee is not in compliance with any Condition of Approval of this ITP, including but not limited to any actual or anticipated failure to implement measures within the time periods indicated in this ITP and/or the MMRP. The Designated Representative shall follow up within 24 hours with a written report to CDFW describing, in detail, any non-compliance with this ITP and suggested measures to remedy the situation.	ITP Condition # 6.2	During Construction on Entire Project	Permittee	
33	Permittee shall immediately notify the Biological Monitor(s) and/or Authorized Biologist(s) if a Covered Species is taken or injured by a Project-related activity, or if a Covered Species is otherwise found dead or injured within the vicinity of the Project. The Biological Monitor(s), Authorized Biologist(s), or Designated Representative shall provide initial notification to CDFW by following Condition of Approval 7.5. The initial notification to CDFW shall include information regarding the location, species, and number of animals/plants taken or injured/damaged and the ITP Number. Following initial notification, Permittee shall send CDFW a written report within three calendar days. The report shall include the date and time of the finding or incident, location of the animal or carcass, and if possible, provide a photograph, explanation as to cause of take or injury, and any other pertinent information.	ITP Condition #6.3	During Construction on Entire Project	Permittee	

	Mitigation Measure	Source	Implementation Schedule	Responsible Party	Status / Date / Initials
34	<p>The Biological Monitor(s) and/or Authorized Biologist(s) shall be on-site daily when Covered Activities occur. The Biological Monitor(s) and/or Authorized Biologist(s) shall conduct compliance inspections a minimum of to:</p> <ol style="list-style-type: none"> (1) minimize incidental take of the Covered Species; (2) prevent unlawful take of species; (3) check for compliance with all measures of this ITP; (4) check all exclusion zones; and (5) ensure that signs, stakes, and fencing are intact, and that Covered Activities are only occurring in the Project Area. <p>The Designated Representative, Biological Monitor(s), and/or Authorized Biologist(s) shall prepare daily written observation and inspection records summarizing oversight activities and compliance inspections, observations of Covered Species and their sign, survey results, and monitoring activities required by this ITP. The Authorized Biologist(s) and/or Biological Monitor shall conduct compliance inspections a minimum of three times a day (once during the onset of the day's work, once mid-day, and once at the conclusion of that day's work).</p>	ITP Condition # 6.6	During Construction on Entire Project	Permittee	
35	<p>The Designated Representative, Biological Monitor(s), and/or Authorized Biologist(s) shall compile the observation and inspection records identified in Condition of Approval 7.6 into a Quarterly Compliance Report and submit it to CDFW along with a copy of the MMRP table with notes showing the current implementation status of each mitigation measure. Quarterly Compliance Reports shall be submitted to the CDFW offices listed in the Notices section of this ITP and via e-mail to CDFW's Regional Representative and Headquarters CESA Program. At the time of this ITP's approval, the CDFW Regional Representative Rose Banks (Rose.Banks@wildlife.ca.gov) and Headquarters CESA Program email is CESA@wildlife.ca.gov. CDFW may at any time increase the timing and number of compliance inspections and reports required under this provision depending upon the results of previous compliance inspections. If CDFW determines the reporting schedule must be changed, CDFW will notify Permittee in writing of the new reporting schedule.</p>	ITP Condition # 6.7	During Construction on Entire Project	Permittee	
36	<p>Permittee shall provide CDFW with an Annual Status Report (ASR) no later than January 31 of every year beginning with issuance of this ITP and continuing until CDFW accepts the Final Mitigation Report identified below. Each ASR shall include, at a minimum: (1) a summary of all Quarterly Compliance Reports for that year identified in Condition of Approval 7.7; (2) a general description of the status of the Project Area and Covered Activities, including actual or projected completion dates, if known; (3) a copy of the table in the MMRP with notes showing the current implementation status of each mitigation measure; (4) an assessment of the effectiveness of each completed or partially completed mitigation measure in avoiding, minimizing and mitigating Project impacts; (5) all available information about Project-related incidental take of the Covered Species; and (6) information about other Project impacts on the Covered Species.</p>	ITP Condition # 6.8	During Construction on Entire Project	Permittee	
37	<p>The Designated Representative shall submit all observations of Covered Species to CDFW's California Natural Diversity Database (CNDDDB) within 60 calendar days of the observation and the Designated Representative shall include copies of the submitted forms with the next Quarterly Compliance Report or ASR, whichever is submitted first relative to the observation. More information is available at https://www.wildlife.ca.gov/Data/CNDDDB.</p>	ITP Condition #6.9	During Construction on Entire Project	Permittee	

	Mitigation Measure	Source	Implementation Schedule	Responsible Party	Status / Date / Initials
38	<p>No later than 30 days prior to start of Covered Activities, the Authorized Biologist(s) and/or Biological Monitor(s) approved under this ITP shall conduct pre-construction clearance surveys for Covered Species, using the methods described in the most recent United States Fish and Wildlife Service (USFWS) Desert Tortoise (Mojave Population) Field Manual (hereinafter referred to as USFWS Field Manual). In addition to the guidance provided in the USFWS Field Manual, CDFW provides the following requirement(s):</p> <ul style="list-style-type: none"> • Pre-construction clearance surveys shall be completed using perpendicular survey routes within the Project Area. Pre-construction clearance surveys cannot be combined with other clearance surveys conducted for other species while using the same personnel. Covered Activities cannot start until two (2) negative results from consecutive surveys using perpendicular survey routes for the Covered Species are documented. • These surveys shall cover 100 percent of the Project Area and a 50-foot buffer zone around the Project site. The Biological Monitor(s) and/or Authorized Biologist(s) shall record all potential Covered Species and burrows within the pre-construction clearance survey area, using global positioning system (GPS) technology. The Biological Monitor(s) and/or Authorized Biologist(s) shall provide the results of the pre-construction clearance survey (including all information of the USFWS Protocol data sheet) to CDFW within 10 Calendar days of completing the surveys. The use of specialized equipment (e.g., fiber optics) may be necessary to thoroughly inspect all burrows in preparation for collapsing them. • Twenty-Four (24) hours prior to the start of any Covered Activities, except for areas already cleared within installation of permanent desert tortoise exclusion fencing (Condition of Approval 8.13), the Biological Monitor(s) and/or Authorized Biologist(s) shall conduct a final clearance survey of Project Area. The use of specialized equipment (e.g., fiber optics) may be necessary to thoroughly inspect all burrows in preparation for collapsing them. 	ITP Condition # 7.5	During Construction on Entire Project	Permittee	
39	<p>No more than 30 calendars days prior to the start of ground disturbing activities the Authorized Biologist(s)/Biological Monitor(s) shall be present onsite to perform a pre-construction survey for MGS. These surveys shall cover the Project Area and a 50-foot buffer zone. All known or suspected MGS burrows within the work areas shall be flagged to alert biological and work crews to their presence. A report documenting the results of the pre-construction surveys shall be submitted to CDFW within 30 calendar days after performing them.</p>	ITP Condition #7.6	During Construction on Project Site	Permittee	

	Mitigation Measure	Source	Implementation Schedule	Responsible Party	Status / Date / Initials
40	If a Covered Species is observed during Covered Activities, all work within 300feet of the Covered Species shall immediately stop and the observation shall be immediately reported to the Authorized Biologist(s). Covered Activities shall not resume until the Authorized Biologist(s) and/or Biological Monitor(s) has verified the Covered Species has left the Project Area OR an Authorized Biologist(s) approved under Condition of Approval 5.4 of this ITP relocates the Covered Species as described in this ITP and Desert Tortoise Translocation Plan. The Designated Representative shall notify CDFW of any Covered Species observations within the Project Area. Notification shall occur as described in Condition of Approval 6.5 within 24 hours. Notification and the written report shall include the date, location, and circumstances of the observation, the name of the Authorized Biologist(s) that relocated the individual, pictures, map and shapefiles with the location (including GPS coordinates) where the individual was moved as specified in the DTTP.	ITP Condition #7.7	During Construction on Project Site	Permittee	
41	The Authorized Biologist(s) shall fully excavate by hand all burrows OR scope each burrow within the Project Area that are suspected or known to be occupied by Mohave ground squirrels. The Authorized Biologist(s) shall allow Mohave ground squirrels encountered in the excavated burrows during their active period (March 15 – July 15) to escape out of harm’s way. During the Mohave ground squirrel dormant period (September 1 – January 31), the Authorized Biologist(s) shall collect and immediately relocate the individuals to an artificial burrow in the following preferential order: 1.) relocate to the nearest public lands with suitable habitat from where the squirrel was originally captured; 2.) relocate outside of right-of-way, within existing parcel on private property. Mohave ground squirrels may not be relocated to private property unless the Permittee obtains written permission from the property owner prior to Covered Activities. The Mohave ground squirrel may only be relocated by the Authorized Biologist(s). The Authorized Biologist(s) shall prepare relocation burrows in the following manner: (1) A hole of at least two feet deep shall be dug; (2) Install a nine-inch diameter non-collapsible plastic container, which shall be connected to a three-inch diameter non-collapsible plastic pipe that runs to the ground surface at a 45-degree angle; (3) The Authorized Biologist(s) shall place the Mohave ground squirrel in the artificial burrow and lightly plug the burrow mouth with soil in a manner that is similar to a natural Mohave ground squirrel burrow.	ITP Condition #7.9	During Construction on Project Site	Permittee	
42	Regardless of the number of Covered Species estimated to be moved out of harm’s way the Permittee shall prepare a modified Desert Tortoise Translocation Plan (DTTP) to address only moving desert tortoise out of harm’s way 15 Calendar days prior to start of Covered Activities and submit it according to condition of approval 6.5 of this ITP. Covered Activities are not authorized to start until the DTTP is approved in writing by CDFW. The DTTP shall follow the most current guidelines provided by USFWS and CDFW regarding Covered Species translocation. Where guidance differs between USFWS and CDFW, verbal and/or written direction provided by CDFW always controls.	ITP Condition #7.10	During Construction on Project Site	Permittee	

	Mitigation Measure	Source	Implementation Schedule	Responsible Party	Status / Date / Initials
43	The Authorized Biologist(s) and/or Biological Monitor(s) shall maintain a record of all Covered Species handled. This information shall include: (a) the locations (narrative and maps) and dates of observation, including whether the individual(s) was found above ground or in a burrow; (b) ambient temperature when handled and released; (c) general condition and health of the individual(s), including injuries, state of healing, and whether the individual(s) voided its bladders; (d) identified diagnostic markings (i.e., identification numbers or marked marginal scutes); (e) location moved from and location moved to (using GPS technology), including information on any burrow (natural or artificial) utilized; (f) whether any eggs were discovered and relocated; (g) digital photographs of any Covered Species and eggs handled; and (h) results of ongoing monitoring. The Designated Representative(s) shall provide CDFW with the information listed above submitted in the quarterly reports.	ITP Condition #7.13	During Construction on Entire Project	Permittee	
POST-CONSTRUCTION					
44	No later than 45 days after completion of all mitigation measures, Permittee shall provide CDFW with a Final Mitigation Report. The Biological Monitor(s) or Authorized Biologist(s) shall prepare the Final Mitigation Report which shall include, at a minimum: (1) a summary of all Quarterly Compliance Reports and all ASRs; (2) a copy of the table in the MMRP with notes showing when each of the mitigation measures was implemented; (3) all available information about Project-related incidental take of the Covered Species; (4) information about other Project impacts on the Covered Species; (5) beginning and ending dates of Covered Activities; (6) an assessment of the effectiveness of this ITP's Conditions of Approval in minimizing and fully mitigating Project impacts of the taking on Covered Species; (7) recommendations on how mitigation measures might be changed to more effectively minimize take and mitigate the impacts of future projects on the Covered Species; (8) Include geographic information system (GIS) shapefiles in the format specified in Attachment 3; and (9) any other pertinent information.	ITP Condition # 6.10	Post-construction and after completion of mitigation	Permittee	
OPERATIONS AND MAINTANANCE					
45	Approximately 3 years post construction and once vegetation has been allowed to recover to a minimum 50% from baseline site conditions within the solar sites the temporary desert tortoise fencing will be removed. The chain link security fence will be bent upward 6 to 8 inches above the ground and bent upward so that no sharp edges are exposed along the lower fence margin. The fence will remain open during O&M for the duration of the permit. Provide photos of the modified fence design and the 6–8-inch gap described above in your annual report.	ITP Condition # 7.24	Operation and Maintenance	Permittee	
46	If a potential Covered Species burrow (one that shows evidence of current use or was used in the past) is discovered or a Covered Species is found in an "atypical" den (e.g., a pipe or culvert) during the non-active season, a 100-foot buffer shall be established using flagging. If an occupied burrow is discovered during the desert tortoise active season (September-October and April-May), a buffer of at least 250 feet shall be established. Burrows shall be avoided. Buffer zones shall have restricted entry for activities approved by CDFW.	ITP Condition # 7.25	Operation and Maintenance	Permittee	

	Mitigation Measure	Source	Implementation Schedule	Responsible Party	Status / Date / Initials
47	Workers shall inspect for Covered Species under vehicles and equipment every time the vehicles and equipment are moved. If a Covered Species is present, the worker shall wait for the Covered Species to move on its own to a safe location. Alternatively, the Designated Representative, Authorized Biologist, or Biological Monitor shall be contacted to determine if the animal may be safely moved within the conditions of the ITP.	ITP Condition # 7.26	Operation and Maintenance	Permittee	
48	During Project implementation, all workers shall inform the Designated Representative if a Covered Species is seen within the Project Site. All work in the vicinity of the Covered Species, which could injure or kill the animal, shall cease until the Covered Species is moved by the approved Authorized Biologist or it moves from the construction area of its own accord.	ITP Condition # 7.27	Operation and Maintenance	Permittee	
49	Twenty-Four (24) hours prior to the start of Covered Activities the AB or BM shall conduct a survey of the area where maintenance work will occur. If a desert tortoise burrow is found in the work area the Permittee shall follow guidance in 7.25.	ITP Condition # 7.5.3	Operation and Maintenance	Permittee	
50	Permittee shall provide CDFW with an Annual Status Report (ASR) no later than January 31 of every year beginning with issuance of this ITP and continuing until permit termination date or CDFW determines they are no longer necessary. Each ASR shall include, at a minimum: (1) a summary of any siting's of covered species within the site (2) results of biological surveys performed during the year (3) status of any covered species living on site (4) all available information about Project-related incidental take of the Covered Species; and (5) information about other Project impacts on the Covered Species	ITP Condition # 7.29	Operation and Maintenance	Permittee	

Project Name:
LSA Agreement/ITP Number(s):



Department of Fish and Wildlife

CDFW Region 6 Desert Tortoise Biologist Qualification Form

This form requests information about the qualifications of the Desert Tortoise Authorized Biologist and Biological Monitor specified in California Endangered Species Act Incidental Take Permits (ITP) and Lake or Streambed Alteration (LSA) Agreements issued by California Department of Fish and Wildlife (CDFW).

While use of this form is not mandatory, CDFW strongly recommends completing this form as it will ensure the receipt of adequate information and expedite CDFW review of qualifications.

Requesting Approval for: Authorized Biologist (AB) or Biological Monitor (BM) (skills needed are determined by the conditions in the ITP and measures in the LSA)

Date Submitted: _____

Requesting Approval as: Desert Tortoise AB Desert Tortoise BM

SECTION I. BIOLOGIST NAME AND CONTACT INFORMATION:

Name:		Title:	
Company Name & Address:		Phone:	
		Email:	

SECTION II. RELEVANT STATE OR FEDERAL WILDLIFE PERMITS CURRENTLY HOLD, OR HAVE PREVIOUSLY HELD OR WORKED UNDER (Attach A Copy of the Permit and Any Amendments):

Species	State Permit Number	Federal Permit Number	Dates From/To	Permit Holder

SECTION III. EDUCATION:

College/University & Degree Type Related to Natural Resources or Science/Graduation Date:	
College/University & Degree Type Related to Natural Resources or Science/Graduation Date:	
College/University & Degree Type Related to Natural Resources or Science/Graduation Date:	

Project Name:				
LSA Agreement/ITP Number(s):				
Name/Type of Training	Certification Received (Provide Copy)	Dates (From/To) and Hours	Location	Instructor/Sponsor

SECTION V. ITP/LSA REQUIREMENTS (Copy and paste measure(s) from LSA and/or ITP that describe the Authorized Biologist/Biological Monitors necessary qualifications that require CDFW review and approval)

Relevant LSA Agreement Measures or ITP Conditions:	
Relevant LSA Agreement Measures or ITP Conditions:	
Relevant LSA Agreement Measures or ITP Conditions:	
Relevant LSA Agreement Measures or ITP Conditions:	

SECTION VI. SPECIFIC DESERT TORTOISE FIELD EXPERIENCE

Number of <u>hours</u> conducting desert tortoise-related activities.	
How many worker education programs have you presented?	
How many projects/hours have you been on-site monitoring project activities for compliance and to prevent incidental take of desert tortoise?	
Number of <u>miles walked</u> conducting protocol level presence/absence surveys and clearance surveys.	Presence/Absence Surveys: Clearance Surveys:
Number of wild, free-ranging desert tortoises you encountered during <u>protocol level surveys</u> .	< 100 mm carapace length: ≥ 100 mm carapace length:
Check, one for each size, the number of wild, free-ranging desert tortoises you personally <u>handled under direct supervision of an AB</u> .	<100 mm: Zero <input type="checkbox"/> <10 <input type="checkbox"/> 10-25 <input type="checkbox"/> 25-50 <input type="checkbox"/> 50-75 <input type="checkbox"/> 75-100 <input type="checkbox"/> 100-150 <input type="checkbox"/> >150 <input type="checkbox"/> ≥100 mm: Zero <input type="checkbox"/> <10 <input type="checkbox"/> 10-25 <input type="checkbox"/> 25-50 <input type="checkbox"/> 50-75 <input type="checkbox"/> 75-100 <input type="checkbox"/> 100-150 <input type="checkbox"/> >150 <input type="checkbox"/>
Check, one for each size, the number of wild, free-ranging desert tortoises you have personally <u>handled, under no supervision of an AB</u> .	<100 mm: Zero <input type="checkbox"/> <10 <input type="checkbox"/> 10-25 <input type="checkbox"/> 25-50 <input type="checkbox"/> 50-75 <input type="checkbox"/> 75-100 <input type="checkbox"/> 100-150 <input type="checkbox"/> >150 <input type="checkbox"/> ≥100 mm: Zero <input type="checkbox"/> <10 <input type="checkbox"/> 10-25 <input type="checkbox"/> 25-50 <input type="checkbox"/> 50-75 <input type="checkbox"/> 75-100 <input type="checkbox"/> 100-150 <input type="checkbox"/> >150 <input type="checkbox"/>

Project Name:	
LSA Agreement/ITP Number(s):	
Check, one for each size, the number of transmitters or other devices (specify) you have personally <u>attached</u> to wild, free-ranging desert tortoises.	<100 mm: Zero <input type="checkbox"/> <10 <input type="checkbox"/> 10-25 <input type="checkbox"/> 25-50 <input type="checkbox"/> 50-75 <input type="checkbox"/> 75-100 <input type="checkbox"/> 100-150 <input type="checkbox"/> >150 <input type="checkbox"/> ≥100 mm: Zero <input type="checkbox"/> <10 <input type="checkbox"/> 10-25 <input type="checkbox"/> 25-50 <input type="checkbox"/> 50-75 <input type="checkbox"/> 75-100 <input type="checkbox"/> 100-150 <input type="checkbox"/> >150 <input type="checkbox"/>
Check, one for each size, the number of transmitters or other devices (specify) you personally <u>removed</u> from wild, free-ranging desert tortoises.	<100 mm: Zero <input type="checkbox"/> <10 <input type="checkbox"/> 10-25 <input type="checkbox"/> 25-50 <input type="checkbox"/> 50-75 <input type="checkbox"/> 75-100 <input type="checkbox"/> 100-150 <input type="checkbox"/> >150 <input type="checkbox"/> ≥100 mm: Zero <input type="checkbox"/> <10 <input type="checkbox"/> 10-25 <input type="checkbox"/> 25-50 <input type="checkbox"/> 50-75 <input type="checkbox"/> 75-100 <input type="checkbox"/> 100-150 <input type="checkbox"/> >150 <input type="checkbox"/>
Check, one for each size, the number of <u>blood samples</u> that you have personally collected from wild, free-ranging desert tortoises, under direct supervision of an AB.	<100 mm: Zero <input type="checkbox"/> <10 <input type="checkbox"/> 10-25 <input type="checkbox"/> 25-50 <input type="checkbox"/> 50-75 <input type="checkbox"/> 75-100 <input type="checkbox"/> 100-150 <input type="checkbox"/> >150 <input type="checkbox"/> ≥100 mm: Zero <input type="checkbox"/> <10 <input type="checkbox"/> 10-25 <input type="checkbox"/> 25-50 <input type="checkbox"/> 50-75 <input type="checkbox"/> 75-100 <input type="checkbox"/> 100-150 <input type="checkbox"/> >150 <input type="checkbox"/>
Check, one for each size, the number of <u>blood samples</u> that you have personally collected from wild, free-ranging desert tortoises, under no supervision.	<100 mm: Zero <input type="checkbox"/> <10 <input type="checkbox"/> 10-25 <input type="checkbox"/> 25-50 <input type="checkbox"/> 50-75 <input type="checkbox"/> 75-100 <input type="checkbox"/> 100-150 <input type="checkbox"/> >150 <input type="checkbox"/> ≥100 mm: Zero <input type="checkbox"/> <10 <input type="checkbox"/> 10-25 <input type="checkbox"/> 25-50 <input type="checkbox"/> 50-75 <input type="checkbox"/> 75-100 <input type="checkbox"/> 100-150 <input type="checkbox"/> >150 <input type="checkbox"/>
Check how many desert tortoise burrows you have excavated, under direct supervision of an AB.	Zero <input type="checkbox"/> <10 <input type="checkbox"/> 10-25 <input type="checkbox"/> 25-50 <input type="checkbox"/> 50-75 <input type="checkbox"/> 75-100 <input type="checkbox"/> 100-150 <input type="checkbox"/> >150 <input type="checkbox"/>
Check how many desert tortoise burrows you have excavated, under no supervision.	Zero <input type="checkbox"/> <10 <input type="checkbox"/> 10-25 <input type="checkbox"/> 25-50 <input type="checkbox"/> 50-75 <input type="checkbox"/> 75-100 <input type="checkbox"/> 100-150 <input type="checkbox"/> >150 <input type="checkbox"/>
Check how many desert tortoise burrows you have collected and reburied desert tortoise eggs, under direct supervision of an AB. What month(s) did you find and rebury the eggs?	Zero <input type="checkbox"/> <10 <input type="checkbox"/> 10-25 <input type="checkbox"/> 25-50 <input type="checkbox"/> 50-75 <input type="checkbox"/> 75-100 <input type="checkbox"/> 100-150 <input type="checkbox"/> >150 <input type="checkbox"/> Month: _____
Check how many desert tortoise burrows you have collected and reburied desert tortoise eggs), under no supervision. What month(s) did you find and rebury the eggs?	Zero <input type="checkbox"/> <10 <input type="checkbox"/> 10-25 <input type="checkbox"/> 25-50 <input type="checkbox"/> 50-75 <input type="checkbox"/> 75-100 <input type="checkbox"/> 100-150 <input type="checkbox"/> >150 <input type="checkbox"/> Month: _____
How many wild, free-ranging desert tortoises have you conducted health assessments on independently under the supervision of an AB and/or without supervision?	Disinfection/Sanitation Protocols: / Capture/Handling: / Physical Examination: / Biological Sample collection: / Hydration: / Other: /
Check, one for each category, how many biological samples have you prepared for shipment.	Zero <input type="checkbox"/> <10 <input type="checkbox"/> 10-25 <input type="checkbox"/> 25-50 <input type="checkbox"/> 50-75 <input type="checkbox"/> 75-100 <input type="checkbox"/> 100-150 <input type="checkbox"/> >150 <input type="checkbox"/>

Project Name:	
LSA Agreement/ITP Number(s):	
Check, how many artificial burrow(s) for desert tortoise have you constructed and how many artificial burrow(s) have you supervised the construction?	Constructed: Zero <input type="checkbox"/> <10 <input type="checkbox"/> 10-25 <input type="checkbox"/> 25-50 <input type="checkbox"/> 50-75 <input type="checkbox"/> 75-100 <input type="checkbox"/> 100-150 <input type="checkbox"/> >150 <input type="checkbox"/> Supervised Construction: Zero <input type="checkbox"/> <10 <input type="checkbox"/> 10-25 <input type="checkbox"/> 25-50 <input type="checkbox"/> 50-75 <input type="checkbox"/> 75-100 <input type="checkbox"/> 100-150 <input type="checkbox"/> >150 <input type="checkbox"/>
How many temporary holding pens have you constructed? How many temporary holding pens have you supervised the construction?	Constructed: Supervised Construction:
Check how many translocation plans you have implemented as an AB? Check how many translocation plans you have implemented as a BM? Check how many desert tortoise you have personally translocated without supervision as an AB and BM?	Translocation Plans Implemented as Authorized Biologist: Zero <input type="checkbox"/> <10 <input type="checkbox"/> 10-25 <input type="checkbox"/> 25-50 <input type="checkbox"/> 50-75 <input type="checkbox"/> 75-100 <input type="checkbox"/> 100-150 <input type="checkbox"/> >150 <input type="checkbox"/> Translocation Plans Implemented as Biological Monitor: Zero <input type="checkbox"/> <10 <input type="checkbox"/> 10-25 <input type="checkbox"/> 25-50 <input type="checkbox"/> 50-75 <input type="checkbox"/> 75-100 <input type="checkbox"/> 100-150 <input type="checkbox"/> >150 <input type="checkbox"/> Desert tortoise translocated as Authorized Biological: Zero <input type="checkbox"/> <10 <input type="checkbox"/> 10-25 <input type="checkbox"/> 25-50 <input type="checkbox"/> 50-75 <input type="checkbox"/> 75-100 <input type="checkbox"/> 100-150 <input type="checkbox"/> >150 <input type="checkbox"/> Desert tortoise translocated as Biological Monitor: Zero <input type="checkbox"/> <10 <input type="checkbox"/> 10-25 <input type="checkbox"/> 25-50 <input type="checkbox"/> 50-75 <input type="checkbox"/> 75-100 <input type="checkbox"/> 100-150 <input type="checkbox"/> >150 <input type="checkbox"/>
If you have trained an AB or BM please provide one contact for each. Include the person's name, project name, and ITP number.	Authorized Biologist Name/Project Name/ITP #: Biological Monitor Name/Project Name/ITP:

SECTION VII. REFERENCE INFORMATION

This section requests three references that can confirm your qualifications. Include co-workers/biologists that can verify your experience, but do not use supervisors¹ listed in Section VIII.

Name:	Employer/Position	Address/Location:	Phone:	Email:

¹ In order to provide a broader spectrum of references, supervisors both past and present should not be included.

SECTION VIII. DESERT TORTOISE FIELD EXPERIENCE

This section details desert tortoise experience from the most recent and relevant projects. If more space is needed, attach additional pages in the same table format (i.e., copy/paste format).

A. Project 1:			
Project Name & Location (include County):	Worked on Project Start & End Dates:		
ITP or Other Agency Permit Number:	Role(s):		

Project Name:			
LSA Agreement/ITP Number(s):			
Company Name, Project Supervisor Name, Phone, Email:			
Skills Acquired:			
Skills Used:			
B. Project 2:			
Project Name & Location (include County):		Worked on Project Start & End Dates:	
ITP or Other Agency Permit Number:		Role(s):	
Company Name, Project Supervisor Name, Phone, Email:			
Skills Acquired:			
Skills Used:			
C. Project 3:			
Project Name & Location (include County):		Worked on Project Start & End Dates:	
ITP or Other Agency Permit Number:		Role(s):	
Company Name, Project Supervisor Name, Phone, Email:			
Skills Acquired:			
Skills Used:			
D. Project 4:			
Project Name & Location (include County):		Worked on Project Start & End Dates:	
ITP or Other Agency Permit Number:		Role(s):	
Company Name, Project Supervisor Name, Phone, Email:			
Skills Acquired:			
Skills Used:			
E. Project 5:			
Project Name & Location (include County):		Worked on Project Start & End Dates:	
ITP or Other Agency Permit Number:		Role(s):	
Company Name, Project Supervisor Name, Phone, Email:			
Skills Acquired:			

Project Name:			
LSA Agreement/ITP Number(s):			
Skills Used:			
F. Project 6:			
Project Name & Location (include County):		Worked on Project Start & End Dates:	
ITP or Other Agency Permit Number:		Role(s):	
Company Name, Project Supervisor Name, Phone, Email:			
Skills Acquired:			
Skills Used:			
G. Project 7:			
Project Name & Location (include County):		Worked on Project Start & End Dates:	
ITP or Other Agency Permit Number:		Role(s):	
Company Name, Project Supervisor Name, Phone, Email:			
Skills Acquired:			
Skills Used:			
H. Project 8:			
Project Name & Location (include County):		Worked on Project Start & End Dates:	
ITP or Other Agency Permit Number:		Role(s):	
Company Name, Project Supervisor Name, Phone, Email:			
Skills Acquired:			
Skills Used:			
I. Project 9:			
Project Name & Location (include County):		Worked on Project Start & End Dates:	
ITP or Other Agency Permit Number:		Role(s):	
Company Name, Project Supervisor Name, Phone, Email:			
Skills Acquired:			
Skills Used:			

Add Additional Pages for More Experience

Attachment 3

GIS data collection condition for mitigation sites.

Provide CDFW with GIS Shapefiles. Collect data in WGS84 reference coordinate system in decimal degrees (DD). Provide shapefiles of the following information:

Project Information- County project is in, Project Name, Accessors Parcel Number, Lat, Long, acres, and permit number.

HM Land Information – County HM Lands are located in, Accessors Parcel Number, Lat, Long, acres, and name of mitigation package.

GIS data collection condition for translocation sites.

Provide CDFW with GIS Shapefiles. Collect data in WGS84 reference coordinate system in decimal degrees (DD). Provide shapefiles of the following information:

Project Information- County project is in, Project Name, Accessors Parcel Number, Lat, Long, acres, and permit number.

Desert Tortoise Translocation- County recipient site is located, Recipient Site, Recipient Site Accessor Parcel Number, Lat, Long, Acres of recipient site, desert tortoise release location within recipient site, age translocatee, sex of translocatee, date of translocation, and disease test results of each translocatee.

Attachment 4

APPENDIX C

Recommended Specifications for Desert Tortoise Exclusion Fencing and Tortoise Guard

DESERT TORTOISE EXCLUSION FENCE (2005)

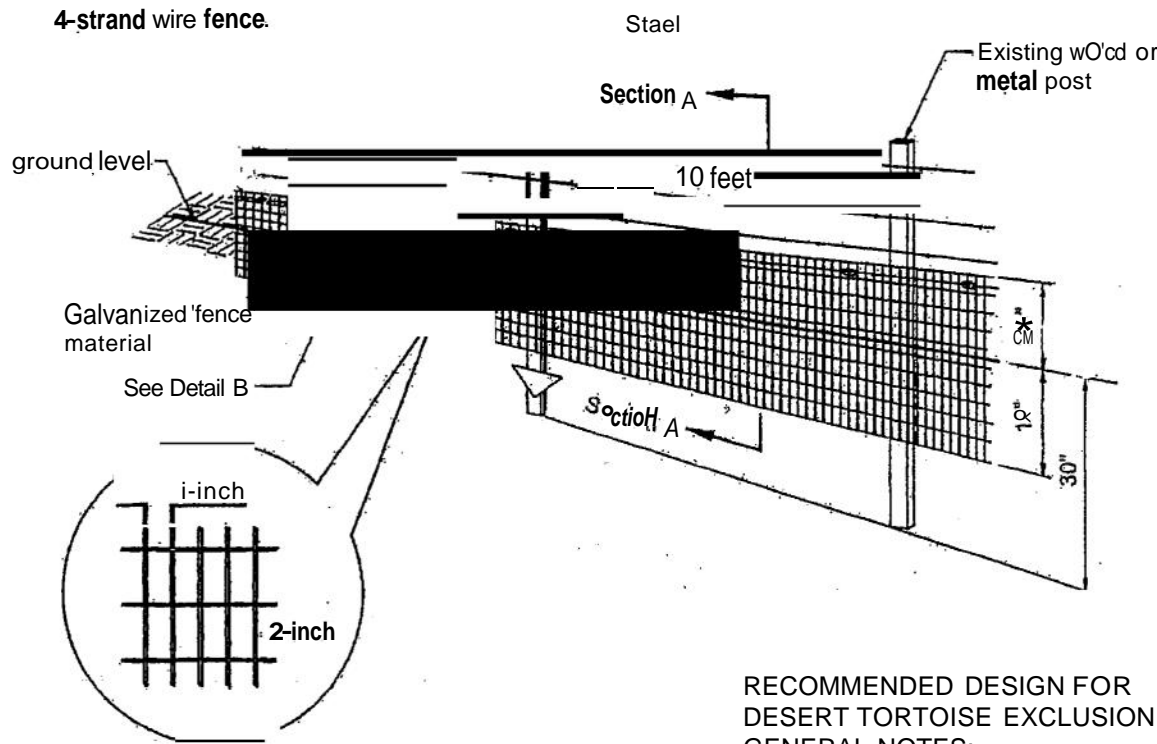

DETAIL A

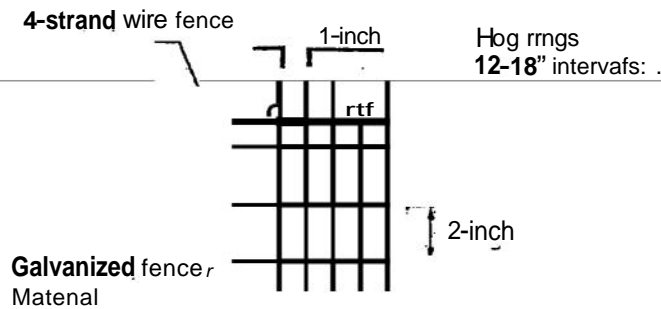

DETAIL B

4-strand wire fence

Hog rings
12-18" intervals
See Detail B

Galvanized fence
Material

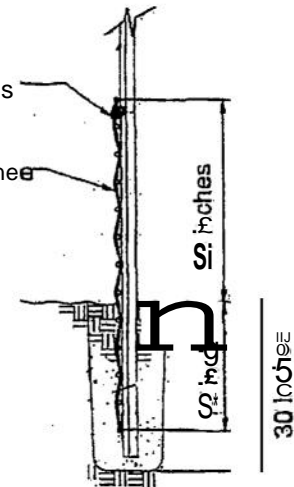

SECTION A

RECOMMENDED DESIGN FOR DESERT TORTOISE EXCLUSION FENCE GENERAL NOTES:

1. Ensure that fence posts and materials conform to the standards approved by the U.S. Fish and Wildlife Service.
2. Ensure that the height above ground level is no less than 18 inches and no higher than 24 inches.
3. Ensure that the depth of fence material below ground level is about 12 inches but no less than 6 inches. (See SECTION A above)
4. Install additional steel posts when distance between existing fence posts exceed 10 feet.
5. Attach fence material to existing fence or wire using hog rings at 12-inch intervals.
6. Fasten fence material to posts with 3 tie wires with a wire near the top, bottom and center of the fence material.
7. Backfill trenches with excavated material and compact the material.
8. Attach fence material to all gates. Ensure that clearance at base of gate achieves zero ground clearance.
9. Substitute smooth wire for barbed wire if additional support wires are necessary.
10. The number and placement of support wires may be modified to allow sheep and deer to pass safely.
11. Erosion at the edge of the fence material where the fence crosses washes may occur and requires appropriate and timely monitoring and repair.
12. Tie the fence into existing culverts and cattleguards when determined necessary to allow desert tortoise passage underneath roadways.

FOR BEDROCK OR CALICHE SUBSTRATE

1. Use this fence design (see below) only for that portion of the fence where fence material cannot be placed 6 inches below existing ground level due to presence of bedrock, large rocks or caliche substrate.
2. Ensure that the fence height above ground level is no less than 22 inches.
3. Ensure that there is a zero to 2-inch ground clearance at the bend.
4. Ensure that the bent portion of the fence is lying on the ground and pointed in the direction of desert tortoise habitat.
5. Cover the portion of the fence that is flush with the ground with cobble (rocks placed on top of the fence material to a vertical thickness up to 4 inches).
6. When substrate no longer is composed of bedrock or caliche, install fence using design shown above.

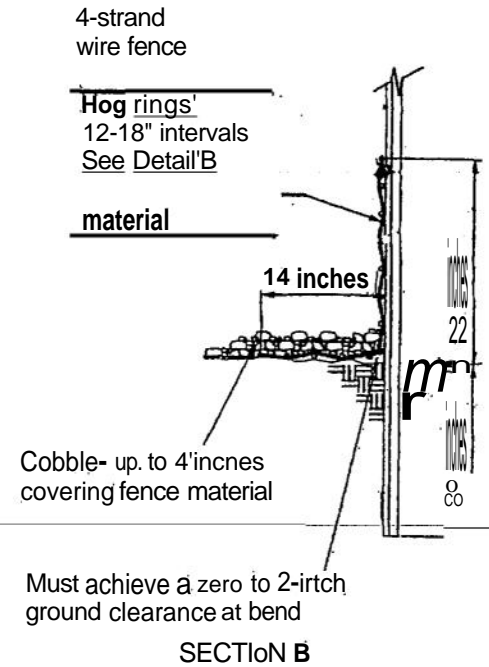
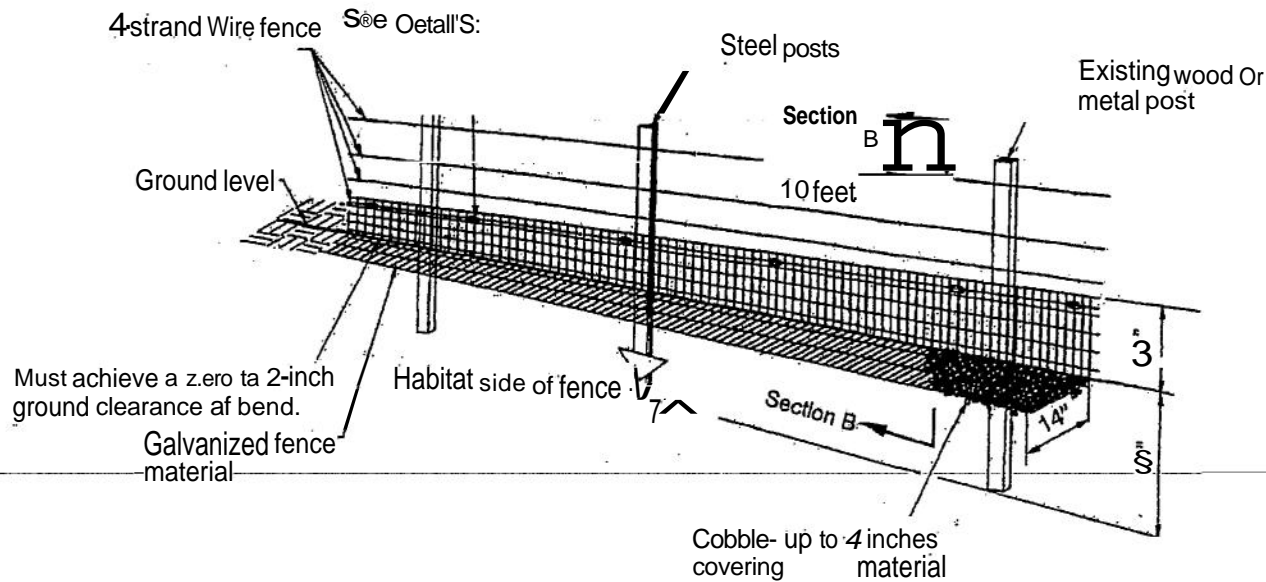

PERMANENT TORTOISE GUARD

CROSS SECTION

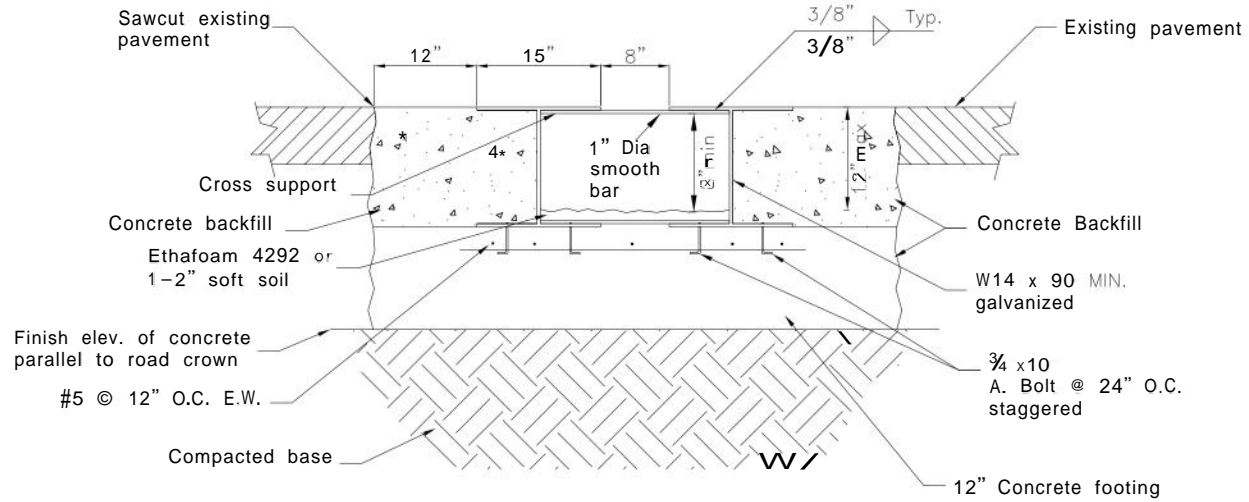

TOP VIEW

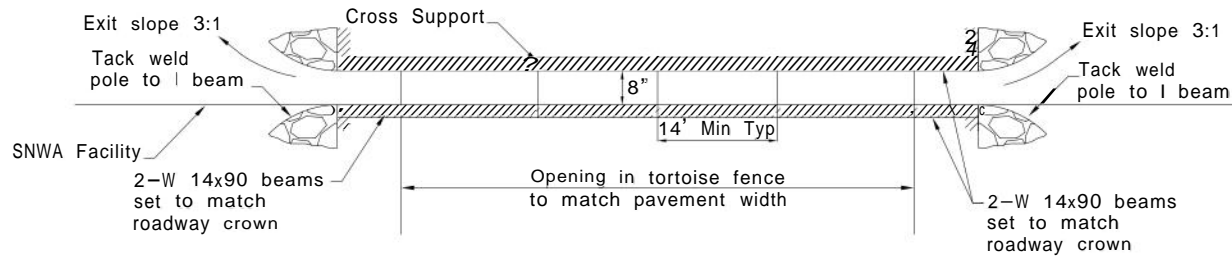

NOTE:
 All metal should be galvanized per spec 05500, paragraph 3.3

RENEWABLE ENERGY ACTION TEAM DEPOSIT DOCUMENT

Detailed instructions for properly completing this document begin on page 7. REAT agencies are responsible for completing this form and submitting it to NFWF when a project proponent will be depositing funds with NFWF, but the deposits identified in the document will be made by the project proponent. Once the deposit document is completed the applicable REAT agency should submit a copy to NFWF and the project proponent. The project proponent should include a copy with the deposit.

Project Name: _____

Project Phase: *(if applicable)* _____

Project Location: *(i.e. County, Township, Range, Section, Base and Meridian)*

Land Ownership of Project Site: *(if publicly owned, identify the applicable government entity)*

Project Proponent: _____

Permittee/Grantee: *(and, if applicable, the parent company)*

Permitting Agency (check if applicable) and Decision Documents:
(identify by name, date, and permit #)

Bureau of Land Management
 Decision Document Attached
Project Identification or Tracking #: _____

California Department of Fish and Wildlife
 Decision Document Attached
Project Identification or Tracking #: _____
 SB 34 Funds

California Energy Commission
 Decision Document Attached
Project Identification or Tracking #: _____

U.S. Fish and Wildlife Service
 Decision Document Attached
Project Identification or Tracking #: _____

Monies Required for Deposit into Sub-Accounts:

Name of Agency Contact Person/Representative	Date
<i>Check the appropriate box(es) below and specify the dollar amount(s) for deposit.</i>	
<input type="checkbox"/> 1. Land Acquisition Deposit RFP Fee (\$30,000) (consult NFWF if needed) NFWF Deposit Fee (\$3,400)	\$ _____ \$ _____ \$ _____
<input type="checkbox"/> 2. Initial Enhancement Deposit NFWF Deposit Fee (\$3,400)	\$ _____ \$ _____
<input type="checkbox"/> 3. Restoration & Habitat Management Deposit NFWF Deposit Fee (\$3,400)	\$ _____ \$ _____
<input type="checkbox"/> 4. Initial & Capital Management & Maintenance Deposit NFWF Deposit Fee (\$3,400)	\$ _____ \$ _____
<input type="checkbox"/> 5. Long-Term Management & Maintenance Deposit NFWF Deposit Fee (\$3,400)	\$ _____ \$ _____
<input type="checkbox"/> 6. Raven Management Deposit	_____
<input type="checkbox"/> 7. Bald & Golden Eagle Deposit	\$ _____
<input type="checkbox"/> 8. Condor Deposit NFWF Deposit Fee	\$ _____ \$ _____
<input type="checkbox"/> 9. Mitigation Effectiveness Monitoring Deposit NFWF Deposit Fee (\$3,400)	\$ _____ \$ _____
TOTAL DEPOSIT for Project (or Project Phase)	\$ _____

Deposit Document Prepared & Submitted by and Date:

Prior Deposit Document(s) submitted for previous deposit(s):
(check and complete, if applicable)

Project Phase: _____	Deposit:	\$ _____
Project Phase: _____	Deposit:	\$ _____
Project Phase: _____	Deposit:	\$ _____

Sub-Account and Required Mitigation Activities¹:

Check the appropriate box below of the Sub-Account that is to receive monies and provide the required information in the numbered sub-sections that follow. If more than one Sub-Account is to receive monies, for each additional Sub-Account check multiple boxes and provide the required information.

1. Land Acquisition Sub-Account

- a. Description of Mitigation Activity (including acreage totals):
- b. Citation (e.g., page, section, condition number) to Applicable Decision Document(s) *(these documents must be provided to NFWF at time of submission of Deposit Document):*
- c. Implementation Schedule (including determination of start date, performance period, and due date and determination method for satisfaction of the required Mitigation Activity):
- d. Applicable REAT Agency(ies) with Authority over Implementation of the Mitigation Activity and Contact Information:

2. Initial Enhancement Sub-Account

- a. Description of Mitigation Activity (including acreage totals):
- b. Citation (e.g., page, section, condition number) to Applicable Decision Document(s) *(these documents must be provided to NFWF at time of submission of Deposit Document):*
- c. Implementation Schedule (including determination of start date, performance period, and due date and determination method for satisfaction of the required Mitigation Activity):
- d. Applicable REAT Agency(ies) with Authority over Implementation of the Mitigation Activity and Contact Information:

3. Restoration & Habitat Management Sub-Account

- a. Description of Mitigation Activity (including acreage totals):
- b. Citation (e.g., page, section, condition number) to Applicable Decision Document(s) *(these documents must be provided to NFWF at time of submission of Deposit Document):*

¹ The term "Mitigation Activities" for purposes of this Deposit Document means "any biological mitigation or conservation actions required as conditions of Project approval, and other actions agreed to by the Proponent in the Project description, as identified in a Decision Document. Mitigation Activities include, but may not be limited to, the acquisition, protection, and long-term management of compensatory habitat; the restoration, enhancement, or protection of other habitat; actions to protect or manage sensitive species; related monitoring and reporting; and other associated actions, including but not limited to land appraisals and inspections, title searches, and special studies."

- c. Implementation Schedule (including determination of start date, performance period, and due date and determination method for satisfaction of the required Mitigation Activity):
- d. Applicable REAT Agency(ies) with Authority over Implementation of the Mitigation Activity and Contact Information:

4. Initial & Capital Management & Maintenance Sub-Account

- a. Description of Mitigation Activity (including acreage totals):
- b. Citation (e.g., page, section, condition number) to Applicable Decision Document(s) *(these documents must be provided to NFWF at time of submission of Deposit Document):*
- c. Implementation Schedule (including determination of start date, performance period, and due date and determination method for satisfaction of the required Mitigation Activity):
- d. Applicable REAT Agency(ies) with Authority over Implementation of the Mitigation Activity and Contact Information:

5. Long-Term Management & Maintenance Sub-Account

- a. Description of Mitigation Activity (including acreage totals):
- b. Citation (e.g., page, section, condition number) to Applicable Decision Document(s) *(these documents must be provided to NFWF at time of submission of Deposit Document):*
- c. Implementation Schedule (including determination of start date, performance period, and due date and determination method for satisfaction of the required Mitigation Activity):
- d. Applicable REAT Agency(ies) with Authority over Implementation of the Mitigation Activity and Contact Information:

6. Raven Management Sub-Account

- a. Description of Mitigation Activity (including acreage totals):
- b. Citation (e.g., page, section, condition number) to Applicable Decision Document(s) *(these documents must be provided to NFWF at time of submission of Deposit Document):*

- c. Implementation Schedule (including determination of start date, performance period, and due date and determination method for satisfaction of the required Mitigation Activity):

Applicable REAT Agency(ies) with Authority over Implementation of the Mitigation Activity and Contact Information: *CDFW*

- d.

7. Bald & Golden Eagle Sub-Account

- a. Description of Mitigation Activity (including acreage totals):
- b. Citation (e.g., page, section, condition number) to Applicable Decision Document(s) *(these documents must be provided to NFWF at time of submission of Deposit Document):*
- c. Implementation Schedule (including determination of start date, performance period, and due date and determination method for satisfaction of the required Mitigation Activity):
- d. Applicable REAT Agency(ies) with Authority over Implementation of the Mitigation Activity and Contact Information:

8. Condor Sub-Account

- a. Description of Mitigation Activity (including acreage totals):
- b. Citation (e.g., page, section, condition number) to Applicable Decision Document(s) *(these documents must be provided to NFWF at time of submission of Deposit Document):*
- c. Implementation Schedule (including determination of start date, performance period, and due date and determination method for satisfaction of the required Mitigation Activity):
- d. Applicable REAT Agency(ies) with Authority over Implementation of the Mitigation Activity and Contact Information:

9. Mitigation Effectiveness Monitoring Sub-Account

Insert information about the "NFWF Annual Fee" and "Investment Policy Statement" below after discussing these items with NFWF in advance.

NFWF Annual Fee:

Investment Policy Statement:

- a. Description of Mitigation Activity (including acreage totals):

-
- b. Citation (e.g., page, section, condition number) to Applicable Decision Document(s)
(these documents must be provided to NFWF at time of submission of Deposit Document):
 - c. Implementation Schedule (including determination of start date, performance period, and due date and determination method for satisfaction of the required Mitigation Activity):
 - d. Applicable REAT Agency(ies) with Authority over Implementation of the Mitigation Activity and Contact Information:

DEPOSIT DOCUMENT INFORMATION & INSTRUCTIONS

The Deposit Document is for use by the Renewable Energy Action Team Agencies (USFWS, BLM, DFW, and CEC) and the National Fish and Wildlife Foundation (NFWF). The Deposit Document is not itself a Decision Document. The Deposit Document is to be filled out by the appropriate REAT Agency(ies) staff, as determined by the REAT Agencies. The REAT Agency staff who takes the lead in preparing the Deposit Document shall coordinate with the other applicable REAT Agency staff, non-REAT Agency staff if the lead permitting agency is not a REAT Agency, and NFWF staff prior to finalizing the Deposit Document. REAT agencies are responsible for completing this form and submitting it to NFWF when a project proponent will be depositing funds with NFWF, but the deposits identified in the document will be made by the project proponent. Once the deposit document is completed the applicable REAT agency should submit a copy to NFWF and the project proponent. The project proponent should include a copy with the project proponent's deposit.

The REAT Agency to take the lead in preparing the Deposit Document shall be as follows:

- The CEC if the CEC is a permitting agency regardless of whether the project is on public or private lands
- The BLM if the CEC is not a permitting agency and the project is on public lands
- The DFW if the CEC is not a permitting agency, the project is on private lands, and the DFW issues a permit under Fish and Wildlife Code section 2081(b)
- The USFWS if the CEC is not a permitting agency, the project is on private lands, and the DFW makes a consistency determination under Fish and Wildlife Code section 2080.1

A. Project Name:

- Identify the name of the permitted project.

B. Project Phase:

- If the project has been permitted in phases, specify the phase(s) to which this Deposit Document applies.

C. Project Location:

- Identify the county in which the project is located.
- Provide available information as to township, range, section, and base and meridian.

D. Land Ownership of Project Site:

- Indicate whether the land on which the permitted project or project phase(s) is located is privately or publicly owned.
- If it is publicly owned, identify the applicable governmental entity.

E. Permittee/Grantee:

- Identify the name of the permittee/grantee, which also may be known as the project proponent or responsible party.
- If the permittee/grantee is a company that is owned by another company, identify the name of the parent company.

F. Permitting Agency and Decision Documents:

- Check the box of each permitting agency. This is an agency that has issued a decision document (permit or other authorization) for the project or project phase(s).
- Under the applicable permitting agency, identify the decision document by (1) name; (2) date; (3) permit identification number.
- Submit with the Deposit Document, a CD or hard copy of each decision document, and indicate by checking the box that the decision document is attached.
- Under the applicable permitting agency, identify the project identification or tracking number. For example, for BLM, this is the “CACA” number. For DFW, this may be an “ITP”, “SAA”, “SCH”, or other number. For the CEC, this is the “Decision” number. For the USFWS, this is the “Permit” or “File” number. For DFW, if any funds collected by DFW pursuant to SB 34 are being deposited, check the box indicating this fact and specify in the “Required Measure Details” of the deposit document which of the measures are to be paid for using such funds.

G. Monies Required for Deposit:

- There are the following potential new and already established Sub-Accounts for each Project established under the NFWF REAT Mitigation Account. For each new Sub-Account there is a one-time \$3400 Deposit Fee, and an Annual Fee. The Sub-Accounts and the associated NFWF fees to be paid by the project proponent are as follows:
 1. Land Acquisition Sub-Account
 - a. NFWF Deposit Fee (\$3400 one-time)
 - b. NFWF Annual Fee (greater of 3% or \$1000 annual)
 2. Initial Enhancement Sub-Account
 - a. NFWF Deposit Fee (\$3400 one-time)
 - b. NFWF Annual Fee (greater of 3% or \$1000 annual)
 3. Restoration & Habitat Management Sub-Account
 - a. NFWF Deposit Fee (\$3400 one-time)
 - b. NFWF Annual Fee (greater of 3% or \$1000 annual)
 4. Long-Term Management & Maintenance Sub-Account
 - a. NFWF Deposit Fee (\$3400 one-time)
 - b. NFWF Annual Fee (1%)
 5. Initial & Capital Management & Maintenance Sub-Account
 - a. NFWF Deposit Fee (\$3400 one-time)
 - b. NFWF Annual Fee (greater of 1% or \$1000 annual)
 6. Raven Management Sub-Account
 - a. NFWF Deposit Fee (already established and paid by the initial depositor)
 - b. NFWF Annual Fee (greater of 2% or \$1000 annual)
 7. Bald & Golden Eagle Sub-Account
 - a. NFWF Deposit Fee (already established and paid by the initial depositor)
 - b. NFWF Annual Fee (greater of 2% or \$1000 annual)
 8. Condor Sub-Account
 - a. NFWF Deposit Fee (already established and paid by the initial depositor)
 - b. NFWF Annual Fee (greater of 2% or \$1000 annual)
 9. Mitigation Effectiveness Monitoring Sub-Account
 - a. NFWF Deposit Fee (\$3400 one-time)
 - b. NFWF Annual Fee (to be determined on a sub-account specific basis and set forth in Section 9 of Sub-Account and Required Mitigation Activities of the Deposit Document)

- Check the box next to each Sub-Account that is to receive monies for required measures for the permitted project or project phase(s).
- See Section J below for instructions on entering dollar amounts for the applicable Sub-Account.
- To calculate the “**TOTAL DEPOSIT for Project (or Project Phase),**” add together all of the amounts indicated in the spaces provided to be deposited into each of the sub-accounts for the required Mitigation Activities cost estimates.

- Please note that all costs are best estimates. In addition, with respect to any Mitigation Activities, including Land Acquisition Mitigation Activities, that are based on the REAT Cost Table, the costs are the REAT’s best estimates as of July 23, 2010. Actual costs will be determined at the time of the transactions and may change the funding needed to implement the required Mitigation Activities. Regardless of the estimates, the Project proponent is responsible for providing adequate funding to implement the required Mitigation Activities.

H. Deposit Document Prepared & Submitted by and Date:

- The REAT Agency staff who takes the lead in preparing the Deposit Document shall identify his/her name, contact information, and Agency, and date. This information is helpful for NFWF staff if there are questions about the Deposit Document.

I. Prior Deposit Documents:

- Check the box if a prior deposit document was submitted for the project. If the box is checked, identify the phase of the project and the total dollar figure of the deposit for which the prior deposit document was submitted. There is space to identify up to five (5) prior deposit documents.

J. Specific Sub-Account Information

1. Land Acquisition Sub-Account:

- a. A Land Acquisition Sub-Account is for land acquisitions for compensatory mitigation.
- b. The amount of money to be deposited for the Land Acquisition Sub-Account can be found in the “Total – Land Acquisition” line-item on the applicable REAT Cost Table. This amount includes the estimated cost of all land acquisition measures (which may involve multiple habitat types), the NFWF Annual Management Fee, the NFWF Deposit Fee for the Land Acquisition Sub-Account establishment). The applicable REAT Agencies may also indicate an RFP fee when they anticipate the need for an RFP associated with a Mitigation Activity.
- c. All NFWF fees for the Land Acquisition Sub-Account are calculated per sub-account, not per habitat type.
- d. NFWF’s prevailing Investment Policy Statement Governing Cash Management governs the investment of funds in this sub-account.
- e. In the “**Monies Required for Deposit into Sub-Accounts**” section of the Deposit Document:
 - In the space provided for the Land Acquisition Deposit line-item, specify the amount of money to be deposited into the Land Acquisition Sub-Account for the land acquisition, including the NFWF Annual Management Fee.
 - In the space provided for the RFP Fee line-item, if the applicable REAT Agencies indicate the need for an RFP associated with the land acquisition and the depositor is

including the RFP Fee in its deposit, specify the amount of money to be deposited into the Land Acquisition Sub-Account for the anticipated RFP.

- In the space provided for the NFWF Deposit Fee line-item, specify the amount of money to be deposited into the Land Acquisition Sub-Account for the NFWF Deposit Fee to establish the sub-account.

2. Initial Enhancement Sub-Account:

- a. An Initial Enhancement Sub-Account is for initial actions to enhance the habitat on the acquired compensatory mitigation lands.
- b. The amount of money to be deposited for the Initial Enhancement Sub-Account can be found in the “Total – Initial Enhancement” line-item on the applicable REAT Cost Table. This amount includes the estimated cost of initial enhancement measures, the NFWF Annual Management Fee, and the NFWF Deposit Fee for the Initial Enhancement Sub-Account establishment.
- c. All NFWF fees for the Initial Enhancement Sub-Account are calculated per sub-account.
- d. NFWF’s prevailing Investment Policy Statement Governing Cash Management governs the investment of funds in this sub-account.
- e. In the “**Monies Required for Deposit into Sub-Accounts**” section of the Deposit Document:
 - In the space provided for the Initial Enhancement Deposit line-item, specify the amount of money to be deposited into the Initial Enhancement Sub-Account for initial enhancement activities, including the NFWF Annual Management Fee.
 - In the space provided for the NFWF Deposit Fee line-item, specify the amount of money to be deposited into the Initial Enhancement Sub-Account for the NFWF Deposit Fee to establish the sub-account.

3. Restoration & Habitat Management Sub-Account:

- a. A Restoration & Habitat Management Sub-Account is for actions to mitigate impacts by restoring and/or managing habitats on existing public or private lands, or on acquired compensatory mitigation lands.
- b. The amount of money to be deposited for the Restoration & Habitat Management Sub-Account can be found in the “Total – Restoration & Habitat Management” line-item on the applicable REAT Cost Table. This amount includes the estimated cost of restoration and habitat management measures, the NFWF Annual Management Fee, and the NFWF Deposit Fee for the Restoration & Habitat Management Sub-Account establishment.
- c. All NFWF fees for the Restoration & Habitat Management Sub-Account are calculated per sub-account.
- d. NFWF’s prevailing Investment Policy Statement Governing Cash Management governs the investment of funds in this sub-account.
- e. In the “**Monies Required for Deposit into Sub-Accounts**” section of the Deposit Document:
 - In the space provided for the Restoration & Habitat Management Deposit line-item, specify the amount of money to be deposited into the Restoration & Habitat Management Sub-Account for restoration and habitat management activities, including the NFWF Annual Management Fee.
 - In the space provided for the NFWF Deposit Fee line-item, specify the amount of money to be deposited into the Restoration & Habitat Management Sub-Account for the NFWF Deposit Fee to establish the sub-account.

4. Initial & Capital Management & Maintenance Sub-Account:

- a. An Initial & Capital Management & Maintenance Sub-Account is for actions required to manage and maintain lands acquired for compensatory mitigation in the first three years or other initial period of management and maintenance.
- b. The amount of money to be deposited for the Initial & Capital Management & Maintenance Sub-Account can be found in the “Total – Initial & Capital Management & Maintenance” line-item on the applicable REAT Cost Table. This amount includes the estimated cost of initial and capital management and maintenance measures, the NFWF Annual Management Fee, and the NFWF Deposit Fee for the Initial & Capital Management & Maintenance Sub-Account establishment.
- c. All NFWF fees for the Initial & Capital Management & Maintenance Sub-Account are calculated per sub-account.
- d. NFWF’s prevailing Investment Policy Statement Governing Cash Management governs the investment of funds in this sub-account.
- e. In the “**Monies Required for Deposit into Sub-Accounts**” section of the Deposit Document:
 - o In the space provided for the Initial & Capital Management & Maintenance Deposit line-item, specify the amount of money to be deposited into the Initial & Capital Management & Maintenance Sub-Account for initial and capital management and maintenance activities, including the NFWF Annual Management Fee.
 - o In the space provided for the NFWF Deposit Fee line-item, specify the amount of money to be deposited into the Initial & Capital Management & Maintenance Sub-Account for the NFWF Deposit Fee to establish the sub-account.

5. Long-Term Management & Maintenance Sub-Account:

- a. A Long-Term Management & Maintenance Sub-Account is for actions required for the long-term management and maintenance of lands acquired for compensatory mitigation following the initial period of management and maintenance.
- b. If the project is at the initial stage where the developer is securing the performance of the requirement to set aside funds for the long-term management and maintenance of compensatory mitigation lands that have yet to be acquired, then the dollar figure in the “Total – Long-Term Management & Maintenance” line-item on the applicable REAT Cost Table represents the amount of the security for performance to be deposited or placed with the applicable REAT Agencies. This amount is an estimate based on a formula specified by the REAT Agencies.
 - i. The space provided for the Long-Term Management & Maintenance line-item on the Deposit Document should be left blank because the security for performance is not deposited with NFWF.
- f. If the project is at the phase where the compensatory mitigation lands have been approved by the applicable REAT Agencies for acquisition or CE protection, and 1) the amount of money required to be set aside for the long-term management and maintenance of the mitigation lands has been calculated and approved by the applicable REAT Agencies in accordance with a Property Record Analysis (PAR) or other property analysis methodology; and 2) NFWF is to be the holder of the Long-Term Management & Maintenance funds, then in the “**Monies Required for Deposit into Sub-Accounts**” section of the Deposit Document:

- ii. In the space provided for the Long-Term Management & Maintenance Deposit line-item, specify the amount of money to be deposited into the Long-Term Management & Maintenance Sub-Account for the long-term management and maintenance of the compensatory mitigation lands. This should be the amount identified in the PAR or other property analysis methodology for long-term management and maintenance activities (which incorporates into its calculation the NFWF Annual Management Fee).
- iii. In the space provided for the NFWF Deposit Fee line-item, specify the amount of money to be deposited into the Long-Term Management & Maintenance Sub-Account for the NFWF Deposit Fee to establish the sub-account.
- c. All NFWF fees for the Long-Term Management & Maintenance Sub-Account are calculated per sub-account.
- d. The REAT’s prevailing Investment Policy Statement for Mitigation Endowment Accounts Held by the National Fish and Wildlife Foundation (As of July 2018) governs the investment of funds in this sub-account.
- e. Other special provisions as set forth below on pages 16-17 apply to this sub-account.

6. Raven Management Sub-Account:

- a. The Raven Management Sub-Account is a single comingled sub-account for actions to manage ravens in order to minimize and mitigate impacts to desert tortoise, as identified by the Raven Management Work Group and approved by the REAT Agency Managers following the elements outlined in Mitigation for Common Raven Predation on the Desert Tortoise (http://dmg.gov/documents/20101130_RPT_Common_Raven_Predation_on_DT_USFW_S.pdf) and analyzed in the Environmental Assessment to Implement a Desert Tortoise Recovery Plan Task: Reduce Common Raven Predation on the Desert Tortoise (USFWS et. al 2008).
- b. The amount of money to be deposited into the Raven Management Sub-Account is the estimated cost of raven management measures, as determined by the applicable REAT Agencies, including the NFWF Annual Management Fee, and, if applicable, the NFWF Deposit Fee for the Raven Management Sub-Account establishment.
- c. NFWF’s prevailing Investment Policy Statement Governing Cash Management governs the investment of funds in this sub-account.
- d. In the “**Monies Required for Deposit into Sub-Accounts**” section of the Deposit Document:
 - o In the space provided for the Raven Management Deposit line-item, specify the amount of money to be deposited into the Raven Management Sub-Account for raven management activities, including the NFWF Annual Management Fee.

7. Bald & Golden Eagle Sub-Account:

- a. The Bald & Golden Eagle Sub-Account is a single, comingled sub-account actions to conserve bald and golden eagles and minimize impacts from development.
- b. The amount of money to be deposited into the Bald & Golden Eagle Account is the estimated cost of bald and golden eagle Mitigation Activities, as determined by the applicable REAT Agencies, including the NFWF Annual Management Fee, and if applicable, the NFWF Deposit Fee for Bald & Golden Eagle Sub-Account establishment.
- c. NFWF’s prevailing Investment Policy Statement Governing Cash Management governs the investment of funds in this sub-account.

- d. In the **“Monies Required for Deposit into Sub-Accounts”** section of the Deposit Document:
 - o In the space provided for the Bald & Golden Eagle Deposit line-item, specify the amount of money to be deposited into the Bald & Golden Eagle Sub-Account for bald and golden eagle activities, including the NFWF Annual Management Fee.

8. Condor Sub-Account:

- a. The Condor Sub-Account is a single, comingled sub-account for actions to conserve and manage condors.
- b. The amount of money to be deposited into the Condor Sub-Account is the estimated cost of Condor Activities, as determined by the applicable REAT Agencies, including the NFWF Annual Management Fee, and if applicable, the NFWF Deposit Fee for the Condor Sub-Account establishment.
- c. NFWF’s prevailing Investment Policy Statement Governing Cash Management governs the investment of funds in this sub-account.
- d. In the **“Monies Required for Deposit into Sub-Accounts”** section of the Deposit Document:
 - o In the space provided for the Condor Deposit line-item, specify the amount of money to be deposited into the Condor Sub-Account for condor activities, including the NFWF Annual Management Fee.
 - o As to the initial deposit, in the space provided for the NFWF Deposit Fee line-item on the Deposit Document, specify the amount of money to be deposited into the Condor Sub-Account for the NFWF Deposit Fee to establish the sub-account.

9. Mitigation Effectiveness Monitoring Sub-Account:

- a. The Mitigation Effectiveness Monitoring Sub-Account is for identified mitigation effectiveness monitoring, as specified by the applicable REAT Agencies.
- b. The amount of money to be deposited into the Mitigation Effectiveness Monitoring Sub-Account is the estimated cost of Mitigation Effectiveness Monitoring Activities, as determined by the applicable REAT Agencies, including the NFWF Annual Management Fee, and if applicable, the NFWF Deposit Fee for the Mitigation Effectiveness Monitoring Sub-Account establishment.
- c. All NFWF fees for the Mitigation Effectiveness Monitoring Sub-Account are calculated per sub-account. The NFWF Annual Management Fee for this sub-account is to be determined on a sub-account specific basis and set forth in Section 9 of Sub-Account and Required Mitigation Activities of the Deposit Document.
- d. The applicable prevailing NFWF Investment Policy Statement to govern the investment of funds in this sub-account is to be determined on a sub-account specific basis and set forth in Section 9 of Sub-Account and Required Mitigation Activities of the Deposit Document.
- e. In the **“Monies Required for Deposit into Sub-Accounts”** section of the Deposit Document:
 - o In the space provided for the Mitigation Effectiveness Monitoring Deposit line-item, specify the amount of money to be deposited into the Initial Enhancement Sub-Account for mitigation effectiveness monitoring activities, including the NFWF Annual Management Fee.

- In the space provided for the NFWF Deposit Fee line-item, specify the amount of money to be deposited into the Mitigation Effectiveness Monitoring Sub-Account for the NFWF Deposit Fee to establish the sub-account.

K. Sub-Account and Required Mitigation Activities² Details:

- The following are the Mitigation Activities by Sub-Account:
 1. **Land Acquisition:** These are land acquisitions for compensatory mitigation.
 2. **Initial Enhancement:** These are initial actions to enhance the habitat on the acquired compensatory mitigation lands.
 3. **Restoration & Habitat Management:** These are actions to mitigate impacts by restoring and/or managing habitats on existing public or private lands, or on acquired compensatory mitigation lands.
 4. **Initial & Capital Management & Maintenance:** These are actions required to manage and maintain lands acquired for compensatory mitigation in the first three years or other initial period of management and maintenance.
 5. **Long-term Management & Maintenance:** These are actions required for the long-term management and maintenance of lands acquired for compensatory mitigation following the initial period of management and maintenance.
 6. **Raven Management:** These are actions to manage ravens in order to minimize and mitigate impacts to desert tortoise, as identified by the Raven Management Work Group and approved by the REAT Agency Managers following the elements outlined in Mitigation for Common Raven Predation on the Desert Tortoise (http://dmg.gov/documents/20101130_RPT_Common_Raven_Predation_on_DT_USFW_S.pdf) and analyzed in the Environmental Assessment to Implement a Desert Tortoise Recovery Plan Task: Reduce Common Raven Predation on the Desert Tortoise (USFWS et. al 2008).
 7. **Bald & Golden Eagle:** These are actions to conserve bald and golden eagles and minimize impacts from development.
 8. **Condor:** These are actions to conserve and manage condors.
 9. **Mitigation Effectiveness Monitoring:** These are actions for identified mitigation effectiveness monitoring, as specified by the applicable REAT Agencies.

- Make a list of the required Mitigation Activities to be funded with monies deposited into the applicable Sub-Account.

- For each Mitigation Activity, please provide the specific information in subsections a-d, as follows:
 - Subsection a.: Description of the Mitigation Activity
 - Subsection b.: Citation(s) to the applicable Decision Document(s) requiring the Mitigation Activity, such as the page, section, and condition number. Please provide copies of the Decision Document(s) to NFWF at the time of submission of the Deposit Document.
 - Subsection c: Determination of the start date, performance period, and due date and determination method for satisfaction of Mitigation Activity
 - Subsection d.: Identification of the applicable REAT Agency(ies) with authority over implementation of the Mitigation Activity, the name of the agency contact

² See Footnote 1 for the definition of the term “Mitigation Activities.”

- person/representative for the sub-account, and the contact information for the such person, including phone number and email address.
- For DFW, indicate which Mitigation Activity, if any, are to be paid for using deposited SB 34 funds, the use of which is limited to mitigation.

SPECIAL PROVISIONS FOR LONG-TERM MANAGEMENT & MAINTENANCE SUB-ACCOUNTS

The REAT Agencies and NFWF have agreed to the following provisions and procedures for Long-Term Management & Maintenance Sub-Accounts established within the REAT Account. To the extent these provisions and procedures pertain to disbursements of monies from such sub-accounts, such provisions and procedures will be included in Recipient Agreements that NFWF signs with entities or individuals that receive monies from Long-Term Management & Maintenance Sub-Accounts (Recipients).

- A. The applicable REAT Agency(ies) are responsible for approving the Property Analysis Record, or equivalent endowment assessment methodology (in either case the “Endowment Assessment”) that calculates the amount of money necessary to provide a source of long-term or perpetual funding for the long-term management and maintenance of the applicable compensatory mitigation lands required by or incorporated as agreed to in the applicable Decision Document(s), and shall approve an associated payment schedule for disbursements from a Long-Term Management & Maintenance Sub-Account.
- B. The REAT Agencies may elect to meet with NFWF at intervals as requested by the REAT Agencies (but no more frequently than annually) to review, in consultation with NFWF’s investment advisors, the financial status of any Long-Term Management & Maintenance Sub-Accounts for the purpose of assessing whether actual investment performance to date, prevailing economic conditions, or other factors pose a material risk of depletion with respect to such Long-Term Management & Maintenance Sub-Accounts. If NFWF and the applicable REAT Agencies determine, in consultation with NFWF’s investment advisors, that there exists a material risk of depletion with respect to any Long-Term Management & Maintenance Sub-Accounts, NFWF and the applicable REAT Agencies will jointly develop one or more options that may be employed by the applicable REAT Agency(ies) to mitigate such risk. Options include, but are not necessarily limited to, a determination and directive by the applicable REAT Agency(ies) to suspend or reduce disbursements from one or more Long-Term Management & Maintenance Sub-Accounts for a period of time until the risk of depletion has receded to acceptable levels. The determination to implement any such risk mitigation options shall be made by the applicable REAT Agency(ies) acting in their sole discretion, in writing, to NFWF. To the greatest extent feasible, the applicable REAT Agency(ies) will exercise their discretion in a manner that does not adversely affect the ability to achieve the biological minimization and mitigation objectives under the applicable REAT Agency’s(ies’) respective Decision Documents. NFWF will implement risk mitigation options as directed in writing by the applicable REAT Agency(ies).
- C. To the extent authorized by applicable Decision Documents, law or regulation, the applicable REAT Agency(ies) may suspend or reduce disbursements from a Long-Term Management & Maintenance Sub-Account for reasons related to the Recipient’s performance of long-term land management and maintenance activities on the applicable compensatory mitigation lands. In the event any applicable REAT Agency exercises such authority, it will provide written notice and direction to NFWF to suspend or reduce disbursements. NFWF will suspend or reduce disbursements from a Long-Term Management & Maintenance Sub-Account as directed by the applicable REAT Agency(ies) in writing.

- D. To the extent authorized by applicable Decision Documents, law or regulation, the applicable REAT Agency(ies) may authorize or direct NFWF in writing to make disbursements from a Long-Term Management & Maintenance Sub-Account to fund a project or activity that was not accounted for in the applicable Endowment Assessment, including but not necessarily limited to activities in response to a catastrophic event, e.g., recovery after a fire. NFWF will make such disbursements, as directed by the applicable REAT Agency(ies) in writing. The applicable REAT Agency(ies) acknowledge that such disbursements may impair the viability of the applicable Long-Term Management & Maintenance Sub-Account as a source of perpetual funding for long-term management and maintenance activities for the applicable compensatory mitigation lands.
- E. NFWF shall not be liable in any respect to the REAT Agencies or any Recipient, or to any other person or entity, for:
1. any errors, omissions, inaccuracies, or other elements of any Endowment Assessment approved by the applicable REAT Agency(ies) for compensatory mitigation lands required by or incorporated into a Decision Document;
 2. any decision, direction, or instruction by the applicable REAT Agency(ies) that suspends or reduces disbursements of funding from any Long-Term Management & Maintenance Sub-Account; or
 3. any decision, direction, or instruction by the applicable REAT Agency(ies) that directly or indirectly impairs the viability of any Long-Term Management & Maintenance Sub-Account as a source of perpetual funding for the long-term management and maintenance activities for the applicable compensatory mitigation lands.

SUBMITTING THE DEPOSIT DOCUMENT AND FUNDS FOR DEPOSIT

The Deposit Document may be submitted to NFWF by a REAT Agency separately from, but concurrent with, the Project Proponent's payment of funds for deposit, or the Deposit Document may be submitted to NFWF by the Project Proponent together with the payment of funds for deposit. The funds for deposit may be paid by check or wire:

All deposits must include a notation identifying the name of the project for which the deposit is being made.

Deposits by check shall be sent to:

National Fish and Wildlife Foundation
1133 15th Street, NW, Suite 1000
Washington, D.C. 20005
Attn: Chief Financial Officer

Deposits by wire shall be sent to:

For depositors desiring to send funds to NFWF via electronic funds transfer, the deposit will be made in accordance with wire instructions provided by NFWF in writing at the time of deposit.

[Financial institution letterhead]

IRREVOCABLE STANDBY LETTER OF CREDIT
NO. **[number issued by financial institution]**

Issue Date: **[date]**

Beneficiary:

California Department of Fish and Wildlife
Habitat Conservation Planning Branch
Post Office Box 944209
Sacramento, CA 94244-2090
Attn: HCPB Contract Coordinator

Amount: U.S. \$**[dollar number]** **[(dollar amount)]**

Expiry: **[Date]** at our counters

Dear Sirs:

1. At the request and on the instruction of our customer, **[name of applicant]** ("Applicant"), we, **[name of financial institution]** ("Issuer"), hereby establish in favor of the beneficiary, the California Department of Fish and Wildlife ("CDFW"), this irrevocable standby letter of credit ("Credit") in the principal sum of U.S. \$**[dollar number]** **[(dollar amount)]** ("Principal Sum").
2. We are informed this Credit is and has been established for the benefit of CDFW pursuant to the terms of the incidental take permit for the **[name of project]** issued by CDFW to the Applicant on **[date]** (No. **[number]**) ("Permit").
3. We are further informed that pursuant to the Permit, the Applicant has agreed to complete certain mitigation requirements in the Permit ("Mitigation Requirements").
4. We are finally informed that this Credit is intended by CDFW and the Applicant to serve as a security device for the performance by the Applicant of the Mitigation Requirements.
5. CDFW shall be entitled to draw upon this Credit only by presentation of a duly executed Certificate for Drawing ("Certificate") in the same form as Attachment A,

which is attached hereto, at our office located at [***name and address of financial institution***].

6. The Certificate shall be completed and signed by an Authorized Representative of CDFW as defined in paragraph 12 below. Presentation by CDFW of a completed Certificate may be made in person or by registered mail, return receipt requested, or by overnight courier.
7. Upon presentation of a duly executed Certificate as above provided, payment shall be made to CDFW, or to the account of CDFW, in immediately available funds, as CDFW shall specify.
8. If a demand for payment does not conform to the terms and conditions of this Credit, we shall give CDFW prompt notice that the demand for payment was not effected in accordance with the terms and conditions of this Credit, state the reasons therefore, and await further instruction.
9. Upon being notified that the demand for payment was not effected in conformity with the Credit, CDFW may correct any such non-conforming demand for payment under the terms and conditions stated herein.
10. All drawings under this Credit shall be paid with our funds. Each drawing honored by us hereunder shall reduce, *pro tanto*, the Principal Sum. By paying to CDFW an amount demanded in accordance herewith, we make no representations as to the correctness of the amount demanded.
11. This Credit will be cancelled upon receipt by us of Certificate of Cancellation, which: (i) shall be in the form of Attachment B, which is attached hereto, and (ii) shall be completed and signed by an Authorized Representative of CDFW, as defined in paragraph 12 below.
12. An Authorized Representative shall mean the Director of CDFW; the General Counsel of CDFW; a Regional Manager of CDFW; or the Branch Chief of CDFW's Habitat Conservation Planning Branch.
13. This Credit shall be automatically extended without amendment for additional periods of one year from the present or any future expiration date hereof, unless at least sixty (60) days prior to any such date, we notify CDFW in writing by registered mail, return receipt requested, or by overnight courier that we elect not to consider this Credit extended for any such period.
14. Communications with respect to this Credit shall be in writing and addressed to us at [***name and address of financial institution***], specifically referring upon such writing to this credit by number. The address for notices with respect to this Credit shall be: (i) for CDFW: Department of Fish and Wildlife, Habitat

Conservation Planning Branch, Post Office Box 944209, Sacramento, CA 94244-2090, Attn: HCPB Contract Coordinator; and (ii) for the Applicant: [***name and address of applicant***].

15. This Credit may not be transferred.
16. This Credit is subject to the International Standby Practices 1998 ("ISP 98"). As to matters not covered by the ISP 98 and to the extent not inconsistent with the ISP 98, this credit shall be governed by and construed in accordance with the Uniform Commercial Code, Article 5 of the State of California.
17. This Credit shall, if not canceled, expire on [***expiration date***], or any extended expiration date.
18. We hereby agree with CDFW that documents presented in compliance with the terms of this Credit will be duly honored upon presentation, as specified herein.
19. This Credit sets forth in full the terms of our undertaking. Such undertaking shall not in any way be modified, amended or amplified by reference to any document or instrument referred to herein or in which this Credit is referred to or to which this Credit relates and any such reference shall not be deemed to incorporate herein by reference any document or instrument.

[Name of financial institution]

By: _____
Name: _____
Title: _____
Telephone: _____

ATTACHMENT A

CERTIFICATE FOR DRAWING

[*CDFW Letterhead*]

[*Date*]

[*Name and address of financial institution*]

Re: Irrevocable Standby Letter of Credit No. [*number issued by financial institution*]

The undersigned, a duly Authorized Representative of the California Department of Fish and Wildlife (“CDFW”), as defined in paragraph 12 in the above-referenced standby letter of credit (“Credit”), hereby certifies to the Issuer that:

1. [*Insert one of the following statements:* “In the opinion of CDFW, the Applicant has failed to complete the Mitigation Requirements referenced in paragraph 3 of the Credit.” **or** “As set forth in paragraph 13, the Issuer has informed CDFW that the Credit will not be extended and the Applicant has not provided CDFW with an equivalent security approved by CDFW to replace the Credit.”]
2. The undersigned is authorized under the terms of the Credit to present this Certificate as the sole means of demanding payment on the Credit.
3. CDFW is therefore making a drawing under the Credit in amount of U.S. \$_____.
4. The amount demanded does not exceed the Principal Sum of the Credit.

Therefore, CDFW has executed and delivered this Certificate as of this ____day of [*month*], [*year*].

CALIFORNIA DEPARTMENT OF FISH AND WILDLIFE

[*Insert one of the following:* “Director” **or** “General Counsel” **or** “Regional Manager, [*Name of Regional Office*]” **or** “Chief, Habitat Conservation Planning Branch”]

ATTACHMENT B

CERTIFICATE FOR CANCELLATION

[CDFW Letterhead]

[Date]

[Name and address of financial institution]

Re: Irrevocable Standby Letter of Credit No. [**number issued by financial institution**]

The undersigned, a duly Authorized Representative of the California Department of Fish and Wildlife ("CDFW"), as defined in the paragraph 12 in the above-referenced Irrevocable Standby Letter of Credit ("Credit"), hereby certifies to the Issuer that:

1. [**Insert one of the following statements:** "The Applicant has presented documentary evidence of full compliance with the Mitigation Requirements referenced in paragraph 3 of the Credit." **or** "The Applicant has provided CDFW with an equivalent security approved by CDFW to replace the Credit."]
2. CDFW therefore requests the cancellation of the Credit.

Therefore, CDFW has executed and delivered this Certificate for Cancellation as of this ____ day of [**month**], [**year**].

CALIFORNIA DEPARTMENT OF FISH AND WILDLIFE

[Insert one of the following: "Director" **or** "General Counsel" **or** "Regional Manager, [**Name of Regional Office**]" **or** "Chief, Habitat Conservation Planning Branch"]

State of California - Department of Fish and Wildlife
MITIGATION PAYMENT TRANSMITTAL FORM
 DFW 1057 (REV.05/18/21)

Project Applicant Instructions: Please fill out and attach this form to payment. For conservation banks, also attach the Bill(s) of Sale for credits sold. One form may be used for multiple transactions, **BUT YOU MUST USE A SEPARATE FORM FOR EACH CHECK YOU TRANSMIT.** Make sure to include Project Name, Project Tracking Number, and ASB Mitigation Tracking Number (if available) on the attached payment type.

<p>1. DATE: _____</p> <p>TO: _____ Regional Manager</p> <p>_____</p> <p>Region Office Address</p>	<p>2. FROM: _____ Name</p> <p>_____</p> <p>Mailing Address</p> <p>_____</p> <p>City, State, Zip</p> <p>_____</p> <p>Telephone Number/FAX Number</p>
<p>3. RE: _____ Project Name as appears on permit/agreement</p>	

4. AGREEMENT/ACCOUNT INFORMATION: (check the applicable type)

2081 Permit
 Conservation Bank
 2835 NCCP
 1802 Agreement
 1600 Agreement
 Other _____

Project Tracking Number

5. PAYMENT TYPE (One check per form only): The following funds are being remitted in connection with the above referenced project:

Check information:

Total \$ _____ Check No. _____

Account No. _____ Bank Routing No. _____

- a. Endowment: for Long-Term Management Subtotal \$ _____
- b. Habitat Enhancement Subtotal \$ _____
- c. Security:
 - 1. Cash Refundable Security Deposit Subtotal \$ _____
 - 2. Letter of Credit Subtotal \$ _____
 - 1. Financial Institution: _____
 - 2. Letter of Credit Number: _____
 - 3. Date of Expiration: _____

ACCOUNTING OFFICE USE ONLY	
Description	FI\$Cal Coding
Speedchart (Project, Program, Reference, Fund)	
Reporting Structure	
Category	
Date Established: _____ By: _____	

Please send this form to asbmitigation@wildlife.ca.gov

Attachment 8

Minor Amendment No. 1 with Track Changes
For Amended Incidental Take Permit No. 2081-2020-037-06
Baldy Mesa Solar Project

1. The Authority Section has been amended as follows:

* * *

Permittee: Baldy Mesa Solar, LLC

Principal Officer: ~~Dallas Pugh~~ Theresa Carroll

Contact Person: ~~Dallas Pugh~~ Carisa Endrizzi-Davis (714) 785-7843

Mailing Address: 2180 S. 1300 E #~~600500~~
Salt Lake City, UT 84106
~~562-348-1119~~
~~aescepermittingteam~~
aescepermitting@aes.com

2. The Amended ITP Background section has been inserted preceding the Effective Date and Expiration section and describes Amendment No. 1 as follows:

* * *

On July 29, 2020, Baldy Mesa Solar, LLC submitted a CESA ITP application to CDFW pursuant to Fish and Game Code section 2081, subdivisions (b) and (c), and California Code of Regulations Title 14, section 783.0 et. seq. Baldy Mesa Solar, LLC sought take coverage authorization for CESA listed species associated with Project-related impacts from the Baldy Mesa Solar Project (Project) in San Bernardino County.

On March 17, 2022, CDFW issued ITP No. 2081-2020-037-06 to Baldy Mesa Solar, LLC (Permittee), authorizing take of Agassiz's desert tortoise (*Gopherus agassizii*), Mohave ground squirrel (*Xerospermophilus mohavensis*), and western Joshua tree (*Yucca brevifolia*) (collectively, the Covered Species) associated with and incidental to the Baldy Mesa Solar Project in San Bernardino County, California (Project). The Project as described in the ITP as originally issued by CDFW includes the construction of a ground-mounted, utility-scale solar energy and energy storage facility, with a generating capacity of up to 200 Megawatts (MW) located on approximately 1,197 acres. In issuing the ITP, CDFW found, among other things, that the Permittee's compliance with the Conditions of Approval of the ITP would fully mitigate Project impacts of the taking on the Covered Species and that issuance of the ITP would not jeopardize the continued existence of the Covered Species.

ITP Condition of Approval 8 requires the permanent protection and perpetual management of compensatory habitat to mitigate for impacts to Covered Species, and that the mitigation must be

complete within 18 months of the effective date of the ITP if Security is provided. The Permittee provided Security in the form of a letter of credit issued June 10, 2022. They have since been working to secure the required HM lands and have provided CDFW the preliminary information on proposed properties to fulfill the requirements.

In an application submitted September 7, 2023, the Permittee requested an additional 12 months to complete the mitigation. The extension is needed due to initial difficulty and delays in securing biologically suitable mitigation lands for the Covered Species, as well as necessary CDFW reviews and approvals. The Permittee will continue the letter of credit that was issued as security until the land is secured and approved.

CDFW finds that this Amendment is a Minor Amendment, as defined in California Code of Regulations, title 14, section 783.6, subdivision (c)(4).

Issuance of this Amendment will not increase the amount of take of the Covered Species compared to the Project as originally approved, nor will this Amendment increase other Project impacts on the Covered Species (i.e., “impacts of taking” as used in Fish and Game Code Section 2081, subd. (b)(2)).

Issuance of this Amendment does not affect CDFW’s previous determination that issuance of the ITP meets and is otherwise consistent with the permitting criteria set forth in Fish and Game Code section 2081, subdivisions (b) and (c).

CDFW now reissues this ITP including the revised provisions in this Minor Amendment (Collectively, the Amended ITP). The Amended ITP includes all of the operative provisions as of the effective date of this Amended ITP. Attachment 8 to this Amended ITP shows the specific red-line changes made to the ITP as a result of this Minor Amendment

3. The Effective Date and Expiration Date of this ITP section has been amended as follows:

~~This ITP~~The original ITP was executed in duplicate original form and became effective when a duplicate original was acknowledged by signature of the Permittee on the last page of the original ITP and returned to CDFW’s Habitat Conservation Planning Branch at the address listed in the Notices section of this ITP. The original ITP’s effective date was March 17, 2022. This remains the effective date for the original take authorization. The Amended ITP shall be executed in the same manner and shall become effective when signed by all parties and received by CDFW as described in the Notices section of this Amended ITP. Unless renewed by CDFW, this ITP and its authorization to take the Covered Species shall expire on **March 1, 2052.**

* * *

4. Condition of Approval 6. Monitoring, Notification and Reporting Provisions has been amended as follows:

* * *

6.5 Notifying Procedures. The Permittee or the Designated Representative shall provide all required notifications in this ITP by sending an email to the CDFW Regional Representative ~~Magdalena Rodriguez (Magdalena.Rodriguez~~[Rose Banks \(Rose.Banks@wildlife.ca.gov\)](mailto:Rose.Banks@wildlife.ca.gov) and as described in the Notices section of this ITP. All notifications shall be submitted via email to the Regional Representative and shall include the following information: ITP Number, the ITP Condition number that the notification is addressing, any necessary photos or attachments, and the name and phone numbers of the Biological Monitor(s) and/or Authorized Biologist(s) (if applicable).

* * *

6.7 Quarterly Compliance Report. The Designated Representative, Biological Monitor(s), and/or Authorized Biologist(s) shall compile the observation and inspection records identified in Condition of Approval 6.6 into a Quarterly Compliance Report and submit it to CDFW along with a copy of the MMRP table with notes showing the current implementation status of each mitigation measure. Quarterly Compliance Reports shall be submitted to the CDFW offices listed in the Notices section of this ITP and via e-mail to CDFW’s Regional Representative and Headquarters CESA Program. At the time of this ITP’s approval, the CDFW Regional Representative is ~~Magdalena Rodriguez~~[Rose Banks \(Magdalena.rodriguezRose.Banks@wildlife.ca.gov\)](mailto:Rose.Banks@wildlife.ca.gov) and Headquarters CESA Program email is CESA@wildlife.ca.gov. CDFW may at any time increase the timing and number of compliance inspections and reports required under this provision depending upon the results of previous compliance inspections. If CDFW determines the reporting schedule must be changed, CDFW will notify Permittee in writing of the new reporting schedule.

* * *

5. Condition of Approval 8. Habitat Management Land Acquisition has been amended as follows:

CDFW has determined that permanent protection and perpetual management of compensatory habitat is necessary and required pursuant to CESA to fully mitigate Project-related impacts of the taking on the Covered Species that will result from implementation of the Covered Activities. This determination is based on factors including an assessment of the importance of the habitat in the Project Area, the extent to which the Covered Activities will impact the habitat, and CDFW’s estimate of the protected acreage required to provide for adequate compensation.

To meet this requirement, the Permittee shall either purchase **612 acres** of Covered Species Mojave Ground Squirrel credits, **612 acres** of Covered Species Desert Tortoise credits, and **1,038 acres** of Covered Species Western Joshua Tree credits from a CDFW-approved mitigation or conservation bank pursuant to Condition of Approval 9.2 below OR shall provide for both the permanent protection and management of 612 acres of Covered Species Mojave Ground Squirrel, 612 acres of Covered Species Desert Tortoise, and 1,038 acres of Covered Species Western Joshua Tree Habitat Management (HM) lands pursuant to Condition of Approval 8.3 below and the

calculation and deposit of the management funds pursuant to Condition of Approval 9.4 below. Purchase of Covered Species credits OR permanent protection and funding for perpetual management of HM lands must be complete before starting Covered Activities, or within **1830 months** of the effective date of this ITP if Security is provided pursuant to Condition of Approval 9 below for all uncompleted obligations.

* * *

8.2 Covered Species Credits. If the Permittee elects to purchase Covered Species credits to complete compensatory mitigation obligations, then Permittee shall purchase 612 acres of Covered Species Mojave Ground Squirrel credits, 612 acres of Covered Species Desert Tortoise credits, and 1,038 acres of Covered Species Western Joshua Tree credits from a CDFW-approved mitigation or conservation bank prior to initiating Covered Activities, or no later than **1830 months** from the issuance of this ITP if Security is provided pursuant to Condition of Approval 9 below. Prior to purchase of Covered Species credits, Permittee shall obtain CDFW approval to ensure the mitigation or conservation bank is appropriate to compensate for the impacts of the Project. Permittee shall submit to CDFW a copy of the Bill of Sale(s) and Payment Receipt prior to initiating Covered Activities or within **1830 months** from issuance of this ITP if Security is provided.

* * *

6. Condition of Approval 9. Security has been amended as follows:

* * *

Even if Security is provided, the Permittee must complete the required acquisition, protection and transfer of all HM lands and record any required conservation easements no later than **1830 months** from the effective date of this ITP. CDFW may require the Permittee to provide additional HM lands and/or additional funding to ensure the impacts of the taking are minimized and fully mitigated, as required by law, if the Permittee does not complete these requirements within the specified timeframe.

7. The Notices section has been amended as follows:

* * *

Unless Permittee is notified otherwise, CDFW's Regional Representative for purposes of addressing issues that arise during implementation of this ITP is:

Magdalena Rodriguez

Rose Banks

3602 Inland Empire Boulevard, Suite C-220
Ontario, CA 91764

Telephone (~~909~~ 844-2520760) 218-0022
~~Magdalena.rodriguez~~Rose.Banks@wildlife.ca.gov

8. The Compliance with the California Environmental Quality Act section has been amended as follows:

* * *

None of the factors that would trigger the need for subsequent or supplemental environmental analysis of the Project under Public Resources Code section 21166 or California Code of Regulations, Title 14, section 15162 and 15163, exist as a result of this Amendment.

9. The Attachments section has been amended as follows:

FIGURE 1	Map of Project
ATTACHMENT 1	Mitigation Monitoring and Reporting Program
ATTACHMENT 2	Desert Tortoise Biologist Form
ATTACHMENT 3	GIS Data Collection Requirements
ATTACHMENT 4	Exclusion Fence
ATTACHMENT 5	Raven Management Renewable Deposit Document
ATTACHMENT 6	Irrevocable Letter of Credit
ATTACHMENT 7	Mitigation Payment Transmittal Form

ATTACHMENT 8 Minor Amendment No. 1 with Track Changes

Attachment 9

Minor Amendment No. 2 with Track Changes
for
Amended Incidental Take Permit No. 2081-2020-037-06-A2
Baldy Mesa Solar Project

1. The Authority Section has been amended as follows:

* * *

Permittee: Baldy Mesa Solar, LLC

Principal Officer: Theresa Carroll

Contact Person: ~~Carisa Endrizzi Davis (714) 785-7843~~ Ariel Szymanski, (916) 580-9632

Mailing Address: 2180 S. 1300 E #500
Salt Lake City, UT 84106
aescepermitting@aes.com

2. The Amended ITP Background section describes Amendment 2 as follows:

* * *

Amendment No. 1

In an application submitted September 7, 2023, the Permittee requested an additional 12 months to complete the mitigation. The extension was needed due to initial difficulty and delays in securing biologically suitable mitigation lands for the Covered Species, as well as necessary CDFW reviews and approvals. The Permittee will continue the letter of credit that was issued as security until the land is secured and approved. On December 7, 2023, Minor Amendment 1 was executed to allow the Permittee a total of 30 months from the effective date of the original ITP to complete the mitigation.

Amendment No. 2

On January 25, 2023, the Permittee submitted a package of proposed lands to meet the mitigation requirement for desert tortoise and Mohave ground squirrel, which CDFW deemed biologically suitable in a letter dated July 14, 2023. On June 10, 2024, the Permittee submitted additional proposed lands to meet the requirement for western Joshua tree, which CDFW deemed biologically suitable in a letter dated July 26, 2024. On September 5, 2024, the Permittee submitted all of the additional required documentation for CDFW to review for property acceptance.

Due to the size of the mitigation package and time required for CDFW staff to complete final review and approval, CDFW has determined that an additional six months is warranted for the Permittee to complete their mitigation and remain in compliance with ITP Condition of Approval 8.

CDFW finds that this Amendment is a Minor Amendment, as defined in California Code of Regulations, title 14, section 783.6, subdivision (c)(4).

Issuance of this Amendment will not increase the amount of take of the Covered Species compared to the Project as originally approved, nor will this Amendment increase other Project impacts on the Covered Species (i.e., “impacts of taking” as used in Fish and Game Code Section 2081, subd. (b)(2)).

Issuance of this Amendment does not affect CDFW’s previous determination that issuance of the ITP meets and is otherwise consistent with the permitting criteria set forth in Fish and Game Code section 2081, subdivisions (b) and (c).

CDFW now reissues this ITP including the revised provisions in this Minor Amendment (Collectively, the Amended ITP). The Amended ITP includes all of the operative provisions as of the effective date of this Amended ITP. Attachment **89** to this Amended ITP shows the specific red-line changes made to the ITP as a result of this Minor Amendment.

3. Condition of Approval 8. Habitat Management Land Acquisition has been amended as follows:

To meet this requirement, the Permittee shall either purchase **612 acres** of Covered Species Mojave Ground Squirrel credits, **612 acres** of Covered Species Desert Tortoise credits, and **1,038 acres** of Covered Species Western Joshua Tree credits from a CDFW-approved mitigation or conservation bank pursuant to Condition of Approval 9.2 below OR shall provide for both the permanent protection and management of 612 acres of Covered Species Mojave Ground Squirrel, 612 acres of Covered Species Desert Tortoise, and 1,038 acres of Covered Species Western Joshua Tree Habitat Management (HM) lands pursuant to Condition of Approval 8.3 below and the calculation and deposit of the management funds pursuant to Condition of Approval 9.4 below. Purchase of Covered Species credits OR permanent protection and funding for perpetual management of HM lands must be complete before starting Covered Activities, or within **3036 months** of the effective date of this ITP if Security is provided pursuant to Condition of Approval 9 below for all uncompleted obligations.

* * *

8.2 Covered Species Credits. If the Permittee elects to purchase Covered Species credits to complete compensatory mitigation obligations, then Permittee shall purchase 612 acres of Covered Species Mojave Ground Squirrel credits, 612 acres of Covered Species Desert Tortoise credits, and 1,038 acres of Covered Species Western Joshua Tree credits from a CDFW-approved mitigation or conservation bank prior to initiating Covered Activities, or no later than **3036** months from the issuance of this ITP if Security is provided pursuant to Condition of Approval 9 below. Prior to purchase of Covered Species credits, Permittee shall obtain CDFW approval to ensure the mitigation or conservation bank is appropriate to compensate for the impacts of the Project. Permittee shall submit to CDFW a copy of the Bill of Sale(s) and Payment Receipt prior to initiating Covered Activities or within **3036** months from issuance of this ITP if Security is provided.

4. Condition of Approval 9. Security has been amended as follows:

* * *

Even if Security is provided, the Permittee must complete the required acquisition, protection and transfer of all HM lands and record any required conservation easements no later than **3036 months** from the effective date of this ITP. CDFW may require the Permittee to provide additional HM lands and/or additional funding to ensure the impacts of the taking are minimized and fully mitigated, as required by law, if the Permittee does not complete these requirements within the specified timeframe.

5. The Attachments section has been amended as follows:

- | | |
|---------------------|---|
| FIGURE 1 | Map of Project |
| ATTACHMENT 1 | Mitigation Monitoring and Reporting Program |
| ATTACHMENT 2 | Desert Tortoise Biologist Form |
| ATTACHMENT 3 | GIS Data Collection Requirements |
| ATTACHMENT 4 | Exclusion Fence |
| ATTACHMENT 5 | Raven Management Renewable Deposit Document |
| ATTACHMENT 6 | Irrevocable Letter of Credit |
| ATTACHMENT 7 | Mitigation Payment Transmittal Form |
| ATTACHMENT 8 | Minor Amendment No. 1 with Track Changes |
| <u>ATTACHMENT 9</u> | <u>Minor Amendment No. 2 with Track Changes</u> |

ISSUED BY THE CALIFORNIA DEPARTMENT OF FISH AND WILDLIFE ON

Heidi Calvert, Regional Manager
Inland Deserts Region

ACKNOWLEDGMENT

~~The undersigned: (1) warrants that he or she is acting as a duly authorized representative of the Permittee, (2) acknowledges receipt of this ITP, and (3) agrees on behalf of the Permittee to comply with all terms and conditions.~~

By: _____ Date: _____

Printed Name: Theresa Carroll Title: _____