



California Department of Fish and Wildlife
Inland Deserts Region
3602 INLAND EMPIRE BLVD., C-220
ONTARIO, CA 91764

California Endangered Species Act
Incidental Take Permit No. 2081-2025-037-06

CEMEX PROJECT PHASE 1

I. Authority:

This California Endangered Species Act (CESA) incidental take permit (ITP) is issued by the California Department of Fish and Wildlife (CDFW) pursuant to Fish and Game Code section 2081, subdivisions (b) and (c), and California Code of Regulations, Title 14, section 783.0 et seq. CESA prohibits the take¹ of any species of wildlife designated by the California Fish and Game Commission as an endangered, threatened, or candidate species.² However, CDFW may authorize the take of any such species by permit pursuant to the conditions set forth in Fish and Game Code section 2081, subdivisions (b) and (c). (See Cal. Code Regs., tit. 14, § 783.4.)

Permittee:	Cemex Construction Materials Pacific, LLC
Principal Officer:	David Beck, Vice President
Contact Person:	Christine Jones
Mailing Address:	4120 E. Jurupa Street, Suite 202 Ontario, CA 91761

II. Effective Date and Expiration Date of this ITP:

This ITP is effective as of the date signed by CDFW below. Unless renewed by CDFW, this ITP and its authorization to take the Covered Species shall expire on **January 1, 2035**.

Notwithstanding the expiration date on the take authorization provided by this ITP, Permittee's obligations pursuant to this ITP do not end until CDFW accepts as complete the Permittee's Final Mitigation Report required by Condition of Approval 7.6 of this ITP.

¹Pursuant to Fish and Game Code section 86, "'take' means hunt, pursue, catch, capture, or kill, or attempt to hunt, pursue, catch, capture, or kill." (See also *Environmental Protection Information Center v. California Department of Forestry and Fire Protection* (2008) 44 Cal.4th 459, 507 [for purposes of incidental take permitting under Fish and Game Code section 2081, subdivision (b), "'take' ... means to catch, capture or kill".])

²The definition of an endangered, threatened, and candidate species for purposes of CESA are found in Fish and Game Code sections 2062, 2067, and 2068, respectively.

III. Project Location:

The Cemex Phase 1 Project (Project) is located within the City of Redlands, San Bernardino County (See Figure 1). The center of the Project is located at approximately (34.097423, -117.166391). The Project site is bounded by Plunge Creek and Santa Ana River to the north and south, respectively, as well as existing mining areas to the north and south.

IV. Project Description:

Project includes extraction, processing, separation, stockpiling and selling of sand, gravel, rocks and other construction aggregate materials. New extraction will occur within the 51.8-acre footprint. (Fig 1) Take authorization will also be extended to the surrounding, previously mined, 121-acre area.

New material will be excavated from the phase 1 mining area using standard open pit mining techniques of pushing material with a dozer to a working level, removing and loading material with a loader to off-road haul trucks and/or directly onto processing plant feed conveyor belts where the material will be crushed and screened. The extraction area elevation will be lowered until the excavated footprint reaches a depth of approximately 120 feet below original grade.

Removed raw aggregate material will be loaded into haul trucks and transported within previously mined or disturbed areas to the existing processing plant for processing. No new structures or equipment are proposed as part of this project.

Mining activities in the Phase 1 area (51.8 acres) will be conducted in two subphases:

- Area 1 “Phase 1” (21.8 acres) approximately 4 years,
- Area 2 “Phase 2” (30 acres) approximately 4.4 years.

Reclamation of finished slopes (2:1 slope) will begin as the mining phases are completed. Reclamation will consist of ripping compacted mining pit floors and slopes, slope contouring, and revegetation of the upper slopes with species native to the Upper Santa Ana River Wash.

Equipment used will include dozers, loaders, excavators, backhoes, bobcats, and off-road haul trucks. The project site will be accessed through Orange Street, and all internal traffic will occur in previously disturbed mine areas. During initial ground clearance, Cemex will use existing access road which extends from the Cemex plant and quarry west of the Phase 1 project area. (Fig 1)

V. Covered Species Subject to Take Authorization Provided by this ITP:

This ITP covers the following species:

<u>Name</u>	<u>CESA Status</u> ³
1. San Bernardino kangaroo rat (<i>Dipodomys merriami parvus</i>)	Endangered ⁴

³ Under CESA, a species may be on the list of endangered species, the list of threatened species, or the list of candidate species.

⁴See Cal. Code Regs. tit. 14 § 670.5, subd. (a)(6)(K).

limitations described in this section and the Conditions of Approval identified below. This ITP does not authorize take of Covered Species from activities outside the scope of the Covered Activities, take of Covered Species outside of the Project Area, take of Covered Species resulting from violation of this ITP, or intentional take of Covered Species except for capture and relocation of Covered Species as authorized by this ITP.

VIII. Conditions of Approval:

Unless specified otherwise, the following measures apply to all Covered Activities within the Project Area, including areas used for vehicular ingress and egress, staging and parking, and noise and vibration generating activities that may/will cause take. CDFW's issuance of this ITP and Permittee's authorization to take the Covered Species are subject to Permittee's compliance with and implementation of the following Conditions of Approval:

- 1. Legal Compliance:** Permittee shall comply with all applicable federal, state, and local laws in existence on the effective date of this ITP or adopted thereafter.
- 2. CEQA Compliance:** Permittee shall implement and adhere to the mitigation measures related to the Covered Species in the Biological Resources section of Environmental Impact Report (SCH No.: 2004051023) certified by the San Bernardino Valley Water Conservation District on March 24, 2008 as lead agency for the Project pursuant to the California Environmental Quality Act (CEQA) (Pub. Resources Code, § 21000 et seq.).
- 3. ESA Compliance:** Permittee, as a Participating Entity under the Upper Santa Ana Wash Habitat Conservation Plan, San Bernardino County, California (FWS-SB-08B0318-20F1299) (HCP), shall implement and adhere to the terms and conditions related to the Covered Species in the HCP and the Intra-Service Biological and Conference Opinion on the Issuance of an Endangered Species Act Section 10(a)(1)(B) Permit (TE 78703D and TE 78704D) if Permittee receives a Certificate of Inclusion under the processes specified in the HCP. For purposes of this ITP, where the terms and conditions for the Covered Species in the federal authorization are less protective of the Covered Species or otherwise conflict with this ITP, the conditions of approval set forth in this ITP shall control.
- 4. ITP Time Frame Compliance:** Permittee shall fully implement and adhere to the conditions of this ITP within the time frames set forth below and as set forth in the Mitigation Monitoring and Reporting Program (MMRP), which is included as Attachment 1 to this ITP.
- 5. General Provisions:**
 - 5.1. Designated Representative.** Before starting Covered Activities, Permittee shall designate a representative (Designated Representative) responsible for communications with CDFW and overseeing compliance with this ITP. Permittee shall notify CDFW in writing before starting Covered Activities of the Designated Representative's name, business address, and

contact information, and shall notify CDFW in writing if a substitute Designated Representative is selected or identified at any time during the term of this ITP.

- 5.2. Designated Biologist(s) and Biological Monitor(s).** Permittee shall submit to CDFW in writing the name, qualifications, business address, and contact information of the Designated Biologist(s) and Biological Monitor(s) using the Biologist Resume Form (ATTACHMENT 2) or another format containing the same information at least 30 days before starting Covered Activities. Permittee shall ensure that the Designated Biologist(s) and Biological Monitor(s) are knowledgeable and experienced in the biology, natural history, collecting and handling of the Covered Species. The Designated Biologist(s) and Biological Monitor(s) shall be responsible for monitoring Covered Activities to help minimize and fully mitigate or avoid the incidental take of individual Covered Species and to minimize disturbance of Covered Species' habitat. Permittee shall obtain CDFW approval of the Designated Biologist(s) and Biological Monitor(s) in writing before starting Covered Activities and shall also obtain approval in advance, in writing, if the Designated Biologist(s) or Biological Monitor(s) must be changed.
- 5.3. Designated Biologist Authority.** To ensure compliance with the Conditions of Approval of this ITP, the Designated Biologist shall immediately stop any activity that does not comply with this ITP and/or order any reasonable measure to avoid the unauthorized take of an individual of the Covered Species. Permittee shall provide unfettered access to the Project Site and otherwise facilitate the Designated Biologist in the performance of his/her duties. If the Designated Biologist is unable to comply with the ITP, then the Designated Biologist shall notify the CDFW Representative immediately. Permittee shall not enter into any agreement or contract of any kind, including but not limited to non-disclosure agreements and confidentiality agreements, with its contractors and/or the Designated Biologist that prohibit or impede open communication with CDFW, including but not limited to providing CDFW staff with the results of any surveys, reports, or studies or notifying CDFW of any non-compliance or take. Failure to notify CDFW of any non-compliance or take or injury of a Covered Species as a result of such agreement or contract may result in CDFW taking actions to prevent or remedy a violation of this ITP.
- 5.4. Education Program.** Permittee shall conduct an education program for all persons employed or otherwise working in the Project Area before performing any work. The program shall consist of a presentation from the Designated Biologist that includes a discussion of the biology and general behavior of the Covered Species, information about the distribution and habitat needs of the Covered Species, sensitivity of the Covered Species to human activities, its status pursuant to CESA including legal protection, recovery efforts, penalties for violations and Project-specific protective measures described in this ITP. Permittee shall prepare and distribute wallet-sized cards or a fact sheet handout containing this information for workers to carry in the Project Area. Permittee shall provide interpretation for non-English speaking workers, and the same instruction shall be provided

to any new workers before they are authorized to perform work in the Project Area. Upon completion of the program, employees shall sign a form stating they attended the program and understand all protection measures. This training shall be repeated at least once annually for long-term and/or permanent employees that will be conducting work in the Project Area.

- 5.5. Construction Monitoring Documentation.** The Designated Biologist(s) and Biological Monitor(s) shall maintain construction-monitoring documentation on-site in either hard copy or digital format throughout the construction period, which shall include a copy of this ITP with attachments and a list of signatures of all personnel who have successfully completed the education program. Permittee shall ensure a copy of the construction-monitoring documentation is available for review at the Project site upon request by CDFW.
- 5.6. Trash Abatement.** Permittee shall initiate a trash abatement program before starting Covered Activities and shall continue the program for the duration of the Project. Permittee shall ensure that trash and food items are contained in animal-proof containers and removed, ideally at daily intervals but at least once a week, to avoid attracting opportunistic predators such as ravens, coyotes, and feral dogs.
- 5.7. Dust Control.** Permittee shall implement dust control measures during Covered Activities to facilitate visibility for monitoring of the Covered Species by the Designated Biologist. Permittee shall keep the amount of water used to the minimum amount needed and shall not allow water to form puddles.
- 5.8. Erosion Control Materials.** Permittee shall prohibit use of erosion control materials potentially harmful to Covered Species and other species, such as monofilament netting (erosion control matting) or similar material, in potential Covered Species' habitat.
- 5.9. Delineation of Property Boundaries.** Before starting Covered Activities along each part of the route in active construction, Permittee shall clearly delineate the boundaries of the Project Area with fencing, stakes, or flags. Permittee shall restrict all Covered Activities to within the fenced, staked, or flagged areas. Permittee shall maintain all fencing, stakes, and flags until the completion of Covered Activities in that area.
- 5.10. Delineation of Habitat.** Permittee shall clearly delineate habitat of the Covered Species within the Project Area with posted signs, posting stakes, flags, and/or rope or cord, and place fencing as necessary to minimize the disturbance of Covered Species' habitat.
- 5.11. Project Access.** Project-related personnel shall access the Project Area using existing routes, or routes identified in the Project Description and shall not cross Covered Species' habitat outside of or en route to the Project Area. Permittee shall restrict Project-related vehicle traffic to established roads, staging, and parking areas. Permittee shall ensure that vehicle

speeds do not exceed 20 miles per hour to avoid Covered Species on or traversing the roads. If Permittee determines construction of routes for travel are necessary outside of the Project Area, the Designated Representative shall contact CDFW for written approval before carrying out such an activity. CDFW may require an amendment to this ITP, among other reasons, if additional take of Covered Species will occur as a result of the Project modification.

- 5.12. Staging Areas.** Permittee shall confine all Project-related parking, storage areas, laydown sites, equipment storage, and any other surface-disturbing activities to the Project Area using, to the extent possible, previously disturbed areas. Additionally, Permittee shall not use or cross Covered Species' habitat outside of the marked Project Area unless provided for as described in Condition of Approval 5.11 of this ITP.
- 5.13. Hazardous Waste.** Permittee shall immediately stop and, pursuant to pertinent state and federal statutes and regulations, arrange for repair and clean up by qualified individuals of any fuel or hazardous waste leaks or spills at the time of occurrence, or as soon as it is safe to do so. Permittee shall exclude the storage and handling of hazardous materials from the Project Area and shall properly contain and dispose of any unused or leftover hazardous products off-site.
- 5.14. CDFW Access.** Permittee shall provide CDFW staff with reasonable access to the Project and mitigation lands under Permittee control and shall otherwise fully cooperate with CDFW efforts to verify compliance with or effectiveness of mitigation measures set forth in this ITP.
- 5.15. Refuse Removal.** Upon completion of Covered Activities, Permittee shall remove from the Project Area and properly dispose of all temporary fill and construction refuse, including, but not limited to, broken equipment parts, wrapping material, cords, cables, wire, rope, strapping, twine, buckets, metal or plastic containers, and boxes.

6. Monitoring, Notification and Reporting Provisions:

- 6.1. Notification Before Commencement.** The Designated Representative shall notify CDFW 14 calendar days before starting Covered Activities and shall document compliance with all pre-Project Conditions of Approval before starting Covered Activities.
- 6.2. Notification of Non-compliance.** The Designated Representative shall immediately notify CDFW if the Permittee is not in compliance with any Condition of Approval of this ITP, including but not limited to any actual or anticipated failure to implement measures within the time periods indicated in this ITP and/or the MMRP. The Designated Representative shall follow up within 24 hours with a written report to CDFW describing, in detail, any non-compliance with this ITP and suggested measures to remedy the situation.

6.3. Compliance Monitoring. The Designated Biologist shall be on-site daily when Covered Activities, such as habitat clearings, fence installations, and new disturbances occur. CDFW discussion and approval is required if either a Designated Biologist is no longer needed or if a reduction in frequency is needed. The Designated Biologist shall conduct compliance inspections to:

- (1) minimize incidental take of the Covered Species;
- (2) prevent unlawful take of species;
- (3) check for compliance with all measures of this ITP;
- (4) check all exclusion zones; and
- (5) ensure that signs, stakes, and fencing are intact, and that Covered Activities are only occurring in the Project Area.

The Designated Representative or Designated Biologist shall prepare daily written observation and inspection records summarizing oversight activities and compliance inspections, observations of Covered Species and their sign, survey results, and monitoring activities required by this ITP.

6.4. Compliance Reports. The Designated Representative or Designated Biologist shall compile the observation and inspection records identified in Condition of Approval 6.3 into a Monthly Compliance Report while initial clearing, fencing, and trapping occurs for each sub-phase (1 and 2) of the project. Once excavation begins in each subphase, the project can submit a written request to CDFW to switch to quarterly compliance reports. These reports shall be submitted to CDFW along with a copy of the MMRP table with notes showing the current implementation status of each mitigation measure. Compliance Reports shall be submitted to the CDFW offices listed in the Notices section of this ITP and via e-mail to CDFW's Regional Representative and Headquarters CESA Program. At the time of this ITP's approval, the CDFW Regional Representative is Chelsea Price (chelsea.price@wildlife.ca.gov) and Headquarters CESA Program email is CESA@wildlife.ca.gov. CDFW may at any time increase the timing and number of compliance inspections and reports required under this provision depending upon the results of previous compliance inspections. If CDFW determines the reporting schedule must be changed, CDFW will notify Permittee in writing of the new reporting schedule.

6.5. Annual Status Report. Permittee shall provide CDFW with an Annual Status Report (ASR) no later than January 31 of every year beginning with issuance of this ITP and continuing until CDFW accepts the Final Mitigation Report identified below. Each ASR shall include, at a minimum: (1) a summary of all Compliance Reports for that year identified in Condition of Approval 6.4; (2) a general description of the status of the Project Area and Covered Activities, including actual or projected completion dates, if known; (3) a copy of the table

in the MMRP with notes showing the current implementation status of each mitigation measure; (4) an assessment of the effectiveness of each completed or partially completed mitigation measure in avoiding, minimizing and mitigating Project impacts; (5) all available information about Project-related incidental take of the Covered Species; (6) an accounting of the number of acres subject to both temporary and permanent disturbance, both for the prior calendar year, and a total since ITP issuance; and (7) information about other Project impacts on the Covered Species.

6.6. CNDDDB Observations. The Designated Biologist shall submit all observations of Covered Species to CDFW's California Natural Diversity Database (CNDDDB) within 60 calendar days of the observation, and the Designated Biologist shall include copies of the submitted forms with the next Compliance Report or ASR, whichever is submitted first relative to the observation.

6.7. Final Mitigation Report. No later than 45 days after completion of all mitigation measures, Permittee shall provide CDFW with a Final Mitigation Report. The Designated Biologist shall prepare the Final Mitigation Report which shall include, at a minimum: (1) a summary of all Compliance Reports and all ASRs; (2) a copy of the table in the MMRP with notes showing when each of the mitigation measures was implemented; (3) all available information about Project-related incidental take of the Covered Species; (4) information about other Project impacts on the Covered Species; (5) beginning and ending dates of Covered Activities; (6) an assessment of the effectiveness of this ITP's Conditions of Approval in minimizing and fully mitigating Project impacts of the taking on Covered Species; (7) recommendations on how mitigation measures might be changed to more effectively minimize take and mitigate the impacts of future projects on the Covered Species; and (8) any other pertinent information.

6.8. Notification of Take or Injury/Damage. Permittee shall immediately notify the Designated Biologist if a Covered Species is taken or injured/damaged by a Project-related activity, or if a Covered Species is otherwise found dead or injured/damaged within the vicinity of the Project. The Designated Biologist or Designated Representative shall provide initial notification to CDFW by calling the Regional Office at (909) 484-0167. The initial notification to CDFW shall include information regarding the location, species, and number of animals/plants taken or injured/damaged and the ITP Number. Following initial notification, Permittee shall send CDFW a written report within two calendar days. The report shall include the date and time of the finding or incident, location of the animal/plant or carcass, and if possible, provide a photograph, explanation as to cause of take or injury/damage, and any other pertinent information.

7. Take Minimization Measures: The following requirements are intended to ensure the minimization of incidental take of Covered Species in the Project Area during Covered Activities.

Permittee shall implement and adhere to the following conditions to minimize take of Covered Species:

Santa Ana River Woollystar and Slender-Horned Spineflower

- 7.1. Harvesting of Covered Species Seeds.** During the appropriate season before commencing project activities in each sub-phase (1 and 2), an entity holding an MOU for Covered Species shall conduct Covered Species surveys for the affected phase and shall commence seed harvesting from all Covered Species individual plants located within the Project Area that are anticipated to be incidentally taken as a result of Covered Activities. Permittee shall notify CDFW 14 days before surveys and collection are set to commence. The notification shall include a figure of the proposed survey transects and methods of seed collection and storage. Permittee shall store a portion of the seeds (quantity to be determined by the Designated Biologist and discussed with CDFW) for dispersal post-Project within appropriate restoration areas associated with the Project. Permittee shall donate the remainder of the harvested seeds to a local botanic garden or other entity holding appropriate permits for the species for future propagation and/or research purposes. Within 14 days of seed collection, Permittee shall submit results of the survey as KMZ locations and compiled in figure, as well as the amount of seed collected to CDFW.
- 7.2. Slender-Horned Spineflower Monitoring.** Permittee shall annually monitor Covered Species individuals/occurrences within a 300-ft buffer of the Project site. If a decline in individuals occurs (mortality or a significant reduction in annual recruitment), the Designated Biologist(s) shall notify CDFW and shall discuss a path forward (modification of permit terms, seed collection, soil harvesting, seed storage, etc.).

San Bernardino Kangaroo Rat

- 7.3. Season Restriction.** Permittee shall avoid initiating Covered and Relocation Activities within occupied habitat during peak breeding season (February 15 through September 15).
- 7.4. Burrow Mapping.** No less than 90 days prior to the initiation of Covered Activities at each subphase (including exclusionary fencing installation), unless otherwise approved by CDFW, the Designated Biologist(s) shall identify and map all potential kangaroo rat burrows within the Project Area subphase) and 500-foot buffer, unless otherwise approved by CDFW, surrounding the Project Area. KMZ locations of the kangaroo rat burrows and a compiled map shall be provided to CDFW within 2 weeks of completing the burrow mapping survey.
- 7.5. SBKR Trapping Plan.** No less than 90 days prior to the initiation of Covered Activities of each subphase (including exclusionary fencing installation), Designated Biologist(s) shall design small mammal trapping grids/transects for CDFW review and approval. Transects/grids shall be submitted in both pdf and KMZ formats. To achieve total coverage of Covered Species

suitable habitat, transects shall be used within narrow linear habitat and grids shall be used within larger areas of habitat. Transects and grids shall be established within the Project Area and 100-foot buffer surrounding the Project Area. Trap locations shall be geographically indexed with latitude/longitude coordinates along with the datum used (e.g., degrees/minutes/seconds, decimal degrees, etc.). The grids shall be distributed throughout the Project Area and 100-foot buffer. The trapping plan shall also include the potential for burrow casting of identified and confirmed Covered Species burrows. This casting shall be completed by a CDFW approved qualified entity.

- 7.6. Exclusionary Fencing Installation.** No less than 60 days prior to the initiation of Covered Activities of each subphase, or as otherwise approved by CDFW in writing, Permittee shall submit to CDFW for review and approval an Exclusionary Fencing Plan detailing the location(s), installation methodology, fencing design and material. No more than 10 days prior to the initiation of any Covered Activities, Permittee shall install fencing to exclude Covered Species from the Project Area and roads around the perimeter of construction zones to limit the potential for Covered Species to enter these zones. The Designated Biologist shall be present during the fence installation. Fencing will be maintained during the duration of Covered Activities of each subphase.
- 7.7. Covered Species Relocation Plan.** Prior to relocation, the Designated Biologist(s), in coordination with an entity experienced in conducting small mammal relocation research, shall submit to CDFW for review and approval a Relocation Plan no less than 90 days prior to beginning any Covered Activity (including exclusionary fence installation), or as otherwise approved by CDFW in writing. The relocation plan shall be amended 90 days prior to the start of Covered Activities of each subphase. The Relocation Plan shall include trapping methods, relocation methods, monitoring methods, data to be collected, potential success criteria, and adaptive management. Implementation of the plan shall be carried out by a CDFW approved Designated Biologist(s). The relocation area size is dependent on the anticipated number of animals in each subphase and shall be a minimum of 15 acres of high-quality Covered Species habitat. A portion of the relocation area, to be discussed with CDFW, shall be fenced to anchor the Covered Species to the site. If adequate vegetative barriers exist, fencing may not be required. The plan shall be developed based on Condition of Approvals 7.8, 7.9, 7.10, and 7.11 below and at a minimum include: spatial maps of kangaroo rat burrow mapping within the Project impact area and adjacent 500 foot buffer; map and habitat quality of proposed relocation area(s); small mammal trapping results within the proposed relocation area(s); any uplift and non-native management needed in the relocation area(s); locations in the relocation area(s) that have natural barriers or that can be fenced; method of post-relocation monitoring (i.e. surveys of passively marked animals, transmitters, PIT tags. Note: If PIT tags are used then locations of antenna arrays shall be provided. Application of transmitters or PIT tags must be completed by a qualified biologist holding appropriate permits for SBKR approved by CDFW (Condition of Approval

7.8.6). This qualified biologist shall also advise on the post-monitoring protocol; post relocation trapping sessions shall occur at months 1, 3, 6, 9, and yearly thereafter; success criteria and any other details related to relocation. Results of mapping, trapping and habitat quality shall be provided to CDFW in both KMZ and pdf format. Relocation Plan shall also include the location of the Covered Species holding facility, number and design of small mammal holders, feeding amount and schedule, and anticipated amount of time animals will be held.

7.8. Covered Species Trapping and Handling. Within 7 days following the installation of the exclusionary fence in each subphase, the Designated Biologist(s) shall perform the following:

7.8.1. The Designated Biologist(s) shall conduct small mammal trapping within the exclusionary fenced area and 100-foot buffer for each subphase of the project according to Condition of Approval 7.5 and informed by Condition of Approval 7.4. If the mining pit is inundated, the 100-ft buffer may be reduced with CDFW written approval. Small mammal trapping within the Project Area shall continue for a minimum of 5 consecutive nights with at least 3 consecutive nights of no Covered Species captures. The Designated Biologist(s) shall conduct trapping when the nightly low temperature is forecast to be 40 degrees Fahrenheit or above, and if no extended periods of wind, rain, fog, or other inclement weather will occur to make conditions unsuitable for trapping or will unduly imperil the lives of the animals. If temperature is forecast to drop below 40 degrees, at the discretion of the Designated Biologist, trapping will be postponed, or traps will be set, then checked and closed at midnight. To distinguish individuals, the Designated Biologist(s) shall be marked (e.g. permanent marker, dye, shaving, and passive integrated transponder (PIT) tags) utilizing a methodology approved in the Covered Species Trapping Plan (Condition of Approval 7.5). For individuals captured inside the exclusionary fence, the Designated Biologist(s) shall record captured kangaroo rats' approximate age, gender, mass, reproductive status, physical condition (pelage condition sign of ectoparasites), and trap location.

7.8.2. If a lactating female is captured within the exclusion fence, it shall be released and followed to determine where its burrow is located. If a lactating female is observed, the Designated Biologist shall leave the burrow undisturbed, establish a conservative buffer, and contact CDFW within 24 hours to coordinate on the most appropriate path forward. If a pregnant female is captured, the Designated Biologist shall relocate the female in accordance with Condition of Approval 7.7 and provide an enhanced diet (powdered milk, extra leafy greens, etc.) and feeding schedule. The female shall be soft released within 72 hours. The Designated Biologist shall establish a wildlife camera at the artificial burrow to monitor behavior.

- 7.8.3. If a juvenile, nonlactating female or male is captured, the individual(s) shall be “soft” released within 72 hours as specified in Condition of Approvals 7.7 & 7.9.
- 7.8.4. All individuals captured within the exclusion fence shall be evaluated as candidates to receive transmitters based on weight and reproductive status (see Condition of Approval 7.8.6). Animals captured within the exclusionary fence, of appropriate weight and reproductive status shall be held in individual cages in a temperature-controlled location where daylight is excluded until transmitters can be fitted or applied on the individuals by a Designated Biologist with experience fitting and assessing harness functionality or PIT tags and their impacts on the Covered Species. Individuals newly fitted with harnesses shall be held for 24 hours to observe the fit and function of the transmitter harness before being released. If an individual proves to be unfit or unable to wear a harness, the Designated Biologist shall remove the harness and transmitter before release.
- 7.8.5. If utilizing harness transmitters, the Designated Biologist(s) shall affix ear tags with a unique alphanumeric code to all kangaroo rats. The Designated Biologist(s) shall affix radio transmitters on SBKR Covered Species individuals as described in Conditions of Approval 7.8.6.
- 7.8.6. If utilizing harness transmitters, the Designated Biologist(s) with previous experience fitting and assessing harness functionality and impact (e.g., Dr. Shier or other similarly qualified, CDFW-approved person) shall place or oversee the placement of Very High Frequency (VHF) radio transmitters (e.g., Holohil Systems [model BD- 2C]) with a plastic-coated loop and crimp attachment system backpack harness, created from a modified figure 8 design used for small passerine birds (10-200 g) (Rappole & Tipton 1991) and Wildlife Materials International transmitters [SOM-2038 HWSC] with a cable tie attachment system) on males of the Covered Species so that movements and survival can be monitored after release by receiver or sensor. The loops of the figure 8 wrap around the animal’s front legs and the transmitter sits across the animals’ back (Shier and Swaisgood 2012). The transmitters shall generally be 5% of body mass or less.
- 7.8.7. The Designated Biologist(s) shall record captured kangaroo rats’ age, gender, reproductive status, mass, and trap location.
- 7.8.8. All small mammals shall be released in accordance with Condition of Approval 7.7, following the installation of tracking devices and recordation of data as described in Condition of Approval 7.8.7;
- 7.9. Soft Release Exclusion.** To limit dispersal and allow Covered Species to acclimate to relocation, the Designated Biologist(s) shall perform a “soft release” at a CDFW-approved location, as approved in the Covered Species Relocation Plan. The number and location of

“soft release” retention cages will be informed by the results of pre-exclusionary fence burrow mapping (Condition of Approval 7.3):

- 7.9.1. Construct above-ground wire mesh retention cage using 6.4 mm (1/4) in hardware cloth, each measuring about 90 x 60 cm (23.6 x 35.4 in) and closed on the top and open on the bottom (Refer to Figure 2);
- 7.9.2. Dig burrows into the ground using a soil auger that is approximately the same diameter as a Covered Species burrow (45 mm) at roughly a 30° angle to a length of 1 m (3.3 feet). To maintain the integrity of the created burrow, cardboard mailing tubes, or other structural material shall be placed in the burrow, as required. The burrows shall be established outside of the exclusionary fencing in the same approximate neighbor relationship as trapped, and as approved by CDFW. Holes should be close to natural size.
- 7.9.3. Place each retention cage over the burrow. The sides of the cage will be buried to an approximate depth of 20 cm (8 in) to discourage animals from digging out;
- 7.9.4. Place retention cages/burrows at least 10-15 m apart to avoid aggressive interactions when the retention cage is removed, unless trapping and burrow mapping suggests otherwise;
- 7.9.5. Move Covered Species individuals from the Project Area to the outside of the exclusionary fencing in the same approximate neighbor relationship as trapped and approved by CDFW;
- 7.9.6. Install remote infrared wildlife cameras as 10% of the enclosures, or 10 cameras, whichever is greater to video record activity during acclimation and for 30 days following removal of the cage. If, after placing one camera at each enclosure there are cameras remaining from the 10 total cameras, the additional cameras shall be placed along the exclusionary fence line closest to each relocation area;
- 7.9.7. Place each relocated Covered Species individual into its own retention cage for 7-10 days to allow acclimation to the release site and dampen dispersal. The burrow entrance shall be plugged during the day and unplugged each night to allow the individual to enter into the cage;
- 7.9.8. Feed Covered Species individuals a combination of romaine lettuce, inoculated finch seed mix, and plant seeds native to the release site daily while in the retention cage/burrow. Seed shall be microwaved for 1-3 minutes before broadcast at the release site to prevent seed germination and alteration of the native vegetation community;

- 7.9.9. After 7-10 days, remove the retention cages. Use any saved sand from the individual's holding cage or trapping site to sprinkle around the entrance of the artificial burrow;
- 7.9.10. Provide CDFW daily updates, or as otherwise approved by CDFW in writing, on the status of the Covered Species during, and 30 days following, the soft release, including any camera data information (activity period, behaviors, physical trauma, predation attempts), daily monitoring summary, cage damage, and vandalism.)
- 7.10. Supplemental Feeding.** Permittee shall complete supplemental feeding, as follows, for each "soft" release session (i.e., at the initial release following the exclusion fence installation and trapping). Seed shall be broadcast at the release sites 3 evenings per week for the first month following the removal of the retention cages and one evening each week thereafter for the next 3 months and biweekly for the remainder of the year. If subsequent years are drought years, supplemental feeding may need to reinitiate during the winter months. This shall be discussed with CDFW. Seed will be microwaved for 1-3 minutes before broadcast at the release site to prevent seed germination and alteration of the native vegetation community.
- 7.11. Relocation Monitoring.** Following the removal of the retention cages, the Designated Biologist(s) shall conduct live small mammal trapping in the relocation release area(s). Permittee shall conduct relocation monitoring per the methodology approved in the Covered Species Relocation Plan (Condition of Approval 7.7). For relocation areas that are not fenced, individuals shall be monitored via "backpack" transmitters. In areas that are fenced, other monitoring methods may be appropriate as approved by CDFW. A report of the relocation monitoring findings shall be submitted to CDFW within 14 days of each trapping effort and summarized annually.
- 7.12. Exclusionary Fence Maintenance.** Exclusionary fencing that remains within the Project Areas shall be inspected by the Designated Biologist(s) at the close of each workday, or as otherwise approved by CDFW in writing, to ensure that it is in place and properly maintained for the duration of Covered Activities.
- 7.13. Covered Species Monitoring.** Designated Biologist(s) shall perform daily visual surveys, or as otherwise approved by CDFW in writing, for kangaroo rat burrows, signs, and individuals prior to the start of Covered Activities within the Project Area and a 100-foot buffer, including stockpiles and equipment storage areas. Positive new findings shall be mapped and submitted to CDFW within 24 hours. If Covered Activities are occurring within 100 feet of a kangaroo rat burrow, the Designated Biologist(s) shall monitor the burrow for disturbance (e.g. debris or water accumulation) a minimum of 3 times daily. If the burrow shows evidence of disturbance, the Designated Biologist(s) shall immediately make adjustments to the location, type, and/or frequency of the Covered Activities occurring to preclude further potential impacts and increase monitoring of the burrow to ensure the

adjustments were effective. The Designated Biologist(s) shall use best professional judgement regarding the monitoring period and adjustment of the work buffer surrounding the burrow. If impacts beyond those authorized in this ITP are identified or suspected, Permittee shall cease the Project Activities potentially responsible for those impacts and notify CDFW immediately. Results of monitoring, including photographs and a brief assessment, the type of activity occurring (e.g. drilling, grading, falsework, etc.), distance from the burrow, impacts measured/noted, and any buffer adjustment made shall be provided to CDFW within 24 hours.

7.14. Lighting Minimization. If feasible, the Project Activities will be restricted to daytime hours. If nighttime construction is needed, Permittee shall implement the following measures within 500 feet of Covered Species habitat:

7.14.1. The Designated Biologist(s) shall be present at all times;

7.14.2. Vehicles and equipment shall not exceed 5 miles per hour;

7.14.3. All construction-related lighting shall not have significant illumination pass beyond the immediate work area. Shielding techniques may include, but should not be limited to, the use of fence slats, netting, mesh, or tarps; and

7.14.4. All construction lighting shall be yellow or orange lighting, and below 0.1 lux (units of illuminations).

7.15. Covered Species Injury. If a Covered Species is injured as a result of Project-related activities, the Designated Biologist shall immediately take it to a CDFW approved wildlife rehabilitation or veterinary facility. Permittee shall identify the facility before starting Covered Activities. Permittee shall bear any costs associated with the care or treatment of such injured Covered Species. The Permittee shall notify CDFW of the injury to the Covered Species immediately by telephone and e-mail followed by a written incident report as described in Condition of Approval 6.8. Notification shall include the name of the facility where the animal was taken.

8. Habitat Management Land Acquisition: CDFW has determined that permanent protection and perpetual management of compensatory habitat is necessary and required pursuant to CESA to fully mitigate Project-related impacts of the taking on the Covered Species that will result from implementation of the Covered Activities. This determination is based on factors including an assessment of the importance of the habitat in the Project Area, the extent to which the Covered Activities will impact the habitat, and CDFW's estimate of the protected acreage required to provide for adequate compensation.

To meet this requirement, the Permittee shall provide for both the permanent protection and management of 145 acres of Habitat Management (HM) lands pursuant to Condition of Approval

8.3 below and the calculation and deposit of the management funds pursuant to Condition of Approval 8.4 below. Permittee shall ensure that the proposed HM lands supports all Covered Species in this agreement. Permanent protection and funding for perpetual management of HM lands must be complete before starting Covered Activities, or within 18 months of the effective date of this ITP if Security is provided pursuant to Condition of Approval 9 below for all uncompleted obligations. The Permittee shall also permanently protect and manage the CDFW-approved relocation receiver site pursuant to Condition of Approval 8.5.

8.1. Cost Estimates. For the purposes of determining the Security amount, CDFW has estimated the cost sufficient for CDFW or its contractors to complete acquisition, protection, and perpetual management of the HM lands as follows:

- 8.1.1. Land acquisition costs for HM lands identified in Condition of Approval 8.2 below, estimated at \$150,000/acre for 145 acres: **\$21,750,000.00**. Land acquisitions costs are estimated using local fair market current value per acre for lands with habitat values meeting mitigation requirements;
- 8.1.2. All other costs necessary to review and acquire the land in fee title and record a conservation easement as described in Condition of Approval 8.2.1 and 8.2.2 below: **\$17,440.00**;
- 8.1.3. Start-up costs for HM lands, including initial site protection and enhancement costs as described in Condition of Approval 8.2.6 below, estimated at **\$615,660.00**;
- 8.1.4. Interim management period funding as described in Condition of Approval 8.2.7 below, estimated at **\$1,095,242.00**;
- 8.1.5. Long-term management funding as described in Condition of Approval 8.3 below, estimated at \$36,468.00/acre for 145 acres: **\$5,287,903.00**. Long-term management funding is estimated initially for the purpose of providing Security to ensure implementation of HM lands management.
- 8.1.6. Related transaction fees including but not limited to account set-up fees, administrative fees, title and documentation review and related title transactions, expenses incurred from other state agency reviews, and overhead related to transfer of HM lands to CDFW as described in Condition of Approval 8.4, estimated at **\$8,800.00**.
- 8.1.7. All costs associated with CDFW engaging an outside contractor to complete the mitigation tasks, including but not limited to acquisition, protection, and perpetual funding and management of the HM lands and restoration of temporarily disturbed habitat. These costs include but are not limited to the cost of issuing a request for

proposals, transaction costs, contract administration costs, and costs associated with monitoring the contractor's work **\$75,000.00**.

8.2. Habitat Management Lands Acquisition and Protection. If the Permittee elects to provide for the acquisition, permanent protection, and perpetual management of HM lands to complete compensatory mitigation obligations, then the Permittee shall:

- 8.2.1. Fee Title. Transfer fee title of the HM lands to CDFW pursuant to terms approved in writing by CDFW. Alternatively, CDFW, in its sole discretion, may authorize a governmental entity, special district, non-profit organization, for-profit entity, person, or another entity to hold title to and manage the property provided that the district, organization, entity, or person meets the requirements of Government Code sections 65965-65968, as amended.
- 8.2.2. Conservation Easement. If CDFW does not hold fee title to the HM lands, CDFW shall act as grantee for a conservation easement over the HM lands or shall, in its sole discretion, approve a non-profit entity, public agency, or Native American tribe to act as grantee for a conservation easement over the HM lands provided that the entity, agency, or tribe meets the requirements of Civil Code section 815.3. If CDFW elects not to be named as the grantee for the conservation easement, CDFW shall be expressly named in the conservation easement as a third-party beneficiary. The Permittee shall obtain CDFW written approval of any conservation easement before its execution or recordation. No conservation easement shall be approved by CDFW unless it complies with Civil Code sections 815-816, as amended, and Government Code sections 65965-65968, as amended and includes provisions expressly addressing Government Code sections 65966(j) and 65967(e). Because the "doctrine of merger" could invalidate the conservation interest, under no circumstances can the fee title owner of the HM lands serve as grantee for the conservation easement.
- 8.2.3. HM Lands Approval. Obtain CDFW written approval of the HM lands before acquisition and/or transfer of the land by submitting, at least three months before acquisition and/or transfer of the HM lands, documentation identifying the land to be purchased or property interest conveyed to an approved entity as mitigation for the Project's impacts on Covered Species;
- 8.2.4. HM Lands Documentation. Provide a recent preliminary title report, Phase I Environmental Site Assessment, and other necessary documents (please contact CDFW for document list). All documents conveying the HM lands and all conditions of title are subject to the approval of CDFW, and if applicable, the Wildlife Conservation Board and the Department of General Services;

- 8.2.5. Land Manager. Designate both an interim and long-term land manager approved by CDFW. The interim and long-term land managers may, but need not, be the same. The interim and/or long-term land managers may be the landowner or another party. Documents related to land management shall identify both the interim and long-term land managers. Permittee shall notify CDFW of any subsequent changes in the land manager within 30 days of the change. If CDFW will hold fee title to the mitigation land, CDFW will also act as both the interim and long-term land manager unless otherwise specified. The grantee for the conservation easement cannot serve as the interim or long-term manager without the express written authorization of CDFW in its sole discretion.
- 8.2.6. Start-up Activities. Provide for the implementation of start-up activities, including the initial site protection and enhancement of HM lands, once the HM lands have been approved by CDFW. Start-up activities include, at a minimum: (1) preparing a final management plan for CDFW approval (see optional management plan template at <https://nrm.dfg.ca.gov/FileHandler.ashx?DocumentID=227736>) (2) conducting a baseline biological assessment and land survey report within four months of recording or transfer; (3) developing and transferring Geographic Information Systems (GIS) data if applicable; (4) establishing initial fencing in needed areas; (5) conducting litter and dumped material removal; (6) baseline Covered Species surveys (7) conducting initial habitat restoration or enhancement including any plant collection from the project site, native plantings, invasive removal, restoration of fluvial processes and any technique that may benefit the long-term survival of the Covered Species, if applicable; (8) Remedies for violations; and (9) installing signage. Please include any personnel and equipment needed in the final management plan;
- 8.2.7. Interim Management (Initial and Capital). Provide for the interim management of the HM lands. The Permittee shall ensure that the interim land manager implements the interim management of the HM lands as described in the final management plan and conservation easement approved by CDFW. The interim management plan must be submitted to CDFW for review and approval within 45 days of biological approval of the future Conservation Easement. The interim management period shall be a minimum of three years from the date of HM land acquisition and protection and full funding of the Endowment and includes expected management following start-up activities. Interim management period activities described in the final management plan shall include fence repair, continuing trash removal, site monitoring, yearly Covered Species surveys, any Covered Species specific management/monitoring/adaptive management, and vegetation and invasive species management. An annual report shall be submitted to CDFW on the first of each year and must include any shapefiles or KMZs of trap lines and positive and negative occurrences of Covered Species.

Permittee shall either (1) establish an escrow account with written instructions approved in advance in writing by CDFW to pay the land manager annually in advance, or (2) establish a short-term enhancement account with CDFW or a CDFW-approved entity for payment to the land manager.

- 8.3. Endowment Fund.** If the Permittee elects to provide for the acquisition, permanent protection, and perpetual management of HM lands to complete compensatory mitigation obligations, then the Permittee shall ensure that the HM lands are perpetually managed, maintained, and monitored by the long-term land manager as described in this ITP, the conservation easement, and the final management plan approved by CDFW. After obtaining CDFW approval of the HM lands, Permittee shall provide long-term management funding for the perpetual management of the HM lands by establishing a long-term management fund (Endowment). The Endowment is a sum of money, held in a CDFW-approved fund that is permanently restricted to paying the costs of long-term management and stewardship of the mitigation property for which the funds were set aside, which costs include the perpetual management, maintenance, monitoring, and other activities on the HM lands consistent with this ITP, the conservation easement, and the management plan required by Conditions of Approval 8.2.6 and 8.2.7. Endowment as used in this ITP shall refer to the endowment deposit and all interest, dividends, other earnings, additions and appreciation thereon. The Endowment shall be governed by this ITP, Government Code sections 65965-65968, as amended, and Probate Code sections 18501-18510, as amended.

After the interim management period, Permittee shall ensure that the designated long-term land manager implements the management and monitoring of the HM lands according to the final management plan. The long-term land manager shall be obligated to manage and monitor the HM lands in perpetuity to preserve their conservation values in accordance with this ITP, the conservation easement, and the final management plan. Such activities shall be funded through the Endowment.

- 8.3.1. Identify an Endowment Manager.** The Endowment shall be held by the Endowment Manager, which shall be either CDFW or another entity qualified pursuant to Government Code sections 65965-65968, as amended.

Permittee shall submit to CDFW a written proposal that includes: (i) the name of the proposed Endowment Manager; (ii) whether the proposed Endowment Manager is a governmental entity, special district, nonprofit organization, community foundation, or congressionally chartered foundation; (iii) whether the proposed Endowment Manager holds the property or an interest in the property for conservation purposes as required by Government Code section 65968(b)(1) or, in the alternative, the basis for finding that the Project qualifies for an exception pursuant to Government Code section 65968(b)(2); and (iv) a copy of the proposed Endowment Manager's certification pursuant to Government Code section 65968(e).

Within thirty days of CDFW's receipt of Permittee's written proposal, CDFW shall inform Permittee in writing if it determines the proposal does not satisfy the requirements of Fish and Game Code section 2081(b)(3) and, if so, shall provide Permittee with a written explanation of the reasons for its determination. If CDFW does not provide Permittee with a written determination within the thirty-day period, the proposal shall be deemed consistent with Section 2081(b)(3).

8.3.2. Calculate the Endowment Funds Deposit. After obtaining CDFW written approval of the HM lands, long-term management plan, and Endowment Manager, Permittee shall prepare an endowment assessment (equivalent to a Property Analysis Record (PAR)) to calculate the amount of funding necessary to ensure the long-term management of the HM lands (Endowment Deposit Amount). Note that the endowment for the easement holder should not be included in this calculation. The Permittee shall submit to CDFW for review and approval the results of the endowment assessment before transferring funds to the Endowment Manager.

8.3.2.1. Capitalization Rate and Fees. Permittee shall obtain the capitalization rate from the selected Endowment Manager for use in calculating the endowment assessment and adjust for any additional administrative, periodic, or annual fees.

8.3.2.2. Endowment Buffers/Assumptions. Permittee shall include in the endowment assessment assumptions the following buffers for endowment establishment and use that will substantially ensure long-term viability and security of the Endowment:

8.3.2.2.1. 10 Percent Contingency. A 10 percent contingency shall be added to each endowment calculation to hedge against underestimation of the fund, unanticipated expenditures, inflation, or catastrophic events.

8.3.2.2.2. Three Years Delayed Spending. The endowment shall be established assuming spending will not occur for the first three years after full funding.

8.3.2.2.3. Non-annualized Expenses. For all large capital expenses to occur periodically but not annually such as fence replacement or well replacement, payments shall be withheld from the annual disbursement until the year of anticipated need or upon request to Endowment Manager and CDFW.

8.3.3. Transfer Long-term Endowment Funds. Permittee shall transfer the long-term endowment funds to the Endowment Manager upon CDFW approval of the Endowment Deposit Amount identified above.

8.3.4. Management of the Endowment. The approved Endowment Manager may pool the Endowment with other endowments for the operation, management, and protection of HM lands for local populations of the Covered Species but shall maintain separate accounting for each Endowment. The Endowment Manager shall, at all times, hold and manage the Endowment in compliance with this ITP, Government Code sections 65965-65968, as amended, and Probate Code sections 18501-18510, as amended.

Notwithstanding Probate Code sections 18501-18510, the Endowment Manager shall not make any disbursement from the Endowment that will result in expenditure of any portion of the principal of the endowment without the prior written approval of CDFW in its sole discretion. Permittee shall ensure that this requirement is included in any agreement of any kind governing the holding, investment, management, and/or disbursement of the Endowment funds.

Notwithstanding Probate Code sections 18501-18510, if CDFW determines in its sole discretion that an expenditure needs to be made from the Endowment to preserve the conservation values of the HM lands, the Endowment Manager shall process that expenditure in accordance with directions from CDFW. The Endowment Manager shall not be liable for any shortfall in the Endowment resulting from CDFW's decision to make such an expenditure.

- 8.4. Reimburse CDFW. Permittee shall reimburse CDFW for all reasonable costs incurred by CDFW related to issuance and monitoring of this ITP, including, but not limited to transaction fees, account set-up fees, administrative fees, title and documentation review and related title transactions, costs incurred from other state agency reviews, and overhead related to transfer of HM lands to CDFW.
- 8.5. Habitat Enhancement and Monitoring. Prior to the initiation of Covered Activities and for the term of the ITP, Permittee shall enhance the 46.7-acre proposed relocation receiver site (i.e., Plunge Creek area). Enhancement activities may include, but not be limited to: collection of plants/native vegetation/soil from project site to use in the receiver site or proposed HM Lands, removal of vegetation, including dead trees and/or shrubs, fallen trees, and nonnative vegetation; removal of trash and debris; placement of gravel or other substrate within stream channels; mimicry of riparian processes such as flood disturbances, movement of large woody debris, sediment transport and scouring, redirecting flow in the streambed to stimulate new meanders, and diversification of vegetation densities into patches and mosaics; installation of fencing for Covered Species retainment; installation of artificial burrows; and installation signage to protect and conserve the enhancement area. Monitoring of the Covered Species must follow the CDFW approved Relocation Plan (Condition of Approval 7.7) and must include a post-relocation monitoring plan. This plan must include, at a minimum, Covered Species trapping and surveys and methods to anchor the Covered Species to the relocation site. Permittee shall submit a report and photos to

CDFW documenting the completion of enhancement activities within 60 days of completion. Permittee shall also implement ways to control invasive species and reduce shrub cover as well as monitor for Covered Species as outlined in Condition of Approval 7.7.

- 9. Security:** The Permittee may proceed with Covered Activities only after the Permittee has ensured funding (Security) to complete any activity required by Condition of Approval 8 that has not been completed before Covered Activities begin. Permittee shall provide Security as follows:
- 9.1. Security Amount.** The Security shall be in the amount of **\$28,775,045.00** or in the amount identified in 8.1 specific to the obligation that has not been completed. This amount is determined by CDFW based on the cost estimates identified in Condition of Approval 8.1 above, sufficient for CDFW or its contractors to complete land acquisition, property enhancement, startup costs, initial management, long-term management, and monitoring.
- 9.2. Security Form.** The Security shall be in the form of an irrevocable letter of credit (see Attachment 3) or another form of Security approved in advance in writing by CDFW's Office of the General Counsel.
- 9.3. Security Timeline.** The Security shall be provided to CDFW before Covered Activities begin or within 30 days after the effective date of this ITP, whichever occurs first.
- 9.4. Security Holder.** The Security shall be held by CDFW or in a manner approved in advance in writing by CDFW.
- 9.5. Security Transmittal.** Permittee shall transmit security to CDFW by way of an approved instrument such as an escrow agreement, irrevocable letter of credit, or other.
- 9.6. Security Drawing.** The Security shall allow CDFW to draw on the principal sum if CDFW, in its sole discretion, determines that the Permittee has failed to comply with the Conditions of Approval of this ITP.
- 9.7. Security Release.** The Security (or any portion of the Security then remaining) shall be released to the Permittee after CDFW has conducted an on-site inspection and received confirmation that all secured requirements have been satisfied, as evidenced by:
- Written documentation of the acquisition of the HM lands;
 - Copies of all executed and recorded conservation easements;
 - Written confirmation from the approved Endowment Manager of its receipt of the full Endowment; and
 - Timely submission of all required reports.

Even if Security is provided, the Permittee must complete the required acquisition, protection and transfer of all HM lands and record any required conservation easements no later than 18 months

from the effective date of this ITP. CDFW may require the Permittee to provide additional HM lands and/or additional funding to ensure the impacts of the taking are minimized and fully mitigated, as required by law, if the Permittee does not complete these requirements within the specified timeframe.

IX. Amendment:

This ITP may be amended as provided by California Code of Regulations, Title 14, section 783.6, subdivision (c), and other applicable law. This ITP may be amended without the concurrence of the Permittee as required by law, including if CDFW determines that continued implementation of the Project as authorized under this ITP would jeopardize the continued existence of the Covered Species or where Project changes or changed biological conditions necessitate an ITP amendment to ensure that all Project-related impacts of the taking to the Covered Species are minimized and fully mitigated.

X. Stop-Work Order:

If CDFW determines the Permittee has violated any term or condition of this ITP or has engaged in unlawful take, CDFW may issue Permittee a written stop-work order instructing the Permittee to suspend any Covered Activity for an initial period of up to 30 days or risk suspension or revocation of this ITP. CDFW can issue a stop-work order to prevent or remedy a violation of this ITP, including but not limited to the failure to comply with reporting or monitoring obligations, or to prevent the unauthorized take of any CESA endangered, threatened, or candidate species, regardless of whether that species is a Covered Species under this ITP. Permittee shall stop work immediately as directed by CDFW upon receipt of any such stop-work order. Upon written notice to Permittee, CDFW may extend any stop-work order issued to Permittee for a period not to exceed 30 additional days.

If Permittee fails to remedy the violation or to comply with a stop-work order, CDFW may proceed with suspension and revocation of this ITP. Suspension and revocation of this ITP shall be governed by California Code of Regulations, Title 14, section 783.7, and any other applicable law. Neither the Designated Biologist nor CDFW shall be liable for any costs incurred in complying with stop-work orders.

XI. Compliance with Other Laws:

This ITP sets forth CDFW's requirements for the Permittee to implement the Project pursuant to CESA. This ITP does not necessarily create an entitlement to proceed with the Project. Permittee is responsible for complying with all other applicable federal, state, and local law.

XII. Notices:

Written notices, reports and other communications relating to this ITP shall be delivered to CDFW by email or registered first class mail at the following address, or at addresses CDFW may subsequently provide the Permittee. Notices, reports, and other communications shall reference the Project name, Permittee, and ITP Number (2081-2025-037-06) in a cover letter and on any other associated

documents.

Original cover with attachment(s) to:

Heidi Calvert, Regional Manager
California Department of Fish and Wildlife
3602 Inland Empire Boulevard, Suite C-220
Ontario, CA 91764
(909) 484-0523
R6CESA@wildlife.ca.gov

and a copy to:

Habitat Conservation Planning Branch
California Department of Fish and Wildlife
Attention: CESA Permitting Program
Post Office Box 944209
Sacramento, CA 94244-2090
CESA@wildlife.ca.gov

Unless Permittee is notified otherwise, CDFW's Regional Representative for purposes of addressing issues that arise during implementation of this ITP is:

Chelsea Price
Inland Deserts Region
3602 Inland Empire Boulevard, Suite C-220
Ontario, CA 91764
Chelsea.Price@wildlife.ca.gov

XIII. Compliance with the California Environmental Quality Act:

CDFW's issuance of this ITP is subject to CEQA. CDFW is a responsible agency pursuant to CEQA with respect to this ITP because of prior environmental review of the Project by the lead agency, San Bernardino Valley Water Conservation District. (See generally Pub. Resources Code, §§ 21067, 21069.) The lead agency's prior environmental review of the Project is set forth in the Upper Santa Ana River Wash Land Management and Habitat Conservation Plan, (SCH No.: 2004051023) dated March 24, 2008 that the San Bernardino Valley Water Conservation District certified on July 19, 2012. At the time the lead agency certified the EIR and approved the Project it also adopted various mitigation measures for the Covered Species as conditions of Project approval.

This ITP, along with CDFW's related CEQA findings, which are available as a separate document, provide evidence of CDFW's consideration of the lead agency's EIR for the Project and the environmental effects related to issuance of this ITP (CEQA Guidelines, § 15096, subd. (f)). CDFW finds that issuance of this ITP will not result in any previously undisclosed potentially significant

Incidental Take Permit
No. 2081-2025-037-06
CEMEX CONSTRUCTION MATERIALS PACIFIC, LLC
CEMEX PROJECT PHASE 1

effects on the environment or a substantial increase in the severity of any potentially significant environmental effects previously disclosed by the lead agency. Furthermore, to the extent the potential for such effects exists, CDFW finds adherence to and implementation of the Conditions of Project Approval adopted by the lead agency, and that adherence to and implementation of the Conditions of Approval imposed by CDFW through the issuance of this ITP, will avoid or reduce to below a level of significance any such potential effects. CDFW consequently finds that issuance of this ITP will not result in any significant, adverse impacts on the environment.

XIV. Findings Pursuant to CESA:

These findings are intended to document CDFW's compliance with the specific findings requirements set forth in CESA and related regulations. (Fish & G. Code § 2081, subs. (b)-(c); Cal. Code Regs., tit. 14, §§ 783.4, subds, (a)-(b), 783.5, subd. (c)(2).)

CDFW finds based on substantial evidence in the ITP application, Santa Ana River Water Rights Applications for Supplemental Water Supply and Upper Santa Ana River Wash Land Management and Habitat Conservation Plan, the results of consultations, and the administrative record of proceedings, that issuance of this ITP complies and is consistent with the criteria governing the issuance of ITPs pursuant to CESA:

- (1) Take of Covered Species as defined in this ITP will be incidental to the otherwise lawful activities covered under this ITP;
- (2) Impacts of the taking on Covered Species will be minimized and fully mitigated through the implementation of measures required by this ITP and as described in the MMRP. Measures include: (1) permanent habitat protection; (2) establishment of avoidance zones; (3) worker education; and (4) Compliance Reports. CDFW evaluated factors including an assessment of the importance of the habitat in the Project Area, the extent to which the Covered Activities will impact the habitat, and CDFW's estimate of the acreage required to provide for adequate compensation. Based on this evaluation, CDFW determined that the protection and management in perpetuity of 145 acres of compensatory habitat that is contiguous with other protected Covered Species habitat and/or is of higher quality than the habitat being destroyed by the Project, along with the minimization, monitoring, reporting, and funding requirements of this ITP minimizes and fully mitigates the impacts of the taking caused by the Project;
- (3) The take avoidance and mitigation measures required pursuant to the conditions of this ITP and its attachments are roughly proportional in extent to the impacts of the taking authorized by this ITP;
- (4) The measures required by this ITP maintain Permittee's objectives to the greatest extent possible;
- (5) All required measures are capable of successful implementation;

- (6) This ITP is consistent with any regulations adopted pursuant to Fish and Game Code sections 2112 and 2114;
- (7) Permittee has ensured adequate funding to implement the measures required by this ITP as well as for monitoring compliance with, and the effectiveness of, those measures for the Project; and
- (8) Issuance of this ITP will not jeopardize the continued existence of the Covered Species based on the best scientific and other information reasonably available, and this finding includes consideration of the species' capability to survive and reproduce, and any adverse impacts of the taking on those abilities in light of (1) known population trends; (2) known threats to the species; and (3) reasonably foreseeable impacts on the species from other related projects and activities. Moreover, CDFW's finding is based, in part, on CDFW's express authority to amend the terms and conditions of this ITP without concurrence of the Permittee as necessary to avoid jeopardy and as required by law.

XV. Attachments:

FIGURE 1	Map of Project
FIGURE 2	SBKR Retention Cage
ATTACHMENT 1	Mitigation Monitoring and Reporting Program
ATTACHMENT 2	Biologist Resume Form
ATTACHMENT 3	Letter of Credit Form

ISSUED BY THE CALIFORNIA DEPARTMENT OF FISH AND WILDLIFE ON 12/29/2025

DocuSigned by:

CAEE4779B63E4A3...
Heidi Calvert, Regional Manager
Inland Deserts Region

Incidental Take Permit
No. 2081-2025-037-06
CEMEX CONSTRUCTION MATERIALS PACIFIC, LLC
CEMEX PROJECT PHASE 1

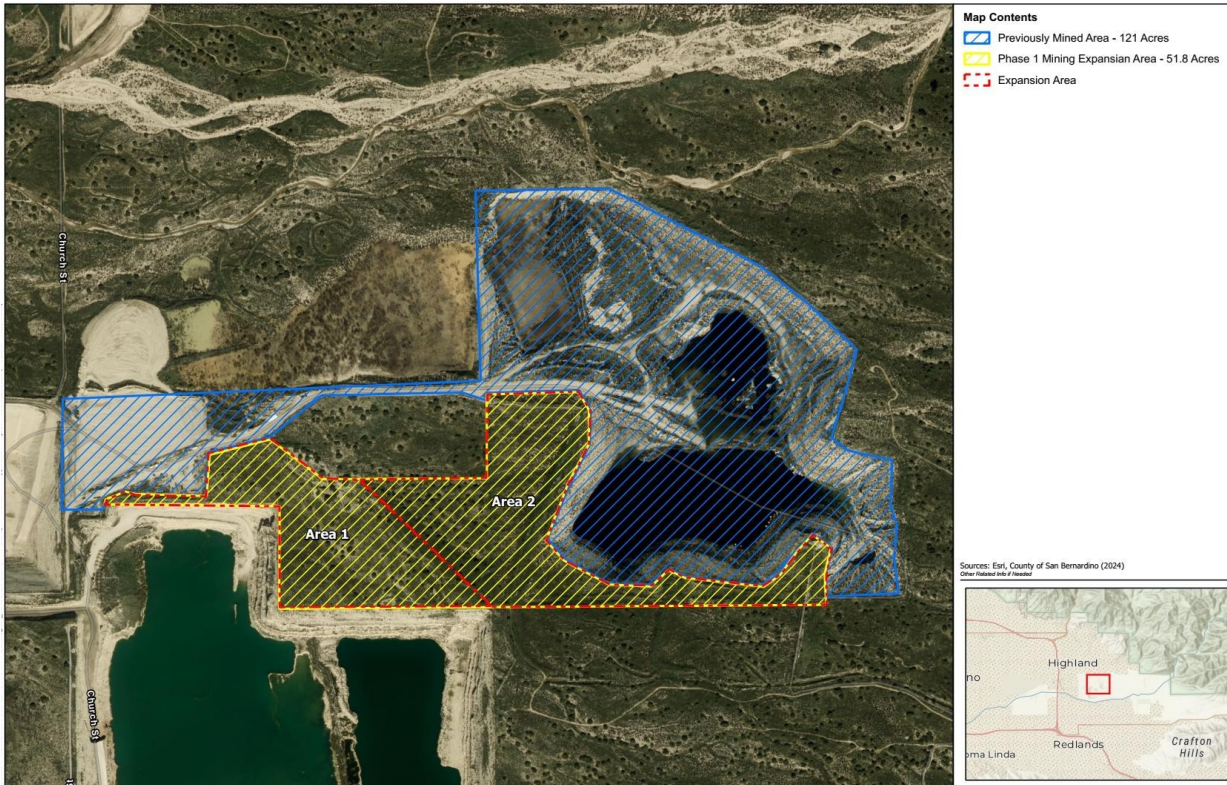

Figure 1. Project footprint consisting of new mining (yellow hash - 51.8 acres) and existing mining (blue hash - 121 acres) and location of project in Redlands, CA. Figure Provided by ECORP.

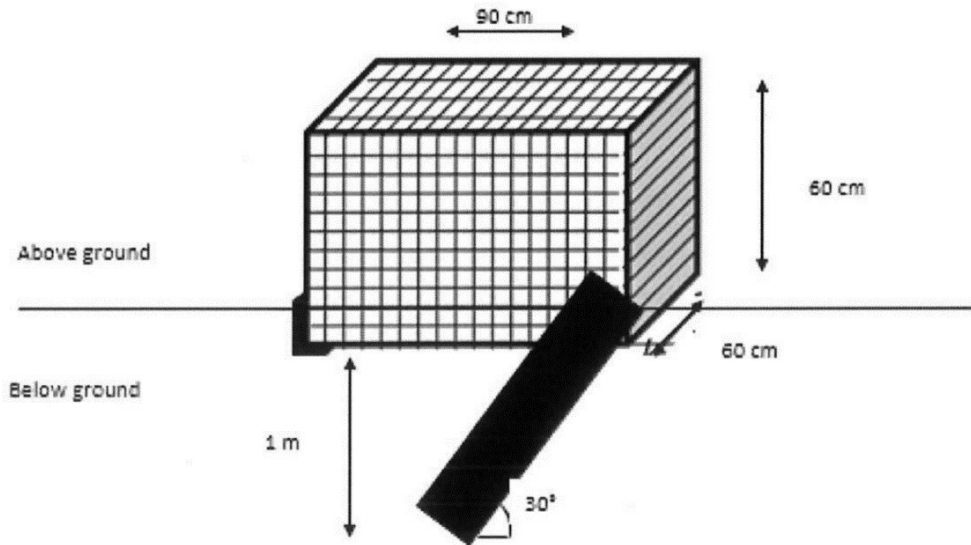

Figure 2. SBKR retention cage (Condition of Approval 7.9.1).