

Aquatic Invasive Species Monitoring at CDFW Hatcheries

California Department of Fish and Wildlife

June 2025

Invasive Species

“Invasive species” are defined as plants or animals that cause environmental or economic harm, or harm to human health. Invasive species tend to be adaptable to new environments and multiply quickly. It is difficult to predict where an invasion will occur, which species may invade, or the consequences of their invasion. Therefore, to protect facilities and the environment it is necessary to monitor invasive species so that if an invasion does occur, efforts can be made quickly to prevent their spread within an area and to adjacent areas. Invasive species threaten the diversity and abundance of native and desirable non- native species through competition for resources, predation, parasitism, hybridization, transmission of diseases, and/or causing physical or chemical changes to the environment. Invasive species also threaten man-made systems and structures, including water delivery and flood protection systems, agriculture, and developed lands.

Invasive species are commonly introduced into new areas by human activities. Natural barriers such as mountains or oceans historically confined species to their native range. Commerce and the advent of travel between remote locations has circumvented natural barriers; and trains, planes, ships, and vehicles are capable of transporting organism’s great distances, often unknowingly and unintentionally. Hatchery activities have the potential to spread invasive species to new waterbodies, as well as between waterbodies, when stocking fish. Invasive species in hatcheries pose several concerns. First, they may become established within a hatchery and impact operations, including clogging pipes, aeration devices, screens, and encrusting equipment, necessitating added maintenance. Second, they may be spread to other hatcheries and/or into the environment along with transferred or planted fish. Alternatively, invasive species may not directly impact operations at a hatchery, and thus go unnoticed, or pass through a hatchery in its source water. Both situations present the opportunity for hatchery activities to move invasive species to new environments in transport water and therefore must also be addressed.

This protocol is limited to monitoring for aquatic invasive species (AIS); however, it is recommended that precautions to prevent the spread of terrestrial invasive species also be taken. This protocol does not address fish health issues or disease prevention.

Monitoring for AIS is a component of a comprehensive Hazard Analysis-Critical Control Point (HACCP) Plan, which identifies pathways and preventatives for the introduction of AIS into a hatchery, the spread of AIS within a hatchery, and the release of AIS from a hatchery.

Sources of Aquatic Invasive Species

Many hatcheries use surface water for operation. Surface waters are susceptible to AIS contamination, particularly if accessible for recreation (boating, fishing, etc.). Most of CDFW's anadromous mitigation hatcheries are located below dams and use water directly from an impounded reservoir that allows recreational access. Other hatcheries are located further downriver from reservoirs, or on rivers where recreation occurs, and are also at risk of AIS contamination. Well water pumped directly into a hatchery is at very low risk of being contaminated with AIS.

Other potential pathways for the introduction of AIS into a hatchery include the importation of eggs or fish, or by picking up an AIS on equipment or vehicles while planting fish. These pathways, and all others, should be addressed in a comprehensive HACCP Plan.

Aquatic Invasive Species of Concern, and Aids to Their Identification

AIS believed to pose the greatest threat to California's hatcheries and the environment are Golden Mussel, Quagga Mussel, Zebra Mussel, and New Zealand Mudsail, and the monitoring methods described herein are specific for these four species. Other AIS of concern, including Channeled Apple Snail, Brazilian Waterweed, Eurasian Watermilfoil, Hydrilla, and the alga *Didymosphenia geminata* (also known as Didymo or rock snot), are described in Attachment A and should be reported if found. Refer to Attachment A for species descriptions, suitable environmental conditions, known range, and photos to assist in their identification.

QUAGGA MUSSEL AND ZEBRA MUSSEL

Dreissena bugensis* and *Dreissena polymorpha

Quagga and Zebra mussels are separate species but look very similar. The following description applies to both species. These freshwater mussels produce microscopic, free-floating larvae. The larvae eventually settle on surfaces and turn into the shelled adult form.

Species Description:

Body form – Juveniles and adults are 2-shelled (bivalve); may have dark colored “threads” on one edge. Larval life-stage is microscopic and cannot be seen by the unaided eye.

Size – Range in size from microscopic to up to 2” long; free-floating (planktonic) larvae are microscopic.

Color – Shells usually have alternating light and dark brown stripes but can also be solid light brown to dark brown.

Suitable Environmental Conditions:

Temperature – Survives in water temperatures between 32°F and 88°F.

Moisture – Aquatic but can survive out of water for weeks under suitable conditions

(longest at low temperatures and high humidity).

Substrate – Usually attached to soft and hard surfaces, including aquatic plants, but may detach from surfaces and be carried by water. Small, newly settled mussels feel like gritty sandpaper when attached to a smooth surface. Larger mussels may feel coarser, like a small pebble or sunflower seed. Mussels typically adhere to surfaces firmly and when lightly touched may rock back and forth.

Known occurrences in California – Imperial, Los Angeles, Orange, Riverside, San Benito, San Bernardino, San Diego, and Ventura counties. The CDFW Quagga/Zebra Mussel Program maintains a map of [locations of Quagga and Zebra mussels in California](#).

Key Features for Identification:

Invasive Golden, Quagga and Zebra Mussels are not the only freshwater bivalve found in California; however, they are the only freshwater bivalves that attach to surfaces. In the absence of attachment, a combination of characteristics including their alternating bands of color and evidence of “threads” can be used to identify. However, invasive mussel species require an expert for accurate identification. Suspect invasive mussel specimens should be forwarded to the [Regional Scientist](#) for further identification.



Quagga Mussel, showing size and color variation in mussels.

GOLDEN MUSSEL
Limnoperna fortunei

The first North American detection of golden mussel (*Limnoperna fortunei*) was in October 2024. Although this mussel is similar in appearance and impacts to quagga and zebra mussels, it can establish in waters with a greater variety of conditions, including waters with lower calcium levels and wider temperature and salinity ranges.

Species Description:

Body form – Juveniles and adults are 2-shelled (bivalve); may have dark colored “threads” on one edge. Larval life-stage is microscopic and cannot be seen by the unaided eye.

Size – Range in size from microscopic to up to 2” long; free-floating (planktonic) larvae are microscopic.

Color – Shell color is light golden to darker yellowish-brown to brown color.

Suitable Environmental Conditions:

Temperature – Survives in water temperatures between 41–95 °F.

Moisture – Aquatic but can survive out of water for weeks under suitable conditions (longest at low temperatures and high humidity).

Substrate –Usually attached to soft and hard surfaces, including aquatic plants, but may detach from surfaces and be carried by water. Small, newly settled mussels feel like gritty sandpaper when attached to a smooth surface. Larger mussels may feel coarser, like a small pebble or sunflower seed. Mussels typically adhere to surfaces firmly and when lightly touched may rock back and forth.

Known occurrences in California - The CDFW Invasive Species Program maintains a [map of locations of Golden Mussel in California](#).

Key Features for Identification:

Golden mussels are similar in appearance to other invasive mussel species and require an expert for accurate identification. Suspect invasive mussel specimens should be forwarded to the [Regional Scientist](#) for further identification.



Golden Mussel coloring and a colony.

NEW ZEALAND MUDSNAIL
Potamopyrgus antipodarum

Small, fresh to brackish water snail that can be easily overlooked because it often blends in with its surroundings. New Zealand Mudsnaails are self-reproducing and give birth to live offspring. Therefore, a single snail can create a population.

Species Description:

Body form – Single shell that is elongated and spiraled, when fully grown having 5-7 spirals.

Size – From microscopic up to ¼” long.

Color – Variable; light to dark brown in color.

Suitable Environmental Conditions:

Temperature – Survives in waters between 32°F and 83°F.

Moisture – Aquatic but can survive out of water for weeks under suitable temperatures and humidity.

Substrate – Soft (mud, silt, plants, etc.) and hard substrates. Also capable of detaching and floating in the water.

Known occurrences in California – The U.S. Geological Survey NAS – Nonindigenous Aquatic Species database provides information on [current known locations](#).

Key Features for Identification:

A key feature of live New Zealand Mudsnaails is the presence of an operculum (flap covering the shell opening). New Zealand Mudsnaails requires an expert for accurate identification. Suspect snail specimens should be forwarded to the [Regional Scientist](#) for further identification.



Dead New Zealand mudsnail on metric ruler (5 millimeters = ~¼”). Operculum often absent in dead specimens.



Live New Zealand mudsnail showing operculum and spirals, numbered 1-5.



Dense colony of New Zealand mudsnails attached to the underside of a rock.

Monitoring for Golden, Quagga and Zebra Mussels and New Zealand Mudsnail

General Guidelines

Early detection monitoring concentrates efforts on areas where AIS are most likely to be found, rather than by random sampling. Attention should be directed to protected areas, such as crevasses, corners, and edges.

Hatchery personnel should always be on the lookout for unfamiliar plants and animals during daily operations. Current maintenance-intensive hatchery operations provide considerable opportunities to watch for AIS. Intensive maintenance could, however, inhibit the detection of AIS. Routine cleaning may prevent organisms from attaching to surfaces, becoming established, growing large enough to detect, or keeping them at such low densities that they remain undetected.

In addition to watching for AIS during routine operations, hatcheries should inspect their facilities at least monthly for AIS. Inspections provide only a snapshot in time, and do not guarantee that a facility is AIS-free. Increasing the frequency of inspections and using a variety of methods will improve the likelihood that an AIS is detected. In addition, monitoring can be useful in identifying the point of AIS introduction, should an infestation occur.

Because each AIS is different, no one method is effective for detecting all species. A combination of methods, including specialized sampling devices and examination of existing surfaces, is necessary. Monitoring methods and specific directions, as well as procedures for documenting and reporting monitoring, are provided below.

Monitoring Source Water and Outflow

A means for continuous monitoring of non-well water entering the hatchery is necessary. Detecting AIS in water coming into a hatchery can exclude hatchery activities as the source of an AIS infestation. A portion of the inflow is routed into a flow-through system, referred to as a “biobox”, designed to provide a suitable environment for some AIS species, making their detection possible. In addition, hatchery staff should examine debris, including plants, entrained on intake screens and trash racks for AIS. If it is not feasible to use a biobox at the inflow, then artificial substrates should be deployed near the water intake.

Because hatchery water is released into the environment untreated, AIS may be released as well. Hatchery outflow monitoring screens all the water passing through the hatchery and is the final opportunity to detect AIS. Outflow monitoring can be achieved using either a biobox, artificial substrates, and surface survey for depths three feet and greater, or surface survey for depths less than three feet.

Bioboxes

- **This method is suitable for detection of Golden Mussels, Quagga Mussels, Zebra Mussels, and New Zealand Mudsnails.**

Bioboxes are flow-through systems designed specifically to sample for the larval/settlement stage of Golden Mussel, Quagga Mussels, Zebra Mussels and New Zealand Mudsnails. Microscopic larvae are suspended in the water, and upon reaching settlement stage, attach to surfaces. The biobox provides suitable conditions (surface and flow) for this to occur. Flow rates greater than 5 feet/sec inhibit mussel and mudsnail settlement, so a flow-through system must not exceed this velocity.

Location(s):

If using bioboxes, one will be installed where raw water enters the facility and, if feasible, at each (if more than one) hatchery outflow, prior to discharge. Bioboxes are not needed on water drawn directly from a well. Bioboxes should be placed on a stable surface adequate to support its weight. If the water temperature inside the biobox is more than 2°F above the hatchery water temperature, then the biobox must be shaded. Bioboxes should be in areas that will not be damaged by water if the box were to overflow. Individual hatcheries may need to modify the Biobox during installment to adequately meet all flow and temperature requirements. Infrastructure modifications may be needed to connect the Biobox to an intake or outflow system.

Monitoring Frequency:

Bioboxes should be checked regularly to ensure they are operating correctly and maintaining the appropriate flow rate. A visual and tactile (touch) examination is conducted monthly.

Requirements for Biobox Design:

- Minimum internal volume of 12 gallons
- Flow rate of 1.32 gallons/minute

The following design specifications meet the biobox requirements above.

Biobox Construction and Assembly (Figure 1):

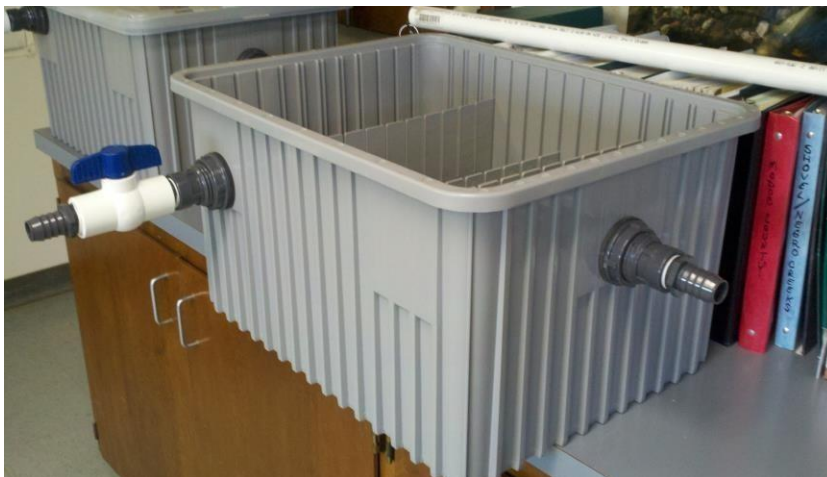

Figure 1. Basic biobox consisting of a grey bin with an inflow valve, an outlet spigot, and removable divider plates. (Designed by Jody Rightmier, CDFW Yreka Screen Shop).

BIOBOX MATERIALS AND PARTS LIST:

Material/Part	Quantity*
1" PVC Ball Valve Female threaded ends, quarter turn design	1
Nipple TBE SCH 80 1" x close PVC	1
1" PVC 90-degree elbow slip x slip SCH 40	1
1" pipe x MIPT PVC insert male adapter	2
1' PVC Tank adapter SOCXFPT NPRN gasket	2
1' x 2" (length) SCH 40 PVC pipe	1
22 x 17 x 12" grey storage bin with dividers	1
Snap F/DC3000 storage bin cover	1
Short Divider F/DC3080 (sold in 6 pk)	3
ER308L 3/32 x 36" TIG welding rod	1
1/2 " bolt size medium flat washer 18-8 stainless/steel	6

* Quantity of materials and parts required to construct a single biobox.

The plates slide down into “grooves on either side of the interior walls of the box (Figure 2) and water flows over and under the plates as it passes through the box.

Plates are kept submerged with stainless steel wire and washers that allow for removal when inspecting the plates. Flow into the box is regulated by a valve on the incoming water line. The outlet is an overflow pipe that ensures the water level in the box remains at a constant level. All interior surfaces and plates are roughed up with fine (150-180 grit) sandpaper to maximize suitability for settlement.



Figure 2. Interior view of biobox plates that provide suitable surfaces for mussel and mudsnail settlement.

Monitoring Procedure:

To inspect a biobox, begin by closing the inflow valve. One at a time, carefully remove each plate. Do not set the plates down as small or delicate organisms could be crushed. Hold the plate over a separate container to catch any dislodged organisms and visually inspect it. Use a magnifying glass if necessary. Next, gently run fingers over the plates to feel for any organisms. Very small Golden, Quagga or Zebra mussels may be more easily felt than seen. Do not leave the plates out of the water so long that they dry; examine and return to the water immediately if no suspect organisms are found.

When finished with the first plate, reinsert it and inspect the remaining plates the same way. Also examine the inner walls of the biobox. If the walls are transparent, look in from the outside. If not, view from above. Next, gently run fingers over the walls as with the plates. When finished, open the valve to resume appropriate flow.

Artificial Substrates

- **This method is suitable for detection of Golden, Quagga and Zebra mussels.**

If it is not feasible to use a biobox at the inflow or outflow, then artificial substrates should be deployed.

ARTIFICIAL SUBSTRATE MATERIALS AND PARTS LIST:

Material/Part	Quantity*
6" x 6" x 0.25" black/grey PVC with 1" hole through center	4
1.5" x 1.375" (35mm) exterior diameter PVC or ABS tube	5
8.5" x 0.8125" (21 mm) exterior diameter PVC or ABS tube	1
~25 ft plastic coated cable or rope	1
Some form of attachment to keep plates from floating up	1
Weight	1
Laminated label with your contact information	1

* *Quantity of materials and parts required to construct a single artificial substrate.*

To assemble the substrate, run the cable or rope through the 8.5" tube and secure at one end. From the loose end of the rope string on the remaining pieces, alternating between the short segments of tube and the plates, beginning, and ending with the short tubes (see figure). Secure the top tube to the rope to prevent the pieces from floating up. If necessary, attach a weight to the bottom of the assembly. Attach the label to the cable where the cable is secured to the structure.

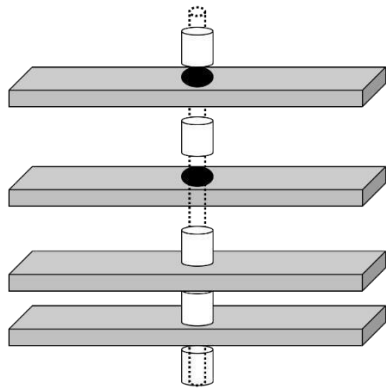

California Department of Fish and Wildlife
Biological Research

PLEASE DO NOT DISTURB



Deployment of the Artificial Substrates:

Depending on water clarity and depth, the artificial substrate should be set below the euphotic zone (below the depth of light penetration) or 6 feet, whichever is deeper, and at least two feet above the bottom. One to two substrates are deployed per site. If the site is shallower than 2 m, then raise the substrate about 0.5 m (2 ft) off the bottom. Record the actual sampling depth. At sites that are deep and have little vertical mixing, a second substrate is installed at a depth of approximately 15 meters (50 feet) below the surface (or 1 meter off the bottom if the depth is less than 15 meters).

Monitoring Procedure:

To check an artificial substrate, first carefully lift it out of the water and place it in a large plastic tub (the tub will capture any mussels that fall off). Avoid knocking the substrate as you pull it out of the water because you may dislodge or crush any attached mussels. First visually inspect each plate (top, bottom, and sides), the spacers, the cable, and the weight. Use a magnifying glass if necessary. Next, gently run fingers over the plates to feel for any organisms. Very small quagga or zebra mussels may be more easily felt than seen. After looking closely, attempt to gently push any attached organism that might be a mussel. Freshwater limpets and snails easily move or slide across the plate. Golden, Zebra and Quagga mussels stick in place or are more securely attached. In all cases, if in doubt, bag it.

If no mussels are detected, lower the substrate back into the water. Golden, Zebra and Quagga mussels are more likely to attach to a substrate that has some algal growth, however if the substrate becomes too heavily coated it may be unsuitable for mussel settlement. As necessary, gently remove heavy accumulations of algae to maintain suitable conditions for settlement.

Monitoring In-Hatchery and Outflow

In addition to monitoring the inflow and outflows, surface surveys should be conducted within the hatchery facilities (including the outflows if a biobox is not used)

Surface Surveys

- **This method is suitable for detection of Golden, Quagga and Zebra mussels and New Zealand mudsnail.**

When areas are dewatered during hatchery operations, any emerging surfaces should be immediately inspected for AIS. Many AIS blend in with their surroundings and prefer sheltered areas, so close inspection is necessary and most easily conducted when dewatered. In addition, all submerged surfaces and structures within the hatchery should be inspected at least monthly. Specific instructions on how to inspect surfaces is provided below.

Locations and Frequency:

Inspect 5% of dewatered surfaces as dewatering occurs. In addition, inspect 5% of submerged surfaces throughout the facility each month. For example, if there are ten raceways, inspect the safely accessible surfaces equivalent to one-half of a raceway (10 raceways x 0.05 = 0.5 raceways), divided among the ten raceways. Spreading the 5% over all the raceways increases the chance of finding an AIS if it is in the facility.

The 5% applies to surfaces, outflow settling ponds (if applicable) as well as equipment such as screens, tubing, lines, etc. As with all forms of early detection monitoring, the more you look, the more likely you are to find something if it is there. Aim to err on exceeding the minimum sampling requirement, rather than just meeting it.

If monitoring is conducted outside of secured areas of the hatchery there is greater potential that they are infested with invasive species. Do not allow gear that will be returned to the hatchery (including, but not limited to boots, waders, nets, etc.) to contact the settling ponds. In these cases, gear dedicated to this purpose should be used, prominently labeled, and stored separately from other gear. If dedicated gear is not feasible, then gear must be decontaminated after monitoring outside of the hatchery according to the [CDFW Aquatic Invasive Species Decontamination Protocol](#).

Monitoring Procedure:

Carefully examine surfaces both visually and tactilely by running fingers over them, with particular attention given to protected areas such as crevasses, corners, and edges, and areas where fish are excluded from. If needed, use a magnifying glass, flashlight, or other aides to thoroughly examine.

Specimen Identification and Collection

If a suspect AIS is detected either during daily operations or monitoring, immediately contact your [CDFW Regional AIS Scientist](#). To aid their identification, first take a close-up digital photograph of the organism next to a ruler so that there is a size reference. Next, collect the specimen(s) and place in a container where it will not be crushed and add enough 70% ethanol to cover it. Label the sample with hatchery name, location within the hatchery, date,

suspected species, and the name of who collected it. If the entire substrate needs to be retained, place the entire unit in a plastic bag. Email the photos to the CDFW Regional AIS Scientist and they will try to identify the specimens from the photographs. If they are unable to identify the species from photographs, they may request the specimen(s) or substrate.

Data Recording and Reporting

Monthly monitoring is to be conducted in the last week of each month. Monthly AIS Monitoring Datasheets must be filled out to document monitoring and are to be submitted by the end of each month. Absence data is as important to document as presence, so complete and submit a datasheet even if no AIS is found. Hatcheries are to send an electronic copy of the datasheet to their respective regional Senior Hatchery Supervisor, Regional AIS Scientist, to the Fisheries Branch Fish Production Program Manager, Headquarters AIS Program (invasives@wildlife.ca.gov), and Statewide Hatchery Coordinator via email, and retain the originals on-site. All data will be entered into a centralized monitoring database maintained by the Invasive Species Program

AIS Hatchery Data Sheet Located in the Document Library at:

<https://nrm.dfg.ca.gov/FileHandler.ashx?DocumentID=223668>

Summary of Monitoring Methods and Minimum Monitoring Frequency

AIS Monitoring will be conducted the last week of the Month.	Biobox and Artificial Substrates	Surface Survey
Inflow	Monthly	N/A
In Hatchery	N/A	5% when Dewatered Monthly Inspect 5% of Raceway surfaces Monthly
Outflow	Monthly	5% Monthly

The following additional AIS of concern is known to commonly occur in California and should also be reported if found. This list is not exhaustive and additional species of concern may be encountered and reported.

Animals

- Channeled apple snail

Plants and Algae

- Eurasian watermilfoil
- Brazilian waterweed or Brazilian elodea
- Hydrilla
- Rock snot or Didymo

Pomacea canaliculata

Freshwater aquatic snail. Channeled apple snails leave the water to lay eggs and eat terrestrial vegetation. Eggs hatch and juvenile snails return to the water. Reproduction is dependent on food availability and water temperature, but usually occurs in the early spring and early fall.

Species Description:

Body form – Single shell with compact spirals that are deeply indented, hence the common name “channeled”. Eggs are reddish in color and loosely attached to each other in masses of 200-600.

Size – Adult shells can reach up to 3” long, individual eggs are 0.09-0.14” in diameter.

Color – Shell color is yellowish to brown.

Suitable Environmental Conditions:

Temperature – Survives in water between 65°F and 90°F.

Moisture – Aquatic, but commonly leaves water to lay eggs and eat. Can survive out of water for several months by closing the opening of its shell and bedding in the soil.

Substrate – Soft (mud, silt, plants, etc.) and hard surfaces.

Known occurrences in California – Lake Miramar, San Diego County, Norton Simon Museum Pond, Los Angeles County, and Riverside County near the Salton Sea.

Key Features for Identification:

The large size of adult channeled apple snails and their egg masses are unique. Smaller specimens may be identifiable by their round, deeply indented shell.



Adult channeled apple snail shells.

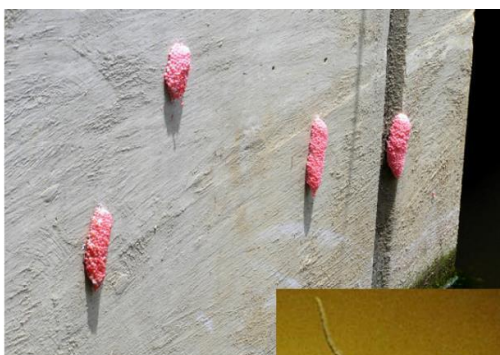

Egg masses.



Newly hatched (5 day) channeled apple snail.

EURASIAN WATERMILFOIL

Myriophyllum spicatum

Species Description:

Plant – Reddish-brown or whitish-pink.

Stems – Branched and 20-30" long, reddish-brown or whitish-pink.

Leaves – Olive green and occasionally reddish tinted and arranged circularly around the stem in groups of 3-6 (usually 4). Each leaf is less than 2" long, soft, and feather-like. Each leaf has a rib and 14-24 or so slender segments on each side of the rib.

Flowers – Individual flowers are reddish, very small, and many together form spikes several inches long that are held above the water.

Roots – Fibrous, often developed on small pieces broken off larger plants.

Suitable Environmental Conditions:

Temperature – Able to overwinter in frozen lakes and ponds in northern states and Canada; also, able to grow in shallow, overheated bays.

Moisture – submerged; often found in water 1½" to 12' deep, and up to 30' deep in very clear water. Prefers lakes, ponds, slow-moving rivers and streams, but can also grow in fast-moving water. Tolerates a wide range of water conditions, including spring water and even brackish water of tidal creeks and bays with salinity of up to 10 parts per thousand.

Substrate – Roots in all types of substrates, and broken pieces float freely.

Known occurrences in California – Sacramento-San Joaquin Delta, San Francisco Bay Area and Central Valley ditches and lakes; margins of Southern California's south-east border.

Key Features for Identification:

Finely divided, feather-like leaves ½ to 2" long.



Color variation of Eurasian watermilfoil



illustration provided by:
IFAS, Center for Aquatic Plants
University of Florida, Gainesville, 1990



Node: Each point where a leaf (or leaves) attaches to the stem.

Leaves less than 2" long, feathery and number 3-6, usually 4 (as shown here) around the stem. Each leaf has 14-24 leaflets per side of main rib.

Whorl: Circular arrangement of leaves (when viewed from above) around the stem.

BRAZILIAN WATERWEED OR BRAZILIAN ELODEA
***Egeria densa* Species**

Description:

Plant – Green.

Stems – Highly branched and can reach 25' or more in length.

Leaf attachment to stem (nodes) – Densely spaced at growing tip and indistinguishable. Points of attachment are more widely spaced near the main stem and stems deeper in the water. Double nodes bear branches and flowers.

Leaves – Thin, $\frac{3}{4}$ – $1\frac{1}{2}$ " in length and $\frac{1}{16}$ – $\frac{1}{8}$ " wide, arranged circularly around the stems when viewed from above (whorls) of 3-6 leaves. Spear-shaped leaves have tiny teeth that may require a magnifying glass to see. The number of leaves doubles or triples (up to 12 leaves per whorl) every 8-12 whorls.

Flowers – Three white petals and are about $\frac{3}{4}$ " across on 1" stems above the surface of the water.

Roots – Thin.

Suitable Environmental Conditions:

Temperature – Survives in water between 40°F and 90°F.

Moisture – Underwater, in both flowing and shallow and standing water.

Substrate – Roots in all types of substrates; broken pieces float freely.

Known occurrences in California – Throughout the Sacramento-San Joaquin Delta.

Key Features for Identification:

Robust 1-inch leaves closely spaced in whorls of 3-6 around the stem. Also refer to page 21 for a comparison with similar species.

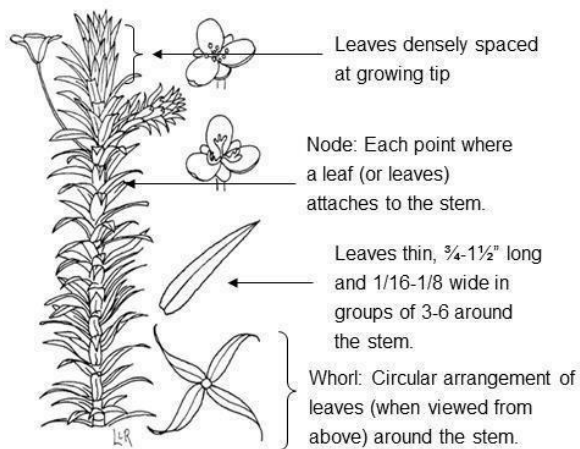

HYDRILLA

Hydrilla verticillata

Species Description:

Plant – Green, up to 25' long.

Stems – Slender, branched.

Leaves – Spear-shaped, ½ - ¾" long and 1/16" wide arranged in groups of 4-8 leaves around the stem. Leaf margins distinctly saw-toothed. Often 1-2 sharp teeth along the underside of the leaf rib.

Flowers – Tiny, white flowers born on long stalks at the surface of the water.

Roots – Roots are white and may have yellowish, potato-like structures ½" long and ½" wide at the tips of the roots.

Suitable Environmental Conditions:

Temperature – Somewhat winter-hardy; its optimum water temperature is 68 °F -81 °F; its maximum temperature is 86 °F.

Moisture – Underwater, from a few inches deep to more than 20'.

Substrate – May be found in all types of water bodies including springs, lakes, ponds, marshes, ditches, canals, rivers, tidal zones. Broken pieces float freely.

Known occurrences in California – As of 2024, hydrilla has been observed in the Mojave and Colorado deserts, south and central coasts, San Francisco Bay Area, and Central Valley. Isolated infestations of are found in Shasta, Yuba, Lake, Calaveras, Madera, Mariposa, and Imperial counties.

Key Features for Identification:

Hydrilla has distinctly saw-toothed leaf edges and teeth on the leaf underside. In addition, potato-like tubers on roots are diagnostic. Also refer to page 22 for a comparison with similar species.

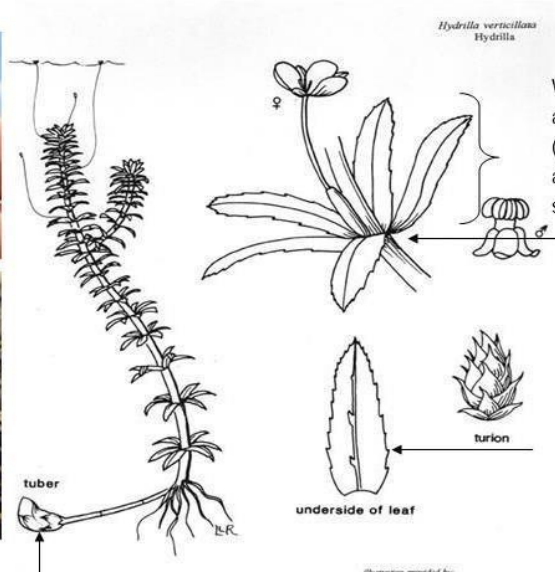

Whorl: Circular arrangement of 4-8 leaves (when viewed from above) around the stem (5 leaves shown here).

Node: Each point where a leaf (or leaves) attaches to the stem.

Spear-shaped leaf, 1/2 - 3/4" long and 1/16" wide. Edges saw-toothed and underside of rib with 1-2 teeth (2 shown here).

Potato-like tuber

Side-by-side comparison of two invasive aquatic plants, *Egeria densa* and *Hydrilla verticillata*, to the common native *Elodea canadensis*.

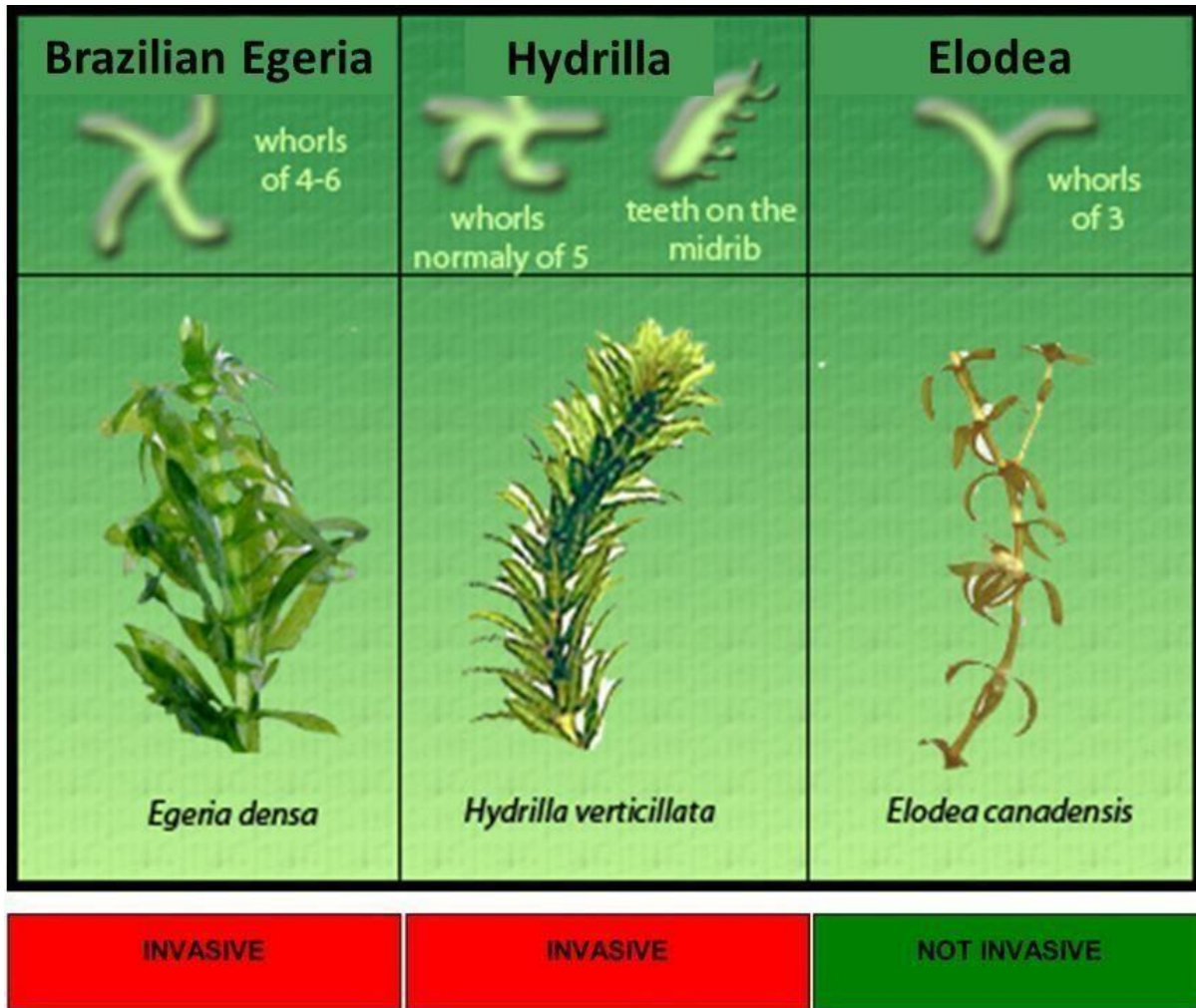

ROCK SNOT OR DIDYMO
Didymosphenia geminata

Species Description:

Growth form – Single-celled algae that form thick mats.

Size – Starts as small clumps and can spread to entirely cover wetted areas.

Color – Pale yellowish-brown to white.

Suitable Environmental Conditions:

Temperature – 32° - 72°F

Moisture – Submerged.

Substrate – Attaches to hard and soft substrates at depths of 4” to 6½ ‘. Fragments float freely.

Known occurrences in California – South Fork of the American River, Sierra Nevada.



Rock out of water, colonized with rock snot.

Key Features for Identification:

Looks like slimy blobs attached to rocks or wet toilet paper trailing from rocks and aquatic plants in streams, and as mats in slow moving water. Appears slimy but feels coarse, like damp wool.



Rock snot structure, as seen under a microscope.



Rock snot in flowing water.